

FSNF120 US

On/Off, Spring Return, 350°F [177°C] for half hour, 120VAC, 15 Seconds Cycle Time



| Technical Data | |
|-------------------------------------|---|
| Power Supply | 120 VAC, ±10%, 50/60 Hz |
| Power consumption in operation | 27 VA |
| Power consumption in rest position | 6 W, 9 VA (50 Hz 15 VA), End stop 55 VA, 0.5 A slow blow fuse * |
| Shaft Diameter | 1/2" to 1.05" round, centers on 1/2" and 3/4" with insert, 1.05" without insert |
| Electrical Connection | 18 GA, 3 ft [1 m], 3 color coded wires |
| Overload Protection | electronic throughout 0° to 95° rotation |
| Electrical Protection | grounded enclosure, 120V |
| Angle of rotation | 95° |
| Torque motor | 70 in-lb [8 Nm] from 32...350°F [0...177°C] |
| direction of rotation motor | reversible with CW/CCW mounting |
| direction of rotation spring-return | reversible with cw/ccw mounting |
| Position indication | visual indicator, 0° to 95° (0° is full spring return position) |
| Running Time (Motor) | 15 sec between 32...350°F [0...177°C], <15 sec at rated voltage & torque |
| Running Time (Fail-Safe) | 15 sec |
| Ambient humidity | 5...95% r.H. non-condensing |
| Ambient temperature | 32...122°F [0...50°C] |
| Non-operating temperature | -40...176°F [-40...80°C] |
| Degree of Protection | IP40, NEMA 1 |
| Housing material | zinc coated steel |
| Gears | steel, permanently lubricated |
| Agency Listing | cULus listed to UL873 and CAN/CSA C22.2 No.24, UL 2043 Listed for air plenum installation per NEC 300.22 and IMC Section 602 NYC Department of Buildings MEA 197-07-M.California State Fire Marshal Listing 3210-1593:101. |
| Noise level, motor | 45 dB (A) motor, 62 dB (A) spring, inaudible holding |
| Maintenance | maintenance free |
| Quality Standard | ISO 9001 |
| Weight | 6.58 lb [3.0 kg] |

† UL File XAPX.E108966

Fire & Smoke damper actuator

Application

The type FSNF spring-return actuator is intended for the operation of smoke and combination fire and smoke dampers in ventilation and air-conditioning systems. The actuator will meet requirements of UL555 and UL555S when tested as an assembly with the damper and will meet requirements of UBC for 15 second opening and closing at 350°F. Square footage of damper operated will depend on make and model and the temperature required.

IMPORTANT 24VDC NOTE: The FSNF24 & -S models will not operate below 24VDC. A filtered and regulated power supply must be used.

Operation

Mounting of the actuator to the damper axle shaft or jackshaft (3/8" to 1.05") is via a cold-weld clamp. Teeth in the clamp and V-bolt dig into the metal of both solid and hollow shafts maintaining a perfect connection. The specially designed clamp will not crush hollow shafts. The bottom end of the actuator is held by an anti-rotation strap or by a stud provided by the damper manufacturer.

The actuator is mounted in its fail safe position with the damper blade(s) closed. Upon applying power, the actuator drives the damper to the open position. The internal spring is tensioned at the same time. If the power supply is interrupted, the spring moves the damper back to its fail-safe position.

Dimensions (Inches[mm])

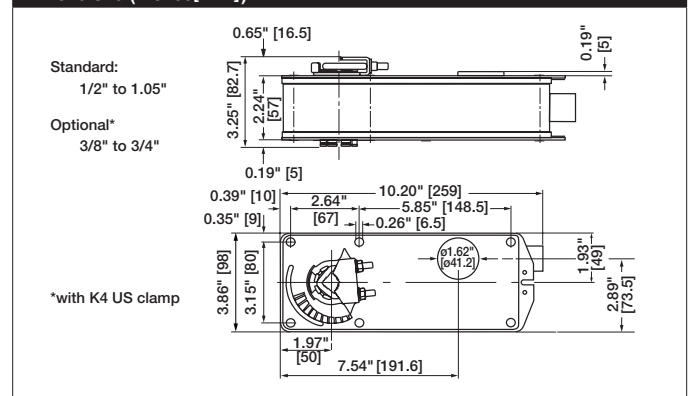

Safety Notes

* Neither UL nor Belimo require local over-current protection. The FSNF actuators draw higher peak current when driving against any type of stop. If used, this requires the value of a local fuse or breaker to be increased to avoid nuisance opening or tripping. A 2.5 amp slow blow should be used for 24VAC. A 0.5 amp slow blow should be used for 120 VAC. A 0.25 amp slow blow should be used for 230V and a 0.3 amp slow blow for 208 VAC. Transformers: Note that while a 24V 100VA transformer would handle 2 actuators, a 4 A breaker or plug fuse is insufficient. A 5 amp slow blow would be required. Belimo Fire & Smoke actuators have passed the AMCA 520 and UL 555S Long Term Holding test. No special cycling is required during prolonged periods when actuator is driven open and held there. Periodic testing of dampers and actuators per local codes and NFPA 80 and NFPA 105 are required.

The actuator contains no components which the user can replace or repair. A 1/2" threaded connector is standard. FSNFxx-FC models have a 3/8" Flex Connector. Other than the connector, these actuators are identical to the conduit connector version.

⚠ WARNING: For Belimo Products sold in California, these Products do or may contain chemicals which are known to the State of California to cause cancer and or birth defects or other reproductive harms. For more information see www.p65warnings.ca.gov.

Accessories

| | |
|------------|--|
| AF-P | Anti-rotation bracket AF/NF. |
| IND-AF2 | End stop indicator |
| K4-1 US | Classic AF/NF jackshaft clamp (up to 1.05"). |
| KH-AF-1 US | Classic AF/NF crankarm for Jackshaft to 1.05". |
| SH8 | Push rod for KG6 & KG8 ball joints (36" L, 5/16" diameter). |
| ZDB-AF2 US | Angle of rotation limiter for Classic AF/NF. |
| ZG-100 | Univ. right angle bracket 17"x11-1/8"x6" (HxWxbase). |
| ZG-101 | Univ. right angle bracket 13x11x7-7/16" (HxWxbase). |
| ZG-AF US | Classic AF/NF crankarm adaptor kit. |
| ZG-AF108 | Classic AF/NF crankarm adaptor kit with ZG-108. |
| ZG-DC1 | Damper clip for damper blade, 3.5" width. |
| ZG-DC2 | Damper clip for damper blade, 6" width. |
| ZS-100 | Weather shield - galvaneal 13x8x6" (LxWxD). |
| ZS-150 | Weather shield - PC w/ foam seal 16x8-3/8x4" (LxWxD). |
| ZS-260 | Explosion proof housing. |
| ZS-300 | NEMA 4X, 304 stainless steel enclosure. |
| BAE165 US | 165° F electric thermal sensor, SPST, normally closed. |
| S2A-F US | Auxiliary switch, 2x SPDT, 3A (0.5A inductive) @250 VAC max. |

Typical Specification

All smoke and combination fire and smoke dampers shall be provided with Belimo FSTF, FSLF, FSNF, or FSAF actuators. All substitutions must be approved before submission of bid. Damper and actuator shall have UL 555S Listing for 250°F (350°F). Actuator shall have been tested to UL 2043 per requirements of IMC 602.2 and NEC 300.22 (c). Where position indication is required -S models with auxiliary switches or damper blade switches will be provided per code requirements.

Wiring Diagrams
INSTALLATION NOTES

- Provide overload protection and disconnect as required.
- Actuators may be powered in parallel. Power consumption must be observed.
- Ground present on some models.

