

# FSTF120 US

## On/Off, Spring Return Fail-Safe, 120 VAC



Technical Data	
Power Supply	120 VAC, ±10%, 50/60 Hz
Power consumption in operation	2 W, 3.5 VA
Power consumption in rest position	1.5 W, 2.5 VA
Shaft Diameter	1/4" to 1/2" round, centers on 1/2"
Electrical Connection	3 ft [1 m], 18 GA appliance cable with 1/2" conduit connector
Overload Protection	electronic throughout 0° to 95° rotation
Electrical Protection	actuators are double insulated
Angle of rotation	95°
Torque motor	18 in-lb [2 Nm]
direction of rotation motor	reversible with CW/CCW mounting
direction of rotation spring-return	reversible with CW/CCW mounting
Position indication	visual indicator, 0° to 95° (0° is full spring return position)
Running time motor	<75 sec @ 250°F [121°C]
Running time emergency control position	<25 sec @ 32...122°F [0...50°C]
Ambient humidity	5 to 95% RH non-condensing
Ambient temperature	32...122°F [0...50°C]
Non-operating temperature	-40...176°F [-40...80°C]
Degree of Protection	IP42, NEMA 2, UL Enclosure Type 2
Housing material	UL94-5VA
Agency Listing	cULus acc. to UL60730-1A/-2-14, CAN/CSA E60730-1:02, Listed to UL 2043 - suitable for use in air plenums per Section 300.22(C) of the NEC and Section 602 of the IMC. California State Fire Marshal Listing 3210-1593:104
Noise level, motor	<45 dB (A)
Noise Level (Fail-Safe)	<62 dB (A)
Maintenance	maintenance free
Quality Standard	ISO 9001
Weight	1.59 lb [0.60 kg]

Part no.	Clamp side spring return
FSTF120 US	CW
FSTF120.1 US	CW (bulk pack)
FSTF120.1 CCW	CCW (bulk pack)
FSTF120-S US CW	CW
FSTF120-S.1 US	CW (bulk pack)
FSTF120-S.1 CCW	CCW (bulk pack)
FSTF24-S.1 US	CW (bulk pack)

† UL File XAPX.E108966

**Torque 18 in-lb, 250°F for 30 min, for fire and smoke dampers**

### Application

The type FSTF spring-return actuator is intended for the operation of smoke and combination fire and smoke dampers in ventilation and air-conditioning systems. The actuator will meet requirements of UL555 and UL555S when tested as an assembly with the damper. Square footage of damper operated will depend on make and model per damper manufacturer UL testing.

### Operation

Mounting of the actuator to the damper axle shaft or jackshaft is via a cold-weld clamp. Teeth in the clamp and V-bolt dig into the metal of both solid and hollow shafts maintaining a perfect connection. The specially designed clamp will not crush hollow shafts. The bottom end of the actuator is held by an anti-rotation strap or by a stud provided by the damper manufacturer. The actuator is mounted in its fail safe position with the damper blade(s) typically closed. Upon applying power, the actuator drives the damper to the open position. The internal spring is tensioned at the same time. If the power supply is interrupted, the spring moves the damper back to its fail-safe position.

### Dimensions (Inches[mm])

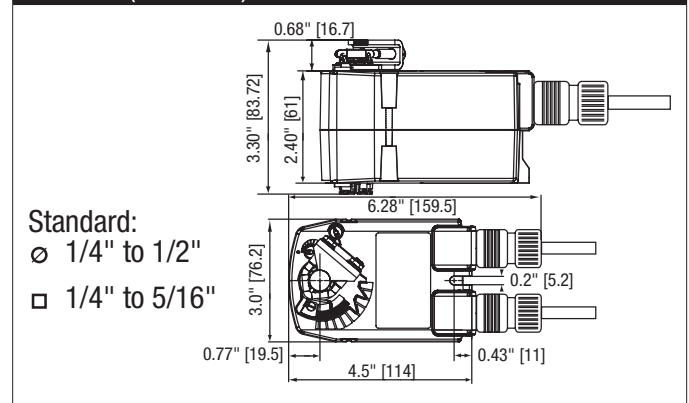

### Safety Notes

Screw a conduit fitting into the actuator's bushing. Jacket the actuator's input and output wiring with suitable flexible conduit. Properly terminate the conduit in a suitable junction box.

#### Retrofit Safety Note

Use of the FSTF for replacement of other makes of actuators is limited in damper area. The FSLF is preferred for direct coupled applications. The FSTF may be applied for linkage applications on dampers 1.5 sq.ft. and smaller at velocities under 2000 fpm.

Accessories	
---KH-TF US	TFB(X) crankarm with 5/16" slot.
---KH-TF-1 US	TFB(X) crankarm with 1/4" slot.
KH-TF-1.1 US	TFB(X) crankarm for Shafts with 1/4" slot.
---TF-P	Anti-rotation bracket TF/NKQ/AM/NM/LM.
---TOOL-06	8 mm and 10 mm wrench.
---ZG-TF2	TFB(X) crankarm adaptor kit (T bracket included).
---ZG-TF112	TFB(X) crankarm adaptor kit (includes ZG-113).
---ZS-100	Weather shield - galvaneal (13" L x 8" W x 6" D).
---ZS-150	Weather shield - PC w/ foam seal (16" L x 8-3/8" W x 4" D).
---BAE165 US	165° F electric thermal sensor, SPST, normally closed.

### Typical Specification

All smoke and combination fire and smoke dampers shall be provided with Belimo FSTF, FSLF, FSNF, or FSAF actuators. All substitutions must be approved before submission of bid. Damper and actuator shall have UL 555S Listing for 250°F &/or 350°F. Actuator shall have been tested to UL 2043 per requirements of IMC 602.2 and NEC 300.22 (c). Where position indication is required -S models with auxiliary switches or damper blade switches will be provided per code requirements.

### Wiring Diagrams

- Provide overload protection and disconnect as required.
- Actuators may be powered in parallel. Power consumption must be observed.
- Ground present on some models.
- Meets cULus requirements without the need of an electrical ground connection.

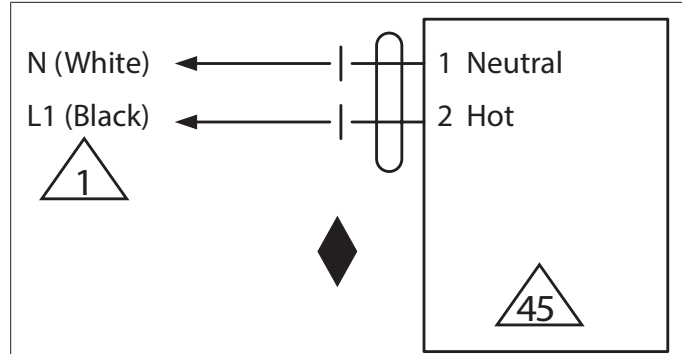

120 VAC

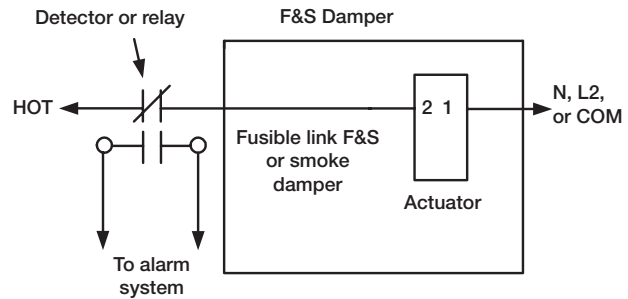

Typical smoke or fusible link damper wiring

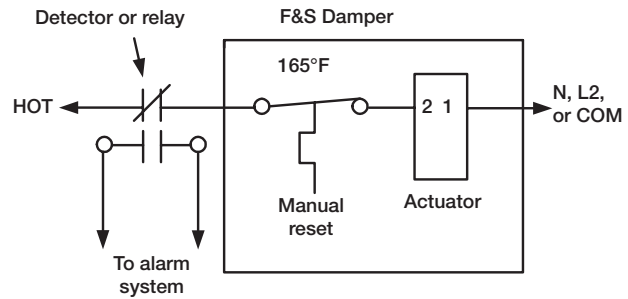

Typical containment damper control wiring

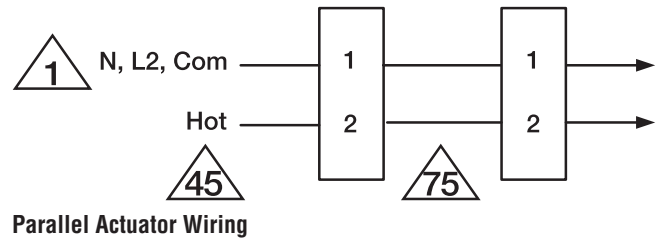

Parallel Actuator Wiring