

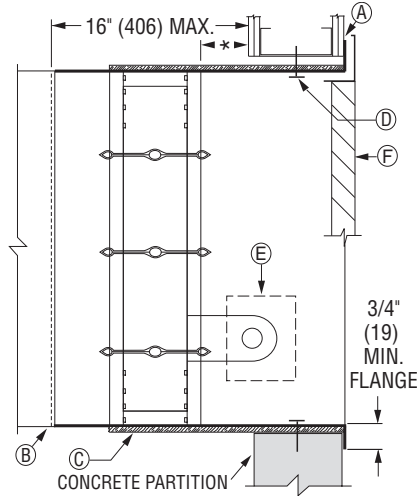

**ITEMS:**

- A** Typical 2 hour rated vertical concrete or steel stud construction and horizontal concrete fire partition
- B** Duct connection (see Note #3)
- C** Intumescent material (insulation)
- D** #10 steel screws or concrete anchors (see Note #5)
- E** Manual Locking Quadrant
- F** Grille/Diffuser
- G** Rear retaining angle (see Note #5)
- H** Typical 2 Hour Rated Vertical Wood Stud Construction



**VERTICAL MOUNT**

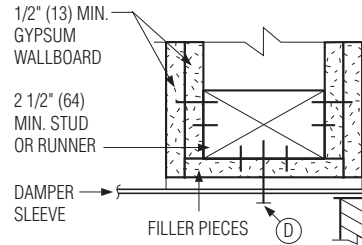

**H: Wood Stud Detail**

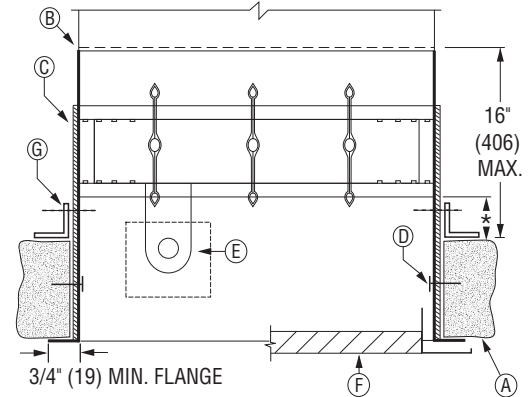

**HORIZONTAL MOUNT**

**QUALIFICATIONS:**

- Meets all the requirements of UL 555 and CAN/ULC-S112.
- Meets the requirements for NFPA 80, 90A and 101 as well as IBC and NBC (Canada) building codes.
- California State Fire Marshal Listing No. 03225-0935:0101.
- City of New York. MEA #366-03-M.

**\*NOTE:** Damper to be located maximum 8" (203) out of wall/floor.

**NOTES:**

**IMPORTANT: DAMPER IS FURNISHED FULL-SIZE (See Note #4)**

1. Installation shall be in accordance with the appropriate requirements of the National Fire Protection Association Standard NFPA 90A latest edition.
2. **Damper Sleeve:** Factory furnished sleeves shall not be less than 20 gauge. (1.01) coated steel. Sleeve thickness must be equal to or thicker than the duct connected to it. Sleeve gauge requirements are listed in the SMACNA Fire, Smoke and Radiation Damper Installation Guide for HVAC Systems and in NFPA 90A. If a break-away style duct/sleeve connection is not used, damper sleeves up to 36" wide by 24" (914 x 610) high of not less than 16 gauge (1.61) coated steel, or larger sleeves of not less than 14 gauge (1.99) thick coated steel may be attached to the duct with screws or other types of mechanical fasteners. The maximum sleeve thickness for such rigid joints is 10 gauge (3.51) for coated steel. The connecting duct shall not be continuous thru the wall or floor opening but shall terminate at the sleeve. Sleeves shall extend a maximum of 16" (406) from the wall.

**3. Break-away duct/sleeve connections:**

- a. Rectangular ducts must use one or more of the following connections if the gauge is less than the requirement in note 2 for rigid connections:

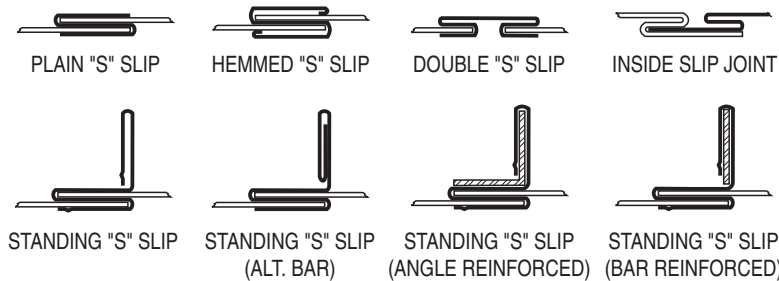

In addition:

- A maximum of two #10 sheet metal screws on each side and on the bottom, located in the center of the slip pocket and penetrating both sides of the slip pocket may be used.
- One of the above connections on the top and bottom joints with flat drive slip connections on the side joints may be used for dampers up to 20" (508) in height.



**FLAT DRIVE SLIP**

Dimensions are in inches (mm).

- b. Round or oval duct may be attached to the round or oval collar which is part of the damper/sleeve in the following manner:
- Duct diameters 22" (559) and smaller must use three #10 sheet metal screws equally spaced around the circumference.
  - Duct diameters over 22" (559) up to and including 36" (914) may use five #10 sheet metal screws equally spaced around the circumference.
  - Duct diameters larger than 36" (914) high or diameter may use eight #10 sheet metal screws equally spaced around the circumference.
- c. For the use of approved alternative Ductmate or TDC/TDF break-away connections, refer to the supplements noted on this page.
- Note:** When optional sealing of these break-away connections is desired, the duct sealant shall be PA2084T Duct Sealant by Precision or water based DP1010 by Design Polymetrics.
- 4. Opening Size:** Dampers are furnished full ordered size to facilitate grille installation. Opening size in partition should be sized 1/2" (13) larger in all directions to allow for sleeve thickness and insulation.
- 5. Fasteners and Retaining Angles.** For installation in a masonry wall or floor/ceiling and metal stud drywall partitions, no rear retaining angles are required. Insert damper/sleeve combination into opening so that the 3/4" (19) flange is tight to the drywall or concrete. Secure the damper in the wall opening from inside the sleeve as shown above by use of the following:
- In metal stud/drywall walls, partitions and cavity shaft wall partitions, use minimum #10 sheet metal screws.
  - In masonry walls or floor/ceilings use minimum #10 self-tapping concrete anchors. Anchors must penetrate wall minimum 1 1/2" (38).
  - In wood stud, use minimum #10 steel screws, 2 1/2" (64) long with minimum 1 1/2" (38) penetration into framing.
- Fasteners shall be spaced a maximum of 6" (152) on center and 2" (51) maximum from corners, a minimum of two per side is required.
- Alternatively, 1 1/2" x 1 1/2" x 16 gauge (38 x 38 x 1.61) rear retaining angles may be used in lieu of the above prescribed method and secured to the sleeve with 1/2" (12.7) long welds, 1/4" (6.35) dia. bolts and nuts, 3/16" (4.76) dia. steel rivets or #8 sheet metal screws, 8" (203) on center and 2" (51) maximum from corner of sleeve on all four sides.
- 6. Maximum Size Limitations:** Vertical: 36" x 48" (914 x 1219), Horizontal: 32" x 48" (813 x 1219). Minimum size is 8" x 8" (203 x 203).
- 7. Actuator and accessories:** Nailor multi-blade fire dampers are supplied with a hand locking quadrant as standard to hold blades in the open position. If MLS-300 position indicators are used, refer to the proper installation instructions for the MLS-300.

**REFER TO THE APPROPRIATE NAILOR INSTALLATION INSTRUCTION SUPPLEMENTS FOR ADDITIONAL INFORMATION OR SPECIAL REQUIREMENTS:**

MLS-300 (Honeywell) POSITION INDICATOR	MLS3H
MLS-300 (Nailor) POSITION INDICATOR	MLS3N
STEEL AND WOOD STUD FRAMING	FDSWSFINST
CAVITY SHAFT WALL PARTITIONS	FDCSWINST
FLANGED TYPE ALTERNATIVE BREAKAWAY CONNECTIONS	FDFABC
TDC/TDF FLANGED DUCT CONNECTION	FDTDCFINST
QUICK-SET RETAINING ANGLES	FQDSRA

Dimensions are in inches (mm).

Page 2 of 2



Houston, Texas  
Tel: 281-590-1172  
Fax: 281-590-3086

Las Vegas, Nevada  
Tel: 702-648-5400  
Fax: 702-638-0400

Toronto, Canada  
Tel: 416-744-3300  
Fax: 416-744-3360

Calgary, Canada  
Tel: 403-279-8619  
Fax: 403-279-5035