



DEPARTMENT OF REGULATORY AND ECONOMIC RESOURCES (RER)
BOARD AND CODE ADMINISTRATION DIVISION
NOTICE OF ACCEPTANCE (NOA)

MIAMI-DADE COUNTY
PRODUCT CONTROL SECTION
11805 SW 26 Street, Room 208
Miami, Florida 33175-2474
T (786) 315-2590 F (786) 315-2599
www.miamidade.gov/building

Nailor Industries Inc.
4714 Winfield Road
Houston, TX 77039

SCOPE:

This NOA is being issued under the applicable rules and regulations governing the use of construction materials. The documentation submitted has been reviewed and accepted by Miami-Dade County RER-Product Control Section to be used in Miami Dade County and other areas where allowed by the Authority Having Jurisdiction (AHJ).

This NOA shall not be valid after the expiration date stated below. The Miami-Dade County Product Control Section (In Miami Dade County) and/or the AHJ (in areas other than Miami Dade County) reserve the right to have this product or material tested for quality assurance purposes. If this product or material fails to perform in the accepted manner, the manufacturer will incur the expense of such testing and the AHJ may immediately revoke, modify, or suspend the use of such product or material within their jurisdiction. RER reserves the right to revoke this acceptance if it is determined by Miami-Dade County Product Control Section that this product or material fails to meet the requirements of the applicable building code.

This product is approved as described herein and has been designed to comply with the Florida Building Code, including the High Velocity Hurricane Zone.

DESCRIPTION: Model 1605HM Aluminum Louver

APPROVAL DOCUMENT: Drawing No. **NAI001**, titled "1605HM Louver", sheets 1 through 7 of 7, prepared by Building Drops, Inc., dated 07/14/2025, signed and sealed by Hermes F. Norero, P.E., bearing the Miami-Dade County Product Control approval stamp with the Notice of Acceptance number and expiration date by the Miami-Dade County Product Control Section.

MISSILE IMPACT RATING: Large and Small Missile Impact Resistant

LABELING: Each unit shall bear a permanent label with the manufacturer's name or logo, Houston, TX, model/series, and following statement: "Miami-Dade County Product Control Approved", unless otherwise noted herein.

RENEWAL of this NOA shall be considered after a renewal application has been filed and there has been no change in the applicable building code negatively affecting the performance of this product.

TERMINATION of this NOA will occur after the expiration date or if there has been a revision or change in the materials, use, and/or manufacture of the product or process. Misuse of this NOA as an endorsement of any product, for sales, advertising or any other purposes shall automatically terminate this NOA. Failure to comply with any section of this NOA shall be cause for termination and removal of NOA.

ADVERTISEMENT: The NOA number preceded by the words Miami-Dade County, Florida, and followed by the expiration date may be displayed in advertising literature. If any portion of the NOA is displayed, then it shall be done in its entirety.

INSPECTION: A copy of this entire NOA shall be provided to the user by the manufacturer or its distributors and shall be available for inspection at the job site at the request of the Building Official.

This NOA consists of this page 1 and evidence pages E-1, as well as approval document mentioned above. The submitted documentation was reviewed by **Carlos M. Utrera, P.E.**

03/10/26



NOA No. 25-1223.02
Expiration Date: March 19, 2031
Approval Date: March 19, 2026

Nailor Industries Inc.

NOTICE OF ACCEPTANCE: EVIDENCE SUBMITTED

A. DRAWINGS

1. Drawing No. **NAI001**, titled “1605HM Louver”, sheets 1 through 7 of 7, prepared by Building Drops, Inc., dated 07/14/2025, signed and sealed by Hermes F. Norero, P.E.

B. TESTS

1. Test reports on: 1) Uniform Static Air Pressure Test, Loading per FBC, TAS 202-94
2) Large Missile Impact Test per FBC, TAS 201-94
3) Cyclic Wind Pressure Loading per FBC, TAS 203-94
along with installation diagram of Model 1605 HM Louver System, prepared by Intertek, Test Report No. **S9127.01-801-18-r1**, dated 09/12/2025, reissued on 10/02/2025, signed and sealed by Tyler Westerling, P.E.
2. Test reports on Impact Test per AMCA 540-23/540-13, along with installation diagram of Model 1605HM Louver System, prepared by Intertek, Test Report No. **S9127.03-801-18-r0**, dated 10/02/2025, signed and sealed by Tyler Westerling, P.E.
3. Test Report on High Velocity Wind Driven Rain Resistance per ANSI/AMCA 550-22/550-15 on a Model 1605HM Louver, prepared by Intertek, Test Report No. **S3613.01-801-44 R1**, dated 04/17/2025, with revision dated 09/15/2025, signed and sealed by Tyler Westerling, P.E.

C. CALCULATIONS

1. Product Evaluation Report, prepared by Building Drops, Inc., dated 12/11/2025, signed and sealed by Hermes F. Norero, P.E.

D. QUALITY ASSURANCE

1. Miami-Dade Department of Regulatory and Economic Resources (RER).

E. MATERIAL CERTIFICATIONS

1. None.

F. STATEMENTS

1. Statement letter of code conformance to the 8th edition (2023) of the FBC, issued by Building Drops, Inc., dated 12/11/2025, signed and sealed by Hermes F. Norero, P.E.
2. Statement letter of no financial interest issued by Building Drops, Inc., dated 12/11/2025, signed and sealed by Hermes F. Norero, P.E.



Carlos M. Utrera, P.E.
Product Control Examiner
NOA No. 25-1223.02
Expiration Date: March 19, 2031
Approval Date: March 19, 2026

NAILOR INDUSTRIES, INC.

1605HM LOUVER (HVHZ)(IMPACT)



4714 WINFIELD ROAD
HOUSTON, TX 77039
PH: 281-590-1172

GENERAL NOTES:

- THE PRODUCT SHOWN HEREIN IS DESIGNED AND MANUFACTURED TO COMPLY WITH THE 8TH EDITION (2023) OF THE FLORIDA BUILDING CODE (FBC), INCLUDING HVHZ AND HAS BEEN EVALUATED ACCORDING TO THE FOLLOWING:
 - AMCA 550-15
 - AMCA 540-13
 - TAS 201-94
 - TAS 202-94
 - TAS 203-94
- ADEQUACY OF THE EXISTING STRUCTURAL CONCRETE/MASONRY, 2X FRAMING, AND METAL FRAMING AS A MAIN WIND FORCE RESISTING SYSTEM CAPABLE OF WITHSTANDING AND TRANSFERRING APPLIED PRODUCT LOADS TO THE FOUNDATION IS THE RESPONSIBILITY OF THE ENGINEER OR ARCHITECT OF RECORD FOR THE PROJECT OF INSTALLATION.
- 1X AND 2X BUCKS (WHEN USED) SHALL BE DESIGNED AND ANCHORED TO PROPERLY TRANSFER ALL LOADS TO THE STRUCTURE. BUCK DESIGN AND INSTALLATION IS THE RESPONSIBILITY OF THE ENGINEER OR ARCHITECT OF RECORD FOR THE PROJECT OF INSTALLATION.
- INSTALL INDIVIDUAL INSTALLATION ANCHORS WITHIN A TOLERANCE OF ±1/2 INCH OF THE DEPICTED LOCATION IN THE ANCHOR LAYOUT DETAIL (I.E., WITHOUT CONSIDERATION OF TOLERANCES). TOLERANCES ARE NOT CUMULATIVE FROM ONE INSTALLATION ANCHOR TO THE NEXT.
- THE INSTALLATION DETAILS DESCRIBED HEREIN ARE GENERIC AND MAY NOT REFLECT ACTUAL CONDITIONS FOR A SPECIFIC SITE. IF SITE CONDITIONS CAUSE INSTALLATION TO DEVIATE FROM THE REQUIREMENTS DETAILED HEREIN, A LICENSED ENGINEER OR ARCHITECT SHALL PREPARE SITE SPECIFIC DOCUMENTS FOR USE WITH THIS DOCUMENT.
- APPROVED IMPACT PROTECTIVE SYSTEM **IS NOT REQUIRED** ON THIS PRODUCT IN AREAS REQUIRING IMPACT RESISTANCE.
- LOUVER MATERIAL: ALUMINUM 6063-T6

TABLE OF CONTENTS	
SHEET	SHEET DESCRIPTION
1	GENERAL NOTES
2	ELEVATION
3	ANCHOR LAYOUT
4	VERTICAL SECTIONS
5	HORIZONTAL SECTIONS
6	ANCHOR DETAILS & INSTALLATION NOTES
7	BILL OF MATERIALS & COMPONENTS

DESIGN PRESSURE RATING (PSF)			
WIDTH (IN.)	HEIGHT (IN.)	DESIGN PRESSURE	MISSILE IMPACT RATING
60	120	+100/-100	LARGE MISSILE LEVEL E

TITLE: 1605HM LOUVER (HVHZ) (IMPACT)

GENERAL NOTES

PREPARED BY: BUILDING DROPS, INC.
1900 NE MIAMI COURT, STE. 2-15
MIAMI, FL 33132
PH: (954)399-8478
FAX: (954)744-4738
WEB: www.buildingdrops.com



REMARKS	BY	DATE

THE INSTALLATION DETAILS DESCRIBED HEREIN ARE GENERIC AND MAY NOT REFLECT ACTUAL CONDITIONS FOR A SPECIFIC SITE. IF SITE CONDITIONS CAUSE INSTALLATION TO DEVIATE FROM THE REQUIREMENTS DETAILED HEREIN, A LICENSED ENGINEER OR ARCHITECT SHALL PREPARE SITE SPECIFIC DOCUMENTS FOR USE WITH THIS DOCUMENT.

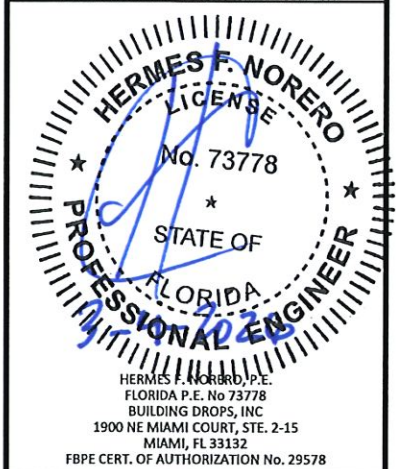

PRODUCT APPROVED
as complying with the Florida
Building Code
NOA-No. 25-1223.02
Approval Date 03/19/2026
By *[Signature]*
Miami-Dade Product Control

DATE: 07.14.25
DWG. BY: DB
CHK. BY: HFN
SCALE: NTS
DWG. #: NAI001
SHEET:

1

OF 7



4714 WINFIELD ROAD
HOUSTON, TX 77039
PH: 281-590-1172

TITLE: 1605HM LOUVER (HVHZ) (IMPACT) ELEVATION

PREPARED BY: BUILDING DROPS, INC.
1900 NE MIAMI COURT, STE. 2-15
MIAMI, FL 33132
PH: (954)399-8478
FAX: (954)744-4738
WEB: www.buildingdrops.com



REMARKS	BY	DATE

THE INSTALLATION DETAILS DESCRIBED HEREIN ARE GENERIC AND MAY NOT REFLECT ACTUAL CONDITIONS FOR A SPECIFIC SITE. IF SITE CONDITIONS CAUSE INSTALLATION TO DEVIATE FROM THE REQUIREMENTS DETAILED HEREIN, A LICENSED ENGINEER OR ARCHITECT SHALL PREPARE SITE SPECIFIC DOCUMENTS FOR USE WITH THIS DOCUMENT.

HERMES F. NORERO, P.E.
FLORIDA P.E. No. 73778
BUILDING DROPS, INC.
1900 NE MIAMI COURT, STE. 2-15
MIAMI, FL 33132
FBPE CERT. OF AUTHORIZATION No. 29578

DATE:	07.14.25
DWG. BY:	DB
CHK. BY:	HFN
SCALE:	NTS
DWG. #:	NAI001
SHEET:	2 OF 7

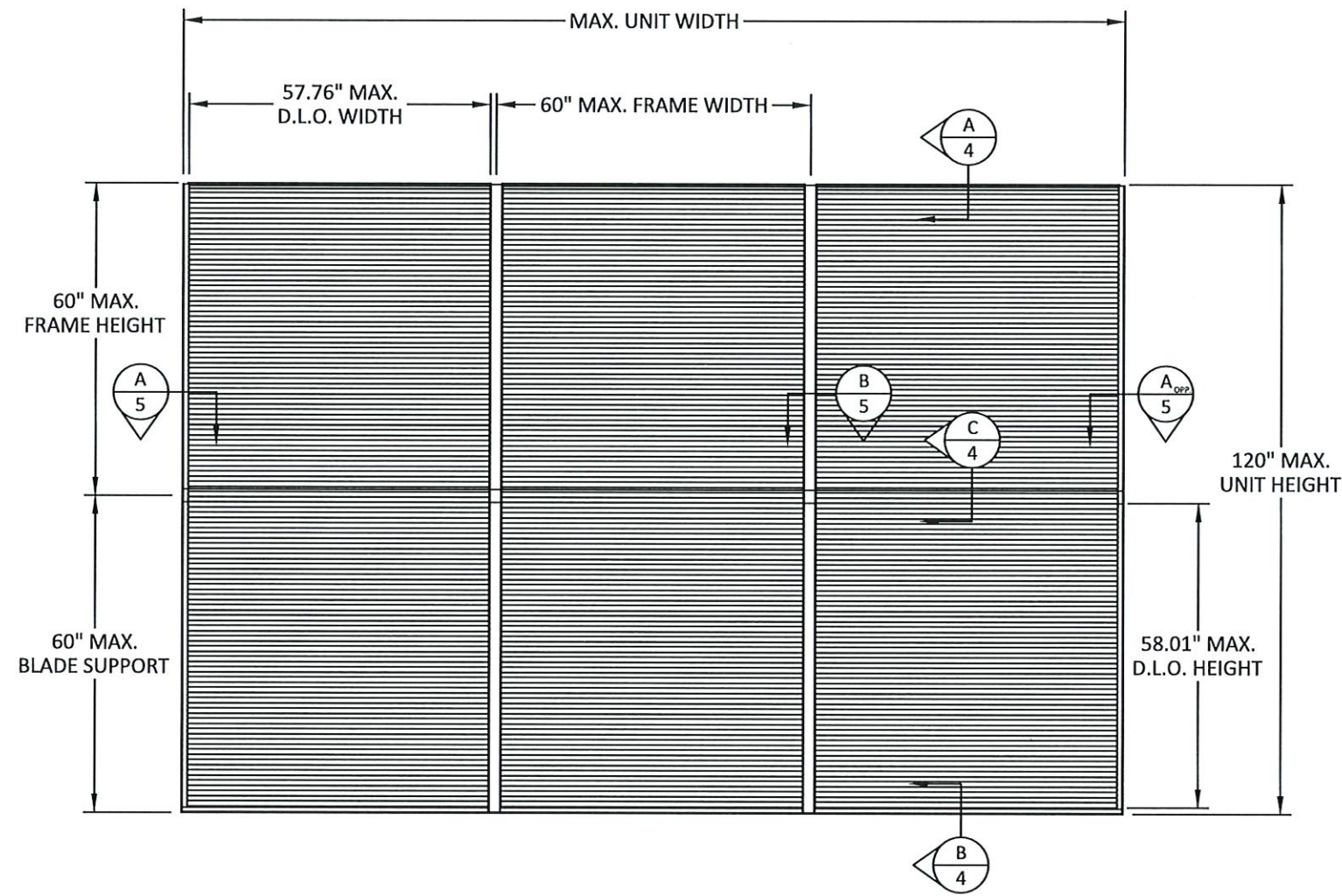

ELEVATION

PRODUCT APPROVED
as complying with the Florida Building Code
NOA-No. 25-1223.02
Approval Date 03/19/2026
By *[Signature]*
Miami-Dade Product Control

c:\users\ludensanchez\building_drops, inc\building_drops\common\projects\nailor_industries\mdc-25-0461 - mdc submittal - 1605hm_louver.dwg\naio01.dwg 2/17/2025 4:03 PM

c:\users\ludanosanchez\building_drops, inc\building_drops landing - documents\common\projects\nailor industries\mdc-25-0461 - mdc submittal - 1605hm louver\dwgs\nai001.dwg 2/17/2026 4:03 PM

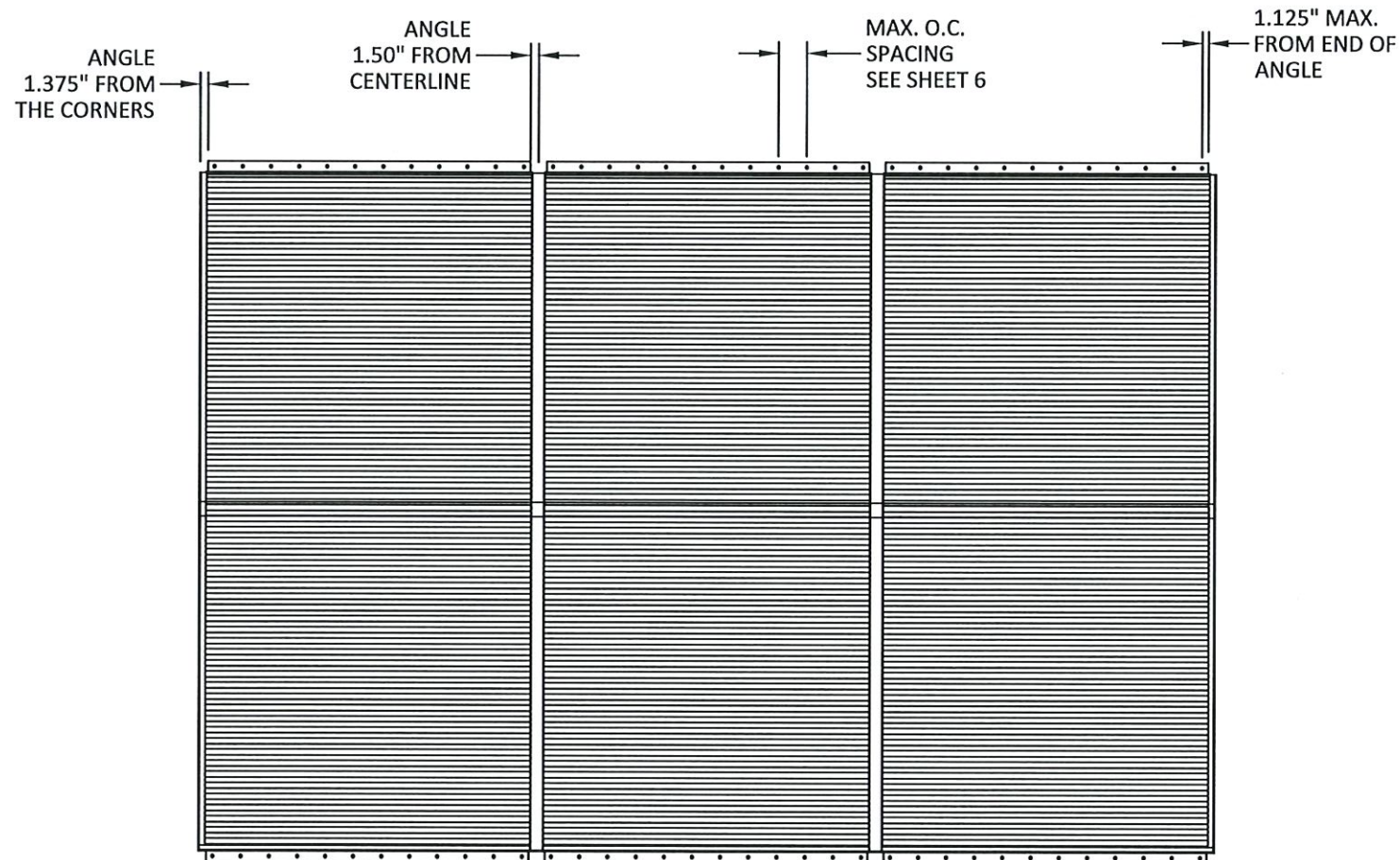

ANCHOR LAYOUT
ANGLE INSTALLATION

PRODUCT APPROVED
as complying with the Florida Building Code
NOA-No. 25-1223.02
Approval Date 03/19/2026
By *[Signature]*
Miami-Dade Product Control



4714 WINFIELD ROAD
HOUSTON, TX 77039
PH: 281-590-1172

TITLE: 1605HM LOUVER (HVHZ) (IMPACT)
ANCHOR LAYOUT

PREPARED BY: BUILDING DROPS, INC.
1900 NE MIAMI COURT, STE. 2-15
MIAMI, FL 33132
PH: (954)399-8478
FAX: (954)744-4738
WEB: www.buildingdrops.com



REMARKS	BY	DATE

THE INSTALLATION DETAILS DESCRIBED HEREIN ARE GENERIC AND MAY NOT REFLECT ACTUAL CONDITIONS FOR A SPECIFIC SITE. IF SITE CONDITIONS CAUSE INSTALLATION TO DEVIATE FROM THE REQUIREMENTS DETAILED HEREIN, A LICENSED ENGINEER OR ARCHITECT SHALL PREPARE SITE SPECIFIC DOCUMENTS FOR USE WITH THIS DOCUMENT.

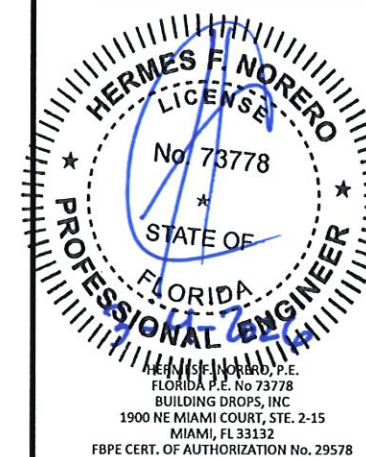

DATE: 07.14.25

DWG. BY: DB CHK. BY: HFN

SCALE: NTS

DWG. #: NAI001

SHEET: 3

OF 7

2/17/2026 4:03 PM

c:\users\lucianosanchez\building drops, inc\building drops landing - documents\common\projects\nailor industries\mdc-25-0461 - mdc submittal - 1605hm louvers\dwgshai001.dwg



4714 WINFIELD ROAD
HOUSTON, TX 77039
PH: 281-590-1172

TITLE: 1605HM LOUVER (HVHZ) (IMPACT)
VERTICAL SECTIONS

PREPARED BY: BUILDING DROPS, INC.
1900 NE MIAMI COURT, STE. 2-15
MIAMI, FL 33132
PH: (954)399-8478
FAX: (954)744-4738
WEB: www.buildingdrops.com



REMARKS	BY	DATE

THE INSTALLATION DETAILS DESCRIBED HEREIN ARE GENERIC AND MAY NOT REFLECT ACTUAL CONDITIONS FOR A SPECIFIC SITE. IF SITE CONDITIONS CAUSE INSTALLATION TO DEVIATE FROM THE REQUIREMENTS DETAILED HEREIN, A LICENSED ENGINEER OR ARCHITECT SHALL PREPARE SITE SPECIFIC DOCUMENTS FOR USE WITH THIS DOCUMENT.

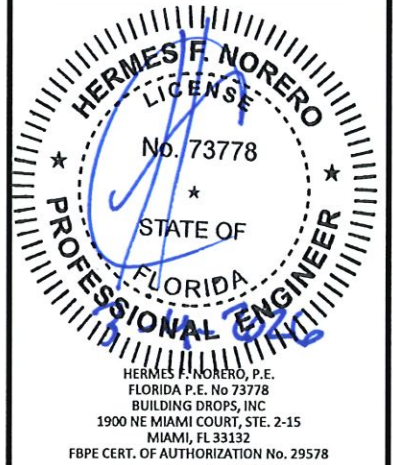

HERMES F. NORERO, P.E.
FLORIDA P.E. No. 73778
BUILDING DROPS, INC.
1900 NE MIAMI COURT, STE. 2-15
MIAMI, FL 33132
FBPE CERT. OF AUTHORIZATION No. 29578

DATE:	07.14.25
DWG. BY:	DB
CHK. BY:	HFN
SCALE:	NTS
DWG. #:	NAI001
SHEET:	4

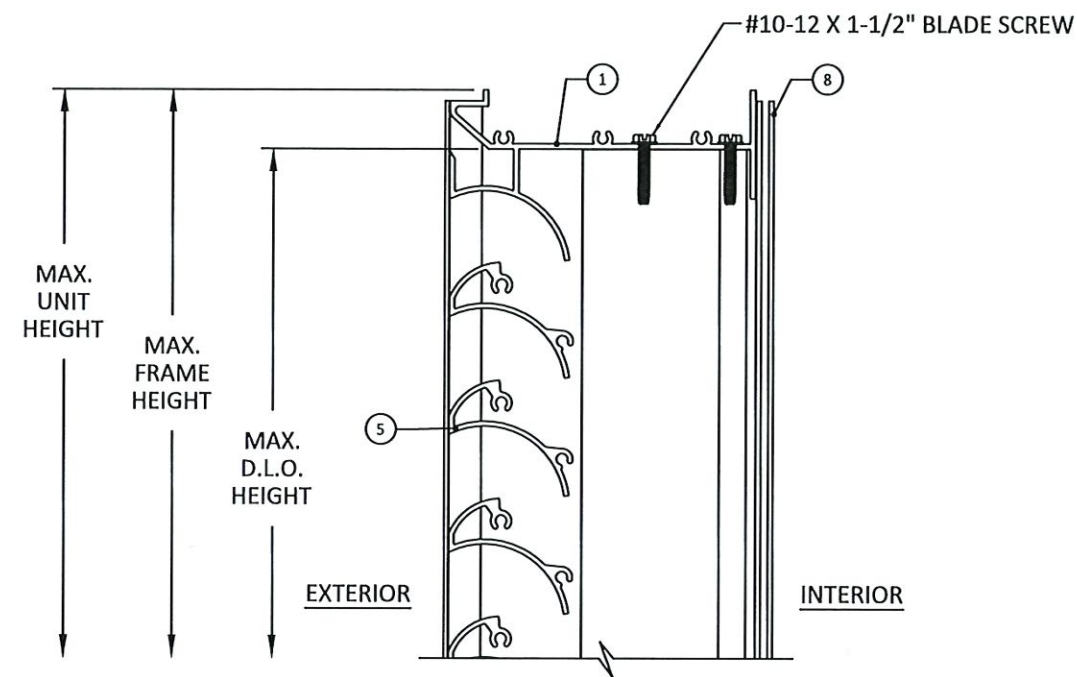

A
4 VERTICAL SECTION

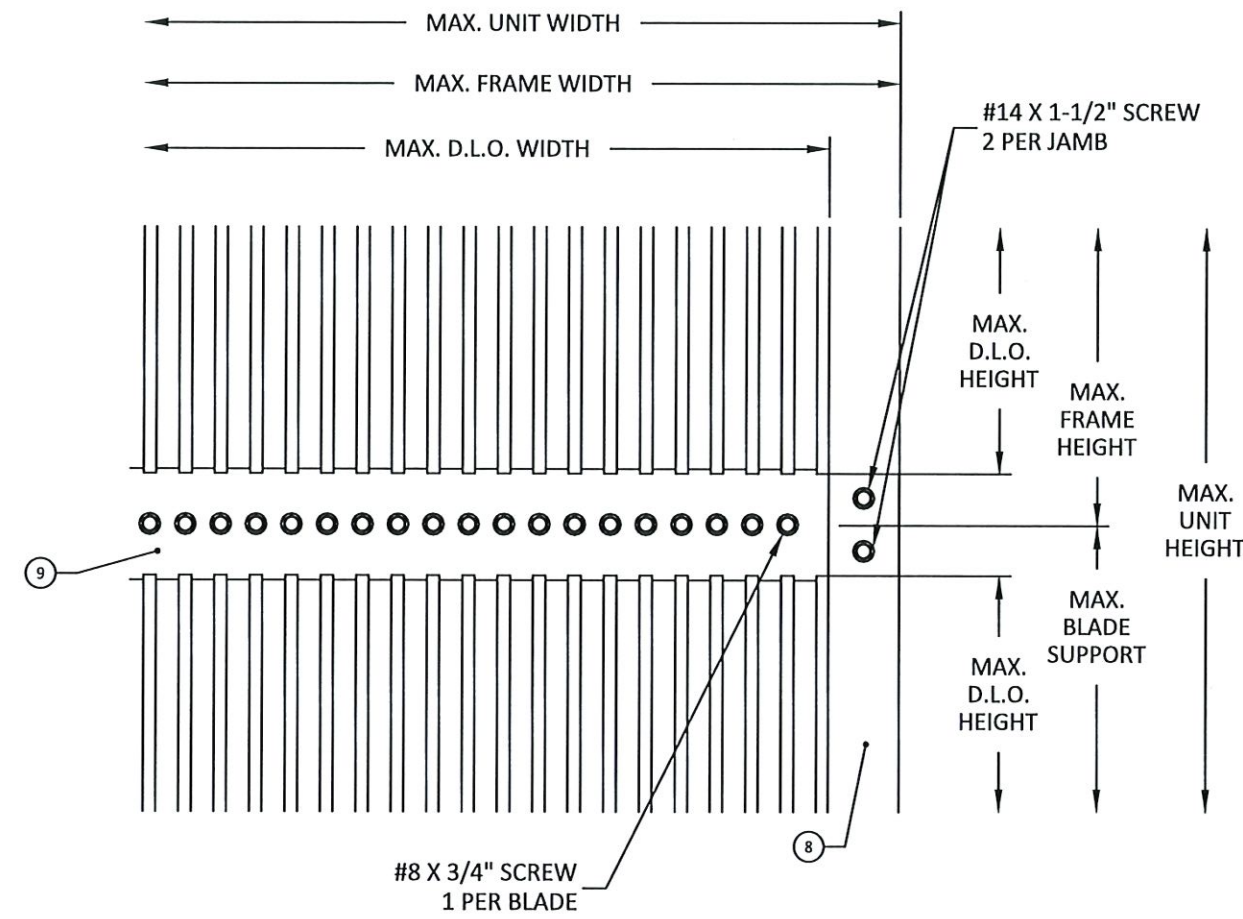

C
4 VERTICAL SECTION
BACK VIEW

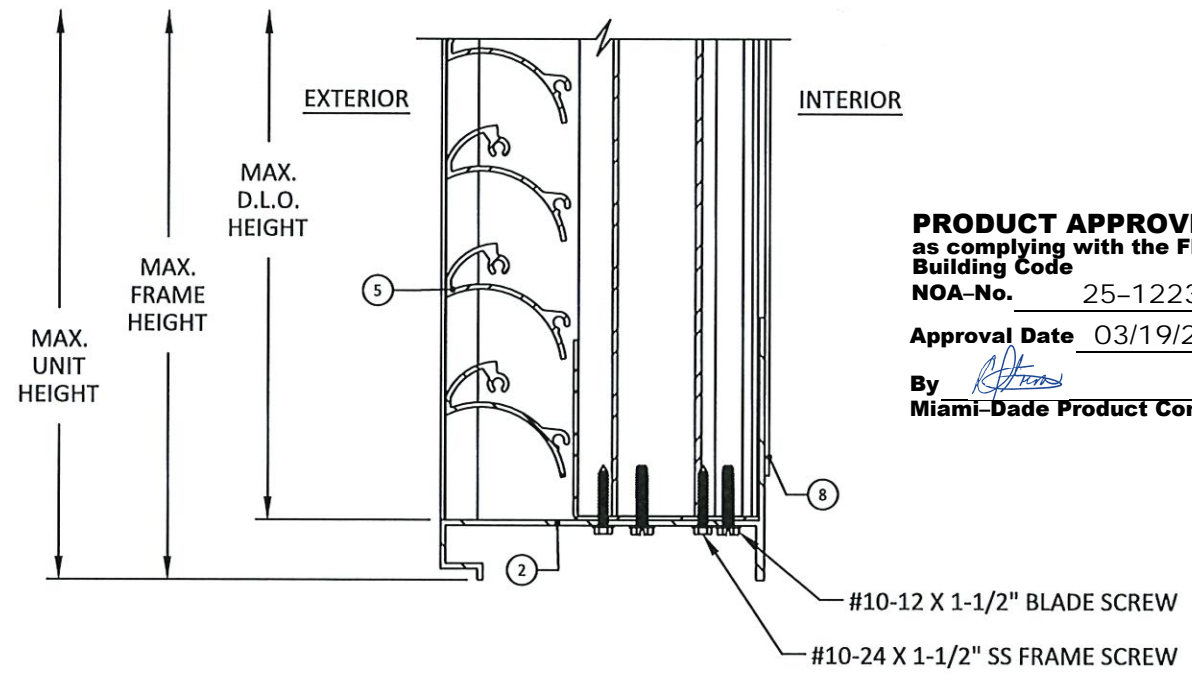

B
4 VERTICAL SECTION

PRODUCT APPROVED
as complying with the Florida
Building Code
NOA-No. 25-1223.02
Approval Date 03/19/2026
By *[Signature]*
Miami-Dade Product Control

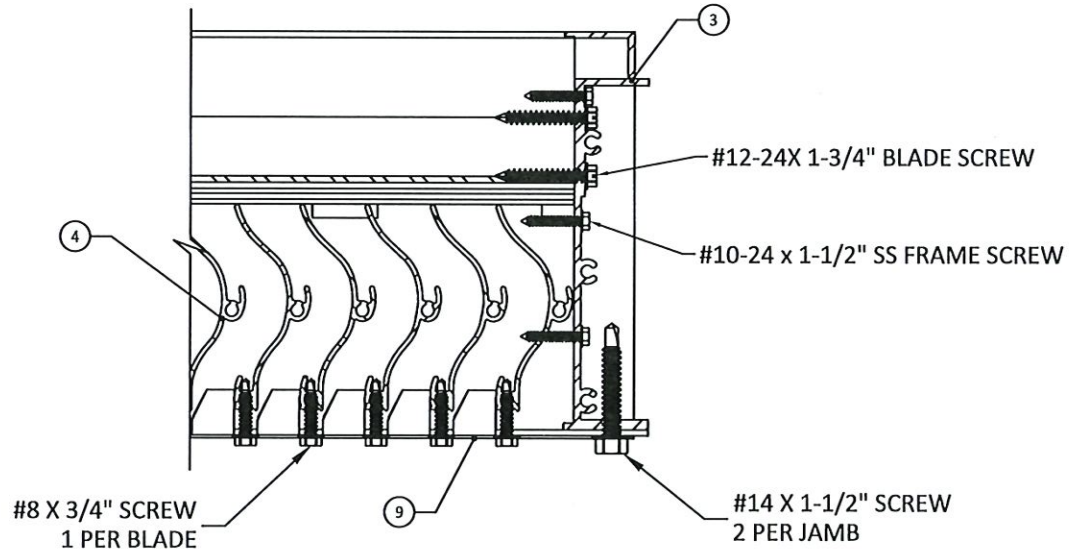

D
4 HORIZONTAL SECTION
BLADE SUPPORT

c:\users\lucianosanchez\building_drops, inc\building_drops_landing - documents\common\projects\nailor_industries\mdc-25-0461 - mdc_submittal - 1605hm_louver\dwg\hna001.dwg 2/17/2026 4:03 PM



4714 WINFIELD ROAD
HOUSTON, TX 77039
PH: 281-590-1172

TITLE: 1605HM LOUVER (HVHZ) (IMPACT)
HORIZONTAL SECTIONS

PREPARED BY: BUILDING DROPS, INC.
1900 NE MIAMI COURT, STE. 2-15
MIAMI, FL 33132
PH: (954) 959-8478
FAX: (954) 744-4738
WEB: www.buildingdrops.com



REMARKS	BY	DATE

THE INSTALLATION DETAILS DESCRIBED HEREIN ARE GENERIC AND MAY NOT REFLECT ACTUAL CONDITIONS FOR A SPECIFIC SITE. IF SITE CONDITIONS CAUSE INSTALLATION TO DEVIATE FROM THE REQUIREMENTS DETAILED HEREIN, A LICENSED ENGINEER OR ARCHITECT SHALL PREPARE SITE SPECIFIC DOCUMENTS FOR USE WITH THIS DOCUMENT.

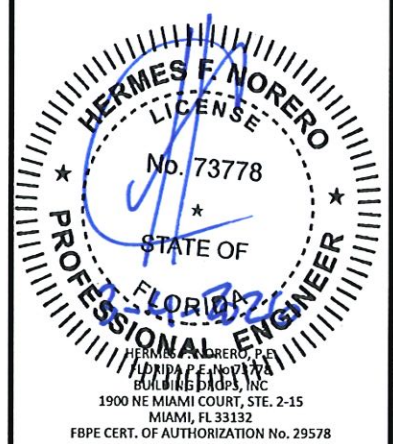

DATE:	07.14.25
DWG. BY:	DB
CHK. BY:	HFN
SCALE:	NTS
DWG. #:	NAI001
SHEET:	5

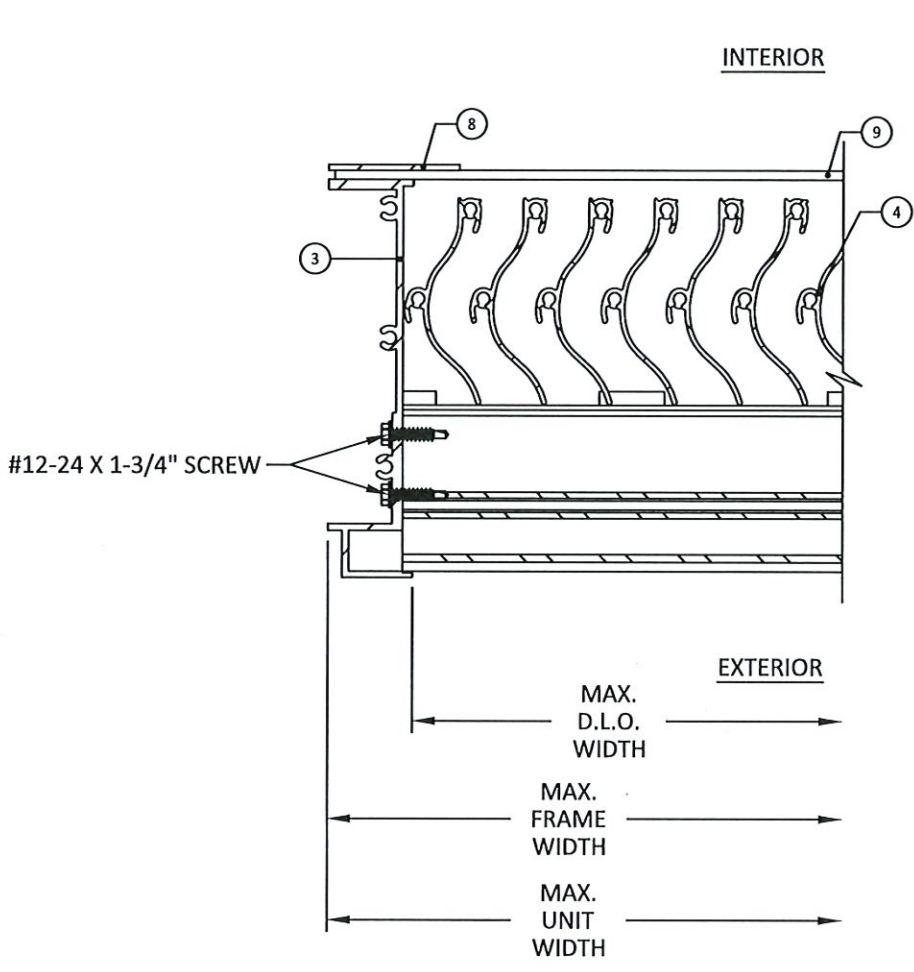

A HORIZONTAL SECTION
5

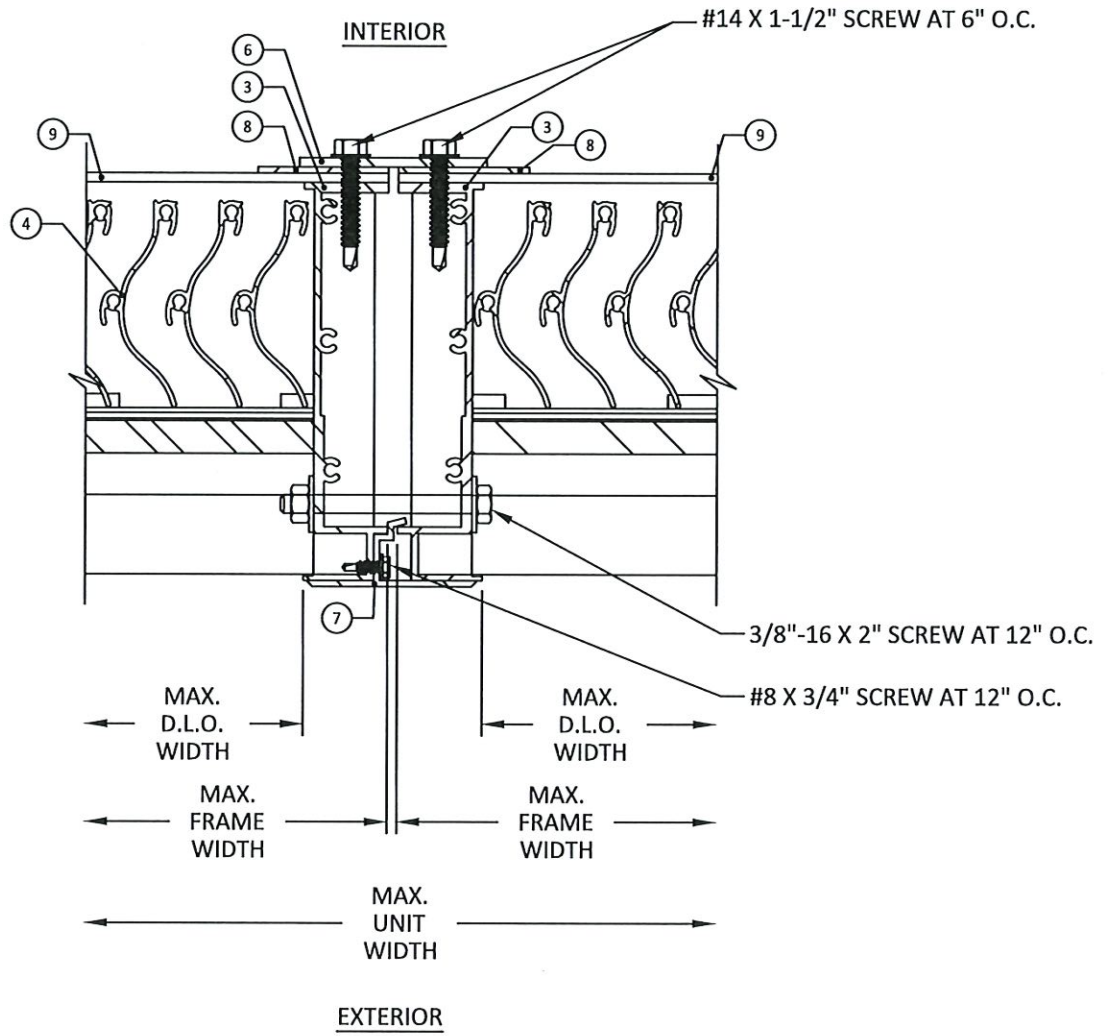

B HORIZONTAL SECTION
5

PRODUCT APPROVED
as complying with the Florida
Building Code
NOA-No. 25-1223.02
Approval Date 03/19/2026
By *[Signature]*
Miami-Dade Product Control

c:\users\lucianosanchez\building drops - documents\common\projects\nailor industries\mdc-25-0461 - mdc submittal - 1605hm louver\dwgs\nai001.dwg 2/17/2026 4:03 PM

NOTE: 2" X 3" ALUMINUM ANGLE SHOWN,
2" X 2" ALUMINUM ANGLE QUALIFIED

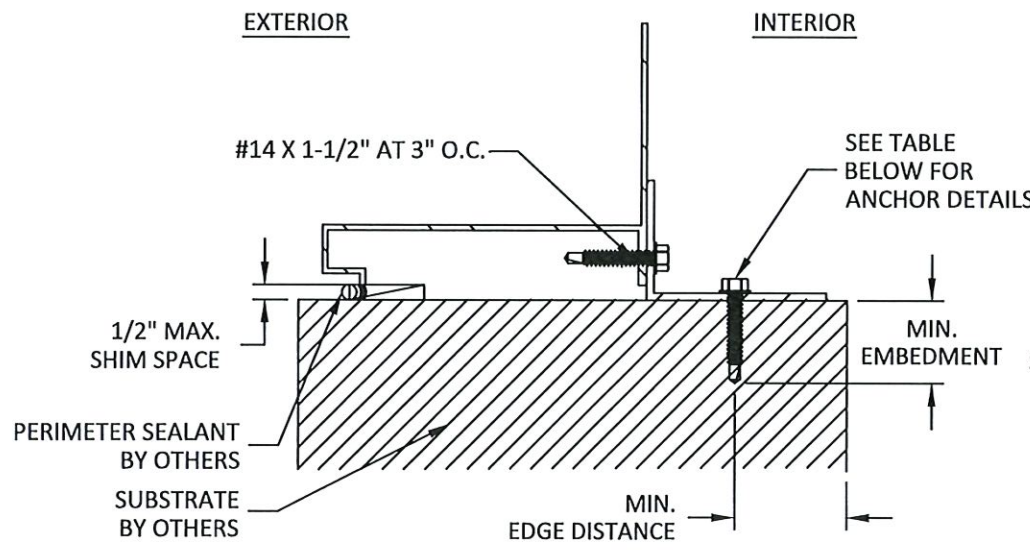

A
6 **ANCHOR DETAIL**
INTERIOR ANGLE
SILL SHOWN, HEAD SIMILAR

PRODUCT APPROVED
as complying with the Florida
Building Code
NOA-No. 25-1223.02
Approval Date 03/19/2026
By *[Signature]*
Miami-Dade Product Control

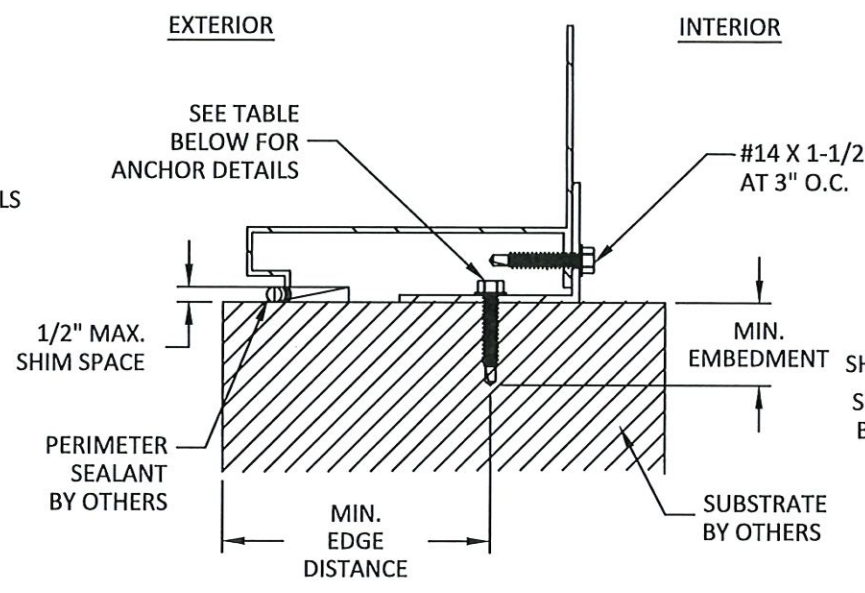

B
6 **ANCHOR DETAIL**
EXTERIOR ANGLE
SILL SHOWN, HEAD SIMILAR

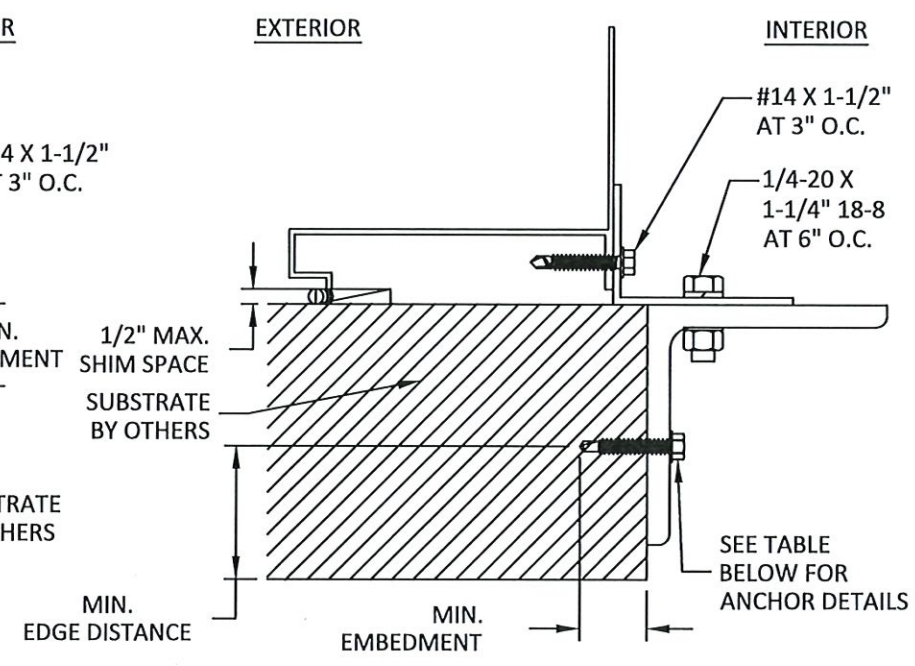

C
7 **ANCHOR DETAIL**
EXTERIOR ANGLE TO ANGLE
SILL SHOWN, HEAD SIMILAR

INSTALLATION NOTES:

- ONE (1) INSTALLATION ANCHOR IS REQUIRED AT EACH ANCHOR LOCATION SHOWN, UNLESS OTHERWISE STATED ON SHEET 3.
- INSTALL INDIVIDUAL INSTALLATION ANCHORS WITHIN A TOLERANCE OF ±1/2 INCH THE DEPICTED LOCATION & SPACING IN THE ANCHOR LAYOUT DETAILS (I.E., WITHOUT CONSIDERATION OF TOLERANCES). TOLERANCES ARE NOT CUMULATIVE FROM ONE INSTALLATION ANCHOR TO THE NEXT.
- SHIM AS REQUIRED AT EACH INSTALLATION ANCHOR WITH LOAD BEARING SHIM(S). MAXIMUM ALLOWABLE SHIM STACK TO BE 1/4 INCH. SHIM WHERE SPACE OF 1/16 INCH OR GREATER OCCURS. SHIM(S) SHALL BE CONSTRUCTED OF HIGH DENSITY PLASTIC OR BETTER.
- MINIMUM EMBEDMENT AND EDGE DISTANCE EXCLUDE WALL FINISHES, INCLUDING BUT NOT LIMITED TO STUCCO, FOAM, BRICK VENEER, AND SIDING.
- INSTALLATION ANCHORS AND ASSOCIATED HARDWARE MUST BE MADE OF CORROSION RESISTANT MATERIAL OR HAVE A CORROSION RESISTANT COATING.
- FOR MASONRY OR CONCRETE OPENINGS, A 1X WOOD BUCK MAY BE USED (OPTIONAL) AS LONG AS THE MINIMUM EMBEDMENT AND EDGE DISTANCE REQUIREMENTS ARE STILL MET WITHIN THE CORRESPONDING HOST SUBSTRATE. SEE GENERAL NOTE #3 ON SHEET 1 FOR MORE INFORMATION.
- FOR HOLLOW BLOCK AND GROUT FILLED BLOCK, DO NOT INSTALL INSTALLATION ANCHORS INTO MORTAR JOINTS. EDGE DISTANCE IS MEASURED FROM FREE EDGE OF BLOCK OR EDGE OF MORTAR JOINT INTO FACE SHELL OF BLOCK.
- INSTALLATION ANCHORS SHALL BE INSTALLED IN ACCORDANCE WITH ANCHOR MANUFACTURER'S INSTALLATION INSTRUCTIONS, AND ANCHORS SHALL NOT BE USED IN SUBSTRATES WITH STRENGTHS LESS THAN THE MINIMUM STRENGTH SPECIFIED BY THE ANCHOR MANUFACTURER.

ANCHOR SCHEDULE					
METHOD	SUBSTRATE	ANCHOR TYPE	MIN. EMBEDMENT	MIN. EDGE DISTANCE	MAX. O.C. SPACING
ANGLE	WOOD: MIN. SG = 0.55	#14 WOOD SCREW	1.50"	0.75"	5"
	METAL: 18 GAUGE STEEL, MIN. Fy = 33KSI ALUMINUM: 1/8" MIN., 6063-T5	1/4" SELF-DRILLING SCREW	3 THREADS MIN. PENETRATION BEYOND STRUCTURE	0.50"	5"
	CONCRETE: f'c=3000PSI	1/4" ITW TAPCON	1.00"	3.00"	5"
	MASONRY: CMU per ASTM C90 MIN. 2000 PSI	1/4" ITW TAPCON	1.00"	3.00"	5"
ANGLE TO ANGLE	WOOD: MIN. SG = 0.55	#14 WOOD SCREW	1.50"	0.75"	4.50"
	METAL: 18 GAUGE STEEL, MIN. Fy = 33KSI ALUMINUM: 1/8" MIN., 6063-T5	1/4" SELF-DRILLING SCREW	3 THREADS MIN. PENETRATION BEYOND STRUCTURE	0.50"	4.50"
	CONCRETE: f'c=3000PSI	1/4" ITW TAPCON	1.00"	2.50"	4.50"
	MASONRY: CMU per ASTM C90 MIN. 2000 PSI	1/4" ITW TAPCON	1.00"	2.50"	2"



4714 WINFIELD ROAD
HOUSTON, TX 77039
PH: 281-590-1172

TITLE:
1605HM LOUVER (HVHZ) (IMPACT)
ANCHOR DETAILS & INSTALLATION NOTES

PREPARED BY:
BUILDING DROPS, INC.
1900 NE MIAMI COURT, STE. 2-15
MIAMI, FL 33132
PH: (954) 939-8478
FAX: (954) 744-4738
WEB: www.buildingdrops.com

REMARKS	BY	DATE

THE INSTALLATION DETAILS DESCRIBED HEREIN ARE GENERIC AND MAY NOT REFLECT ACTUAL CONDITIONS FOR A SPECIFIC SITE. IF SITE CONDITIONS CAUSE INSTALLATION TO DEVIATE FROM THE REQUIREMENTS DETAILED HEREIN, A LICENSED ENGINEER OR ARCHITECT SHALL PREPARE SITE SPECIFIC DOCUMENTS FOR USE WITH THIS DOCUMENT.

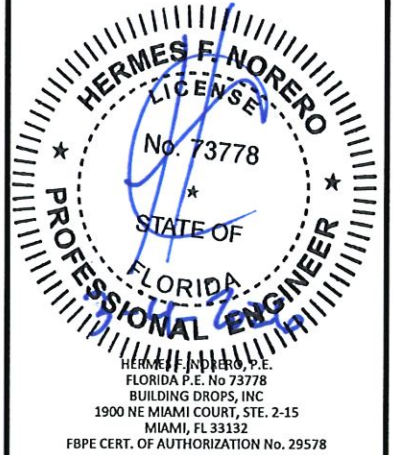

DATE: 07.14.25

DWG. BY: DB CHK. BY: HFN

SCALE: NTS

DWG. #: NAI001

SHEET:

6

OF 7

BILL OF MATERIALS			
ITEM	PART NO.	DESCRIPTION	MATERIAL
1	C6-247	HEAD	ALUMINUM 6063-T6
2	C6-249	SILL	ALUMINUM 6063-T6
3	C6-248	JAMB	ALUMINUM 6063-T6
4	C6-245	VERTICAL BLADE	ALUMINUM 6063-T6
5	C6-246	HORIZONTAL BLADE	ALUMINUM 6063-T6
6	-	MULLION BAR	ALUMINUM 6063-T6
7	C6-173	MULLION COVER	ALUMINUM 6063-T6
8	-	BLANK-OFF	ALUMINUM 6063-T6
9	-	BLADE SUPPORT	ALUMINUM 6063-T6
10	-	2" X 3" ANGLE	ALUMINUM 6063-T5
11	-	2" X 2" ANGLE	ALUMINUM 6063-T5
12	C6-221B	4" X 4" ANGLE	ALUMINUM 6063-T6

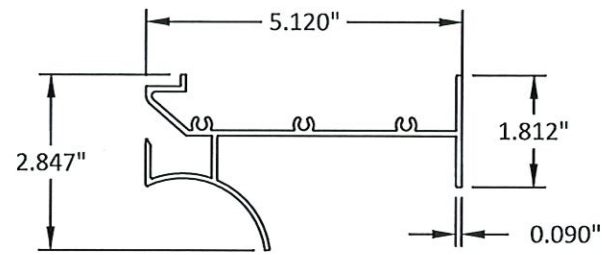

1 HEAD

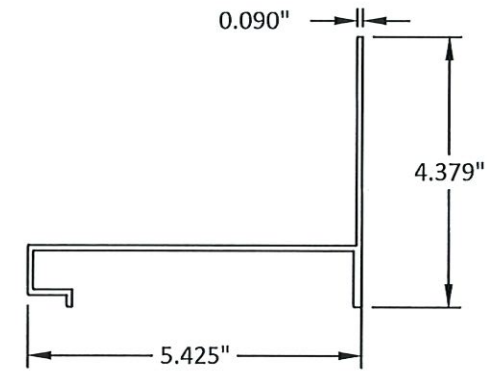

2 SILL

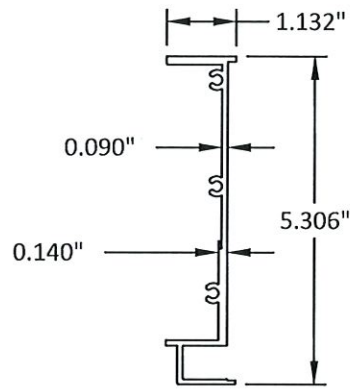

3 JAMB

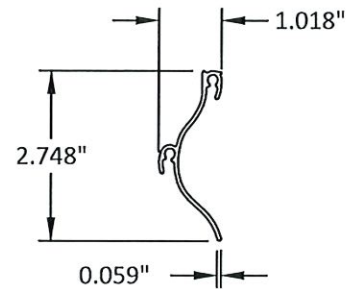

4 V. BLADE

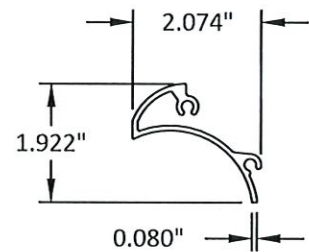

5 H. BLADE



6 MULLION BAR

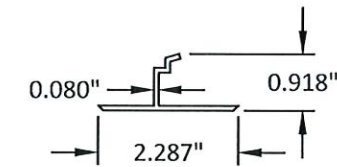

7 MULLION COVER

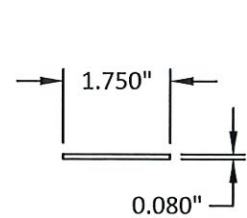

8 BLANK-OFF

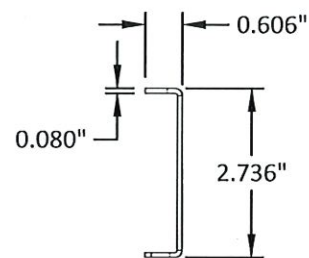

9 BLADE SUPPORT

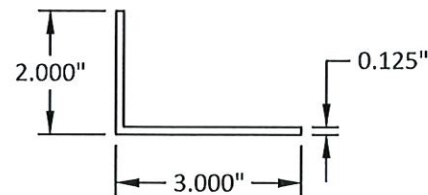

10 2" X 3" ANGLE

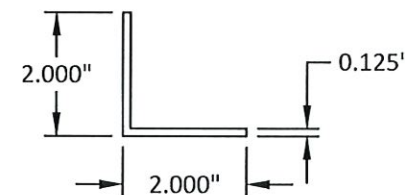

11 2" X 2" ANGLE

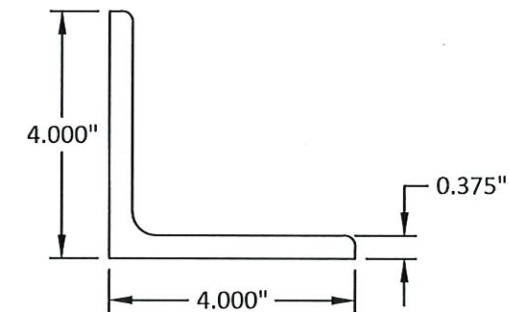

12 4" X 4" ANGLE

PRODUCT APPROVED
as complying with the Florida
Building Code
NOA-No. 25-1223.02
Approval Date 03/19/2026
By *[Signature]*
Miami-Dade Product Control



4714 WINFIELD ROAD
HOUSTON, TX 77039
PH: 281-590-1172

TITLE: 1605HM LOUVER
(HVHZ) (IMPACT)
BILL OF MATERIALS
& COMPONENTS

PREPARED BY: BUILDING DROPS, INC.
1900 NE MIAMI COURT, STE. 2-15
MIAMI, FL 33132
PH: (954)395-8478
FAX: (954)744-4738
WEB: www.buildingdrops.com



REMARKS	BY	DATE

THE INSTALLATION DETAILS DESCRIBED HEREIN ARE GENERAL AND MAY NOT REFLECT ACTUAL CONDITIONS FOR A SPECIFIC SITE. IF SITE CONDITIONS CAUSE INSTALLATION TO DEVIATE FROM THE REQUIREMENTS DETAILED HEREIN, A LICENSED ENGINEER OR ARCHITECT SHALL PREPARE SITE SPECIFIC DOCUMENTS FOR USE WITH THIS DOCUMENT.

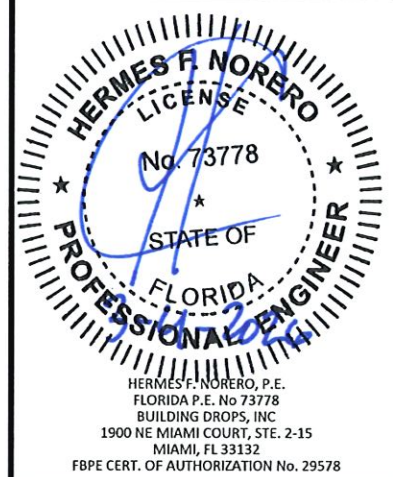

DATE:	07.14.25
DWG. BY:	DB
CHK. BY:	HFN
SCALE:	NTS
DWG. #:	NAI001
SHEET:	7