

FIBERGLASS DUCTBOARD PLENUM:

- (A) Fiberglass ductboard plenum, by others.
- (B) Steel frame Grille/Diffuser, 26 ga. (0.55) minimum, see note 6
- (C) 3/4" x 3/4" x 16 ga. (19 x 19 x 1.61) or 1 1/2" x 1 1/2" x 22 ga. (38 x 38 x 0.85) Support Angle (2 sides), see notes 2 & 3
- (D) Flex Duct UL Classified Air Duct (Class 0 or 1)
- (E) Wood Truss (refer to specific UL Design No.)
- (F) 5/8" (16) Gypsum Wallboard (refer to specific UL Design No.)
- (G) RC Channel
- (H) Plaster Flange
- (I) 1" x 1" x 22 ga. (25 x 25 x .85) Retaining Angle (min.) on all 4 sides
- (J) Air Duct
- (K) Ceiling Damper (1 or 2 blades, or curtain type)

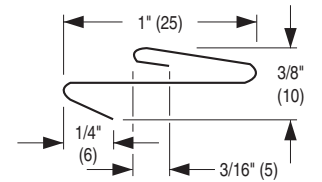

Standard 26 Ga. Boot Rail
Alternate installation using standard boot rail.
Model 0757 only with 1 or 2 blade or curtain type damper.

Damper may be installed using standard boot rail.

Rails to be installed on opposite sides of boot and attached to the bottom cord of the truss using 16D nails or screws a minimum of 2" (51) long. Max. size 14" x 8" (356 x 203).

Opening Sizes:

Minimum	Maximum
6" W x 4" H (152 x 102)	21" W x 18" H (533 x 457)

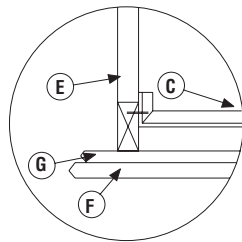

DETAIL B

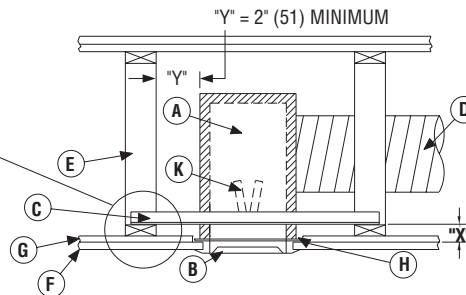

END VIEW WITH GRILLE (0757)

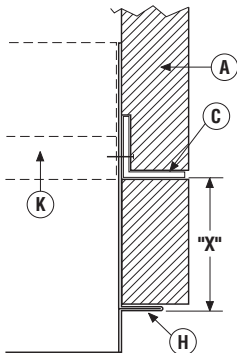

DETAIL A

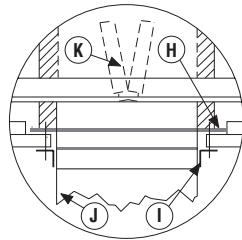

DETAIL C

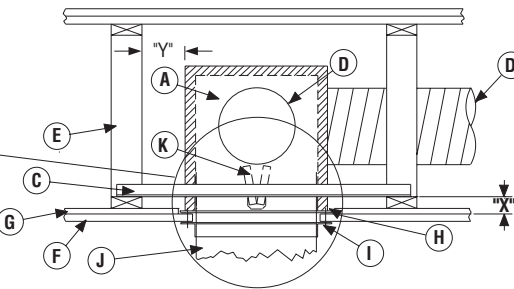

END VIEW WITH DUCT (0757D)

NOTES:

- Before installing, open damper blades and install fusible link between spring loaded wire clips. Do not bend or deform clips after assembly. If dampers are provided with link tabs instead of wire clips, install link and bend tabs to secure link in position.
- Attach 3/4" x 3/4" x 16 ga. (19 x 19 x 1.61) or 1 1/2" x 1 1/2" x 22 ga. (38 x 38 x 0.85) support angles to sub-frame with a minimum of two #8 screws or 3/16" (5) dia. steel pop rivets or spot welds each side. Distance from bottom of angle to bottom of plaster flange (X) should be the combined thickness of the wood truss member and the RC channel (See Detail A). **Make sure fasteners do not interfere with damper operation.**
- Install assembly between trusses as shown in End View and attach support angles to truss lower members using 1 1/4" (32) long type S steel screws or similar. See Detail C for alternate end view with duct (0757D). See Detail B for alternate support angle attachment method. Minimum clearance (Dimension "Y") between damper assembly and wood truss is 2" (51).
- Ceiling penetrations should be located between adjacent trusses and RC channels. If required, a maximum of one RC channel may be cut or notched to enable proper damper location. The clearance between the damper assembly and the cutout in the ceiling material shall be a maximum of 1/8" (3) on any side.
- Flex duct shall be UL Classified Air Duct Class 0 or Class 1 and shall be attached to the plenum collar with steel clamps, plastic straps, or minimum 18 gauge steel wire.
- Grille Mount Installation: The grille/diffuser frame shall be 26 ga. (0.55) minimum steel and shall be attached with a minimum of two #8 x 1 1/4" (32) min. screws through the ceiling material and into the plaster flange.
- Ducted Installation: Retaining angles shall be attached with a minimum of two #8 screws per side into the damper sleeve or into the plaster flange.
- Refer to UL Fire Resistance Directory Vol. I for details on UL Floor/Ceiling Design No.'s L528, L546, L550, L558, L562, L574, L576, L579, L581, L583, L585, M501, M503 and Roof/Ceiling Design No.'s P531, P533, P538, P545, P547, P552, 1 Hour Fire Rating.

Dimensions are in inches (mm).

SUPPLEMENTARY INSTALLATION INSTRUCTIONS

FABRICATION OF FIBERGLASS DUCTBOARD PLENUM

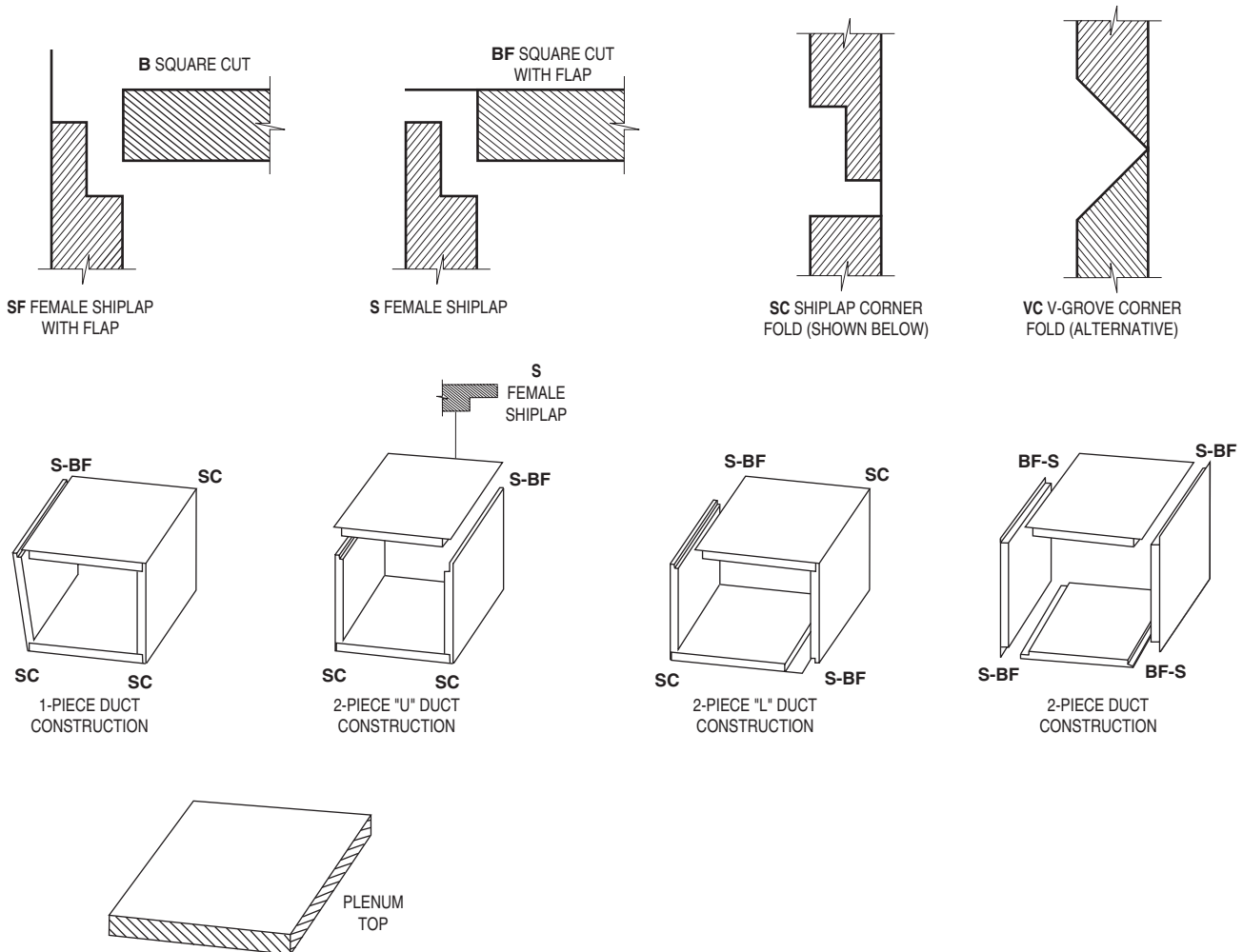

NOTES:

1. Fiberglass ductboard shall be UL 181 listed and have a density of 4 lbs. per cubic foot and a minimum thickness of 7/8" (22).
2. Edge and corner preparation shall be in accordance with details shown above. Plenum top shall be fabricated and attached using similar method, S-BF or BF-S.
3. Corner sealing tape shall be UL 181 listed and a minimum of 2" (51) wide.
4. Plenum shall be attached to the ceiling damper sub-frame using UL 181 listed tape.
5. Refer to page 1 of 6, for ceiling damper installation detail.
6. The 0757(D) Series ceiling Radiation Damper is classified for use in specific wood truss ceiling assemblies. See UL Fire Resistance Directory for Floor/Ceiling design No.'s L528, L546, L550, L558, L562, L574, L576, L579, L581, L583, L585, M501, M503 and Roof/Ceiling design No.'s P531, P533, P538, P545, P547, P552.

STEEL PLENUM:

- (A) Steel Plenum, (Register Boot/Box), by others, Min. 26 ga. (0.55) galvanized steel uninsulated
Min. 28 ga. (0.47) galvanized steel insulated
- (B) Steel frame Grille/Diffuser, 26 ga. (0.55) min., see note 6
- (C) 3/4" x 3/4" x 16 ga. (19 x 19 x 1.61) or 1 1/2" x 1 1/2" x 22 ga. (38 x 38 x 0.85) Support Angle (2 sides), see notes 2 & 3
- (D) Flex Duct UL Classified Air Duct (Class 0 or 1)
- (E) Wood Truss (refer to specific UL Design No.)
- (F) 5/8" (16) Gypsum Wallboard (refer to specific UL Design No.)
- (G) RC Channel
- (H) Plaster flange
- (I) 1" x 1" x 22 ga. (25 x 25 x .85) Retaining Angle (min.) on all 4 sides
- (J) Air Duct
- (K) Ceiling Damper (1 or 2 blades, or curtain type)

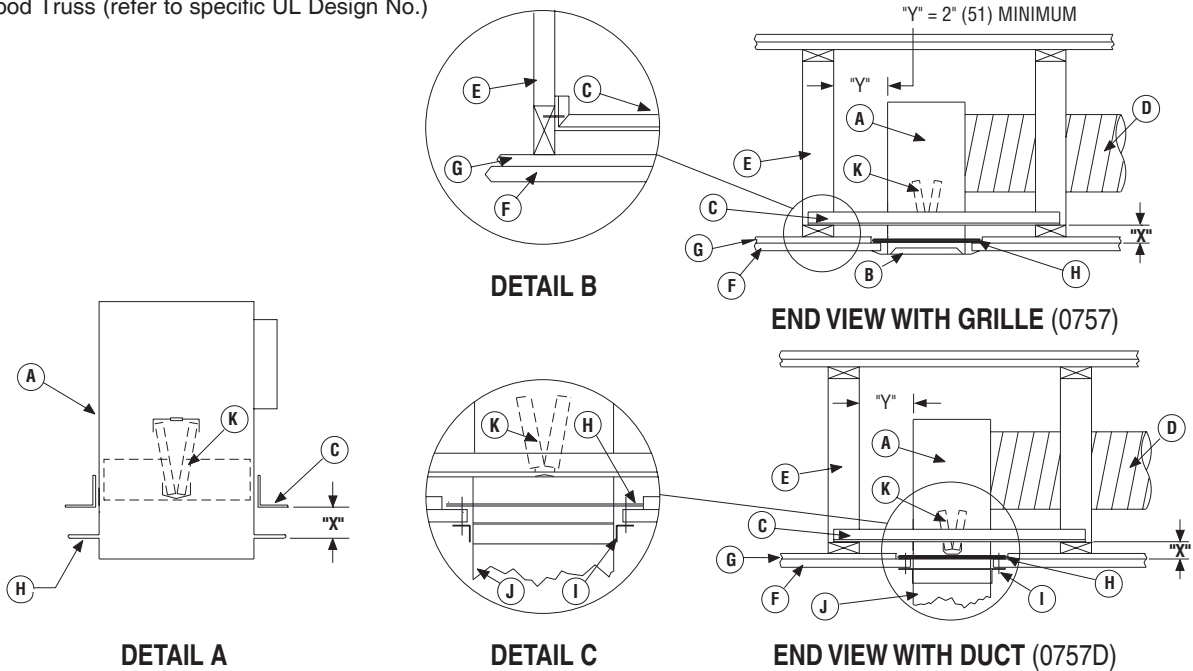

NOTES:

1. Before installing, open damper blades and install fusible link between spring loaded wire clips. Do not bend or deform clips after assembly. If dampers are provided with link tabs instead of wire clips, install link and bend tabs to secure link in position.
2. Attach 3/4" x 3/4" x 16 ga. (19 x 19 x 1.61) or 1 1/2" x 1 1/2" x 22 ga. (38 x 38 x 0.85) support angles to steel plenum with a minimum of two #8 screws or 3/16" (5) dia. steel pop rivets or spot welds each side. Distance from bottom of angle to bottom of plaster flange (X) should be the combined thickness of the wood truss member and the RC channel (See Detail A). **Make sure fasteners do not interfere with damper operation.**
3. Install assembly between trusses as shown in End View and attach support angles to truss lower members using 1 1/4" (32) long type S steel screws or similar. See Detail C for alternate end view with duct (0757D). See Detail B for alternate support angle attachment method. Minimum clearance (Dimension "Y") between damper assembly and wood truss is 2" (51).
4. Ceiling penetrations should be located between adjacent trusses and RC channels. If required, a maximum of one RC channel may be cut or notched to enable proper damper location. The clearance between the damper assembly and the cutout in the ceiling material shall be a maximum of 1/8" (3) on any side.
5. Flex duct shall be UL Classified Air Duct Class 0 or Class 1 and shall be attached to the plenum collar with steel clamps, plastic straps, or minimum 18 gauge steel wire.
6. Grille Mount Installation: The grille/diffuser frame shall be 26 ga. (0.55) minimum steel and shall be attached with a minimum of two #8 x 1 1/4" (32) min. screws through the ceiling material and into the plaster flange.
7. Ducted Installation: Retaining angles shall be attached with a minimum of two #8 screws per side into the damper sleeve or into the plaster flange.
8. The grille/diffuser frame shall be 26 gauge (0.55) minimum steel and shall be attached with a minimum of two #8 x 1 1/4" (32) min. screws through the ceiling material and into the plaster flange.
9. See table on page 4 of 6 for sizing details.
10. Refer to UL Fire Resistance Directory Vol. I for details on UL Floor/Ceiling Design No.'s L528, L546, L550, L558, L562, L574, L576, L579, L581, L583, L585, M501, M503 and Roof/Ceiling Design No.'s P531, P533, P538, P545, P547, P552, 1 Hour Fire Rating.

Dimensions are in inches (mm).

Page 3 of 6

SUPPLEMENTARY INSTALLATION INSTRUCTIONS

FABRICATION OF STEEL PLENUM

1 OR 2 BLADE STYLE DAMPERS:

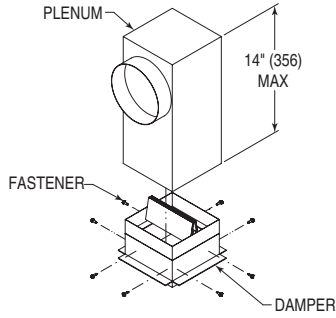

FIGURE 1A
MODEL 0757 - TYPE A PLENUM

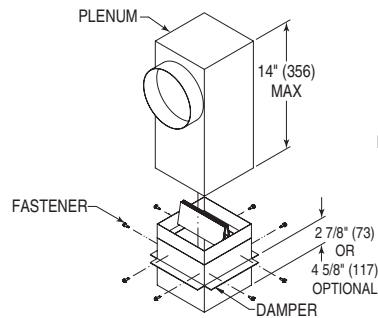
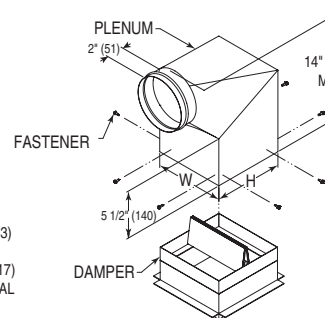
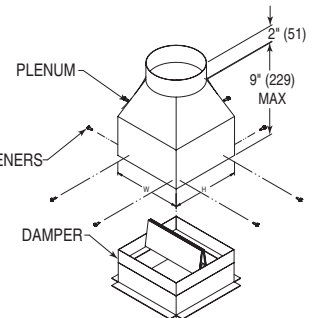

FIGURE 1B
MODEL 0757D - TYPE B PLENUM

ALTERNATE PLENUM DETAILS:



MODEL 0757 - TYPE D PLENUM



MODEL 0757 - TYPE E PLENUM

CURTAIN STYLE DAMPERS:

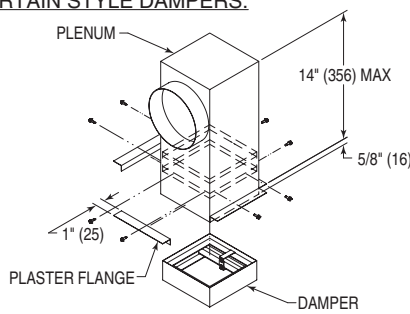

FIGURE 2A
MODEL 0757 - TYPE A PLENUM

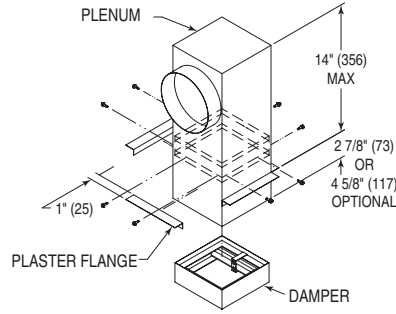

FIGURE 2B
MODEL 0757D - TYPE B PLENUM

INSULATED PLENUM DETAILS (DAMPER NOT SHOWN):

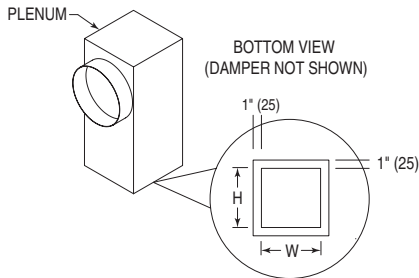
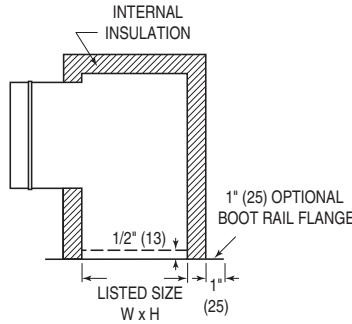

FIGURE 3
MODEL 0757 - TYPE C INSULATED PLENUM



Plenum Type	Description/ Installation	Min. Inside Plenum Dim.	Max. Damper Size	Max. Inside Plenum Dim.	Max. Inlet/Outlet Collar Size	Max. Number of Collars	Max. Overall Height
A	Grille Mount	6 x 4 (152 x 102)	16 x 12 (406 x 305)	16 x 12 (406 x 305)	10 (254) Dia.	5	14 (356)
B	Ducted	6 x 4 (152 x 102)	18 x 18 (457 x 457)	18 x 18 (457 x 457)	10 (254) Dia.	5	14 (356)
C	Insulated, 90° Side Inlet	8 x 4 (203 x 102)	12 x 12 (305 x 305)	12 x 12 (305 x 305)	10 (254) Dia.	1	14 (356)
D	Tapered, 90° Side Inlet	8 x 4 (203 x 102)	14 x 8 (356 x 203)	14 x 8 (356 x 203)	10 (254) Dia.	1	14 (356)
E	Tapered, Top Inlet	8 x 4 (203 x 102)	12 x 12 (305 x 305)	12 x 12 (305 x 305)	10 (254) Dia.	1	11 (279)

NOTES:

1. The steel plenum box and top shall be a minimum of 26 ga. (0.55) galvanized steel for uninsulated plenums, or minimum of 28 ga. (0.47) for insulated plenums, fastened together per SMACNA HVAC Duct Construction Standards, 4" (102) max. OC. In addition, the plenum top must be fastened 1" (25) max. from each side edge.
2. The inside dimensions (W x H) of the steel plenum shall be sized no greater than 1/8" (3) larger than the damper frame.
3. Duct outlet collars shall be round, oval, square, or rectangular, 78 1/2 sq. in. (50.6 sq. cm.) maximum per outlet per side with a maximum of 5 outlets with a combined area of 236 sq. in. (152 sq. cm.) for Plenum Type A or B, see chart above for alternate plenum type details. Outlet collars are not permitted on plenum box top for Type A or B plenums.
4. The damper is to be attached to the steel plenum box using steel rivets, spot welds, lock forms, or sheet metal screws 4" (102) max. OC, equally spaced around the circumference of the plenum box collar. Make sure fasteners do not interfere with damper operation.
5. For insulated plenums (Type C), attach the damper plaster flange to the bottom side of the plenum box, see Figure 3 above details. Fasten damper to plenum using self-piercing steel rivets, 4" (102) max. OC, equally spaced around the plenum box.
6. For insulated plenums (Type C), insulation shall be semi rigid Type R-6, 1 1/2" (28) or Type R-8, 2" (51) fiberglass duct liner, minimum density 1.5 pcf. Insulation is self-supporting within plenum box. All internal surfaces must be lined with insulation, excluding outlet collar. The bottom edge of the insulation is trapped by a lip that is formed on the plenum box that extends a min. of 1" (25) from the inner edge of the opening to the outer edge of the box and extends a min. of 1/2" (13) up into the opening. See detail above.
7. Optionally, Plenum Types D & E can also be insulated per requirements in note 5 & 6.
8. For curtain style ceiling dampers, a 1" x 1" x 22 ga. (25 x 25 x 0.85) min. plaster flange is secured to the plenum box using spot welds, self-piercing steel rivets, or sheet metal screws, spaced max. 6" (152) max. OC, 2" (51) from each corner (See Figure 2A or 2B).
9. Refer to page 3 of 6, document IOM-CRD0757INST for ceiling damper installation detail.
10. The 0757(D) Series Ceiling Radiation Damper is classified for use in specific wood truss ceiling assemblies. See UL Fire Resistance Directory for Floor/Ceiling design No.'s L528, L546, L550, L558, L562, L574, L576, L579, L581, L583, L585, M501, M503 and Roof/Ceiling design No.'s P531, P533, P538, P545, P547, P552.



Houston, Texas
Tel: 281-590-1172
Fax: 281-590-3086

Las Vegas, Nevada
Tel: 702-648-5400
Fax: 702-638-0400

Toronto, Canada
Tel: 416-744-3300
Fax: 416-744-3360

Calgary, Canada
Tel: 403-279-8619
Fax: 403-279-5035