

DESCRIPTION:

1. Pull ring: 1 1/4 (32) diameter nickel plated steel.
2. Attachment strap: 22 ga. galvanized or stainless steel.

Horizontal curtain type fire dampers for use in static systems and all dynamic dampers utilize stainless steel springs and locking ramps to draw the curtain closed in the event of a fire or upon manual release.

Horizontally installed dampers are designed and tested to be mounted with the locking ramps on the top side. When periodic testing (as well as maintenance and inspection) is required, access doors should be located above the damper, so that the damper blade pack can be "pushed down" and released off the locking ramp for reset.

When access from above is not possible or convenient, the Pull-Tab release option permits simple resetting from beneath the damper.



TOP OF UNIT (Horizontal Installation)

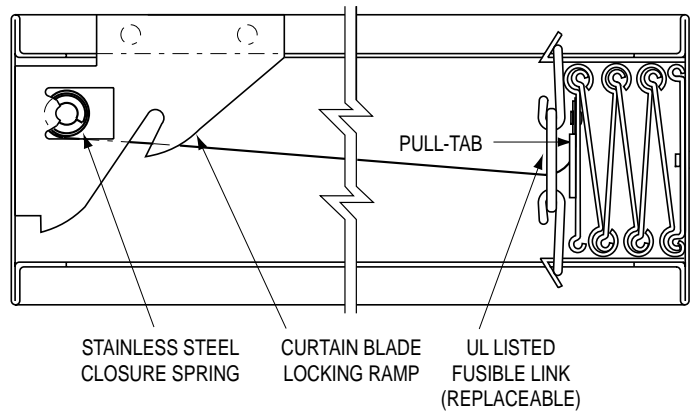

TYPE "A" MODEL 0110H (TYPE "B" SIMILAR).

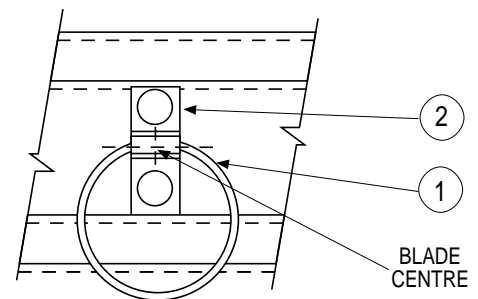
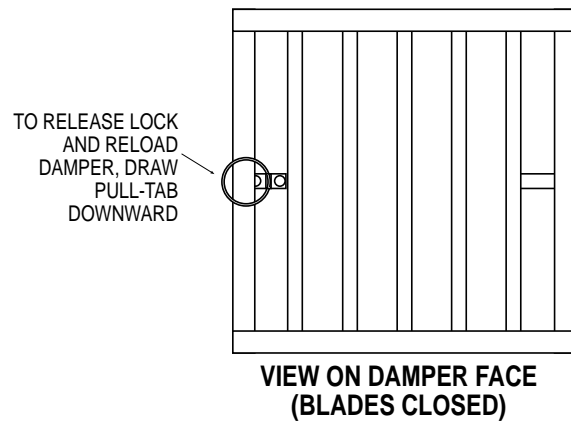

DETAIL OF PULL-TAB

Dimensions are in inches (mm).



Houston, Texas
Tel: 281-590-1172
Fax: 281-590-3086

Ft. Lauderdale, Florida
Tel: 954-351-2444
Fax: 954-351-2440

Toronto, Canada
Tel: 416-744-3300
Fax: 416-744-3360

Calgary, Canada
Tel: 403-279-8619
Fax: 403-279-5035