

APPLICATION:

Fire dampers are UL/ULC Classified for their maximum size or maximum assembly size. Generic steel mullions can be used in static HVAC systems to separate vertically mounted 1 1/2 hour labeled galvanized steel fire dampers in vertical wall openings larger than maximum UL/ULC permitted multiple damper assembly size. Fire dampers must not exceed a maximum 120" (3048) height by unlimited width using vertical mullions every 120" (3048) max. Mullions are not intended to be part of the ductwork. (i.e. exposed to airflow).

Whenever the duct size exceeds the maximum damper width or height, the opening must be divided into two or more separate openings with a mullion installed between the damper sections. The mullion consists of a vertical and/or horizontal mullion and mullion caps. One cap for each end of the mullion.

The steel mullion is intended for use only in concrete block or poured walls with 7" (178) minimum and 12" (305) maximum thickness. Hollow concrete block walls are to be suitably filled with minimum 3500 psi concrete for proper securing of mullions.

Important Note: Steel mullions are for use in static systems only. UL/ULC does not acknowledge their use with dynamic fire dampers.

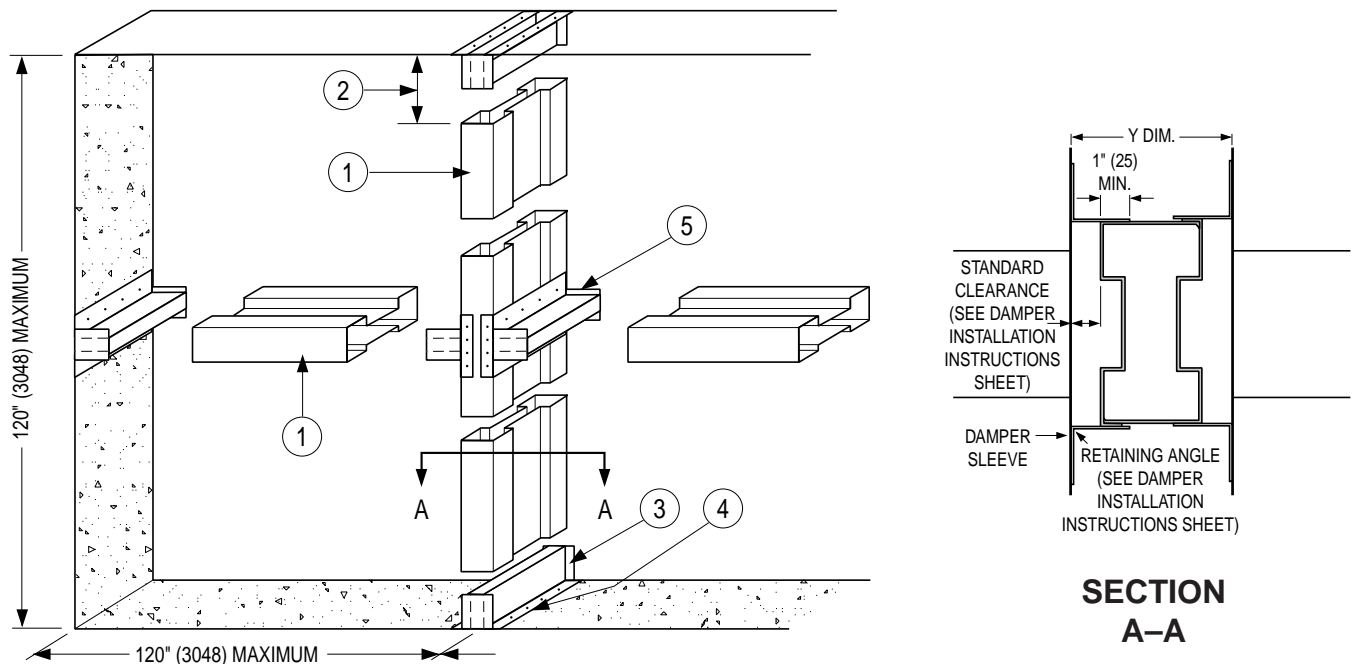

FABRICATION AND GENERAL INSTALLATION:

1. Fabricate mullions of 16 ga. (1.6) galvanized steel as shown in **Figure 1**. Two mullion pieces are joined with 3/16" (5) diameter steel pop rivets or 3/4" (19) long welds located 6" (152) maximum from each end and 12" (305) O.C. maximum.
2. The mullion should permit clearance between the mullion and top cap. Required clearance is 1/8" (3) per foot of wall opening height. Minimum permitted clearance is 1/4" (6). Maximum permitted clearance is 1 1/4" (32) (e.g. for an 8 ft. (2438) high opening the permitted clearance is 1/8" (3) x 8 = 1" (25) +).
3. Fabricate two caps for each mullion of 12 ga. (2.8) galvanized steel as shown in **Figure 2** for vertical and horizontal mullions. (Caps must permit mullion to overlap each cap by minimum 3" (76)). Cap height is calculated by adding 3" (76) to permitted mullion expansion clearance which is 1/8" (3) per foot of wall opening height. Insert mullion caps into mullion ends allowing mullion to float between the caps. Do not fasten mullion to caps in any way. Locate within opening to provide correct expansion clearance for dampers.
4. Drill holes in caps and concrete for anchoring steel mullion caps with 1/4" (6) – 20 x 5/16" (8) steel screws and 3/8" (10) diameter x 1" (25) concrete expansion anchors. The eight holes to secure the cap (**Figure 3**) are equally spaced, X ÷ 8 from both ends and 1/2" (13) inwards of each side.
5. Set horizontal mullion caps at vertical mullions as shown (**Figure 4**). If steel lintels are present, four 1" (25) welds (two per mullion cap leg) may be used to anchor each mullion cap.

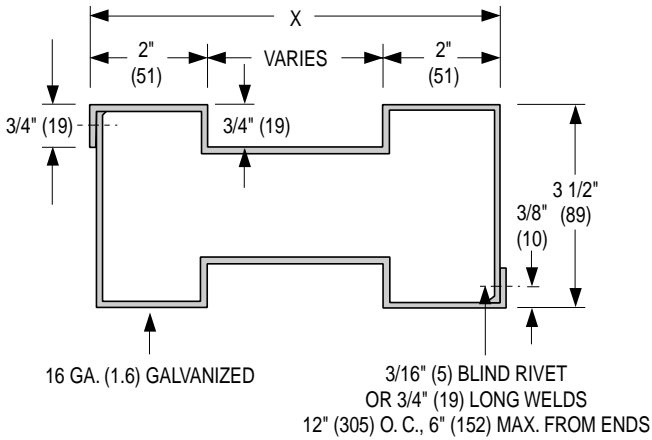

FIGURE 1
MULLION CROSS-SECTION

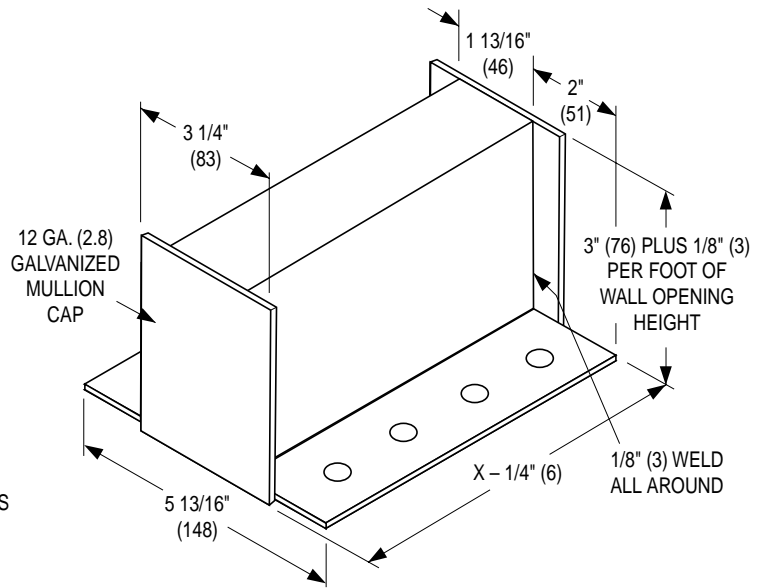

FIGURE 2

X = WALL THICKNESS

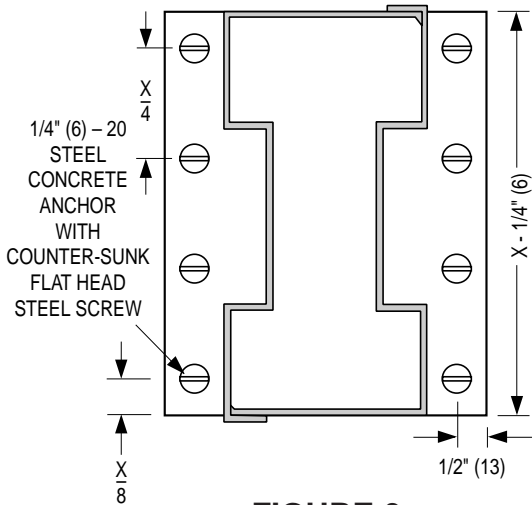

FIGURE 3

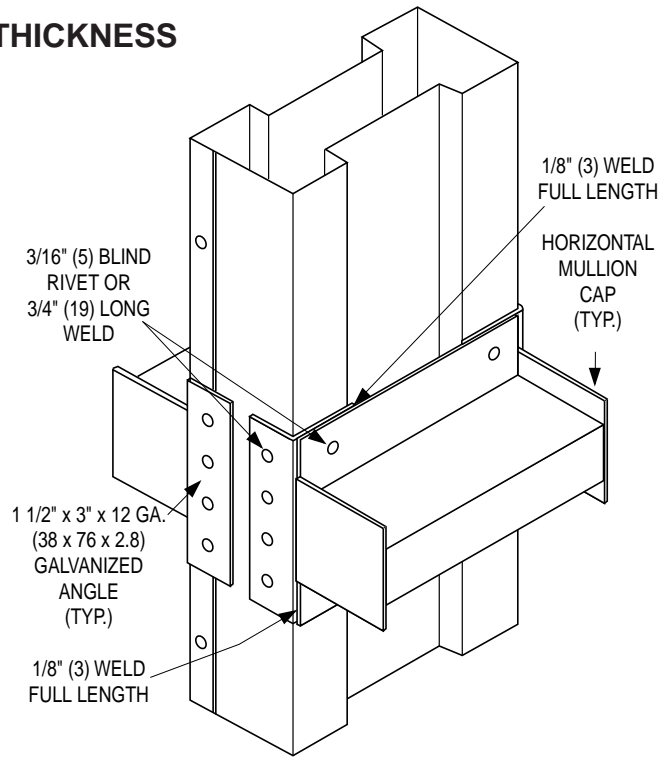

FIGURE 4



Refer to the UL or ULC Classification Marking on the Product

These instructions comply with Underwriters Laboratories Safety Standard 555.

Dimensions are in inches (mm).

Page 2 of 2



Houston, Texas
Tel: 281-590-1172
Fax: 281-590-3086

Las Vegas, Nevada
Tel: 702-648-5400
Fax: 702-638-0400

Toronto, Canada
Tel: 416-744-3300
Fax: 416-744-3360

Calgary, Canada
Tel: 403-279-8619
Fax: 403-279-5035