

Application and Operation

The Nailor PRL Pneumatic Replaceable Link is a UL Classified heat responsive device used in conjunction with Nailor combination fire/smoke dampers.

The PRL is supplied as standard on all combination fire/smoke dampers ordered with a pneumatic actuator. An alternative to the PRL would be the Nailor ERL (Electric Resettable Link) with an EP (Electric/Pneumatic) Switch.

The PRL is a factory mounted pneumatic release valve/replaceable fusible link assembly. The PRL's function is to sense an abnormally high temperature, as caused by a fire, and allow the damper to close in order to prevent the spread of fire and smoke.

Fire Control Mode: The PRL activates when fire temperatures in excess of 165, 212 or 280°F (74, 100 or 138°C) are detected. When the fusible link melts, air from the pneumatic actuator(s) is exhausted and the actuator spring return mechanism causes the damper to close and lock.

Smoke Control Mode: When a signal is detected via a normally closed smoke detector connection, during system testing or if power failure occurs, the damper will close and remain closed. When the smoke signal ceases (smoke detector reset), the test is completed or power is restored, the damper will automatically reset to the open position.

An EP (Electric/Pneumatic) Switch, by others, must be present in the system.

All pneumatic actuators are factory mounted with a fail close (Normally Closed) damper connection.

Notes:

1. The PRL must be installed at the factory and cannot be added in the field, in accordance with UL requirements.
2. A single PRL may be used to control up to a maximum of four pneumatic actuators.
3. Pneumatic actuators are to be field piped per local codes.

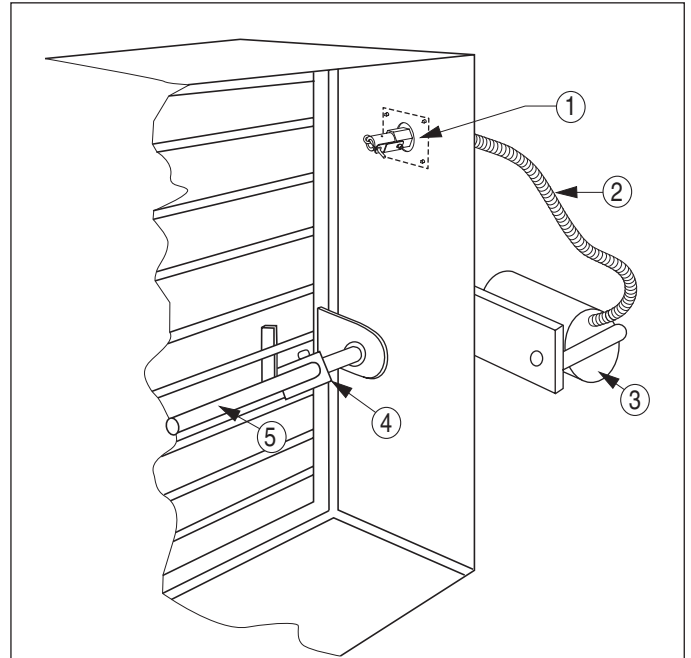

Typical Combination Fire/Smoke Damper Detail with UL Listed Pneumatic Actuator Description:

1. PRL 165, 212 or 280°F Pneumatic Replaceable Link
2. Silicone Tubing
3. Pneumatic Actuator
4. Over-center Knee Lock
5. Jackshaft

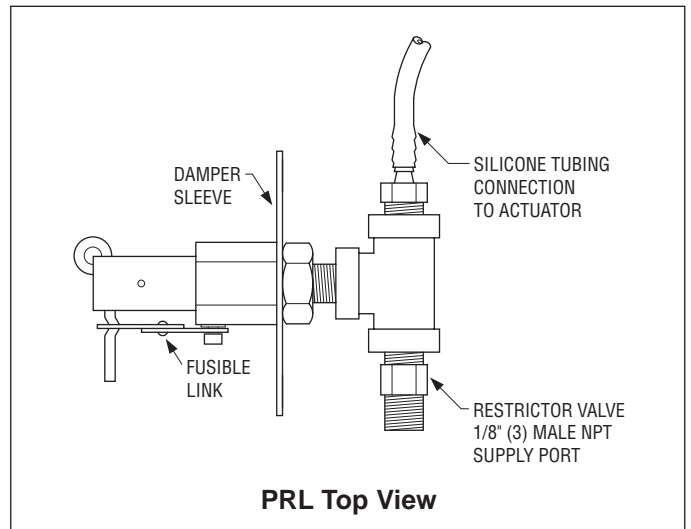



Houston, Texas
Tel: 281-590-1172
Fax: 281-590-3086

Las Vegas, Nevada
Tel: 702-648-5400
Fax: 702-638-0400

Toronto, Canada
Tel: 416-744-3300
Fax: 416-744-3360

Calgary, Canada
Tel: 403-279-8619
Fax: 403-279-5035