

Model Series: 1210, 1260, 1280 Multi-Blade Damper

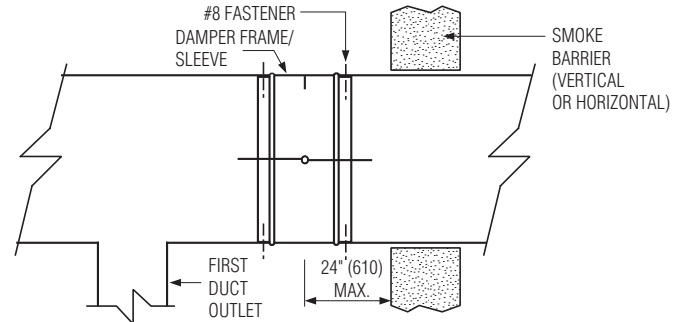

Models: 1290S or 1290S-SS Round Damper

NOTES:

- 1. Installation and Location Requirements:** Smoke dampers are required where building codes require a leakage rated damper as part of a static or dynamic smoke management system. Installation shall be in accordance with the appropriate requirements of the National Fire Protection Association Bulletin NFPA 90A latest edition. Dampers are to be installed at or adjacent to the point where the duct passes through the smoke barrier unless the damper is used to isolate equipment. Dampers are designed to operate with blades running horizontally (except Model 1210VB). The damper must be installed with plane of the closed damper blades a maximum of 24" (610) from the smoke barrier and before any duct inlets or outlet.
Damper must be installed square, plumb, and free from racking to ensure optimum performance and correct operation.
- 2. Damper to Sleeve/Duct Attachment:** Damper shall be secured to sleeve or duct with 1/4" (6) long welds, 3/16" (5) dia. steel rivets, 1/4" (6) dia. bolts and nuts, #8 sheet metal screws, 3/16" (5) dia. buttonloks on both sides, at 6" (152) on center and a maximum of 4" (102) from the corners of the damper on all four sides. All joints between the damper and the sleeve or duct and between dampers in multiple sections, shall be sealed with Dow-Corning 732, G.E. 108 or Boss Type 310 or 315 RTV silicone sealant on one side only.
- 3. Actuators and Accessories:** Smoke dampers and qualified actuators are tested together by UL and are factory installed to qualify for damper/actuator standard warranties. Factory installed electric actuators may be 24, 120 or 230 VAC. Connect the incoming L1 and L2 power leads to the proper motor terminals, or, if no terminals are available, directly to the motor leads. All wiring must be in accordance with the applicable electrical codes and NFPA 70. Factory installed pneumatic actuators are rated at a pressure of 25 PSI. The pneumatic actuator shall be connected to the air supply thru metallic tubing. A short silicone tubing pigtail is acceptable. If MLS-300 position indicators are used, refer to the proper installation instructions for the MLS-300.
- 4. Maximum Size Limitations:**
 1. A rectangular damper assembly must not exceed the single section sizes and assembly sizes shown below.
 2. In multiple assemblies of vertical or horizontal dampers, the frames shall be joined together on both sides of the damper using 1/4" (6) long welds, 1/4" (6) dia. bolts and nuts or #8 sheet metal screws. Center distances are as noted in the joint details (Figure 1) shown below.
 3. In addition, on multiple section assemblies with extended velocity ratings, greater than 2000 fpm (10.2 m/s), #14 screws, 1/4" (6) dia. bolts and nuts, or 1/4" (6) long welds shall be used for all damper to damper joints where four damper sections adjoin and shall be located within 1" (25) of each mating corner of each damper section. Fastener/welds required on both sides of the damper assembly. (See Figure 2).

Damper Model Series	Maximum Single Section Size Dampers	Maximum Multiple Section Assembly
1210, 1280	36" x 48" (914 x 1219)	144" x 96" or 288" x 48" (3658 x 2438 or 7315 x 1219)
1260	36" x 48" (914 x 1219)	144" x 48" or 36" x 96" (3658 x 1219 or 914 x 2438)
1210M	36" x 48" (914 x 1219)	144" x 96" (3658 x 2438), 288" x 48" (7315 x 1219)
1210BAL	36" x 48" (914 x 1219)	N/A
1210VB	48" x 36" (1219 x 914)	N/A
1290S	24" (610) dia.	N/A
1290S-SS	24" (610) dia.	N/A

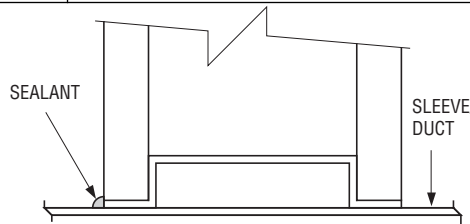

DAMPER FRAME TO SLEEVE ATTACHMENT
(SEE NOTE 2)

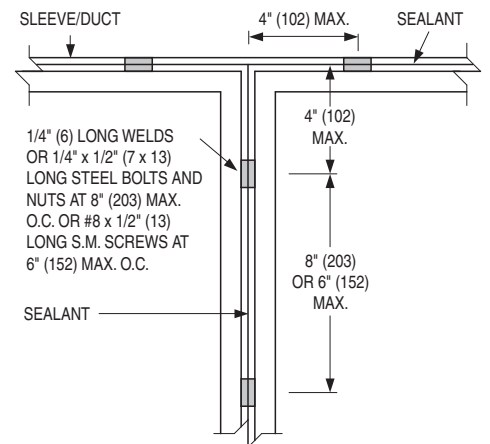

FIGURE 1: JOINT DETAILS FOR LEG OUT FRAME
Dimensions are in inches (mm).

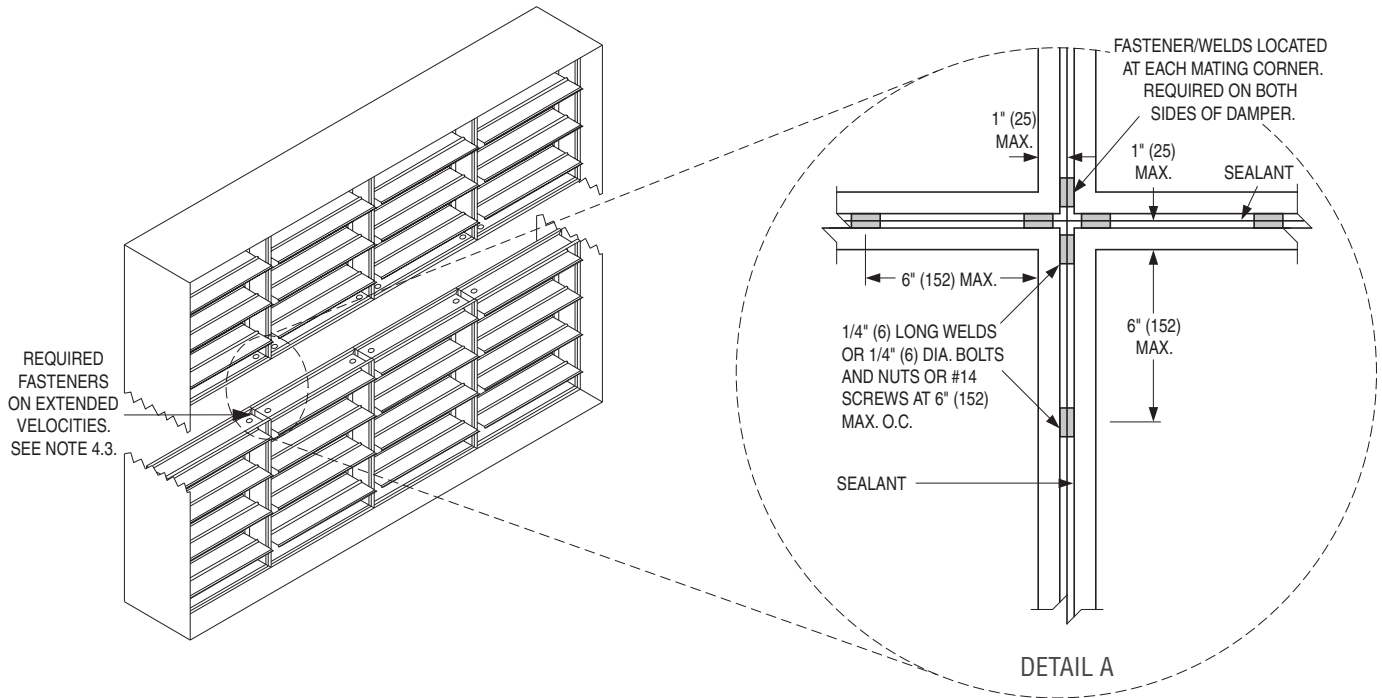

FIGURE 2: JOINT DETAILS FOR MULTIPLE SECTION ASSEMBLIES WITH EXTENDED VELOCITIES