



FLOOR "SWIRL" DIFFUSER
FIXED DISCHARGE PATTERN • ROUND
UNDERFLOOR AIR DISTRIBUTION SYSTEMS
MODEL: NFD

DESCRIPTION:

The Nailor NFD floor diffuser is designed for use in raised access floor air distribution systems, where the floor cavity is used as a pressurized supply air plenum. The NFD core design produces a low velocity helical "swirl" discharge air pattern. This design achieves high induction rates of room air which optimizes mixing for maximum comfort conditions.

FEATURES:

- Constructed of high impact polycarbonate plastic complying with UL Standard 94-5V for flammability.
- Nominal size 8" (203) dia. Low profile design.
- Dust/dirt collection basket catches anything that might fall through diffuser face. Removable for cleaning.
- Optional flow regulator damper adjustable without removing the diffuser core, features visual open/ closed indication and includes an adjustable minimum volume stop.
- Low pressure drop core/damper assembly design.
- Core lies flush with trim ring flange, with or without damper.
- Rugged trim ring design secures carpet and prevents edges from fraying.
- Unique adjustable mounting clamp design adapts to any floor panel thickness and provides simple and secure installation. Permits installation from above the floor without removal of the floor panel or carpet.
- A PVC ribbed Press Fit Gasket is also available as a "labor saving" mounting option.
- Optional underfloor mounting ring available.
- Standard finish is GR Gray or BK Black core and trim ring. Damper/basket are black.

SELECTION:

1. TR Trim Ring (standard)
 None
2. Dirt Basket/Damper
 BDA Attached to Core (standard)
 BDL Loose
 BOO Basket Only
 None
3. Mounting (requires trim ring):
 MC Mounting Clamps (standard)
 PFG Press Fit Gasket (optional)
 MR Mounting Ring (optional)
4. Finish:
 GR Gray
 BK Black
 SP Special (custom color by architect)
 Specify _____.
5. Accessories:
 CLC Core Locking Clips
 BDEX Basket/Damper Extension
 (see submittal NFD-BDEX)

HOLE OPENING DIAMETER

MC Mounting Clamps = 8 1/4" (210).
 PFG Press Fit Gasket = 8 3/8" (213) +/- 1/32" (0.8).

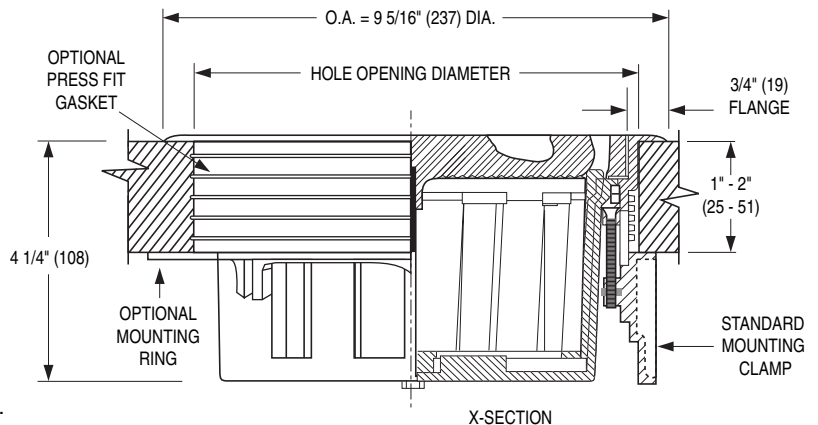
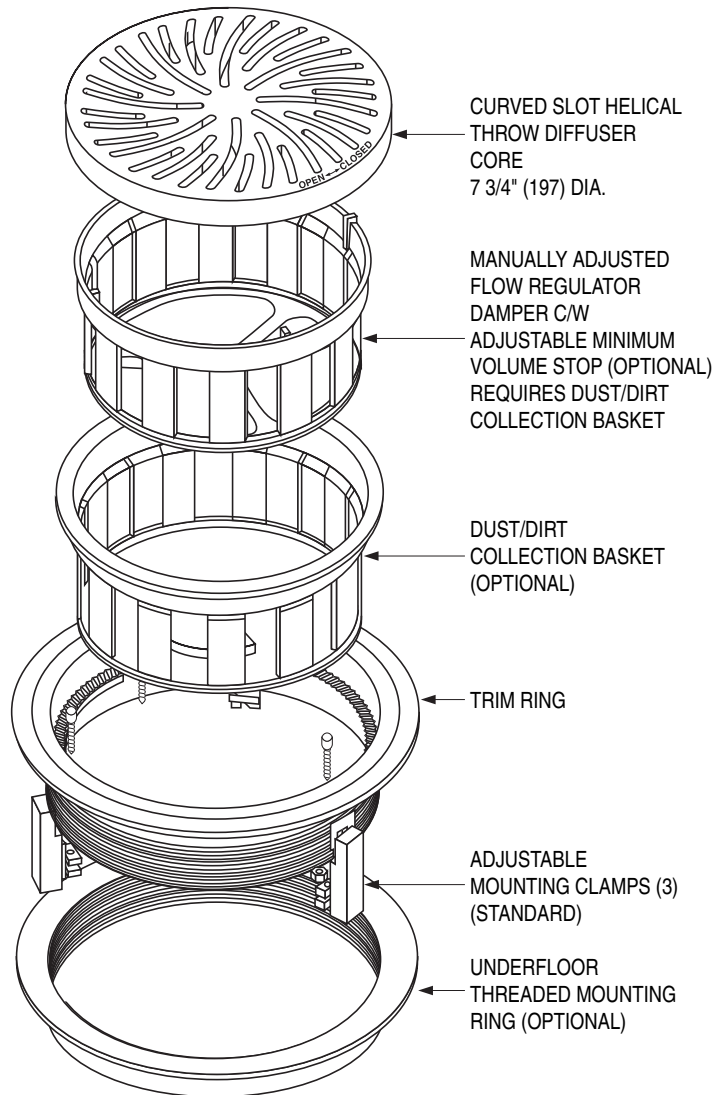

Dimensions are in inches (mm).

SCHEDULE TYPE:					
PROJECT:					
ENGINEER:		DATE	B SERIES	SUPERSEDES	DRAWING NO.
CONTRACTOR:		2 - 28 - 11	NFD	6 - 26 - 09	NFD-1