



VAV FLOOR "SWIRL" DIFFUSER WITH ACTUATOR
UNDERFLOOR AIR DISTRIBUTION SYSTEMS
VAV • COOLING ONLY
MODEL: NFD-VAV

DESCRIPTION:

The Nailor NFD-VAV floor diffuser with actuator is designed for use in raised access floor air distribution systems, where the floor cavity is used as a pressurized supply air plenum. An integral modulating actuator provides variable air volume control in cooling applications for precise zone temperature control. The NFD-VAV core design produces a low velocity helical "swirl" discharge air pattern. The design achieves high induction rates of room air which optimizes mixing for maximum comfort conditions.

FEATURES:

- Constructed of high impact polycarbonate plastic complying with UL Standard 94-5V for flammability.
- Nominal size 8" (203) dia. Low profile design.
- Dust/dirt collection basket catches anything that might fall through diffuser face. Removable for cleaning.
- Variable volume flow regulator damper, features visual open/closed indication and includes built in end stops.
- Compact 24 VAC direct drive proportional actuator.
- Minimum and maximum airflow limits are achieved by limiting the range of the control signal.
- Actuator features two RJ12 ports for simple interconnection using modular plenum rated cables. Multiple units can be 'daisy-chained' together.
- Optional thermostat, thermostat cable and power supply modules are available (see next page).
- Architecturally pleasing face design compliments contemporary decor and lies flush with trim ring flange.
- Rugged trim ring design secures carpet and prevents edges from fraying.
- Unique adjustable mounting clamp design adapts to any floor panel thickness and provides simple and secure installation. Permits installation from above the floor without removal of the floor panel or carpet.
- Optional underfloor mounting ring available.
- A PVC ribbed Press Fit Gasket is also available as a "labor saving" mounting option.
- Standard finish is GR Gray or BK Black core and trim ring. Damper/basket are black.

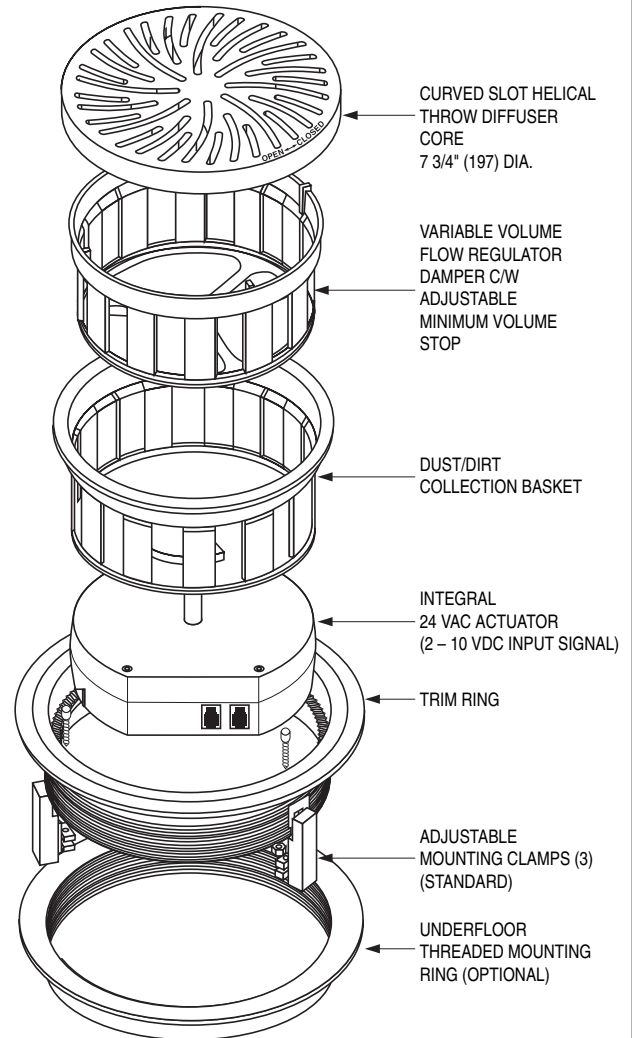

SELECTION:

1. Mounting:
 - MC Mounting Clamps (standard)
 - PFG Press Fit Gasket (optional)
 - MR Mounting Ring (optional)
2. Actuator Cable:
 - 12 12 ft. long (standard)
 - 20 20 ft. long (optional)
3. Finish:
 - GR Gray
 - BK Black
 - SP Special (custom color by architect)
Specify _____ .
4. Special Features:
 - _____ .

HOLE OPENING DIAMETER

MC Mounting Clamps = 8 1/4" (210).
 PFG Press Fit Gasket = 8 3/8" (213) +/- 1/32" (0.8).

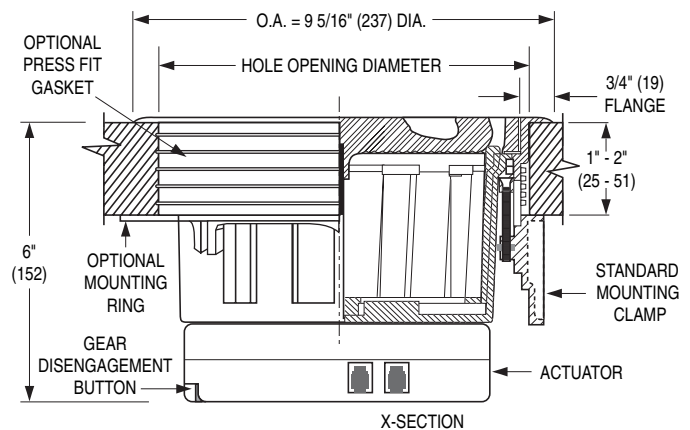

SCHEDULE TYPE:		Page 1 of 2			
PROJECT:		Dimensions are in inches (mm).			
ENGINEER:	DATE	B SERIES	SUPERSEDES	DRAWING NO.	
CONTRACTOR:	6 - 26 - 09	NFD	5 - 15 - 09	NFD-VAV-1	

VAV FLOOR "SWIRL" DIFFUSER CONTROL DIAGRAM

UNDERFLOOR AIR DISTRIBUTION SYSTEMS

VAV • COOLING ONLY

MODEL: NFD-VAV

DESCRIPTION:

The Nailor NFD-VAV floor diffuser is designed to provide VAV control in cooling applications. Advanced micro-computer electronics and P+I control algorithms provide precise temperature control.

CONTROL FEATURES:

- Fast connection/wiring between units with RJ12 (phone jack) connections. Allows units to be quickly installed or relocated.
- Compact direct-drive 24 VAC actuator utilizes a 2 – 10 VDC control signal for precise airflow control.
- Standard 12 ft. modular plenum rated cables, for interconnection between diffusers, allows diffusers to be spaced on 10 ft. intervals (20 ft. cables optional).
- Power supply modules allow connection of up to 12 units on each line voltage connection (6 diffusers on each side) (8 units total or 4 on each side with optional 20 ft. cables).
- Each thermostat can control a maximum of 3 power supplies.
- Minimum and maximum airflow limits are adjusted underneath the thermostat cover.

ACCESSORIES:

1. Thermostat
 - NCTE-5015-10 °F Scale
 - NCTE-5015-11 °C Scale
2. Cables:
 - NHSO-5012 50 ft. Thermostat Cable
3. Power Supply Module (includes NHSO-5011 transformer cable, NHSO-5010 3-way connector and transformer mounted & wired in a sheetmetal enclosure):
 - NPS-120 120 Volt Supply Voltage
 - NPS-277 277 Volt Supply Voltage
 - NPS-240 240 Volt Supply Voltage
 - NPS-480 480 Volt Supply Voltage
4. Special Features: _____ .

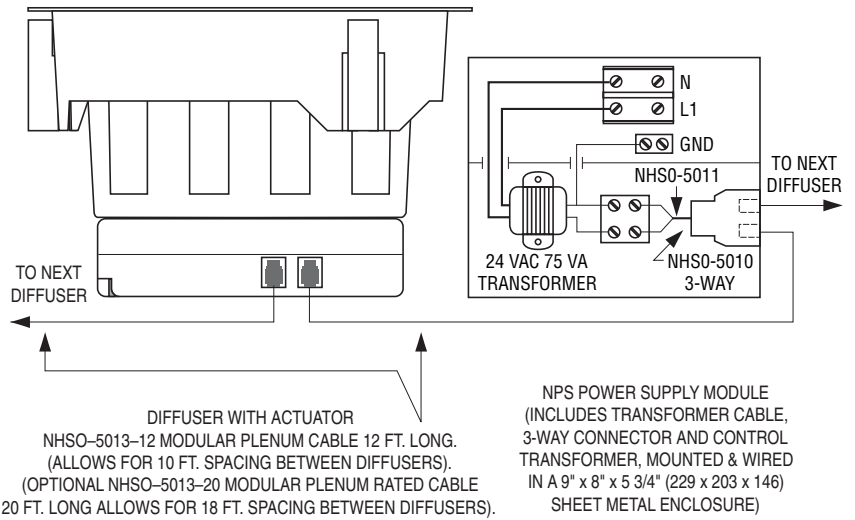

DETAIL A

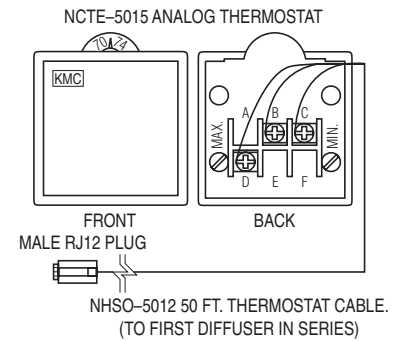

DETAIL B

SYSTEM OVERVIEW (SIDE VIEW):

A maximum of six actuators can be daisy chained on each side of a power supply module (4 actuators with optional 20 ft. cables). This allows a maximum of twelve actuators per power supply (8 actuators total with optional 20 ft. cables). Each thermostat can handle up to three power supply/actuator sub-systems for a total of up to thirty-six diffusers per thermostat, (24 diffusers with optional 20 ft. cables).

CONNECTION TO DDC CONTROLS:

The standard thermostat provides a direct acting 2 – 10 VDC control signal (Terminal D) to the actuator (Terminal B is Common). These wires can be connected to another signal source for control by the BMS. A 10 VDC signal will drive the damper fully open to provide maximum airflow. Similarly a 2 VDC signal (or less) will drive the damper fully closed.

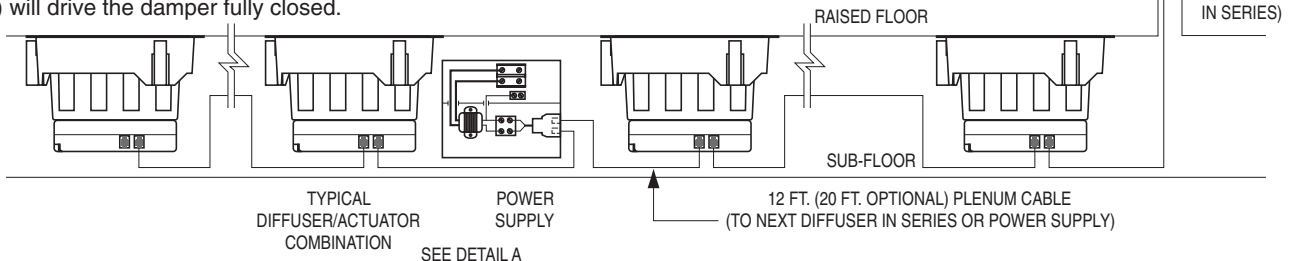

SCHEDULE TYPE:

PROJECT:

ENGINEER:

CONTRACTOR:

Page 2 of 2
Dimensions are in inches (mm).

DATE	B SERIES	SUPERSEDES	DRAWING NO.
6 - 26 - 09	NFD	5 - 15 - 09	NFD-VAV-1