

**DESCRIPTION:**

The Nailor NLD Linear Floor Diffusers are designed for use in raised access floor air distribution systems. High quality, heavy duty, extruded aluminum linear grilles are featured providing an architecturally appealing face design that compliments contemporary decor. Heavy gauge steel plenums incorporate a large dust/dirt collection area that catches anything that might fall through the diffuser face.

Model NLD-C provides constant volume control for non-ducted (pressurized access floor) applications. An integral opposed blade damper provides precise airflow control.

**FEATURES:**

- Simple installation, unit fits into place from the top (room side) of the floor panel.
- 12" (305) overall height allows installation in 12" (305) raised access floors.
- Five available heavy duty core styles to choose from (see following page).
- All heavy duty cores are removable and supplied with core clips as standard.
- Two available frame options (Frame F or H).
- Standard fastening is Type B friction spring clips.
- Opposed blade damper features a gang operated multi-blade design with blades closing at 45 degrees. This ensures fine volume control for accurate balancing with minimum disturbance to the airflow pattern.
- Optional Type DV directional vanes provide an adjustable discharge pattern to enhance coverage of perimeter windows and reduce throw.
- Optional BKP black painted finish on interior plenum surfaces.
- Standard finish is AW Appliance White.

**SELECTION:**

Core Selection:

- 240 - 1/4" (6) Bars - 1/2" (13) Spacing - 0° Def.
- 241 - 1/4" (6) Bars - 1/2" (13) Spacing - 15° Def.
- 243 - 1/4" (6) Bars - 1/2" (13) Spacing - 30° Def.
- 480 - 1/8" (3) Bars - 1/4" (6) Spacing - 0° Def.
- 481 - 1/8" (3) Bars - 1/4" (6) Spacing - 15° Def.

Frame Type:

- Type F 1" (25) Heavy Duty Flange
- Type H 3/4" (19) Heavy Duty Flange

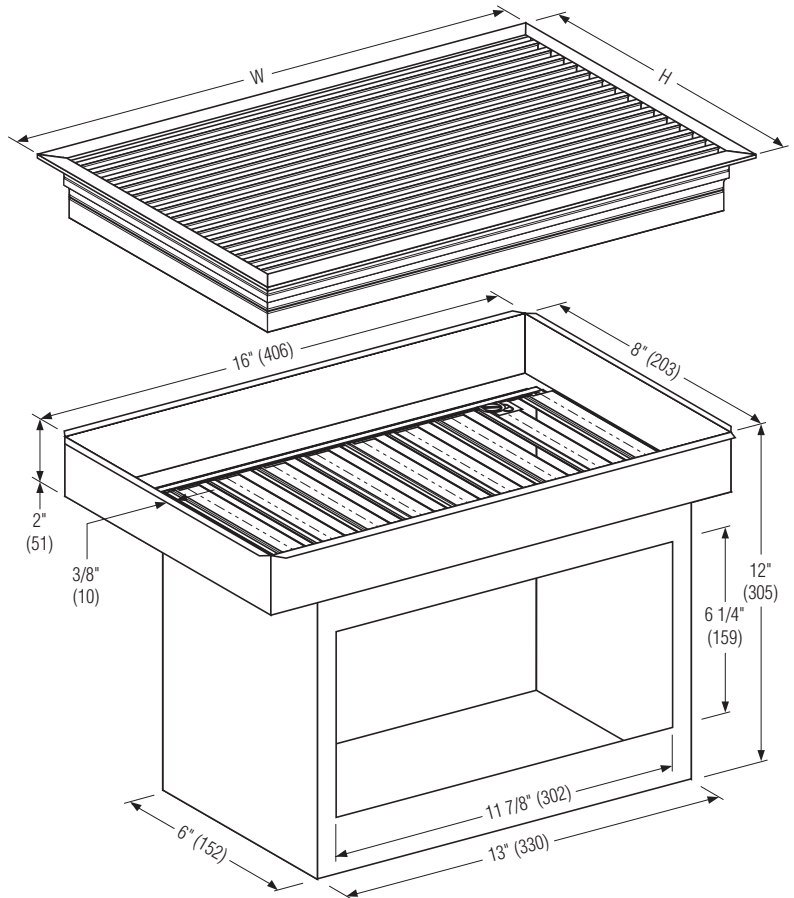

FLOOR OPENING = 16 1/4" x 8 1/4" (413 x 210)  
W = 17 5/8" (448) FOR FRAME F OR 17 1/8" (435) FOR FRAME H  
H = 9 5/8" (244) FOR FRAME F OR 9 1/8" (232) FOR FRAME H

Fastening:

- Type B Friction Spring Clip (standard)
- Type A Countersunk Screw Holes (frame F only)

Finish:

- AW Appliance White (default)
- GRT Gray (textured)
- BKT Black (textured)
- AL Aluminum
- SA Satin (Clear) Anodized
- BC Brushed clear-coat lacquer
- MI Mill
- BK Black
- SP Special. Specify \_\_\_\_\_ .

**OPTIONS:**

- DV Directional Vanes
- BKP Plenum Interior Painted Black

<b>SCHEDULE TYPE:</b>		Page 1 of 2			
<b>PROJECT:</b>		Dimensions are in inches (mm).			
<b>ENGINEER:</b>	<b>DATE</b>	<b>B SERIES</b>	<b>SUPERSEDES</b>	<b>DRAWING NO.</b>	
<b>CONTRACTOR:</b>	8 - 23 - 06	NLD	9 - 7 - 05	NLD-C	

**1. CORE SELECTION:**

- 480 - 1/8" (3) Bars - 1/4" (6) Spacing  
 - 0° Deflection (Standard)

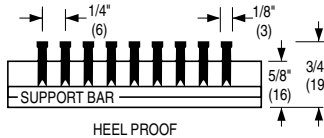

- 481 - 1/8" (3) Bars - 1/4" (6) Spacing  
 - 15° Deflection

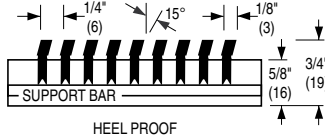

- 240 - 1/4" (6) Bars - 1/2" (13) Spacing  
 - 0° Deflection

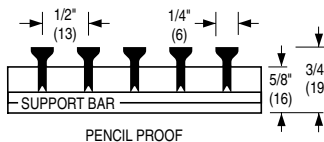

- 241 - 1/4" (6) Bars - 1/2" (13) Spacing  
 - 15° Deflection

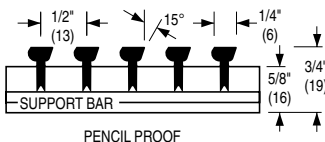

- 243 - 1/4" (6) Bars - 1/2" (13) Spacing  
 - 30° Deflection

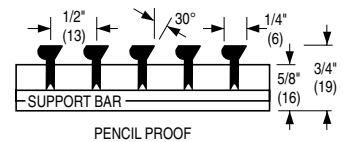

**2. FRAME SELECTION:**

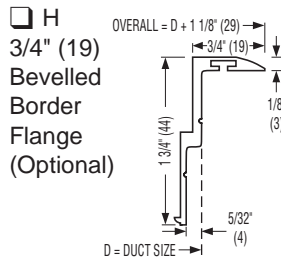
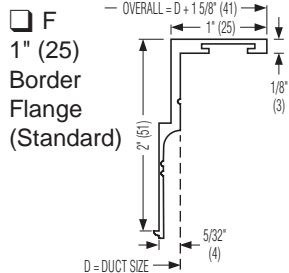

**3. FASTENING SELECTION:**

- TYPE B  
 Spring Clip  
 (Frames F or H)  
 (Standard)

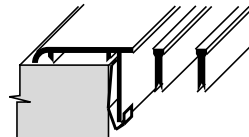

- TYPE A  
 #8 Countersunk Screw  
 Holes. (Frame F only)  
 (Optional)

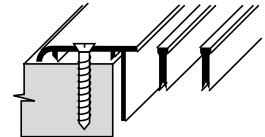

**4. FINISH SELECTION:**

- AW Appliance White (Standard)
- GRT Gray (textured)
- BKT Black (textured)
- AL Aluminum
- SA Satin (clear) Anodized
- BC Brushed clear-coat lacquer
- MI Mill
- BK Black
- SP Special \_\_\_\_\_

**5. OPTIONS:**

- DV Directional Vanes  
 Fully adjustable extruded  
 aluminum blades on 3/4" (19)  
 centers perpendicular to length.

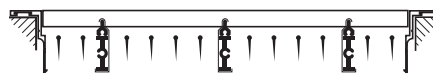

- BKP Plenum interior painted black.

SCHEDULE TYPE:

PROJECT:

ENGINEER:

CONTRACTOR:

Page 2 of 2  
 Dimensions are in inches (mm).

DATE

B SERIES

SUPERSEDES

DRAWING NO.

8 - 23 - 06

NLD

9 - 7 - 05

NLD-C