

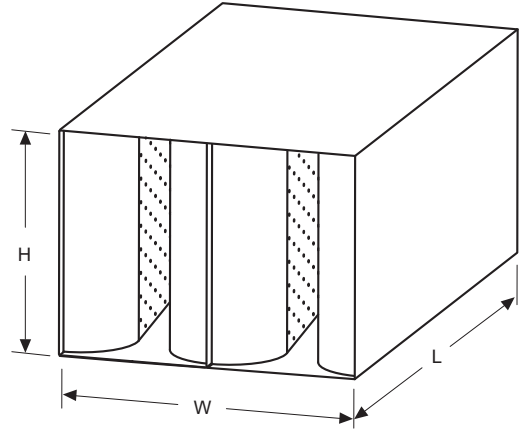

RECTANGULAR DISSIPATIVE SILENCER
BROADBAND • HIGH INSERTION LOSS
TAPERED POD DESIGN
MODEL: RBB-HP

SPECIFICATIONS:

Engineered Acoustics' dissipative, rectangular duct silencers are designed to offer superior acoustic and aerodynamic performance. Constructed with a standard outer casing of 22 gauge (0.85) galvanized steel. Each internal "pod" includes a solid 22 gauge (0.85) elliptical nosepiece, 22 gauge (0.85) acoustically transparent perforated metal, and is exponentially tapered to minimize dynamic pressure loss and maximize static pressure regain. The inorganic, odorless, vermin and moisture proof, absorption media is compressed a minimum of 5% to eliminate voids and prevent settling.



INSERTION LOSS IN DECIBELS WITH AND WITHOUT AIRFLOW (+) FORWARD FLOW (-) REVERSE FLOW

LENGTH (inches)	FACE VELOCITY (fpm)	STATIC PRESSURE DROP (in. w.g.)	OCTAVE BAND / CENTER FREQUENCY (Hz)							
			1	2	3	4	5	6	7	8
			63	125	250	500	1000	2000	4000	8000
			INSERTION LOSS (dB)							
36	-1500	.50	3	9	16	26	30	27	18	11
	-1000	.23	3	8	15	26	31	28	19	12
	0	0	3	6	14	27	36	31	21	13
	+1000	.21	3	6	13	25	35	31	21	13
	+2000	.83	2	6	12	23	32	30	19	11
60	-1000	.39	9	14	22	40	44	45	31	15
	-500	.11	10	13	21	42	46	48	33	17
	0	0	8	12	21	42	49	50	35	20
	+1000	.37	8	11	19	40	48	50	36	20
	+1500	.84	6	10	18	39	47	49	35	19
84	-1000	.40	9	18	31	39	43	45	33	19
	-500	.21	10	17	30	42	46	48	37	22
	0	0	10	16	26	45	49	51	38	23
	+1000	.38	9	14	25	44	47	48	37	22
	+1500	.86	7	14	25	44	45	46	35	20

NOTE:

- The incombustible filler material does not exceed the following fire hazard classifications when tested in accordance with NFPA 90 and UL 181: Flame spread 25, Fuel contributed 0, Smoke development 50.
- All performance data is independently tested, using a 24" x 24" (610 x 610) rectangular sample. Forward Flow (+) occurs when noise and air travel in the same direction. Reverse Flow (-) occurs when noise and air travel in opposite directions.
- Face velocities represent velocity across the total inlet area of the silencer. Static pressure drop is reported in accordance with standard ASTM E-477 involving specified lengths of straight duct before and after the test specimen. Actual system conditions may vary from the standard and require additional system performance calculations.

SELF GENERATED NOISE

FACE VELOCITY (fpm)	OCTAVE BAND / CENTER FREQUENCY (Hz)							
	1	2	3	4	5	6	7	8
	63	125	250	500	1000	2000	4000	8000
AIR FLOW GENERATED SOUND POWER LEVELS (dB)								
-1500	63	58	57	62	66	71	68	61
-1000	55	51	51	56	61	63	57	49
+1000	50	49	43	44	41	40	42	38
+2000	66	62	58	56	56	60	55	62

FACE AREA CORRECTION FACTORS

FACE AREA (sq. ft.)	.5	1	2	4	8	16	32	64	128	256
PWL CORRECTION FACTOR (dB)	-8	-6	-3	0	+3	+6	+9	+12	+15	+18

OPTIONS:

- High temperature sealant
- TDF Flange one or both ends
- Field or factory assembled multiple modules
- 1.5" (38) flange one or both ends
- 18 gauge (1.31) outer casing construction

Dimensions are in inches (mm's).

SCHEDULE TYPE:				
PROJECT:				
ENGINEER:	DATE	B SERIES	SUPERSEDES	DRAWING NO.
CONTRACTOR:	4 - 2 - 08	RBB	1 - 13 - 06	RBB-HP