

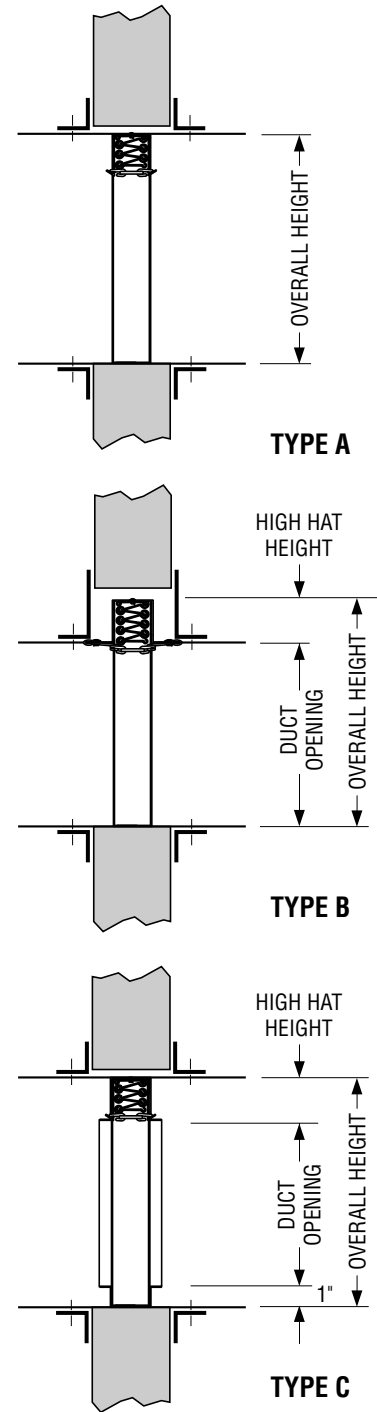

FIRE DAMPER SIZING CHART • IMPERIAL
THINLINE FRAME (2" WIDE)
MODEL SERIES 0210 – 0240, 0570 – 0590

DUCT OPENING HEIGHT (inches)	TYPE "A" OVERALL HEIGHT (inches)	TYPE "B" OVERALL HEIGHT (inches)	TYPE "C" OVERALL HEIGHT (inches)
3		5 1/8	5 3/4
4	3 3/4	6 1/8	6 3/4
5	4 3/4	7 1/8	7 3/4
6	5 3/4	8 1/8	8 3/4
7	6 3/4	9 1/8	9 3/4
8	7 3/4	10 1/8	10 3/4
9	8 3/4	11 1/8	11 3/4
10	9 3/4	13 1/8	13 3/4
11	10 3/4	14 1/8	14 3/4
12	11 3/4	15 1/8	15 3/4
13	12 3/4	16 1/8	16 3/4
14	13 3/4	17 1/8	17 3/4
15	14 3/4	18 1/8	18 3/4
16	15 3/4	20 1/8	20 3/4
17	16 3/4	21 1/8	21 3/4
18	17 3/4	22 1/8	22 3/4
19	18 3/4	23 1/8	23 3/4
20	19 3/4	25 1/8	25 3/4
21	20 3/4	26 1/8	26 3/4
22	21 3/4	27 1/8	27 3/4
23	22 3/4	28 1/8	28 3/4
24	23 3/4	29 1/8	29 3/4
25	24 3/4	30 1/8	30 3/4
26	25 3/4	32 1/8	32 3/4
27	26 3/4	33 1/8	33 3/4
28	27 3/4	34 1/8	34 3/4
29	28 3/4	35 1/8	35 3/4
30	29 3/4	36 1/8	36 3/4
31	30 3/4	37 1/8	37 3/4
32	31 3/4	39 1/8	39 3/4
33	32 3/4	40 1/8	40 3/4
34	33 3/4	41 1/8	41 3/4
35	34 3/4	43 1/8	43 3/4
36	35 3/4	44 1/8	44 3/4
37	36 3/4	45 1/8	45 3/4
38	37 3/4	46 1/8	46 3/4
39	38 3/4	47 1/8	47 3/4
40	39 3/4	48 1/8	48 3/4
41	40 3/4	50 1/8	50 3/4
42	41 3/4	51 1/8	51 3/4
43	42 3/4	52 1/8	52 3/4
44	43 3/4	53 1/8	53 3/4
45	44 3/4	54 1/8	54 3/4
46	45 3/4	55 1/8	55 3/4
47	46 3/4	57 1/8	57 3/4
48	47 3/4	58 1/8	58 3/4
49	48 3/4	59 1/8	59 3/4
50	49 3/4	60 1/8	
51	50 3/4		
52	51 3/4		
53	52 3/4		
54	53 3/4		
55	54 3/4		
56	55 3/4		
57	56 3/4		
58	57 3/4		
59	58 3/4		
60	59 3/4		

DAMPER WIDTH OVERALL
 Type "A" = Duct Opening - 1/4".
 Type "B" = Duct Opening - 1/4".
 Type "C" = Duct Opening + 1 3/4".



Dimensions are in inches (mm).

SCHEDULE TYPE:			
PROJECT:			
ENGINEER:			
CONTRACTOR:			
DATE	B SERIES	SUPERSEDES	DRAWING NO.
11 - 10 - 00R	FD	8-90/0200-3A	SC3