

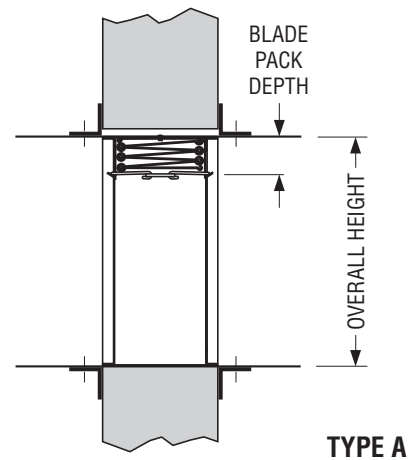

FIRE DAMPER SIZING CHART • METRIC
WIDE FRAME (152 MM WIDE)
MODELS 0310 AND 0540 TYPE A

DUCT OPENING HEIGHT (mm)	TYPE "A" OVERALL HEIGHT (mm)	BLADE PACK DEPTH (mm)
102	95	19
127	121	22
152	146	22
178	171	22
203	197	32
229	222	32
254	248	32
279	273	35
305	298	35
330	324	35
356	349	41
381	375	41
406	400	41
432	425	44
457	451	44
483	476	44
508	502	51
534	527	51
559	552	51
584	578	51
610	603	57
635	629	57
661	654	64
656	679	64
711	705	64
737	730	64
762	756	67
787	781	67
813	806	67
838	832	67
864	857	73
889	883	73
914	908	73
940	933	79
965	959	79
991	984	79
1016	1010	86
1041	1035	86
1067	1060	86
1092	1086	86
1117	1111	89
1143	1137	89
1168	1162	89
1194	1187	95
1219	1213	95
1245	1238	95
1270	1264	95
1296	1289	98
1321	1314	98
1346	1340	98
1372	1365	105
1397	1391	105
1423	1416	105
1448	1441	105
1473	1467	108
1499	1492	108
1524	1518	108



DAMPER OVERALL WIDTH
 = Duct Opening - 6.

SCHEDULE TYPE:
PROJECT:
ENGINEER:
CONTRACTOR:

Dimensions are in inches (mm).

DATE	B SERIES	SUPERSEDES	DRAWING NO.
8 - 2 - 02	FD	10 - 22 - 01	SC6