

SCREW HOLE LOCATION CHART FOR MODELS: 5100-HD AND 6100-HD

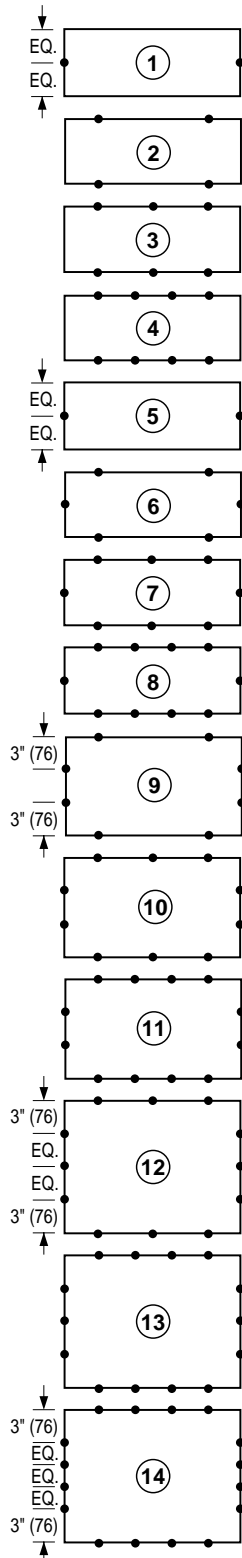

DUCT SIZE	LONG DIMENSION (WIDTH)																						
	6	8	10	12	14	16	18	20	22	24	26	28	30	32	34	36	38	40	42	44	46	48	
4																							
6																							
8			1				2					3								4			
10																							
12																							
14					5		6					7								8			
16																							
18							9																
20																							
22																							
24																							
26																							
28																							
30																							
32																							
34																							
36																							
38																							
40																							
42																							
44																							
46																							
48																							

DESCRIPTION:

1. All screw holes are located 1/2" (13) in from the outside edge of the frame.
2. Use the chart above to determine which screw hole location diagram applies based on the duct size of the grille or register.
3. This information is provided for general information only. Pre-drilling of mounting holes is not recommended. The actual grille or register, as supplied, should be used as a template to enhance the installation quality.

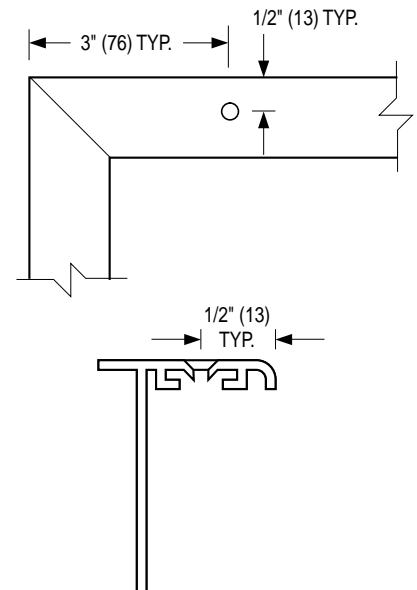

Dimensions are in inches (mm).

SCHEDULE TYPE:			
PROJECT:			
ENGINEER:			
CONTRACTOR:			
DATE	B SERIES	SUPERSEDES	DRAWING NO.
30 - 4 - 01	SUPP./G&R	NEW	SHLC-2