

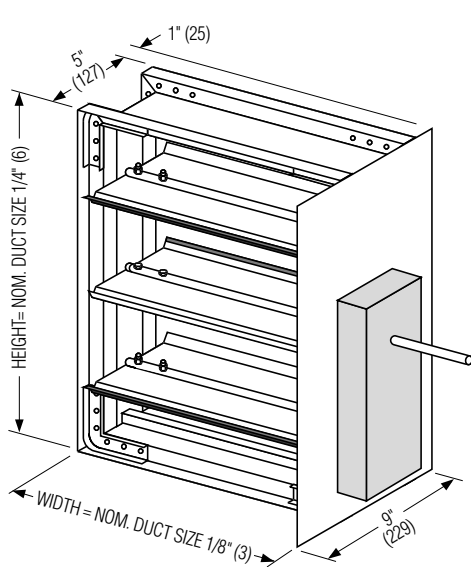

**SMP SIDE ACTUATOR MOUNTING PLATE
AND TYPE 'A' SLEEVE DETAIL
CONTROL & BALANCING DAMPERS
MODEL SERIES: 1000, 1100, 1800 & 2000**

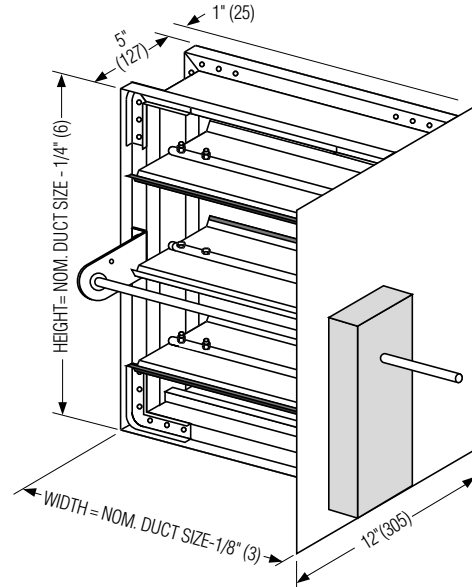

**SMP SIDE ACTUATOR MOUNTING PLATE
DIRECT DRIVE MODELS**



**SMP SIDE ACTUATOR MOUNTING PLATE
JACKSHAFT DRIVE MODELS**

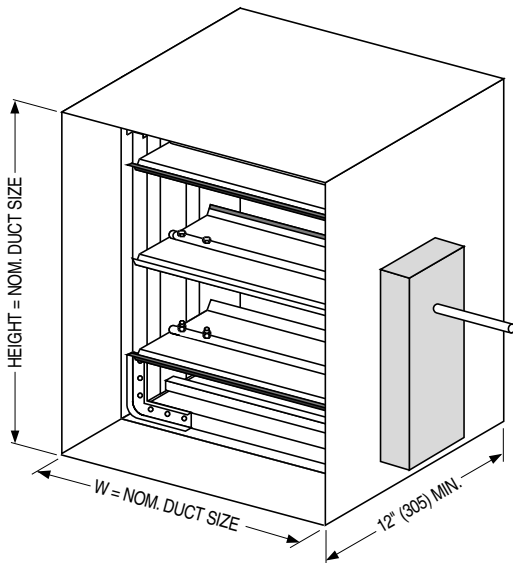

**TYPE 'A' SLEEVE
DIRECT DRIVE MODELS**

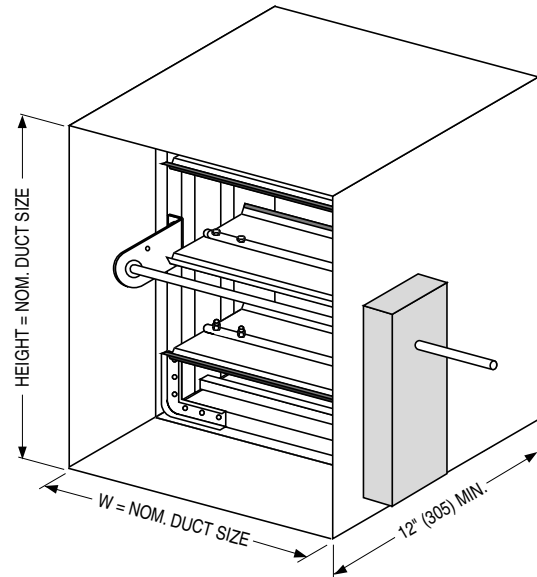

**TYPE 'A' SLEEVE
JACKSHAFT DRIVE MODELS**

SCHEDULE TYPE:	
PROJECT:	
ENGINEER:	
CONTRACTOR:	

Dimensions are in inches (mm).

DATE	B SERIES	SUPERSEDES	DRAWING NO.
11 - 4 - 13	1000	NEW	SMP-SL-2