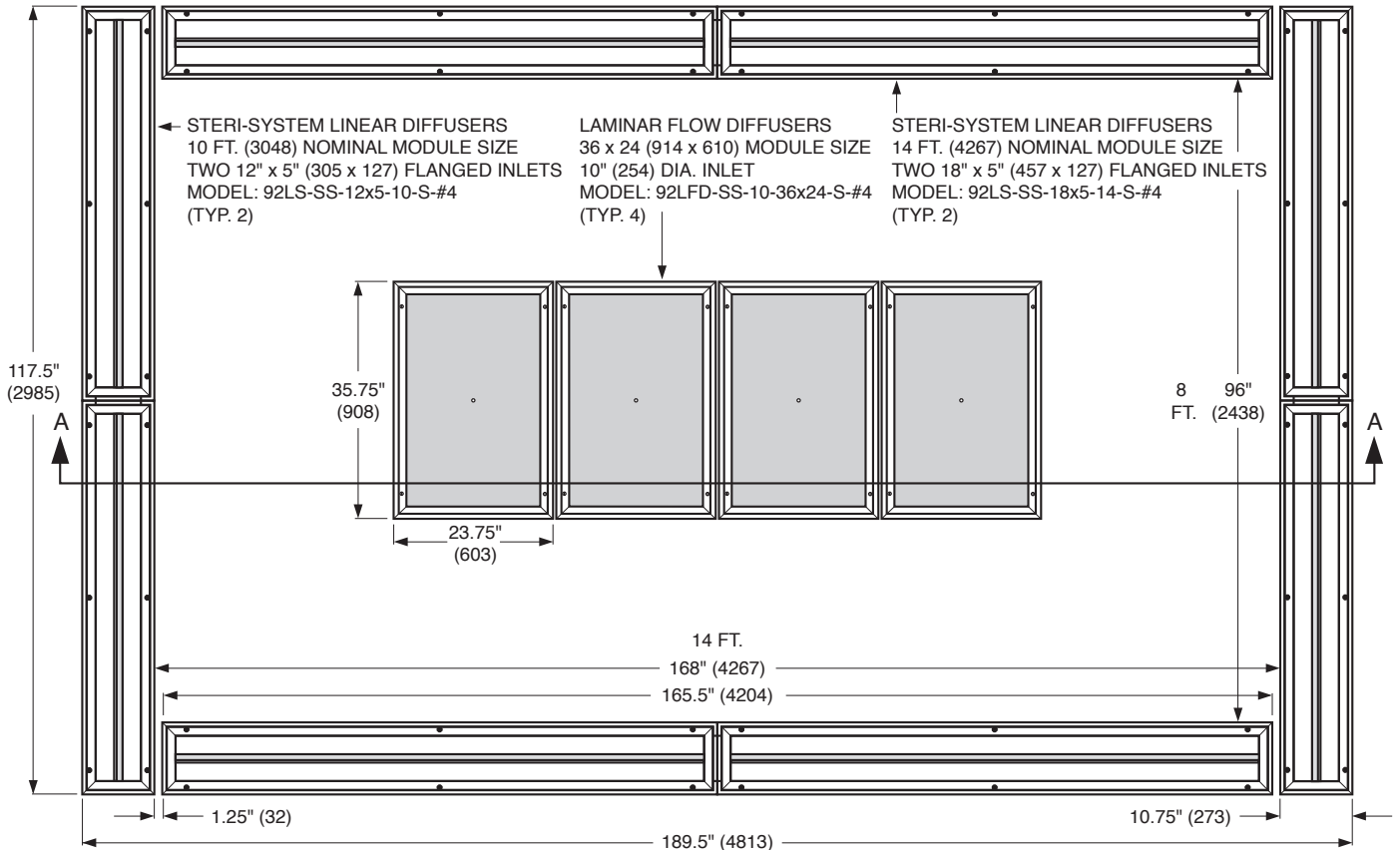

REFLECTED CEILING VIEW

DESCRIPTION:

The Steri-System is a complete operating room ventilation system, specially designed to reduce airborne contaminants, and thus, the risk of patient infection during surgery. It consists of two main components. Model 92LS-SS Linear Slot Diffusers, located around the perimeter, create a continuous curtain of air angled outwards 5 – 15 degrees. The curtain encloses the operating area and minimizes the possibility of contaminated air entering the surgical area. Model 92LFD-SS Laminar Flow Diffusers, installed above the operating table, produce a low velocity, non-aspirating, vertical air pattern. This 'clean' conditioned air flows over the operating table and greatly increases the ventilation rate within the surgical area.

CONSTRUCTION:

1. Type 304 Stainless Steel face, pressure plate and distribution plenum. Min. 22 ga.
2. Standard safety cables prevent accidental dropping of the removable face.
3. All face panels attached with stainless steel 1/4 turn fasteners.
4. Standard finish is #4 Brushed Satin Polished.

OPTIONS:

- Perimeter Inlet Balancing Dampers (Face Operated). Model 92STSYS-O.
- 316 Type 316 Stainless Steel construction.

SCHEDULE TYPE:
PROJECT:
ENGINEER:
CONTRACTOR:

 Page 1 of 2
 Dimensions are in inches (mm).

DATE	B SERIES	SUPERSEDES	DRAWING NO.
9 - 2 - 16	STERI-SYS	8 - 22 - 11	STERI-SYS-11

