

MODELS 1110 & 1120 HIGH PERFORMANCE CONTROL DAMPER STEEL AIRFOIL BLADE

Model 1110 and 1120 High Performance Control Dampers are Nailor's most economical airfoil blade control damper, suitable for use in low to medium pressure and velocity commercial HVAC systems. Design features include a steel airfoil blade for low pressure drop and reduced noise, sturdy galvanized steel hat channel frame with die-formed corner gussets for reinforcement and structural strength equivalent to 13 ga. (2.4) channel type frames and no-maintenance concealed linkage out of the air stream for reduced pressure drop and air turbulence. A variety of electric or pneumatic actuators are available for factory or field mounting. Models 1110 and 1120 Control Dampers are AMCA licensed for Air Leakage and Air Performance.



Models 1110 & 1120



Models 2010 & 2020

MODELS 2010 & 2020 HIGH PERFORMANCE CONTROL DAMPER EXTRUDED ALUMINUM AIRFOIL BLADE

Models 2010 and 2020 High Performance Extruded Aluminum Airfoil Blade Control Dampers are ideal for use in high velocity, medium pressure commercial and industrial HVAC systems. Standard features include a rugged galvanized steel hat channel frame with superior structural strength, no-maintenance concealed linkage located out of the airstream, totally enclosed within the damper frame, and heavy duty extruded aluminum airfoil blades that combine superior rigidity and deflection resistance with low pressure drop. Unique compression type seals are keyed and locked into blade extrusion offering extraordinary leakage and pressure drop characteristics. Model 2020 Opposed Blade Control Damper is AMCA licensed for Air Leakage and Air Performance.

MODELS 2010-EAF & 2020-EAF HIGH PERFORMANCE CONTROL DAMPER EXTRUDED ALUMINUM AIRFOIL BLADE & FRAME

Models 2010-EAF and 2020-EAF High Performance Control Dampers feature an extruded aluminum airfoil blade and frame, ideal for use in high velocity, medium pressure commercial and industrial HVAC systems. Features include a heavy duty corrosion resistant extruded aluminum frame, no-maintenance concealed linkage located out of the airstream, enclosed within the damper frame, and heavy duty extruded aluminum airfoil blades that combine superior rigidity and deflection resistance with low pressure drop. Unique compression type seals are keyed and locked into blade extrusion offering extraordinary leakage and pressure drop characteristics. Model 2020-EAF Opposed Blade Control Damper is AMCA licensed for Air Leakage and Air Performance.



Model 2010-EAF



Model 2020-IBF

MODELS 2010-IB/IBF & 2020-IB/IBF • INSULATED HIGH PERFORMANCE CONTROL DAMPER INSULATED EXTRUDED ALUMINUM AIRFOIL BLADE

Models 2010-IB/IBF and 2020-IB/IBF are Nailor's premium Insulated High Performance Control Dampers suitable for use in high velocity, medium pressure commercial and industrial applications where thermal conductivity is a concern. These ultra-low leakage dampers feature an insulated blade (IB) or insulated blade and frame (IBF), making them ideal for use in low temperature applications. Standard features include a heavy duty extruded aluminum frame, no-maintenance concealed linkage located out of the airstream and heavy duty extruded aluminum airfoil blades with compression type seals, keyed and locked into blade extrusion offering extraordinary leakage and pressure drop characteristics. A variety of electric or pneumatic actuators are available for factory or field mounting. Model 2020-IBF Opposed Blade Control Damper is AMCA licensed for Air Leakage and Air Performance.

FEATURES OF NAILOR CONTROL DAMPERS

At Nailor Industries, we take pride in putting our years of experience in manufacturing premium quality dampers to work for you with every control damper we make. We've learned a lot since producing our first damper in 1971 and have incorporated that knowledge into the latest designs and features that are offered today. With Nailor dampers you're in control! We manufacture your control dampers with the remarkable quality features shown below and with a multitude of options you can select from to meet your specific requirements. With Nailor's fast lead times, your control dampers will be on site when you need them. Premium quality, reasonable cost and versatility are just some the standard features found on all Nailor products!

Nailor's robust blade linkage provides firm, precise blade connections for smooth operation, concealed in frame, out of airstream for reduced turbulence and pressure drop. Double linkage provided on units 30" (762) wide and over.

Rugged 16 ga. (1.6) hat channel frame design provides strength equivalent to heavier gauge U-channel frames.

Corners are mitered and reinforced with die-formed gussets for superior rigidity and strength that virtually eliminates racking.

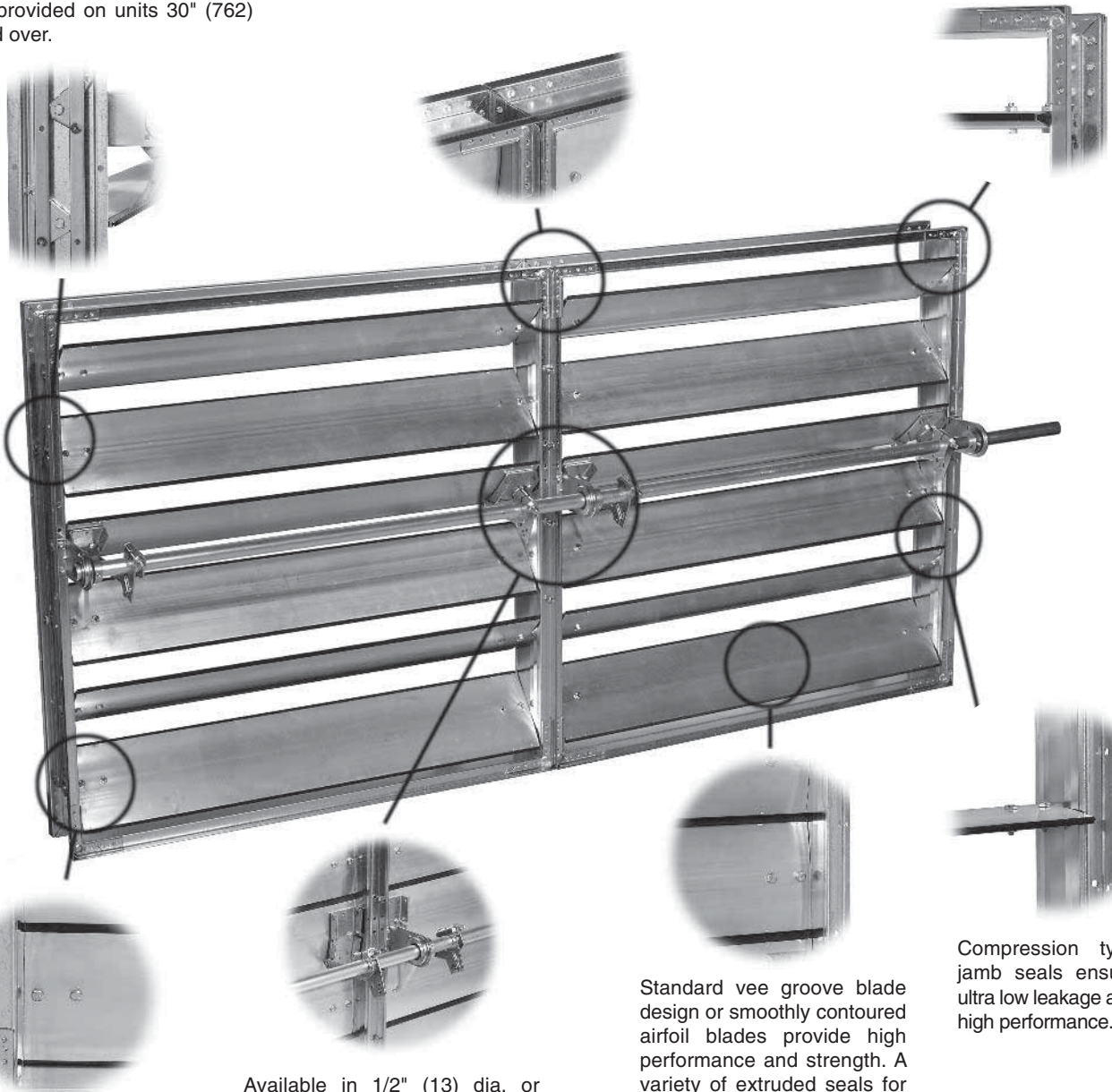

Each axle is fastened to blade end with double thru-bolts providing superior no-slip axle connections. Choice of bearings to suit application.

Available in 1/2" (13) dia. or heavy duty 1" (25) dia. shaft. A robust linkage, bearing brackets and blade connections provide optimum operation on larger dampers.

Standard vee groove blade design or smoothly contoured airfoil blades provide high performance and strength. A variety of extruded seals for various applications provide low-leakage characteristics that lead the industry.

Compression type jamb seals ensure ultra low leakage and high performance.

Quality dampers by Nailor Industries . . . Now you're in control!

CONTROL DAMPER TESTING

All AMCA certified dampers are subject to the guidelines of the Certification Ratings Program and are tested in accordance with AMCA Standard 500-D, *Laboratory Methods of Testing Dampers for Rating*. All Nailor non-AMCA certified control, balancing and backdraft dampers are tested in an independent laboratory and testing is conducted in accordance with AMCA Standard 500-D.

There are three common test setups to test pressure drop referenced in AMCA 500-D: Fig. 5.2, Fig. 5.3 and Fig. 5.5 (see below). All Nailor control dampers are tested using the configuration shown below in Fig. 5.3, illustrating a fully ducted damper. All Nailor backdraft dampers are tested using the configuration shown in Fig. 5.5, illustrating a plenum mounted damper. Fig. 5.3 yields the lowest pressure drop of the three test configurations due to minimized entrance and exit losses of the upstream and downstream straight duct runs. Fig. 5.5 has the highest pressure drop due to extremely high entrance and exit losses due to the sudden changes of area in the system.

Pressure drop data within this section has been corrected to represent standard air at a density of 0.075 lb/ft³ (1.2 kg/m³) and this data is representative of laboratory conditions. The actual pressure drop of any HVAC system is a combination of many factors. This pressure drop information along with an analysis of other system influences should be used to estimate actual pressure losses for a damper installed in a given HVAC system.

With any damper application, the amount of air leakage through the damper should be considered. If the application requires low leakage characteristics, the damper should be provided with seals. Nailor Industries offers a variety of low leakage rated dampers with blade and jamb seals suitable for most commercial and light industrial HVAC applications.

The sealing performance of a closed damper is described by the airflow leakage rate through the damper for a given pressure differential across the damper. The established sealing performance is usually expressed (or plotted) as cfm per sq. ft. (m³/s per m²) through the face area of a damper versus measured pressure differential across the damper. The published sealing performance is calculated in accordance with AMCA Standard 500-D and is a statement of the worst-case performance based on testing various damper sizes.

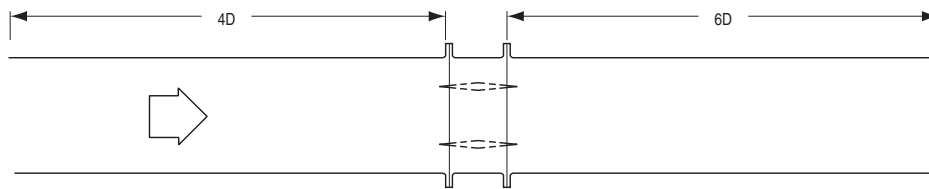

FIG. 5.3

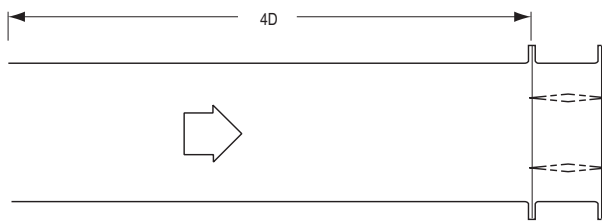

FIG. 5.2

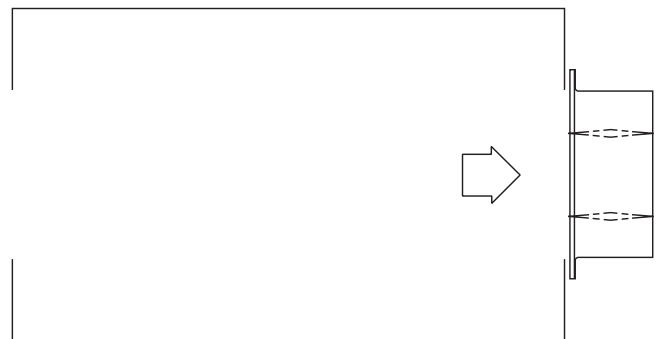

FIG. 5.5

- AMCA LICENSED
- STEEL AIRFOIL BLADE
- HIGH PERFORMANCE
- CLASS 1A LEAKAGE RATED
- GALVANIZED STEEL

CONTROL DAMPERS

Models:

- 1110 Parallel Blade
- 1120 Opposed Blade



Model 1110

Model 1120

Model 1110 and 1120 High Performance Control Dampers are Nailor's most economical steel airfoil blade control damper. Engineered for premium performance, they offer excellent leakage and pressure drop characteristics that meets the International Energy Conservation Code maximum leakage criteria for building envelope dampers of 3 cfm/ft.² @ 1" w.g. (15.2 L/s/m² @ 0.25 kPa). Suitable for use in low to medium pressure and velocity commercial HVAC systems.

Design features include a sturdy galvanized steel hat channel frame with die-formed corner gussets for reinforcement and structural strength equivalent to 13 ga. (2.4) channel type frames, no-maintenance plated steel concealed linkage enclosed within the side frame out of the airstream and heavy duty 14 ga. (2.0) equivalent steel airfoil blades with extruded PVC blade seals, offering Class 1A leakage and low pressure drop characteristics. A variety of electric or pneumatic actuators are available for factory or field mounting along with a comprehensive selection of options to meet specific installation requirements and applications. Models 1110 Parallel Blade and 1120 Opposed Blade Control Dampers are AMCA licensed for Air Leakage and Air Performance.

STANDARD CONSTRUCTION:

- Frame:** 5" x 7/8" x 16 ga. (127 x 22 x 1.6) galvanized steel hat channel with die-formed corner gussets. Low profile (flat top and bottom) on dampers 10" (254) high and under.
- Blades:** 6" (152) wide on 5 1/2" (140) centers. 20 ga. (1.0) galvanized steel formed into an airfoil cross-section. 14 ga. (2.0) equivalent thickness. Parallel or opposed action.
- Linkage:** Concealed side type totally enclosed within the frame and out of the airstream. Plated steel.
- Bearings:** 1/2" (13) dia. Oilite® self-lubricating bronze.
- Axles:** 1/2" (13) dia. plated steel double bolted to blades.
- Drive Shaft:** 6" (152) long x 1/2" (13) dia. rigid shaft; or optional lock-on shaft with outboard support bracket (standard in Canada), on all single section dampers. A 1/2" (13) or 1" (25) dia. factory installed jackshaft is standard on all multiple section dampers.

- Blade Seals:** Extruded PVC.
- Jamb Seals:** Cambered stainless steel.

Models 1110 and 1120 Sizes (Duct W x H):

Minimum		Maximum	
Single Section		Single Section	Multiple Section
Single Blade 6" x 6" (152 x 152)	Two Blades (parallel or opposed) 6" x 10" (152 x 254)	48" x 72" (1219 x 1829)	Unlimited

Temperature Range: -50°F to 180°F (-46°C to 82°C)

COMMON OPTIONS:

- Type 304 Stainless Steel construction.
- Heavier gauge frame construction.
- Front, rear or double flange frame (with or without bolt holes).
- Face and bypass configurations.
- Factory installed pneumatic and electric actuators.

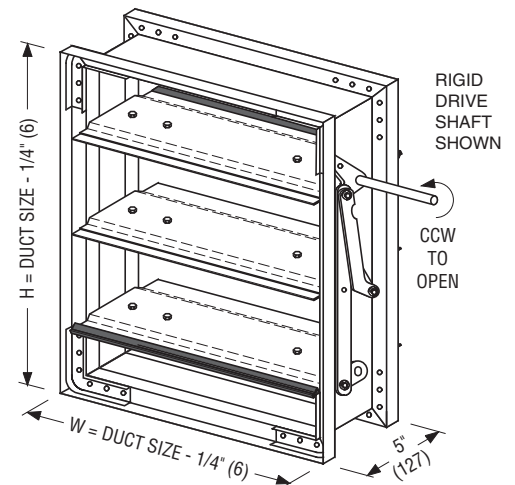

MODEL 1110
PARALLEL BLADE

MODEL 1120
OPPOSED BLADE

† jackshaft standard on multiple section dampers. Jackshaft securely bolted to frame.

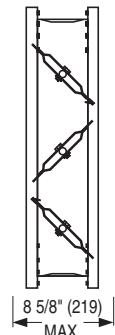
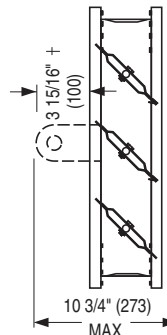

PERFORMANCE DATA: MODELS: 1110 AND 1120

DYNAMIC LIMITATIONS:

Damper Width		Maximum System Pressure	Maximum System Velocity
in.	mm		
48	1219	8.0" w.g.	4000 fpm
36	914	10.0" w.g.	4500 fpm
24	610	12.0" w.g.	5000 fpm
12	305	14.0" w.g.	6000 fpm

The 1100 Series with its standard maximum single section and multiple section sizing limitation may be used in applications with system pressures of up to 8.0" w.g.. The 1100 Series may also be used in systems with higher total pressures by reducing the damper section width as shown in the table.

LEAKAGE CLASS:

Damper Width	@ 1" w.g. (0.25 kPa)	@ 4" w.g. (1.0 kPa)
12" (305)	1A	1
24" (610)	1A	1
36" (914)	1A	1
48" (1219)	1A	1

Maximum leakage permitted for Class rating is as follows:

Class 1A: 3 cfm/sq. ft. @ 1" w.g. (15.2 l/s/m² @ 0.25 kPa)

Class 1: 8 cfm/sq. ft. @ 4" w.g. (41 l/s/m² @ 1.0 kPa)

Leakage tested in accordance with AMCA Standard 500-D. Data based on a torque of 7" lbs./sq. ft. (minimum 20" lbs.) applied to hold the damper in closed position. Leakage class is based on operation between 50°F and 104°F (10°C and 40°C). Data corrected to standard air density of 0.075 lbs/ft³.

PRESSURE DROP (damper fully open):

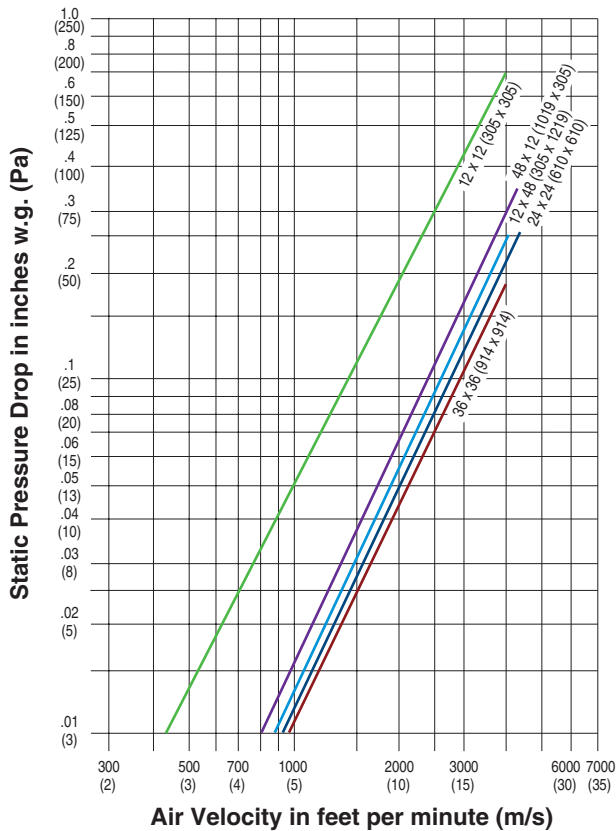

Pressure drop tested per AMCA Standard 500-D, Figure 5.3. Data corrected to standard air density of 0.075 lbs/ft³.



Nailor Industries Inc. certifies that the Models 1110 and 1120 Dampers shown herein are licensed to bear the AMCA seal. The ratings shown are based on tests and procedures performed in accordance with AMCA Publication 511 and comply with the requirements of the AMCA Certified Ratings Program. The AMCA Certified Ratings Seal applies to air leakage ratings and air performance ratings.

HOW TO SPECIFY OR TO ORDER

MODELS: 1110 AND 1120

LOW LEAKAGE CONTROL DAMPERS

SUGGESTED SPECIFICATION:

Provide and install, as shown on plans and/or schedules, ultra-low leakage control dampers as manufactured by Nailor Industries, Inc. which meet or exceed the following criteria: Frame shall be constructed of 16 ga. (1.6) galvanized steel hat channel with mitered corners and die-formed corner gussets for rigidity and structural strength equivalent to 13 ga. (2.4) channel type frames. Blades shall be 2 x 20 ga. (1.0) galvanized steel welded and formed airfoil design. Blades shall be on maximum 6" (152) centers. Blade seals shall be extruded PVC and jamb seals shall be compression type cambered stainless steel, providing positive shut-off. Blade axles shall be 1/2" (13) dia. plated steel, double thru-bolted to blade at each end. Hex, square friction-fit or press-fit axles are not acceptable. Bearings shall be Oilite® self-lubricating bronze type. Blade linkage shall be zero-maintenance, out of airstream and totally concealed within the frame. Jackshafts shall be supplied on all multiple section assemblies in order to evenly distribute torque.

All submitted performance data to be based on tests in accordance with AMCA Standard 500-D. Dampers must comply with the requirements of AMCA 511 Certified Ratings Program and be qualified to bear the AMCA Seal for Air Leakage and Air Performance. Damper widths from 12" to 48" (305 to 1219) shall meet leakage Class 1A criteria of maximum 3 cfm/sq. ft. @ 1" w.g. (15.2 L/s/m² @ .25 kPa) and 8 cfm/sq. ft. @ 4" w.g. (40.6 L/s/m² @ 1 kPa). Standard of acceptance shall be Nailor Industries (**specifier to select**) Model 1110 parallel blade or Model 1120 opposed blade control damper.

MODELS: 1110 AND 1120

FABRICATED AIRFOIL BLADE CONTROL DAMPERS

EXAMPLE: 1110 - 24 x 24 - GLV - HC - 16G - CC - BO - BVP - JSS - FMEN - DR - SMP - AUTO - 120 - SPR - MOD - CL - 4X02

1. Models

- 1110 Steel, Airfoil Blade, Parallel
- 1120 Steel, Airfoil Blade, Opposed

2. Duct Size

Width x Height (inches [mm's])

3. Construction

- GLV Galvanized Steel (default)
- 304 Type 304 Stainless Steel

4. Frame Type

- HC Hat Channel (default)
- FD Double Flange
- FDB Double Flange with Bolt Holes
- FF Flanged Front
- FFB Flanged Front with Bolt Holes
- FR Flanged Rear
- FRB Flanged Rear with Bolt Holes

5. Frame Gauge

- 16G 16 ga. standard (default)
- 14G 14 ga.
- 13G 13 ga.
- 12G 12 ga.

6. Blade Linkage Style

- LC Concealed Linkage (default)
- LF Face Linkage

7. Bearings

- BC Celcon (default)
- BO Oilite Bronze
- BS Stainless Steel

8. Blade Seals

- BVP Extruded PVC (default)

9. Jamb Seals

- JSS Stainless Steel (default)
- JSM Metallic

10. Factory Actuator Mounting

- None (default)
- FMEN External Supplied by Nailor
- FMEO External Supplied by Others
- FMIN Internal Supplied by Nailor
- FMIO Internal Supplied by Others

11. Drive Shaft Option

- DSR Rigid (default USA, International)
- DLO Lock-on Drive Shaft (default CAN)
- JK Jackshaft
- JK1 Jackshaft - 1" (25) dia.
- JK5 Jackshaft - 1/2" (13) dia.

12. Drive Location

- DR Right or Left Hand (default)
- DI Internal

OPTIONS & ACCESSORIES:

13. Optional Linkage

- None (default)
- SSL Type 304 Stainless Steel

14. Thrust Bearings for Vertical Blades

- (Single Section only)
- None (default)
- BT Thrust Bearings

15a. Side Mounting Plate

- None
- SMP Side Mounting Plate

15b. Sleeve Length

- SL = Specify**
- None (default)
- 12" - 28" (305 - 711)

16. Sleeve Gauge

- None (default)
- 20G 20 ga. standard
- 18G 18 ga.
- 16G 16 ga.
- 14G 14 ga.
- 10G 10 ga.

17. Sleeve Construction

- None (default)
- SGLV Galvanized Steel
- S304 Type 304 Stainless Steel
- SALU Aluminum

18. Transition

- None (default)
- CR Round
- CO Oval

19. Hand Locking Quadrant

- None (default)
- HL2 Quadrant with 2" (51) Bracket
- HLQ Hand Locking Quadrant

20. Vertical Inter-Connect Kit

- None (default)
- VCK Vertical Inter-Connect Kit

21. Chain Operator

- None (default)
- PCE External
- PCI Internal

22. Chain

- CH Chain Length (Specify ft.)

B CONTROL DAMPERS

OPTIONS & ACCESSORIES: (continued)

23. Actuator Selected By

- AUTO Least Cost (Auto-select)
- BEL Belimo
- HON Honeywell
- MAN Manually Select
- N/A Not Applicable
- SIE Siemens

24. Power Requirement

- 120 120 VAC
- 230 230 VAC
- 24 24 VAC
- PNU Pneumatic

25. Spring Return

- NSPR Non-Spring Return
- SPR Spring Return

26. Control Type

- 2POS Two Position
- FL Floating
- MOD Modulating
- MODF Modulating and Floating
- FMZS Modulating and Floating, Adj., 0/Span

27. Fail Position (SPR Only)

- None
- CL Close
- OP Open

28. Auxiliary Switch Package

- None
- 300 Nailor MLS-300 Position Indicator
- AUXS On Electric Actuator

29. Actuator

Electric:

- 411 ML4115 120 VAC
- 411S ML4115 120 VAC w/MLS-300H
- 412 MS4120F10 120 VAC
- 412S MS4120F12 120 VAC w/Aux. Sw.
- 462 MS4620F10 230 VAC
- 4X02 ML4X02 120 VAC
- 4X0S ML4X02 120 VAC w/MLS-300H
- 4Y02 ML4Y02 230 VAC
- 4Y0S ML4Y02 230 VAC w/MLS-300H
- 4YO MS4Y09F 230 VAC
- 4Y1S MS4Y09F 230 VAC w/MLS-300H
- 811 ML8115 24 VAC
- 811S ML8115 24 VAC w/MLS-300H
- 812 MS8120F10 24 VAC
- 812S MS8120F10 24 VAC w/Aux. Sw.
- 8X02 ML8X02 120 VAC
- 8X0S ML8X02 120 VAC w/MLS-300H
- AFC Actuator from customer
- F12 FSNF120 120 VAC
- F12S FSNF120-S 120 VAC w/Aux. Sw.
- F24 FSNF24 24 VAC
- F24S FSNF24-S 24 VAC w/Aux. Sw.
- FA12 FSAF120 120 VAC
- FA1S FSAF120-S 120 VAC w/Aux. Sw.
- FA24 FSAF24 24 VAC
- FA2S FSAF24-S 24 VAC w/Aux. Sw.
- FL12 FSLF120 120 VAC
- FL1S FSLF120-S 120 VAC w/Aux. Sw.
- FL24 FSLF24 24 VAC
- FL2S FSLF24-S 24 VAC w/Aux. Sw.
- GD1 GGD121 24 VAC
- GD2 GGD221 120 VAC

- MS4 MS4X09F 120 VAC
- MS4S MS4X09F 120 VAC w/MLS-300H
- MS8 MS8X09F 24 VAC
- MS8S MS8X09F 24 VAC w/MLS-300H
- N60 MN6105A1011 24 VAC
- N60S MN6105A1201 24 VAC w/Aux. Sw.
- N61 MN6110A1003 24 VAC
- N61S MN6110A1201 24 VAC w/Aux. Sw.
- N70 MN7505A2001 24 VAC
- N70S MN7505A2209 24 VAC w/Aux. Sw.
- N71 MN7510A2001 24 VAC
- N71S MN7510A2209 24 VAC w/Aux. Sw.
- N75 MN7520A2007 24 VAC
- N75S MN7520A2205 24 VAC w/Aux. Sw.
- S70 MS7505A2030 24 VAC
- S70S MS7505A2130 24 VAC w/Aux. Sw.
- S71 MS7510A2008 24 VAC
- S71S MS7510A2206 24 VAC w/Aux. Sw.
- S72 MS7520A2007 24 VAC
- S72S MS7520A2205 24 VAC w/Aux. Sw.

Pneumatic:

- 296 331-2961 25 psi
- 296P 331-2961PR 25 psi
- 306 331-3060 25 psi
- 306P 331-3060PR 24 V - 25 psi
- 482 331-4826 25 psi
- 482P 331-4826PR 24 V - 25 psi

Note:

1. Not all variants and options are available on all models. Refer to individual model for selection availability.

- EXTRUDED ALUMINUM AIRFOIL BLADE
- PREMIUM PERFORMANCE
- CLASS 1A LEAKAGE RATED
- STEEL FRAME

Models:

2010 Parallel Blade

2020 Opposed Blade



Model 2010

Model 2020

Model 2010 and 2020 High Performance Control Dampers combine the performance of an extruded aluminum airfoil blade with the rugged durability of a steel frame. They offer unsurpassed Class 1A leakage and pressure drop characteristics for superior performance that meets the International Energy Conservation Code maximum leakage criteria for building envelope dampers of 3 cfm/ft.² @ 1" w.g. (15.2 L/s/m² @ 0.25 kPa). Leakage rating is maintained with airflow in either direction, permitting right or left-hand drive installation. Suitable for use in high velocity, medium pressure commercial and industrial HVAC systems.

Standard features include heavy duty extruded aluminum airfoil blades that combine superior rigidity and deflection resistance with low pressure drop, a 16 ga. (1.6) galvanized steel hat channel frame with die-formed corner gussets for superior structural strength, a no-maintenance concealed linkage enclosed in the side frame out of the air stream for reduced pressure drop, air turbulence and noise, cambered stainless steel jamb seals and unique design compression type silicone seals that are keyed and locked into blade extrusion, providing the ultimate in ultra-low leakage and high performance. A comprehensive selection of options are available to meet specific installation requirements and a variety of electric or pneumatic actuators are available for factory or field mounting. Model 2020 opposed blade is AMCA licensed for Air Leakage and Air Performance.

STANDARD CONSTRUCTION:

- Frame:** 5" x 7/8" x 16 ga. (127 x 22 x 1.6) galvanized steel hat channel with die-formed corner gussets for reinforced and extra strength.
- Blades:** Airfoil type 6063-T5 extruded aluminum on 5 1/2" (140) centers. Parallel or opposed action.
- Linkage:** Concealed side type totally enclosed within the frame and out of the air stream. Plated steel.
- Bearings:** 1/2" (13) dia. Oilite® self-lubricating bronze.
- Axes:** 1/2" (13) dia. plated steel double bolted to blades.
- Drive Shaft:** 6" (152) long x 1/2" (13) dia. rigid shaft; or optional lock-on shaft with outboard support bracket (standard in Canada), on all single section dampers. A 1/2" (13) or 1" (25) dia. factory installed jackshaft is standard on all multiple section dampers.
- Blade Seals:** Silicone. Mechanically locked in place.
- Jamb Seals:** Cambered stainless steel.

Models 2010 and 2020 Sizes (Duct W x H):

Minimum		Maximum	
Single Section		Single Section	Multiple Section
Single Blade 8" x 8" (203 x 203)	Two Blades (parallel or opposed) 8" x 12" (203 x 305)	60" x 72" (1524 x 1829)	Unlimited

Temperature Range: -50°F to 250°F (-46°C to 157°C)

COMMON OPTIONS:

- Type 304 Stainless Steel construction.
- Front, rear or double flange frame (with or without bolt holes).
- Face and bypass configurations.
- Factory installed pneumatic and electric actuators.

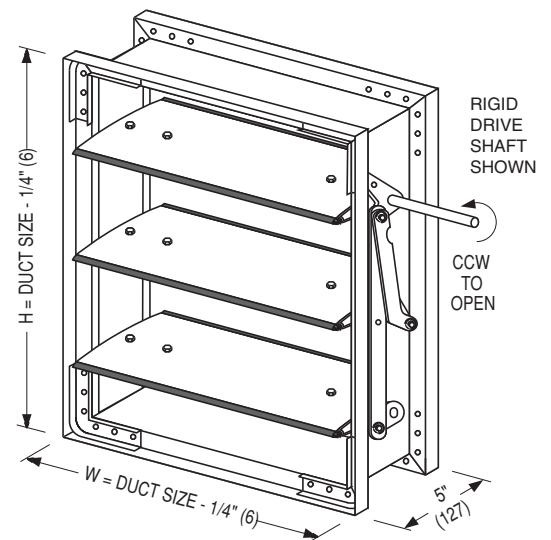

MODEL 2010
PARALLEL BLADE

MODEL 2020
OPPOSED BLADE

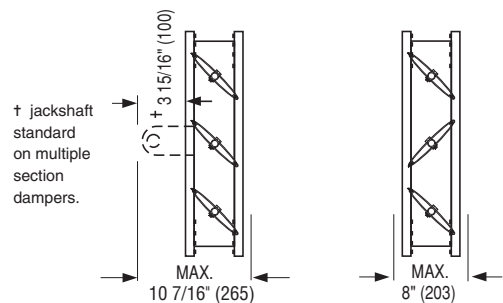

PERFORMANCE DATA:

MODELS: 2010 AND 2020

DYNAMIC LIMITATIONS:

Damper Width		Maximum System Pressure	Maximum System Velocity
in.	mm		
60	1524	5.0" w.g.	3000 fpm
48	1219	8.0" w.g.	4000 fpm
36	914	10.0" w.g.	4500 fpm
24	610	12.0" w.g.	5000 fpm
12	305	14.0" w.g.	6000 fpm

The 2000 Series with its standard maximum single section and multiple section sizing limitation may be used in applications with system pressures of up to 5.0" w.g.. The 2000 Series may also be used in systems with higher total pressures by reducing the damper section width as shown in the table.

LEAKAGE CLASS:

Damper Width	@ 1" w.g. (0.25 kPa)	@ 4" w.g. (1.0 kPa)
12" (305)	1A	1
24" (610)	1A	1
36" (914)	1A	1
48" (1219)	1A	1
60" (1524)	1A	1

Maximum leakage permitted for Class rating is as follows:

Class 1A: 3 cfm/sq. ft. @ 1" w.g. (15.2 l/s/m² @ 0.25 kPa)

Class 1: 8 cfm/sq. ft. @ 4" w.g. (41 l/s/m² @ 1.0 kPa)

Leakage tested in accordance with AMCA Standard 500-D. Data based on a torque of 8" lbs./sq. ft. (minimum 20" lbs.) applied to hold the damper in closed position. Leakage class is based on operation between 50°F and 104°F (10°C and 40°C). Data corrected to standard air density of 0.075 lbs./ft.³

PRESSURE DROP (damper fully open):

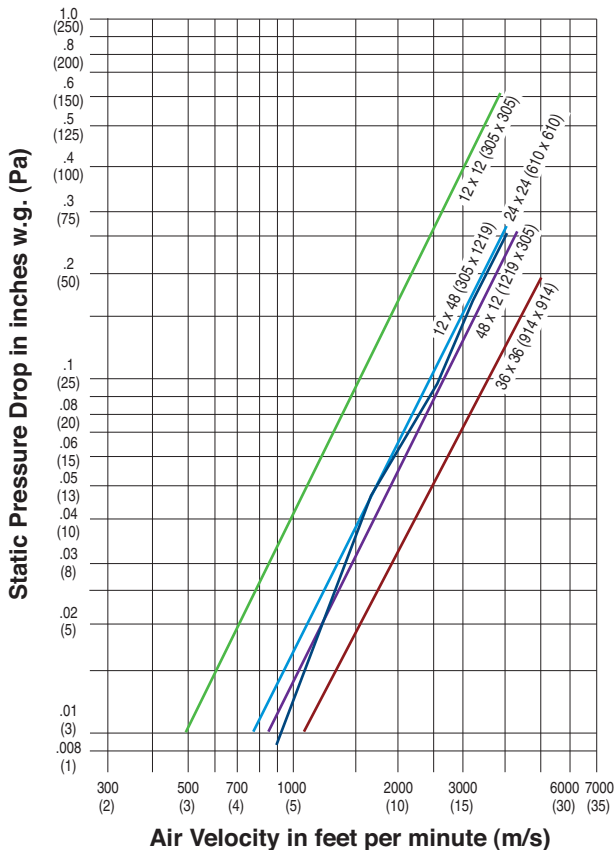

Pressure drop tested per AMCA Standard 500-D, Figure 5.3. Data corrected to standard air density of 0.075 lbs./ft.³.



Nailor Industries Inc. certifies that the Model 2020 Damper shown herein is licensed to bear the AMCA seal. The ratings shown are based on tests and procedures performed in accordance with AMCA Publication 511 and comply with the requirements of the AMCA Certified Ratings Program. The AMCA Certified Ratings Seal applies to air leakage ratings and air performance ratings. Model 2010 is not licensed to bear the AMCA seal.

HOW TO SPECIFY**MODELS: 2010 AND 2020****HIGH PERFORMANCE, ULTRA-LOW LEAKAGE CONTROL DAMPERS****SUGGESTED SPECIFICATION:**

Provide and install, as shown on plans and/or schedules, high performance ultra-low leakage control dampers as manufactured by Nailor Industries, Inc. which meet or exceed the following criteria: Frame shall be constructed of 16 ga. (1.6) galvanized steel hat channel with mitered corners and die-formed corner gussets for rigidity and structural strength equivalent to 13 ga. (2.4) channel type frames. Blades shall be of Type 6063-T5 extruded aluminum airfoil design on maximum 6" (152) centers with integral structural reinforcing tube running full length of each blade. Blade seals shall be extruded silicone mechanically locked in extruded blade slots and shall be field replaceable. Adhesive or clip-on type blade seals are not acceptable. Jamb seals shall be compression type stainless steel. Blade axles shall be 1/2" (13) dia plated steel, double thru-bolted to blade at each end to provide positive locking connection. Hex, square friction-fit or press-fit axles are not acceptable. Bearings shall be Oilite® self-lubricating bronze type. Blade linkage shall be zero-maintenance, out of airstream and totally concealed within the frame. Jackshafts shall be supplied on all multiple section assemblies in order to evenly distribute torque.

(Specifier to select) Submitted performance data, to be based on tests in accordance with AMCA Standard 500-D. Damper widths from 12" to 60" (305 to 1524) shall meet leakage Class 1A criteria of maximum 3 cfm/sq. ft. @ 1" w.g. (15.2 L/s/m² @ .25 kPa) and 8 cfm/sq. ft. @ 4" w.g. (40.6 L/s/m² @ 1 kPa). Standard of acceptance shall be Nailor Industries Model 2010 high performance parallel blade control damper **or** Dampers must comply with the requirements of AMCA 511 Certified Ratings Program and be qualified to bear the AMCA Seal for Air Leakage and Air Performance. Standard of acceptance shall be Nailor Industries Model 2020 high performance opposed blade control damper.

- EXTRUDED ALUMINUM AIRFOIL BLADE AND FRAME
- PREMIUM PERFORMANCE
- CLASS 1A LEAKAGE RATED

Models:

2010-EAF Parallel Blade

2020-EAF Opposed Blade



Model 2020-EAF

Model 2010-EAF and 2020-EAF High Performance Control Dampers feature an extruded aluminum airfoil blade and frame, ideal for use in high velocity, medium pressure, commercial and industrial HVAC systems. They offer unsurpassed Class 1A leakage and pressure drop characteristics for superior performance that meets the International Energy Conservation Code maximum leakage criteria for building envelope dampers of 3 cfm/ft.² @ 1" w.g. (15.2 L/s/m² @ 0.25 kPa).

Standard features include a heavy duty corrosion resistant extruded aluminum hat channel frame, extruded aluminum airfoil blade with outstanding pressure drop characteristics, superior rigidity and deflection resistance, no-maintenance plated steel concealed linkage enclosed within the side frame out of the airstream, long life self-lubricating bronze bearings, cambered stainless steel jamb seals and compression type silicone seals that are keyed and locked into blade extrusion, providing the ultimate in ultra-low leakage and high performance. A variety of electric or pneumatic actuators are available for factory or field mounting along with a comprehensive selection of options to meet specific installation requirements and applications. Model 2020-EAF opposed blade control damper is AMCA licensed for Air Leakage and Air Performance.

STANDARD CONSTRUCTION:

Frame: 5" x 7/8" x 0.125" (127 x 22 x 3.2) type 6063-T5 extruded aluminum frame.

Blades: Airfoil type 6063-T5 extruded aluminum on 5 1/2" (140) centers. Parallel or opposed action.

Linkage: Concealed side type totally enclosed within the frame and out of the air stream. Plated steel.

Bearings: 1/2" (13) dia. Oilite® self-lubricating bronze.

Axles: 1/2" (13) dia. plated steel double bolted to blades.

Drive Shaft: 6" (152) long x 1/2" (13) dia. rigid shaft; or optional lock-on shaft with outboard support bracket (standard in Canada), on all single section dampers. A 1/2" (13) or 1" (25) dia. factory installed jackshaft is standard on all multiple section dampers.

Blade Seals: Silicone. Mechanically locked in place.

Jamb Seals: Cambered stainless steel.

Models 2010-EAF and 2020-EAF Sizes (Duct W x H):

Minimum		Maximum	
Single Section	Two Blades (parallel or opposed)	Single Section	Multiple Section
Single Blade 8" x 8" (203 x 203)	8" x 12" (203 x 305)	60" x 72" (1524 x 1829)	Unlimited

Temperature Range: -50°F to 250°F (-46°C to 157°C)

COMMON OPTIONS:

- Face and bypass configurations.
- Factory installed pneumatic and electric actuators.

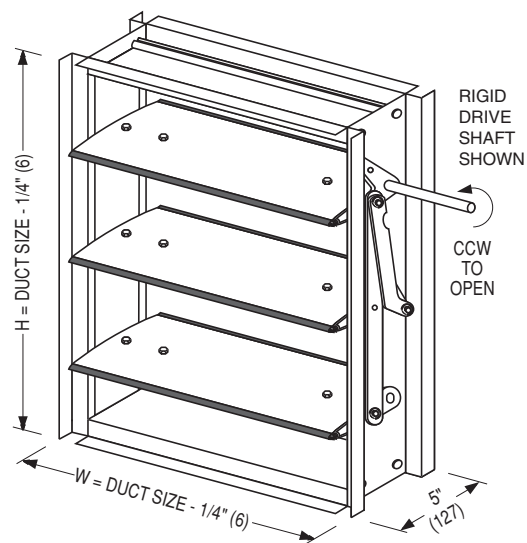

MODEL 2010-EAF
PARALLEL BLADE

MODEL 2020-EAF
OPPOSED BLADE

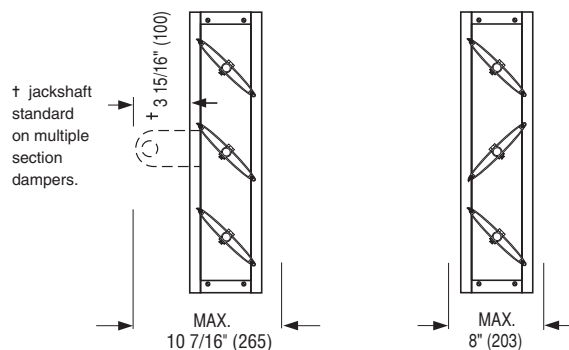

B
CONTROL DAMPERS

PERFORMANCE DATA:

MODELS: 2010-EAF AND 2020-EAF

DYNAMIC LIMITATIONS:

Damper Width		Maximum System Pressure	Maximum System Velocity
in.	mm		
60	1524	5.0" w.g.	3000 fpm
48	1219	8.0" w.g.	4000 fpm
36	914	10.0" w.g.	4500 fpm
24	610	12.0" w.g.	5000 fpm
12	305	14.0" w.g.	6000 fpm

The 2000 Series with its standard maximum single section and multiple section sizing limitation may be used in applications with system pressures of up to 5.0" w.g.. The 2000 Series may also be used in systems with higher total pressures by reducing the damper section width as shown in the table.

LEAKAGE CLASS:

Damper Width	@ 1" w.g. (0.25 kPa)	@ 4" w.g. (1.0 kPa)
12" (305)	1A	1
24" (610)	1A	1
36" (914)	1A	1
48" (1219)	1A	1
60" (1524)	1A	1

Maximum leakage permitted for Class rating is as follows:

Class 1A: 3 cfm/sq. ft. @ 1" w.g. (15.2 l/s/m² @ 0.25 kPa)

Class 1: 8 cfm/sq. ft. @ 4" w.g. (41 l/s/m² @ 1.0 kPa)

Leakage tested in accordance with AMCA Standard 500-D. Data based on a torque of 8" lbs./sq. ft. (minimum 20" lbs.) applied to hold the damper in closed position. Leakage class is based on operation between 50°F and 104°F (10°C and 40°C). Data corrected to standard air density of 0.075 lbs./ft.³

PRESSURE DROP (damper fully open):

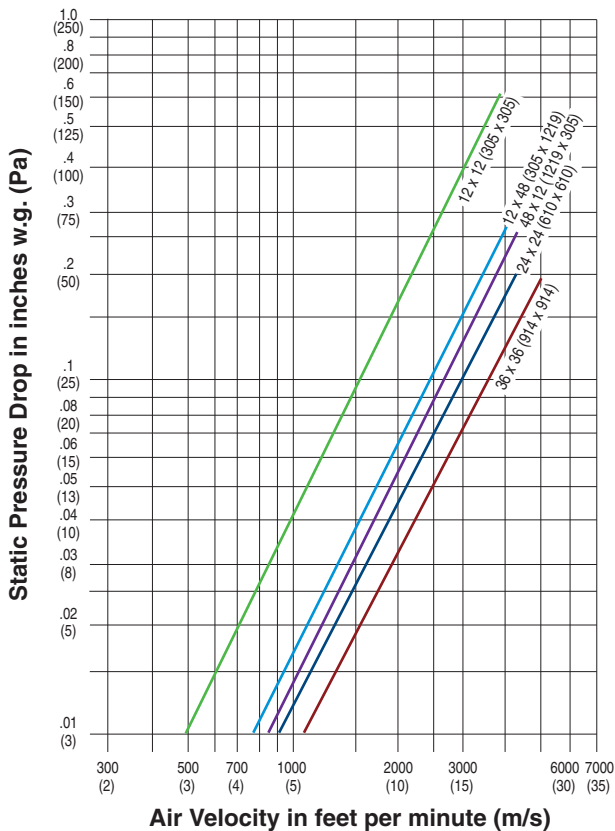

Pressure drop tested per AMCA Standard 500-D, Figure 5.3. Data corrected to standard air density of 0.075 lbs./ft.³.



Nailor Industries Inc. certifies that the Model 2020-EAF Damper shown herein is licensed to bear the AMCA seal. The ratings shown are based on tests and procedures performed in accordance with AMCA Publication 511 and comply with the requirements of the AMCA Certified Ratings Program. The AMCA Certified Ratings Seal applies to air leakage ratings and air performance ratings. Model 2010-EAF is not licensed to bear the AMCA seal.

HOW TO SPECIFY**MODELS: 2010-EAF AND 2020-EAF
HIGH PERFORMANCE CONTROL DAMPERS****SUGGESTED SPECIFICATION:**

Provide and install, as shown on plans and/or schedules, ultra-low leakage dampers as manufactured by Nailor Industries, Inc. which meet or exceed the following criteria: Frame shall be constructed of type 6063-T5 extruded aluminum hat channel design of minimum 0.125" (3.2) thickness. Blades shall be of Type 6063-T5 extruded aluminum airfoil design on maximum 6" (152) centers with integral structural reinforcing tube running full length of each blade. Blade seals shall be extruded silicone mechanically locked in extruded blade slots and shall be field replaceable. Adhesive or clip-on type blade seals are not acceptable. Jamb seals shall be compression type stainless steel. Blade axles shall be 1/2" (13) dia plated steel, double thru-bolted to blade at each end to provide positive locking connection. Hex, square friction-fit or press-fit axles are not acceptable. Bearings shall be Oilite® self-lubricating bronze type. Blade linkage shall be zero-maintenance, out of airstream and totally concealed within the frame. Jackshafts shall be supplied on all multiple section assemblies in order to evenly distribute torque.

(Specifier to select) Submitted performance data, to be based on tests in accordance with AMCA Standard 500-D. Damper widths from 12" to 60" (305 to 1524) shall meet leakage Class 1A criteria of maximum 3 cfm/sq. ft. @ 1" w.g. (15.2 L/s/m² @ .25 kPa) and 8 cfm/sq. ft. @ 4" w.g. (40.6 L/s/m² @ 1 kPa). Standard of acceptance shall be Nailor Industries Model 2010-EAF high performance parallel blade control damper **or** Dampers must comply with the requirements of AMCA 511 Certified Ratings Program and be qualified to bear the AMCA Seal for Air Leakage and Air Performance. Standard of acceptance shall be Nailor Industries Model 2020-EAF high performance opposed blade control damper.

- INSULATED DAMPER
- EXTRUDED ALUMINUM AIRFOIL BLADE
- PREMIUM PERFORMANCE
- ULTRA-LOW LEAKAGE

CONTROL DAMPERS



Model 2020-IBF

Models:

2010-IB/-IBF Parallel Blade

2020-IB/-IBF Opposed Blade

Models 2010-IB/2010-IBF and 2020-IB/2020-IBF Insulated High Performance Control Dampers are ideal for use in high velocity, medium pressure commercial and industrial applications where thermal conductivity is a concern. These ultra-low leakage dampers limit thermal conductivity as well as air infiltration, making them ideal for use in low temperature applications. They offer unsurpassed leakage and pressure drop characteristics for superior performance that meets the International Energy Conservation Code maximum leakage criteria for building envelope dampers of 3 cfm/ft.² @ 1" w.g. (15.2 L/s/m² @ 0.25 kPa).

Standard features include rugged extruded aluminum airfoil blades insulated with polyurethane foam, a 16 ga. (1.6) galvanized steel hat channel frame (-IBF models feature polystyrene foam insulated frames), no-maintenance plated steel concealed linkage enclosed within the side frame out of the airstream, long life self-lubricating bronze bearings, cambered stainless steel jamb seals and compression type silicone seals that are keyed and locked into the blade extrusion, providing low pressure drop and high performance. A variety of electric or pneumatic actuators are available for factory or field mounting along with a comprehensive selection of options to meet specific installation requirements and applications. Model 2020-IBF Opposed Blade Control Damper is AMCA licensed for Air Leakage and Air Performance.

STANDARD CONSTRUCTION:

- Frame:** 5" x 7/8" x 16 ga. (127 x 22 x 1.6) galvanized steel hat channel with die-formed corner gussets for reinforcement and extra strength.
- Blades:** Airfoil type 6063-T5 extruded aluminum on 5 1/2" (140) centers. Parallel or opposed action.
- Insulation:** Blades: Polyurethane foam; R value 2.19 (IB/IBF models).
Frame: Polystyrene foam; (Included with IBF model only).
- Linkage:** Concealed side type totally enclosed within the frame and out of the airstream. Plated steel.
- Bearings:** 1/2" (13) dia. Oilite® self-lubricating bronze.
- Axes:** 1/2" (13) dia. plated steel double bolted to blades.
- Drive Shaft:** 6" (152) long x 1/2" (13) dia. rigid shaft; or optional lock-on shaft with outboard support bracket (standard in Canada), on all single section dampers. A 1/2" (13) or 1" (25) dia. factory installed jackshaft is standard on all multiple section dampers.
- Blade Seals:** Silicone. Mechanically locked in place.
- Jamb Seals:** Cambered stainless steel.

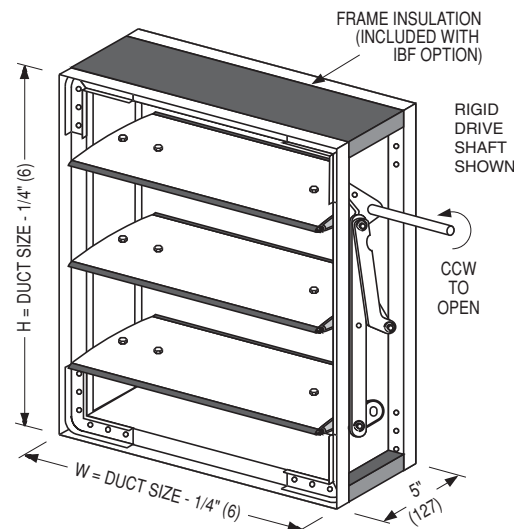

NOTE: IB MODEL: INSULATED BLADE ONLY
IBF MODEL: INSULATED BLADE AND FRAME

Models 2010-IB/-IBF and 2020-IB/-IBF Sizes (Duct W x H):

Minimum		Maximum	
Single Section		Single Section	Multiple Section
Single Blade 8" x 8" (203 x 203)	Two Blades (parallel or opposed) 8" x 12" (203 x 305)	60" x 72" (1524 x 1829)	Unlimited

Temperature Range: -50°F to 250°F (-46°C to 157°C)

COMMON OPTIONS:

- Extruded Aluminum or Type 304 Stainless Steel construction.
- Front, rear or double flange frame (with or without bolt holes).
- Face and bypass configurations.
- Factory installed pneumatic and electric actuators.

MODELS 2010-IB/-IBF PARALLEL BLADE **MODELS 2020-IB/-IBF OPPOSED BLADE**

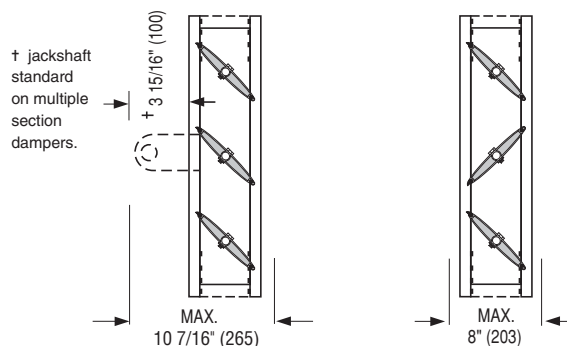

PERFORMANCE DATA:

MODELS: 2010-IB/-IBF AND 2020-IB/-IBF

A WORD ABOUT INSULATED DAMPERS...

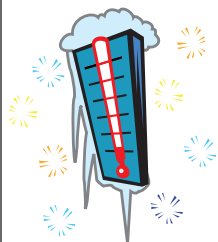

Air infiltration between the damper blades and frame is the most significant factor attributed to frost build-up on and around outside air dampers which can lead to damper/actuator damage and potential for further system damage such as coil freeze-ups etc. With an ultra-low mean leakage rate of 0.18 CFM/sq. ft. (0.91 l/s per sq. meter) at 1" w.g. (.25 kPa) static pressure combined with insulated blades and frame, the Nailor 2000-IBF Series provides the protection required for many applications in harsher climates...

NAILOR COMBINES THE LOWEST LEAKAGE MULTI-BLADE DAMPER, THAT IS AMCA LICENSED, WITH THE LOW HEAT CONDUCTIVITY DESIGN OF INSULATED BLADE AND FRAME.

This combination provides excellent protection for colder ambient conditions!

DYNAMIC LIMITATIONS:

Damper Width		Maximum System Pressure	Maximum System Velocity
in.	mm		
60	1524	5.0" w.g.	3000 fpm
48	1219	8.0" w.g.	4000 fpm
36	914	10.0" w.g.	4500 fpm
24	610	12.0" w.g.	5000 fpm
12	305	14.0" w.g.	6000 fpm

The 2000 Series with its standard maximum single section and multiple section sizing limitation may be used in applications with system pressures of up to 5.0" w.g.. The 2000 Series may also be used in systems with higher total pressures by reducing the damper section width as shown in the table.

LEAKAGE CLASS:

Damper Width	@ 1" w.g. (0.25 kPa)	@ 4" w.g. (1.0 kPa)
12" (305)	1A	1
24" (610)	1A	1
36" (914)	1A	1
48" (1219)	1A	1
60" (1524)	1A	1

Maximum leakage permitted for Class rating is as follows:

Class 1A: 3 cfm/sq. ft. @ 1" w.g. (15.2 l/s/m² @ 0.25 kPa)

Class 1: 8 cfm/sq. ft. @ 4" w.g. (41 l/s/m² @ 1.0 kPa)

Leakage tested in accordance with AMCA Standard 500-D. Data based on a torque of 8" lbs./sq. ft. (minimum 20" lbs.) applied to hold the damper in closed position. Leakage class is based on operation between 50°F and 104°F (10°C and 40°C). Data corrected to standard air density of 0.075 lbs./ft.³

PRESSURE DROP (damper fully open):

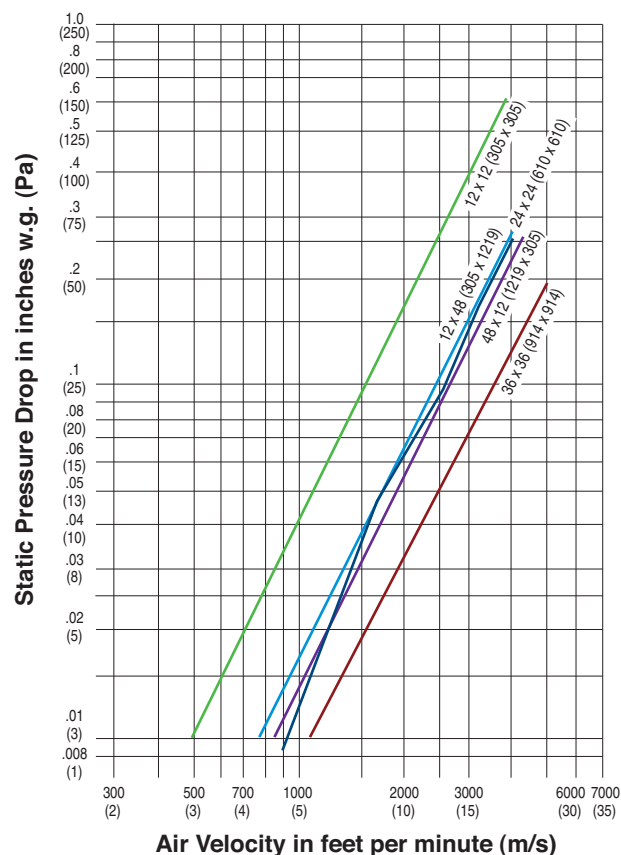

Pressure drop tested per AMCA Standard 500-D, Figure 5.3. Data corrected to standard air density of 0.075 lbs./ft.³.



Nailor Industries Inc. certifies that the Model 2020-IBF Damper shown herein is licensed to bear the AMCA seal. The ratings shown are based on tests and procedures performed in accordance with AMCA Publication 511 and comply with the requirements of the AMCA Certified Ratings Program. The AMCA Certified Ratings Seal applies to air leakage ratings and air performance ratings. Model 2010-IBF is not licensed to bear the AMCA seal.

HOW TO SPECIFY

MODELS: 2010-IB/-IBF AND 2020-IB/-IBF

HIGH PERFORMANCE, INSULATED CONTROL DAMPERS

**B
CONTROL DAMPERS**

SUGGESTED SPECIFICATION:

Provide and install, as shown on plans and/or schedules, ultra-low leakage insulated dampers as manufactured by Nailor Industries, Inc. which meet or exceed the following criteria: Frame shall be constructed of 16 ga. (1.6) galvanized steel hat channel with mitered corners and die-formed corner gussets for rigidity and structural strength equivalent to 13 ga. (2.4) channel type frames. Blades shall be of Type 6063-T5 extruded aluminum airfoil design on maximum 6" (152) centers with integral structural reinforcing tube running full length of each blade. Blades shall be internally insulated with polyurethane type foam having an R value of 2.19. Blade seals shall be extruded silicone mechanically locked in extruded blade slots. Adhesive or clip-on type blade seals are not acceptable. Jamb seals shall be compression type stainless steel. Blade axles shall be 1/2" (13) dia. plated steel, double thru-bolted to blade at each end to provide positive locking connection. Hex, square friction-fit or press-fit axles are not acceptable. Bearings shall be Oilite® self-lubricating bronze type. Blade linkage shall be zero-maintenance, out of airstream and totally concealed within the frame. Jackshafts shall be supplied on all multiple section assemblies in order to evenly distribute torque.

(Specifier to select) Submitted performance data, to be based on tests in accordance with AMCA Standard 500-D. Damper widths from 12" to 60" (305 to 1524) shall meet leakage Class 1A criteria of maximum 3 cfm/sq. ft. @ 1" w.g. (15.2 L/s/m² @ .25 kPa) and 8 cfm/sq. ft. @ 4" w.g. (40.6 L/s/m² @ 1 kPa). Standard of acceptance shall be Nailor Industries Model 2010-IB high performance parallel blade control damper **or** Dampers must comply with the requirements of AMCA 511 Certified Ratings Program and be qualified to bear the AMCA Seal for Air Leakage and Air Performance. Standard of acceptance shall be Nailor Industries Model 2020-IB high performance opposed blade control damper.

(Specifier include following for insulated frame) Frame shall be insulated with polystyrene type foam having an R value of 5.0, on minimum of three sides.

(Specifier to select) Standard of acceptance shall be Nailor Industries Model 2010-IBF high performance parallel blade control damper **or** Standard of acceptance shall be Nailor Industries Model 2020-IBF high performance opposed blade control damper.

Note: For Extruded Aluminum Frame (Option EAF) replace frame construction specification details with the following: Frame shall be constructed of Type 6063-T5 extruded aluminum hat channel design of minimum 0.125" (3.2) thickness.

HOW TO ORDER

MODELS: 2010 AND 2020

EXTRUDED ALUMINUM AIRFOIL BLADE CONTROL DAMPERS

EXAMPLE: 2020 - 24x24 - GLV - HC - BO - FMEN - DSR - DR - SMP - AUTO - 120 - SPR - 2POS - CL - AUXS - 411S

- | | | |
|---|--|---|
| <p>1. Models
 2010 Extruded Aluminum Airfoil Blade, Parallel
 2020 Extruded Aluminum Airfoil Blade, Opposed</p> <p>2. Duct Size
 Width x Height (inches [mm's])</p> <p>3. Construction (Frame)
 GLV Galvanized Steel (default)
 EAF Extruded Aluminum
 SSF Type 304 Stainless Steel</p> <p>4. Frame Type
 HC Hat Channel (default)
 FD Double Flange
 FDB Double Flange with Bolt Holes
 FF Flanged Front
 FFB Flanged Front with Bolt Holes
 FR Flanged Rear
 FRB Flanged Rear with Bolt Holes</p> | <p>5. Insulation
 - None (default)
 IB Blades
 IBF Blades and Frame</p> <p>6. Bearings
 BO Oilite Bronze (default)
 BS Stainless Steel</p> <p>7. Factory Actuator Mounting
 - None (default)
 FMEN External Supplied by Nailor
 FMEO External Supplied by Others
 FMIN Internal Supplied by Nailor
 FMIO Internal Supplied by Others</p> <p>8. Drive Shaft Option
 DSR Rigid (default USA, International)
 DLO Lock-on Drive Shaft (default CAN)
 JK Jackshaft
 JK1 Jackshaft - 1" (25) dia.
 JK5 Jackshaft - 1/2" (13) dia.</p> <p>9. Drive Location
 DR Right or Left Hand (default)
 DI Internal</p> | <p>OPTIONS & ACCESSORIES:</p> <p>10. Optional Linkage
 SSA Type 304 Stainless Steel Axles Only
 SSL Type 304 Stainless Steel</p> <p>11. Thrust Bearings
 - None (default)
 BT Thrust Bushings</p> <p>12a. Side Mounting Plate
 - None
 SMP Side Mounting Plate</p> <p>12b. Sleeve Length
 SL = Specify
 - None (default)
 12" - 28" (305 - 711)</p> <p>13. Sleeve Gauge
 - None (default)
 20G 20 ga. standard
 18G 18 ga.
 16G 16 ga.
 14G 14 ga.
 10G 10 ga.</p> |
|---|--|---|

OPTIONS & ACCESSORIES: (continued)

14. Sleeve Construction

- None (default)
- SGLV Galvanized Steel
- S304 Type 304 Stainless Steel
- SALU Aluminum

15. Transition

- None (default)
- CR Round
- CO Oval

16. Hand-Locking Quadrant

- None (default)
- HL2 Quadrant with 2" (51) Bracket
- HLQ Hand-Locking Quadrant

17. Vertical Inter-Connect Kit

- None (default)
- VCK Vertical Inter-Connect Kit

18. Chain Operator

- None (default)
- PCE External
- PCI Internal

19. Chain

- CH Chain Length (Specify ft.)

20. Actuator Selected By

- AUTO Least Cost (Auto-select)
- BEL Belimo
- HON Honeywell
- MAN Manually Select
- N/A Not Applicable
- SIE Siemens

21. Power Requirement

- 120 120 VAC
- 230 230 VAC
- 24 24 VAC
- PNU Pneumatic

22. Spring Return

- NSPR Non-Spring Return
- SPR Spring Return

23. Control Type

- 2POS Two Position
- FL Floating
- MOD Modulating
- MODF Floating and Modulating
- FMZS Floating and Modulating, Adj., 0/Span

24. Fail Position (SPR Only)

- None
- CL Close
- OP Open

25. Auxiliary Switch Package

- None
- 300 Nailor MLS-300 Position Indicator
- AUXS On Electric Actuator

26. Actuator

Electric:

- 411 ML4115 120 VAC
- 411S ML4115 120 VAC w/MLS-300H
- 412 MS4120F10 120 VAC
- 412S MS4120F12 120 VAC w/Aux. Sw.
- 462 MS4620F10 230 VAC
- 4X02 ML4X02 120 VAC
- 4X0S ML4X02 120 VAC w/MLS-300H
- 4Y02 ML4Y02 230 VAC
- 4Y0S ML4Y02 230 VAC w/MLS-300H
- 4Y0 MS4Y09F 230 VAC
- 4Y1S MS4Y09F 230 VAC w/MLS-300H
- 811 ML8115 24 VAC
- 811S ML8115 24 VAC w/MLS-300H
- 812 MS8120F10 24 VAC
- 812S MS8120F10 24 VAC w/Aux. Sw.
- 8X02 ML8X02 120 VAC
- 8X0S ML8X02 120 VAC w/MLS-300H
- AFC Actuator from customer
- F12 FSNF120 120 VAC
- F12S FSNF120-S 120 VAC w/Aux. Sw.
- F24 FSNF24 24 VAC
- F24S FSNF24-S 24 VAC w/Aux. Sw.
- FA12 FSAF120 120 VAC
- FA1S FSAF120-S 120 VAC w/Aux. Sw.
- FA24 FSAF24 24 VAC
- FA2S FSAF24-S 24 VAC w/Aux. Sw.

- FL12 FSLF120 120 VAC
- FL1S FSLF120-S 120 VAC w/Aux. Sw.
- FL24 FSLF24 24 VAC
- FL2S FSLF24-S 24 VAC w/Aux. Sw.
- GD1 GGD121 24 VAC
- GD2 GGD221 120 VAC
- MS4 MS4X09F 120 VAC
- MS4S MS4X09F 120 VAC w/MLS-300H
- MS8 MS8X09F 24 VAC
- MS8S MS8X09F 24 VAC w/MLS-300H
- N60 MN6105A1011 24 VAC
- N60S MN6105A1201 24 VAC w/Aux. Sw.
- N61 MN6110A1003 24 VAC
- N61S MN6110A1201 24 VAC w/Aux. Sw.
- N70 MN7505A2001 24 VAC
- N70S MN7505A2209 24 VAC w/Aux. Sw.
- N71 MN7510A2001 24 VAC
- N71S MN7510A2209 24 VAC w/Aux. Sw.
- N75 MN7520A2007 24 VAC
- N75S MN7520A2205 24 VAC w/Aux. Sw.
- S70 MS7505A2030 24 VAC
- S70S MS7505A2130 24 VAC w/Aux. Sw.
- S71 MS7510A2008 24 VAC
- S71S MS7510A2206 24 VAC w/Aux. Sw.
- S72 MS7520A2007 24 VAC
- S72S MS7520A2205 24 VAC w/Aux. Sw.

Pneumatic:

- 296 331-2961 25 psi
- 296P 331-2961PR 25 psi
- 306 331-3060 25 psi
- 306P 331-3060PR 24 V - 25 psi
- 482 331-4826 25 psi
- 482P 331-4826PR 24 V - 25 psi

Note:

1. Not all variants and options are available on all models. Refer to individual model for selection availability.

Options and Accessories

Nailor control dampers are available with a variety of options and accessories to suit the majority of commercial and light industrial applications and installations. With short lead times and marginal effect on costs, Nailor control dampers can be custom tailored to suit virtually any requirement.

MATERIAL OPTIONS:

OPTION CODE 304
STAINLESS STEEL CONSTRUCTION

1000/1100 Series

All parts of damper (except blade seals) will be constructed of 304 stainless steel. Provides higher corrosion resistance against harsh atmospheric and process elements. Consult your Nailor representative for specific application suitability.

OPTION CODE ALS
ALUMINUM CONSTRUCTION WITH
STAINLESS STEEL HARDWARE

2000 Series

Damper will be constructed with aluminum frame and blades with stainless steel linkage, bearings, axles and related hardware. Suitable for use in high humidity applications such as swimming pool areas etc.

OPTION CODE EAF
EXTRUDED ALUMINUM FRAME

2000 Series

Rugged Type 6063-T5 extruded aluminum frame for premium performance. See Models 2010-EAF/2020-EAF for further details.

OPTION CODE SSF
STAINLESS STEEL FRAME

2000 Series

Damper frame will be constructed from 304 stainless steel, fully welded with corner reinforcing brackets. Provides an extra rigid frame that is more corrosion resistant than galvanized steel.

BEARING OPTIONS:

OPTION CODE BC
CELCON® BEARINGS



Synthetic type Celcon® bearings provide long life and corrosion free operation. Standard bearing for all 1000 and 1800 series dampers.

OPTION CODE BO
OILITE® BRONZE BEARINGS



Bronze sintered (oil impregnated) self-lubricating oilite bearings provide long time lubrication making them ideal for use in applications where proper maintenance is uncertain or difficult.

OPTION CODE BS
STAINLESS STEEL BEARINGS



304 grade stainless steel bearings provide corrosion resistance in a wide variety of corrosive media. In higher heat applications, provides good oxidation resistance.

OPTION CODE BT
THRUST BEARINGS

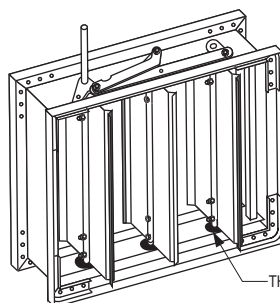

For use when damper is mounted with blades running vertically. Installed against lower blade edge to reduce friction due to weight of blades. When ordering, specify which side of damper will be bottom.

FLANGED FRAME OPTIONS:

Available as an option on Series 1000, 1100 and 2000 steel hat channel frame control dampers, the 1 1/2" (38) flanged frames allow for direct fastening to wall or unit housings as well as flanged ductwork. Damper inside dimension can be sized to match ductwork inside dimension, providing a smooth transition that produces lower pressure drop and less turbulence across the damper. Flange frames are also available with optional 9/32" (7) dia. bolt holes on 6" (152) centers for fast, convenient installation.

OPTION CODES

FF FLANGED FRONT
FFB FLANGED FRONT WITH BOLT HOLES

OPTION CODES

FR FLANGED REAR
FRB FLANGED REAR WITH BOLT HOLES

OPTION CODES

FD DOUBLE FLANGE
FDB DOUBLE FLANGE WITH BOLT HOLES

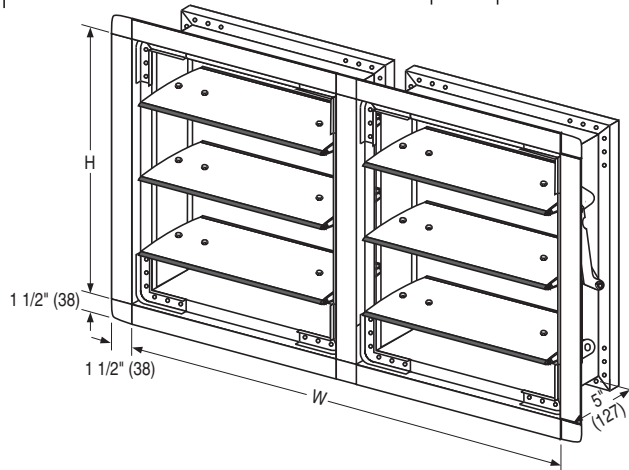
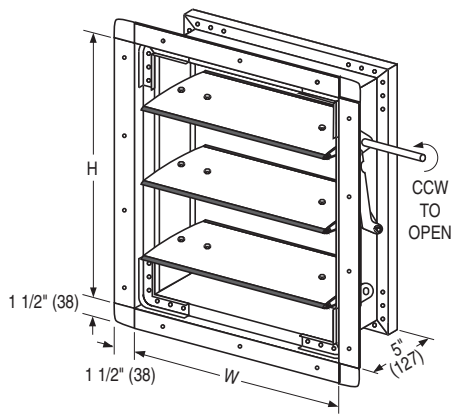
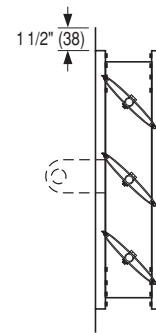
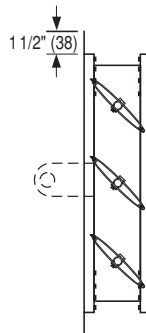
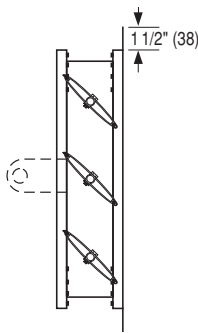

SINGLE SECTION DAMPER SHOWN WITH **FRB** OPTION: FLANGED REAR FRAME WITH 9/32" (7) DIA. BOLT HOLES ON 6" (152) CENTERS.

MULTIPLE SECTION DAMPER SHOWN WITH **FR** OPTION: FLANGED REAR FRAME (JACKSHAFT NOT SHOWN)

JAMB SEAL OPTIONS:

OPTION CODE JSM
METALLIC JAMB SEALS

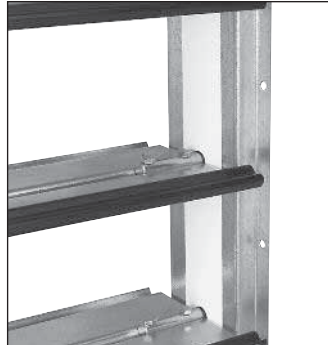

Standard compression type metallic jamb seal used for reducing air leakage between blade ends and frame. Standard jamb seals on Models 1010 and 1020.

OPTION CODE JSS
STAINLESS STEEL JAMB SEALS

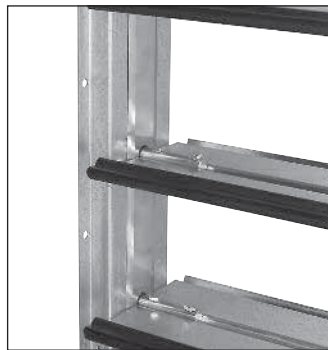

Compression type cambered stainless steel jamb seal for reducing air leakage between blade ends and frame. Provides higher resistance to corrosion and heat than our standard metallic jamb seal. Standard on Model Series 1100 and 2000 dampers.

ROUND/OVAL TRANSITIONS:

OPTION CODE CR
TRANSITION ENCLOSURE FOR ROUND DUCT.

OPTION CODE CO
TRANSITION ENCLOSURE FOR OVAL DUCT

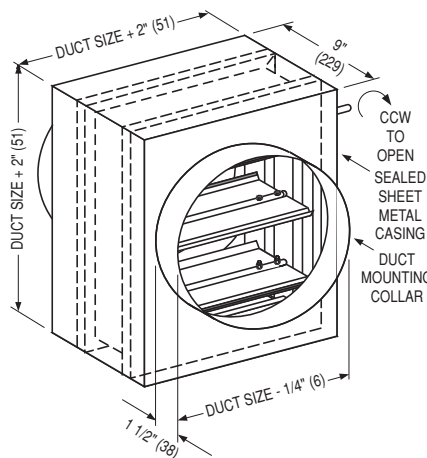

The CR transition enclosure option allows for connection of multi-blade control dampers to round ductwork. The CO transition enclosure option allows for connection of multi-blade control dampers to oval ductwork. Casing and collars are constructed from 20 ga. (1.0) galvanized steel (18 ga. (1.3) on sizes 36" x 36" (914 x 914) and up) and are tack welded and caulked against leakage.

MAXIMUM SIZE:

Single section: 46" (1168) dia.
For larger sizes contact factory.

TYPE CR (FOR ROUND DUCT) SHOWN

BLADE LINKAGE OPTION:

OPTION CODE **LF**
FACE LINKAGE

Nailor's robust plated steel linkage, uniquely installed directly to face of blades with integral heavy-duty brackets. Provides positive blade to blade connection while providing 'in the airstream' accessibility to linkage without removing damper from duct.

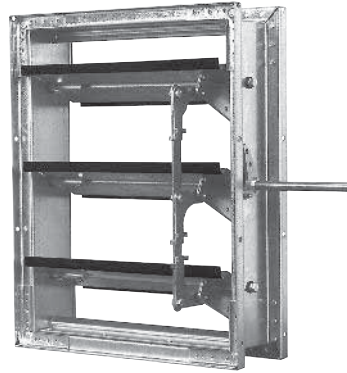

Model 1010 with Face Linkage (LF) option.

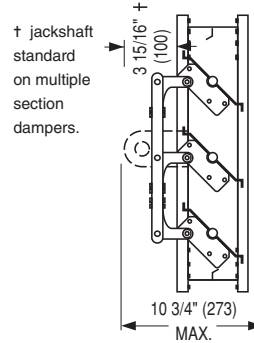

Parallel Blade
(Model 1010 Shown)

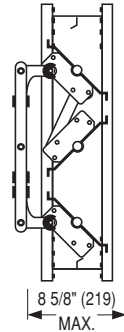

Opposed Blade
(Model 1020 Shown)

LINKAGE MATERIAL OPTIONS:

OPTION CODE **SSL**
STAINLESS STEEL LINKAGE

All linkage, axles and bearings will be of Type 304 Stainless Steel. Provides better resistance to corrosion and resistance to oxidation in higher heat applications.

OPTION CODE **SSA**
STAINLESS STEEL AXLES ONLY

Blade axles only will be of Type 304 Stainless Steel. Provides better resistance to corrosion and good resistance to oxidation in higher heat applications.

DRIVE SHAFT OPTION:

OPTION CODE **DLO**
LOCK-ON DRIVE SHAFT

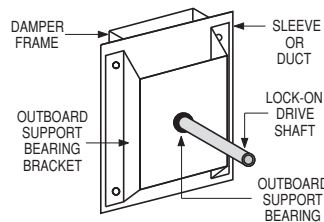

Shipped loose and can be installed before or after damper is mounted in duct. Unique spring clip locks shaft onto damper drive for firm connection. Each lock-on drive shaft is shipped complete with an outboard support bracket with bearing that can be fastened to outside of duct for extra support. Lock-on drive shafts are standard on dampers manufactured for Canada.

Note: **OPTION CODE DSR rigid drive shaft** (welded) is provided as standard on most control damper models. In Canada, **DSR** is available as an option.

BLADE SEAL OPTION:

OPTION CODE **BSP**
POLYURETHANE FOAM BLADE SEAL

FOR MODELS 1012 AND 1022 ONLY

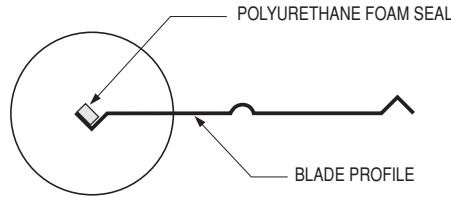

Available on Models 1012 and 1022 as an economical alternative to extruded seals, the polyurethane foam seal adheres to blade edge with self-adhesive backing. Suitable for light duty use in applications involving low static pressures and velocities.

MANUAL LOCKING QUADRANTS:

OPTION CODE **HLQ**
HAND LOCKING QUADRANT FOR
1/2" (13) DIA. DRIVES

FOR USE WITH 1/2" (13) DIA. DRIVE SHAFT

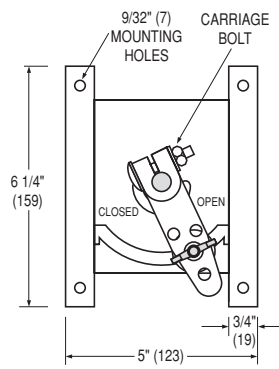

Standard hand locking quadrant designed for use with Model Series 1000, 1100, 1810/1820 and 2000 dampers. Supplied as standard with Celcon® bearing, the HLQ mounts directly over a 1/2" (13) dia. drive shaft and is secured to shaft with a carriage bolt. 16 ga. galvanized steel bracket with 1" (25) stand-off is provided for convenient installation that ensures the mounting screws do not interfere with any damper side linkage that may be hidden in damper frame. Quadrant handle and hardware are plated steel. A heavy-duty wing nut locks the quadrant in desired position.

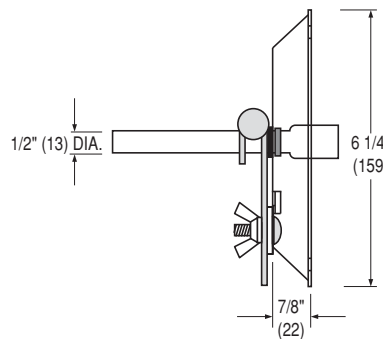

OPTION CODE **HL2**
HAND LOCKING QUADRANT WITH
2" (51) STAND-OFF

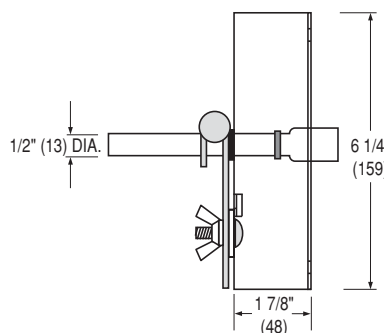

The HL2 hand locking quadrant is similar to the standard HLQ locking quadrant for use with 1/2" (13) dia. shafts (see above) but is supplied with a 2" (51) stand-off bracket that allows for use with externally insulated ductwork.

MANUAL LOCKING QUADRANTS:

OPTION CODE **HLQ**
HAND LOCKING QUADRANT FOR
1/4" (6) SQUARE DRIVES

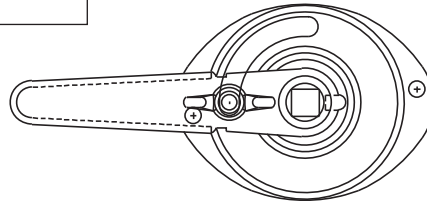

FOR USE WITH 1/4" (6) SQUARE DRIVE SHAFT

Suitable for light duty use on 1/4" (6) square drive shafts, this HLQ is supplied as standard on Models 1870 and 1890 balancing dampers. Constructed of plated steel, the quadrant slides directly over shaft and mounts easily with two mounting screws. A wing nut assembly locks the handle firmly in desired position.

OPTION CODE **SB**
HAND LOCKING QUADRANT WITH
2" (51) STAND-OFF BRACKET

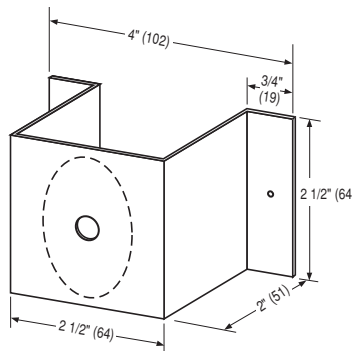

Option SB provides the above HLQ for 1/4" (6) square drive shafts with a 2" (51) stand-off bracket that allows the quadrant to be used on externally insulated ductwork.

(QUADRANT NOT SHOWN)

MANUAL PULL-CHAIN OPERATORS:

OPTION CODE **PCE**
EXTERNAL CHAIN OPERATOR

OPTION CODE **PCI**
INTERNAL CHAIN OPERATOR

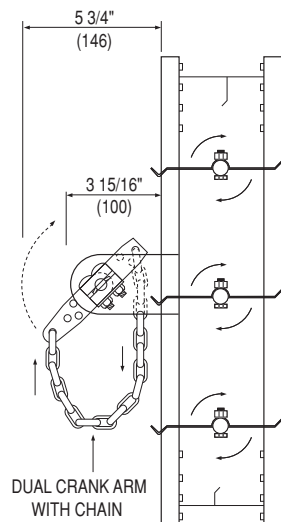

Nailor's manual pull-chain operator is ideal for use in applications that require remote manual operation from below a damper that is otherwise generally inaccessible. Suitable for use on Series 1000, 1100, and 2000 dampers.

Option PCE External Pull Chain Operator provides a dual crank arm type linkage securely fastened to a rugged jackshaft that extends past the damper frame (out of airstream). Operator can be adapted for right or left handed drive (right hand drive standard).

Option PCI Internal Pull Chain Operator provides the same strong linkage and jackshaft mounted within the face of the damper (in airstream). Units come complete with strong closed loop steel chain (please specify length) that loops down for convenient two-way operation and can be fastened to wall to maintain damper blade position. Both PCE and PCI options provide firm, smooth operation of dampers that are above the rest!

JACKSHAFTS AND ACCESSORIES:

OPTION CODE JK5
1/2" (13) DIA. JACKSHAFT

OPTION CODE JK1
1" (25) DIA. JACKSHAFT

JK5 and **JK1** jackshafting may be ordered as an option on Series 1000, 1100 and 2000 single section dampers in order to offset the mounting position of an external actuator (ie: for mounting of damper within a wall) or for internal factory mounting of an actuator (in the airstream).

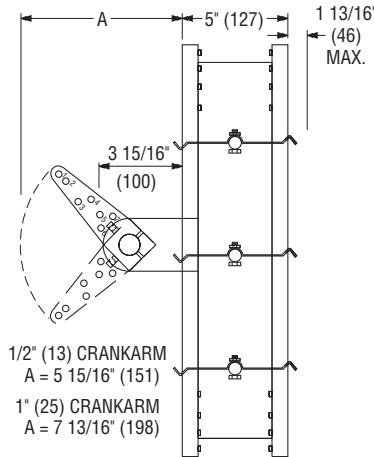

TYPICAL JACKSHAFT



**MODEL 2020 SHOWN WITH
OPTIONAL JK1 JACKSHAFT
AND 1" (25) DIA. CRANK ARM**

OPTIONAL CRANK ARM DETAILS:

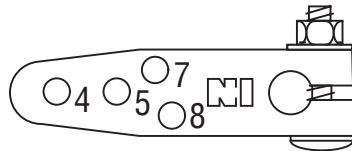

1/2" (13) DIA. CRANK ARM PART NO. CD005

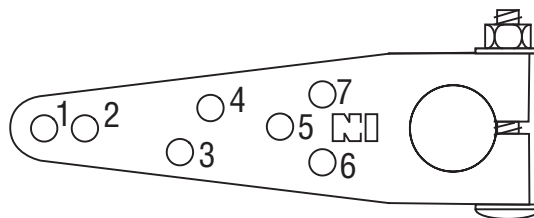

1" (25) DIA. CRANK ARM PART NO. CD010

Hole No.	Crank Arm Radius
8	1 3/8" (35)
7	1 9/16" (40)
6	1 9/16" (40)
5	2" (51)
4	2 13/16" (72)
3	3 3/16" (81)
2	4 1/4" (108)
1	4 3/4" (121)

Other **drive accessories** such as Swivel for 5/16" (8) dia. Rod (Part No. CD006) and 1" to 3/4" (25 to 19) Jackshaft Reducer (Part No. CD075) are available. Contact your Nailor representative for assistance.

VERTICAL INTERCONNECTION OF DAMPER SECTIONS:

OPTION CODE **VCK**
VERTICAL INTERCONNECTION KIT

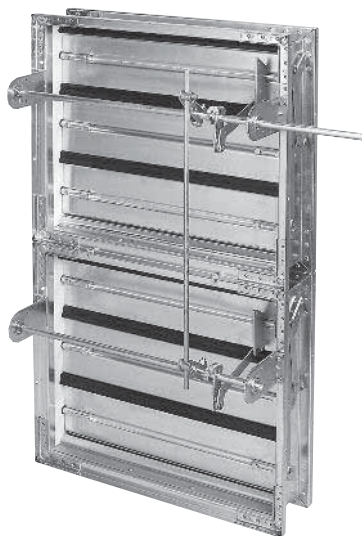

Nailor 1000, 1100 and 2000 Series control dampers that are two sections in height (single section wide) can be connected together for operation by a single actuator by utilizing **Option VCK Vertical Inter-Connection Kit**. Standard kit consists of factory mounted 1/2" (13) diameter jackshafts on each section, with crankarms, swivels and 5/16" (8) diameter connecting rod for smooth, positive operation. Specify drive location when ordering.

SLEEVE OPTIONS:

OPTION CODE **SL**
SLEEVE

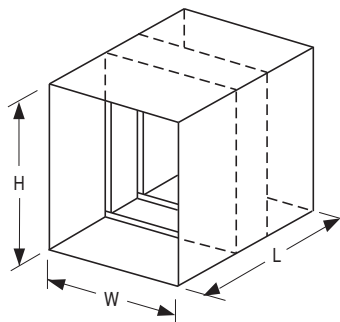

TYPE 'A'
BLADES AND FRAME IN AIRSTREAM

Nailor control dampers are available in factory furnished sleeves in lengths up to 36" (914). Sleeves are constructed out of 20 ga. through 10 ga. (1.0 through 3.5) galvanized steel. When dampers are installed in factory sleeves, the "L" dimension specifies the location of damper within the sleeve. Factory furnished sleeves ensure proper fit and allow for direct shipment of dampers to jobsite eliminating the need for costly shop handling and provide for convenient, fast installation. Standard sleeve length is 12" (305) and standard "L" dimension is 4" (102).

FACE & BYPASS MIXING DAMPERS:

OPTION CODE **FBV**
VERTICAL

OPTION CODE **FBH**
HORIZONTAL

OPTION CODE **FBR**
RIGHT ANGLE

Face and bypass dampers are standard control dampers assembled either (FBV) one over the other, (FBH) beside each other or (FBR) at right angle from each other. The units are interconnected for simultaneous blade action, typically causing one damper to open while the other closes. The Nailor FBR option utilizes an inter-connected linkage that eliminates ball joints, crank arms and connecting rods with no adjustment required. The top section is fully open when the bottom section is fully closed.

Dampers larger than maximum single section sizes are assembled of equal single section dampers (refer to the damper submittal document for maximum section sizes) and may be coupled for operation in a variety of ways. Large multiple section damper assemblies require an engineering analysis of how the dampers are to be operated (type, quantity and location of actuators) before the best method of coupling sections can be determined. Special assembly drawings are normally prepared and forwarded for customer approval on large damper assemblies.

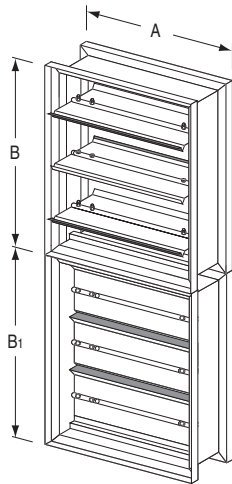

FBV
VERTICAL

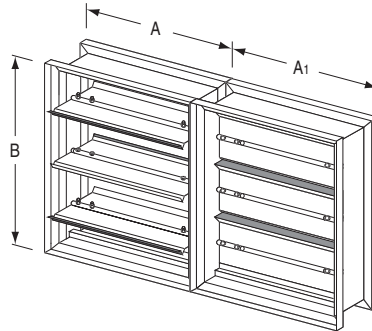

FBH
HORIZONTAL

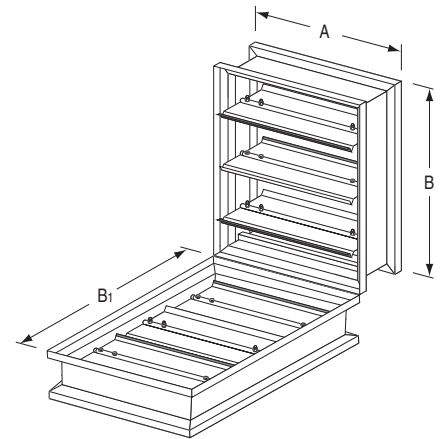

FBR
RIGHT ANGLE

B
CONTROL DAMPERS

TAKE CONTROL OF PERFORMANCE:

LOUVER/DAMPER COMBINATIONS IN A COMMON SLEEVE

Since 1971, Nailor Industries has been a global leader in the engineering and manufacturing of Air Control products. Our Control Damper product line features some of the industry's best performing products, with a reputation for reliability and affordability. Our Louver product line features a growing number of aesthetically pleasing and mechanically enduring models, proven to perform under the most demanding conditions.

Our capabilities as a world class manufacturer allow for an endless possibility of Control Damper and Louver combinations, suitable for just about any application or installation requirement. Using the skilled craftsmanship of Nailor's Sheet Metal Workers International Association (S.M.W.I.A) manufacturing personnel, we can construct and ship, a wide variety of Control Damper and Louver combinations, mounted in a common sleeve, ready for a fast and easy field installation. This option reduces field labor costs, materials costs, and shipping & handling costs, and offers an out of the box solution from our factory to your job site! In addition, factory mounted actuators assures proper installation and actuator selection, further reducing installation and handling costs.

B CONTROL DAMPERS

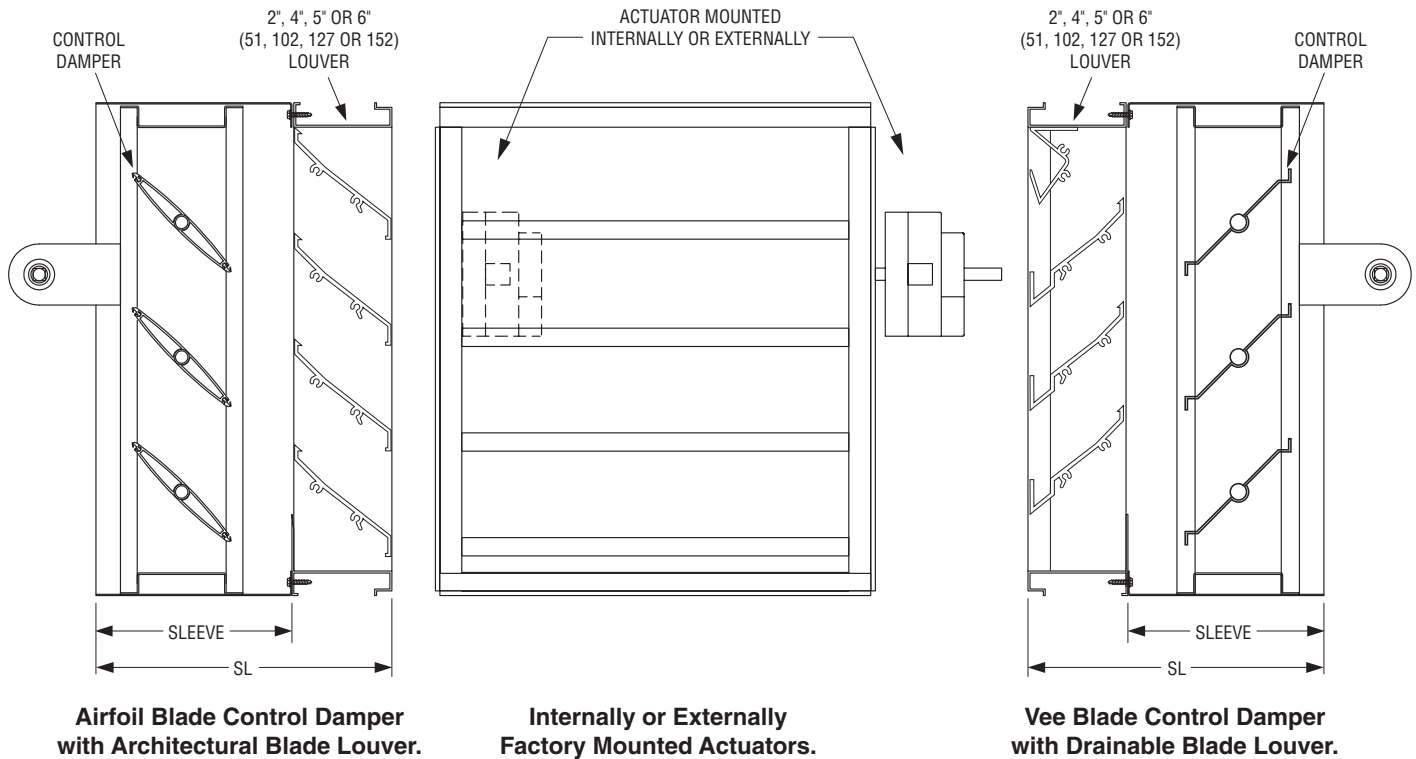

Consult Nailor for specific applications and performance requirements for a custom solution today!

STANDARD MULTIPLE SECTION CONTROL DAMPER DRIVE ARRANGEMENTS:

Maximum single section size is 48" wide x 72" high (1219 x 1829) for all models except 2000 series which is 60" wide x 72" high (1524 x 1829). Dampers larger than the maximum single section size are fabricated in multiple section assemblies. These assemblies consist of sections of equal size which are coupled together with a jackshaft. The jackshaft runs parallel to the "W" dimension. Maximum Section Size for all Multiple Section Dampers is 48" wide x 72" high (1219 x 1829).

A. 1/2" (13) Diameter Jackshaft:

- Used on two sections wide with a maximum of 32 sq. ft. with blade and jamb seals; or a maximum of 40 sq. ft. without seals.

B. 1" (25) Diameter Jackshaft:

- Used on two sections wide over 32 sq. ft. with blade and jamb seals; or over 40 sq. ft. without seals.

- Used on assemblies of more than two sections wide, regardless of area.

Use the details on page B50 and B51 to determine how multiple section dampers with standard construction and sizes up to 240" wide x 144" high (6086 x 3658) will be manufactured. Details do not apply if the control damper has any of the following non-standard features such as unequal section sizes or Face and Bypass arrangement. For sizes larger than 240" x 144" (6096 x 3658), consult factory.

HOW TO DETERMINE YOUR DAMPER CONFIGURATION

1. Calculate the damper area in square feet:

$$\text{Area} = \frac{(\text{W in. wide} \times \text{H in. high})}{144} = \text{_____ sq. ft.}$$

2. Based on the W and H dimensions and the area of your damper, determine the appropriate assembly detail using the chart on page B50.

Example: Model 1020, 96" wide x 96" high.

$$\text{Area} = \frac{(96 \times 96)}{144} = 64 \text{ sq. ft.}$$

From chart and drawings, damper configuration is per detail 22Q. Your damper will be built this way.

Multiple section assemblies require bracing to support the weight of the assembly and to hold against system pressure. Appropriate bracing must support the damper horizontally at least once for every 8 ft. (2438) of damper width. Vertical assemblies and higher system pressures require more bracing.

The maximum shipping size is 96" x 72" (2438 x 1829) or two sections wide. Larger units are shipped in sections for field assembly. Refer to the Control Damper Installation Instructions on pages B50 and B51 for joining multiple sections.

Dimension W Width in inches (mm)							
Dimension "H" Height in inches (mm) ↓	All Model Series	1000 and 1100 Series Only	2000 Series Only		All Model Series		
	48" (1219) and under	Over 48" (1219) Thru 96" (2438)	Over 48" (1219) Thru 60" (1524)	Over 60" (1524) Thru 96" (2438)	Over 96" (2438) Thru 144" (3658)	Over 144" (3658) Thru 192" (4877)	Over 192" (4877) Thru 240" (6069)
72" (1829) and under	-	Detail 21 S or D	-	Detail 21 S or D	Detail 31 S or D	Detail 41 S or D	Detail 51 S or D
Over 72" (1829) Thru 144" (3658)	Detail 12 S or D	Detail 22 S, D or Q	Detail 22 S, D or Q		Detail 32 D or Q	Detail 42 D or Q	Detail 52 S or D

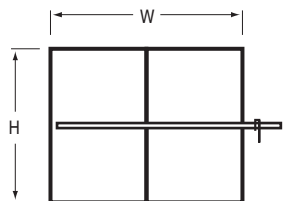

DETAIL 21S
25 SQ. FT. (2.3 SQ. M) AND UNDER WITH SEALS
48 SQ. FT. (4.5 SQ. M) AND UNDER NO SEALS

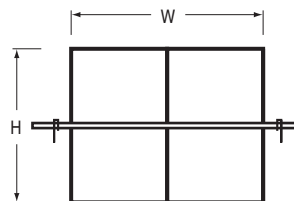

DETAIL 21D
OVER 25 THRU 48 SQ. FT. (OVER 2.3 THRU 4.5 SQ. M) WITH SEALS

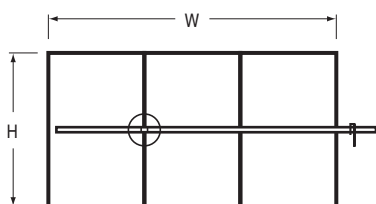

DETAIL 31S
25 SQ. FT. (2.3 SQ. M) AND UNDER WITH SEALS
50 SQ. FT. (4.6 SQ. M) AND UNDER NO SEALS

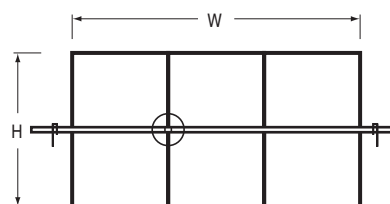

DETAIL 31D
OVER 25 THRU 50 SQ. FT. (OVER 2.3 THRU 4.6 SQ. M) WITH SEALS
OVER 50 THRU 72 SQ. FT. (OVER 4.6 THRU 6.7 SQ. M) NO SEALS

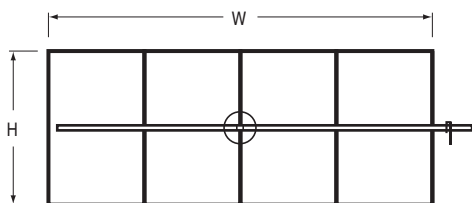

DETAIL 41S
25 SQ. FT. (2.3 SQ. M) AND UNDER WITH SEALS
50 SQ. FT. (4.6 SQ. M) AND UNDER NO SEALS

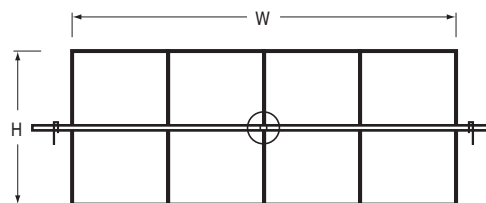

DETAIL 41D
OVER 25 THRU 96 SQ. FT. (OVER 2.3 THRU 8.9 SQ. M) WITH SEALS
OVER 50 THRU 96 SQ. FT. (OVER 4.6 THRU 8.9 SQ. M) NO SEALS

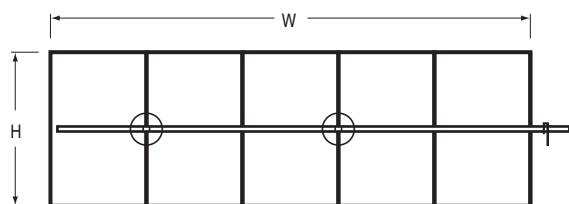

DETAIL 51S
25 SQ. FT. (2.3 SQ. M) AND UNDER WITH SEALS
50 SQ. FT. (4.6 SQ. M) AND UNDER NO SEALS

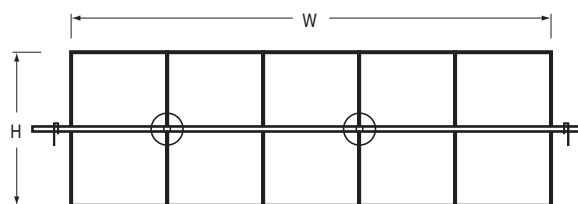

DETAIL 51D
OVER 25 THRU 120 SQ. FT. (OVER 2.3 THRU 11.1 SQ. M) WITH SEALS
OVER 50 THRU 120 SQ. FT. (OVER 4.6 THRU 11.1 SQ. M) NO SEALS

NOTE: INDICATES LOCATION OF JACKSHAFT COUPLING.

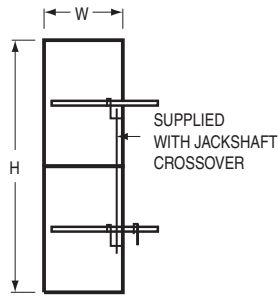

DETAIL 12S
25 SQ. FT. (2.3 SQ. M) AND UNDER WITH SEALS
48 SQ. FT. (4.5 SQ. M) AND UNDER NO SEALS

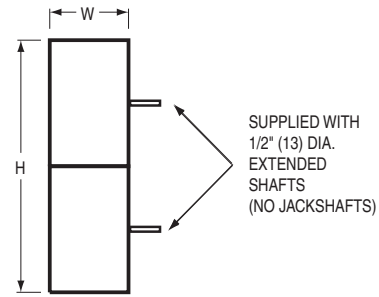

DETAIL 12D
OVER 25 THRU 48 SQ. FT. (OVER 2.3 THRU 4.5 SQ. M) WITH SEALS

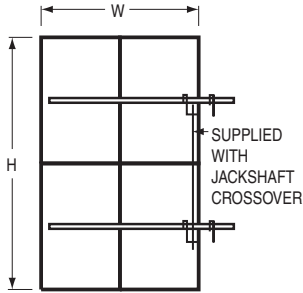

DETAIL 22S
OVER 24 THRU 25 SQ. FT. (OVER 2.2 THRU 2.3 SQ. M) WITH SEALS
OVER 24 THRU 50 SQ. FT. (OVER 2.2 THRU 4.6 SQ. M) NO SEALS

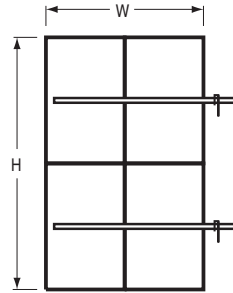

DETAIL 22D
OVER 25 THRU 50 SQ. FT. (OVER 2.3 THRU 4.6 SQ. M) WITH SEALS
OVER 50 THRU 96 SQ. FT. (OVER 4.6 THRU 8.9 SQ. M) NO SEALS

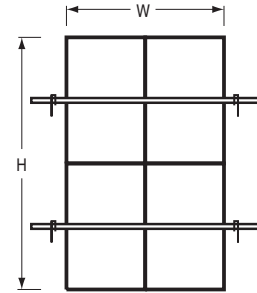

DETAIL 22Q
OVER 50 THRU 96 SQ. FT. (OVER 4.6 THRU 8.9 SQ. M) WITH SEALS

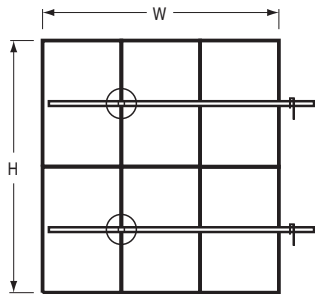

DETAIL 32D
OVER 48 THRU 50 SQ. FT. (OVER 4.5 THRU 4.6 SQ. M) WITH SEALS
OVER 48 THRU 100 SQ. FT. (OVER 4.5 THRU 9.3 SQ. M) NO SEALS

NOTE: INDICATES LOCATION OF JACKSHAFT COUPLING.

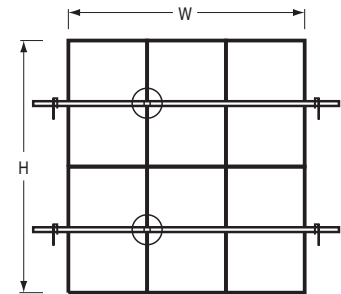

DETAIL 32Q
OVER 50 THRU 144 SQ. FT. (OVER 4.6 THRU 13.4 SQ. M) WITH SEALS
OVER 100 THRU 144 SQ. FT. (OVER 9.3 THRU 13.4 SQ. M) NO SEALS

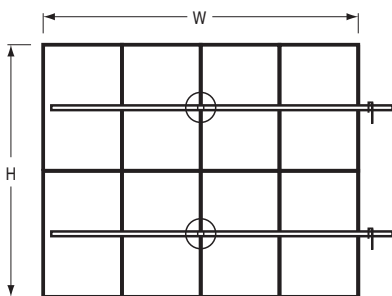

DETAIL 42D
OVER 72 THRU 100 SQ. FT. (OVER 6.7 THRU 9.3 SQ. M) NO SEALS

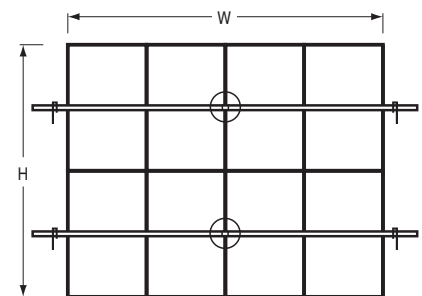

DETAIL 42Q
OVER 72 THRU 192 SQ. FT. (OVER 6.7 THRU 17.8 SQ. M) WITH SEALS
OVER 100 THRU 192 SQ. FT. (OVER 9.3 THRU 17.8 SQ. M) NO SEALS

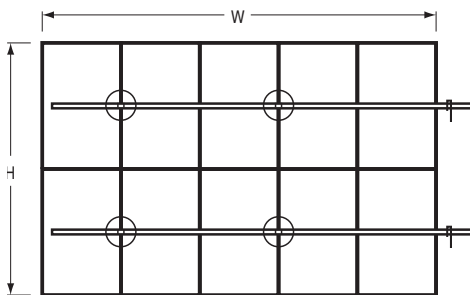

DETAIL 52D
OVER 96 THRU 100 SQ. FT. (OVER 8.9 THRU 9.3 SQ. M) NO SEALS

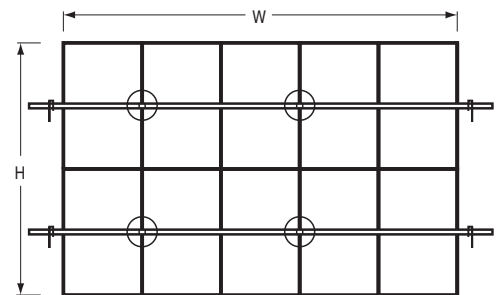

DETAIL 52Q
OVER 96 THRU 240 SQ. FT. (OVER 8.9 THRU 22.3 SQ. M) WITH SEALS
OVER 100 THRU 240 SQ. FT. (OVER 9.3 THRU 22.3 SQ. M) NO SEALS