

MODEL 1221-DOW (1 1/2 HR.)

AIRFOIL BLADE • OUT OF WALL DUCTED BOTH SIDES

The Model 1221-DOW combination fire/smoke damper is specially designed for “out of wall” (vertical mount) or “out of floor” (horizontal mount) through penetration applications (ductwork is connected to both sides) where the damper cannot be installed within the plane of the wall or floor. It is ideal for applications where building codes require both a fire damper for the protection of ductwork penetrations in walls or floors that have a fire resistance rating of up to 2 hours and also require a leakage rated damper for operational smoke control in static or dynamic smoke management systems.



Model 1221-DOW



Model 1221-OW

MODEL 1221-OW (1 1/2 HR.)

AIRFOIL BLADE • OUT OF WALL GRILLE MOUNT

Model 1221-OW is an “out of wall” high performance combination fire/smoke damper specifically designed for supply or return ducts that terminate at a grille. The design allows for through the grille access to the damper, actuator and other components. It features Nailor’s unique inter-locking double skin airfoil blade design that eliminates combustible seals and provides flame and smoke seal under fire conditions at temperatures up to 2000°F (1093°C)!

MODEL SERIES 1221C (1 HR. AND 1 1/2 HR.)

TUNNEL CORRIDOR DAMPER

AIRFOIL BLADE

Models 1221C-1 and 1221C-2 Airfoil Blade Tunnel Corridor Combination Fire/Smoke Dampers are for use where ductwork penetrates the ceiling of an interior corridor of a building, creating a horizontal opening that requires protection. Model 1221C-1 is suitable for use with a steel grille or diffuser when the duct terminates at the ceiling. Model 1221C-2 is suitable for use when the duct is required to continue down past the ceiling level. Each unit is supplied factory mounted in a suitable sleeve complete with upper retaining angles. Model 1221C-3 is both a 1 hr. rated Corridor Damper for use in corridor ceilings and a standard 1 1/2 hr. rated Combination Fire/Smoke Damper for use in walls and floors. The dual rating makes it ideal for stocking as the unit can be supplied when either type of damper is required by the local customer.



Model 1221C-1



Model 1271C-1

MODEL SERIES 1271C (1 HR. AND 1 1/2 HR.)

TUNNEL CORRIDOR DAMPER

VEE GROOVE BLADE

Models 1271C-1 and 1271C-2 Tunnel Corridor Combination Fire/Smoke Dampers are for use where ductwork penetrates the ceiling of an interior corridor of a building, creating a horizontal opening that requires protection. Model 1271C-1 is suitable for use with a steel grille or diffuser when the duct terminates at the ceiling. Model 1271C-2 is suitable for use when the duct is required to continue down past the ceiling level. Each unit is supplied factory mounted in a suitable sleeve complete with upper retaining angles. Model 1271C-3 is both a 1 hr. rated corridor damper for use in corridor ceilings and a standard 1 1/2 hr. rated combination fire/smoke damper for use in walls and floors. The dual rating makes it ideal for stocking as the unit can be supplied when either type of damper is required by the local customer.

WHEN IT COMES TO FIRE/SMOKE DAMPERS, NAILOR'S 1220 SERIES 'THE WALL' PROVIDES THE ULTIMATE CLOSURE!

'THE WALL' PRINCIPLE:

Most fire/smoke damper manufacturers commonly incorporate a synthetic blade-to-blade seal in order to maintain their leakage class under elevated temperature conditions – the smoke control mode.

The weakness in using a synthetic blade seal is that when the damper is subjected to fire conditions, these combustible seals burn out, allowing significant leakage! In fact, UL 555 Standard permits gaps between the damper blades of up to 3/4" (19) during the fire test, thus allowing significant quantities of smoke to pass through a closed damper under fire conditions.

Nailor's Model Series 1220 and 1220-3, known as "The Wall", provides an innovative inter-locking double-skin airfoil blade which eliminates the need for blade seals and maintains a complete barrier throughout the fire test with absolutely no visible gaps.

When this design was tested to ISO Standard 10294-1, it maintained its cold leakage rating throughout a 4 hour fire test at temperatures up to 2000°F (1093°C)!

Amazingly, "The Wall" gets tighter as it gets hotter!

The 1220 and 1220-3 Series Dampers are ideal for applications where building codes require both a fire damper for the protection of ductwork penetrations in walls or floors that have a fire resistance rating of up to 4 hours and also require a leakage rated damper for operational smoke control in static or dynamic smoke management systems.

The 1220 and 1220-3 Series have been designed and tested to offer premium performance with the lowest leakage class available and a low pressure drop well suited to the majority of commercial applications.



THE LARGEST UL LISTING IN THE INDUSTRY!

Photograph of actual UL 555 fire test conducted successfully at Underwriters Laboratories Inc., Northbrook Illinois. The largest multi-blade fire damper listing established to date.

FEATURES:

- Airfoil blade, double-skin design, provides extremely low pressure drop for optimal system performance.
- Unique interlocking blade design eliminates the need for combustible synthetic blade seals, maintaining leakage class under fire conditions.
- Largest UL listing in the industry at 96 sq. ft. (8.9 sq. m) eliminates the need for costly mullions in most applications.
- Heat responsive device provides controlled closure by the actuator, eliminating instantaneous damper closure that can damage ductwork.
- Out of airstream linkage is maintenance free and prevents unwanted turbulence and noise.
- Each blade includes "no-slip" double bolting onto the axle to provide positive locking connection.
- Rugged hat channel frame design is reinforced with die-formed corner gussets for superior strength.

OPTIONS:

- Factory supplied sleeve: Available from 10 to 20 ga. (3.5 to 1.0) and in various lengths to suit wall/floor thickness. Sleeve and damper are caulked at the factory to help ensure field compliance with UL installation requirements and to meet UL leakage performance. Standard sleeve is 16" x 20 ga. (406 x 1.0) for dampers up to 84" (2134) in width and 18 ga. (1.2) for wider assemblies in accordance with SMACNA requirements for duct construction.
- A comprehensive range of UL qualified electric or pneumatic actuators.
- MLS-300 Position Indicator Switchpack: Provides the ability to remotely indicate damper blade position.
- DTO Dual Temperature Override Sensor (MLS-400): A reopenable control system which provides the ability to override fire induced closure from a remote fire control station and permit controlled operation in a dynamic smoke management system.
- 'Quick-set' Retaining Angles: Completes the installation package. Sized to fit and shipped with each damper.

- UL 555 CLASSIFIED CORRIDOR DAMPER
- UL 555S CLASSIFIED SMOKE DAMPER
- TUNNEL CORRIDOR COMBINATION FIRE/SMOKE DAMPER
- HIGH PERFORMANCE



Model 1221C-1

Models:

1221C-1 1 Hour Label - For use with Steel Grille/Diffuser

1221C-2 1 Hour Label - For Ducted Installation

Nailor Models 1221C-1 and 1221C-2 Corridor Dampers are for use where ductwork penetrates the ceiling of an interior corridor of a building, creating a horizontal opening that requires protection. Unique interlocking airfoil blade design provides low pressure drop and ultra-low leakage without the use of blade seals that can burn-off during fire conditions. Model 1221C-1 is suitable for use with a steel grille or diffuser when the duct terminates at the ceiling. Model 1221C-2 is suitable for use when the duct is required to continue down past the ceiling level. Each unit is supplied factory mounted in a suitable sleeve complete with upper retaining angles. For applications where the duct terminates at the ceiling, other manufacturers require full length lower retaining angles with minimum 1" (25) ceiling overlap that protrudes past the grille/diffuser frame causing aesthetic difficulties. Model 1221C-1 is provided with lower mounting tabs that are easily covered by available variety of Nailor steel grilles/diffusers, solving this problem. For Model 1221C-2, lower retaining angles are available from Nailor. Either way, Nailor provides complete protection with reduced installation time and cost.

Model 1221C-1:

STANDARD CONSTRUCTION:

- Frame:** 5" x 7/8" x 16 ga. (127 x 22 x 1.6) galvanized steel hat channel.
- Blades:** 14 ga. (2.0) equivalent galvanized steel formed airfoil on 5 1/2" (140) centers. Opposed action.
- Sleeve:** 16" x 20 ga. (406 x 1.0) standard.
- Upper Retaining Angles:** 1 1/2" x 1 1/2" x 16 ga. (38 x 38 x 1.6) galv. steel (by Nailor).
- Linkage:** Concealed in frame. 12 ga. (2.7) plated steel.
- Bearings:** 1/2" (13) dia. self-lubricating oilite bronze.
- Axles:** 1/2" (13) dia. plated steel double bolted to blades.
- Jackshaft:** 1/2" (13) dia. cadmium plated steel.
- Jamb Seals:** Cambered stainless steel.

Heat Responsive Device (Controlled Closure):

ERL (Electric Resettable Link) is standard on dampers with electric actuators: 250°F (121°C) std. 165°F (74°C), 212°F (100°C) and 350°F (177°C) available. PRL (Pneumatic Replaceable Link) is standard on dampers with pneumatic actuators: 212°F (100°C) standard. 165°F (74°C) and 280°F (138°C) available.

DIMENSIONAL DATA:

Model 1221C-1 Sizes (Duct W x H):

Minimum	Maximum
8" x 8" (203 x 203)	24" x 24" (610 x 610)

COMMON OPTIONS:

- DTS Damper Test Switch for cycle testing.
- DTO Dual Temperature Override Sensor (MLS-400).
- MLS-300 Position Indicator Switch Pack.
- Factory fitted sleeves in custom lengths, gauges and transition styles.

QUALIFICATIONS:

- UL 555 CLASSIFIED CORRIDOR DAMPER, 1 hr. Fire Resistance Rating (File # R9492).
- UL 555S CLASSIFIED SMOKE DAMPER, Leakage Class I at 250°F or 350°F elevated temperature (File # R9492).
- Meets the requirements of NFPA 90A, NFPA 92 for Fire/Smoke Dampers.
- California State Fire Marshal: Fire Damper Listing No. 3225-0935:0106.
- Meets the requirements of City of Los Angeles, Uniform Building Code.
- Maximum velocity: 2000 fpm @ 4" w.g. (10 m/s @ 1 kPa).

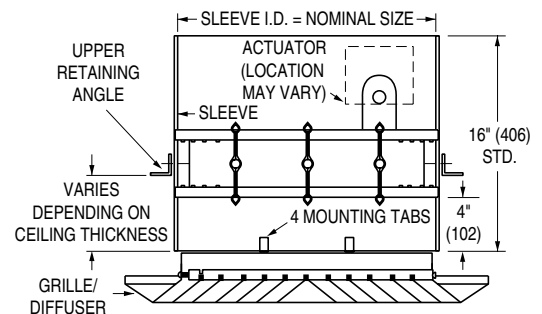

MODEL 1221C-1 (for use with Steel Grille/Diffuser)

Model 1221C-2:

STANDARD CONSTRUCTION:

- Frame:** 5" x 7/8" x 16 ga. (127 x 22 x 1.6) galvanized steel hat channel.
- Blades:** 14 ga. (2.0) equivalent galvanized steel formed airfoil on 5 1/2" (140) centers. Opposed action.
- Sleeve:** 16" x 20 ga. (406 x 1.0) standard.
- Upper Retaining Angles:** 1 1/2" x 1 1/2" x 16 ga. (38 x 38 x 1.6) galv. steel (by Nailor).
- Lower Retaining Angles:** 1 1/2" x 1 1/2" x 16 ga. (38 x 38 x 1.6) galvanized steel by installing contractor (optionally by Nailor).
- Linkage:** Concealed in frame. 12 ga. (2.7) plated steel.
- Bearings:** 1/2" (13) dia. self-lubricating oilite bronze.
- Axles:** 1/2" (13) dia. plated steel double bolted to blades.
- Jackshaft:** 1/2" (13) dia. cadmium plated steel.
- Jamb Seals:** Cambered stainless steel.

Heat Responsive Device (Controlled Closure):

ERL (Electric Resettable Link) is standard on dampers with electric actuators: 250°F (121°C) standard. 165°F (74°C), 212°F (100°C) and 350°F (177°C) available. PRL (Pneumatic Replaceable Link) is standard on dampers with pneumatic actuators: 212°F (100°C) standard. 165°F (74°C) and 280°F (138°C) available.

DIMENSIONAL DATA:

Model 1221C-2 Sizes (Duct W x H):

Minimum	Maximum
8" x 8" (203 x 203)	24" x 24" (610 x 610)

COMMON OPTIONS:

- DTS Damper Test Switch for cycle testing.
- DTO Dual Temperature Override Sensor (MLS-400).
- MLS-300 Position Indicator Switch Pack.
- Factory fitted sleeves in custom lengths, gauges and transition styles.

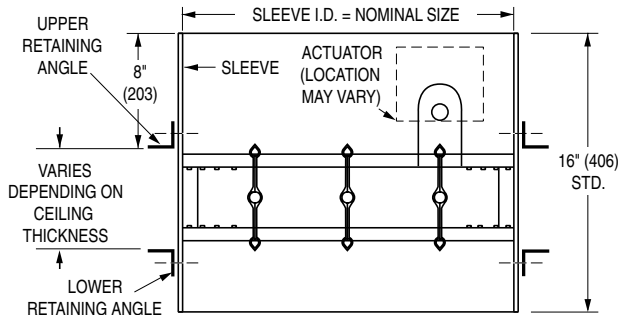

MODEL 1221C-2

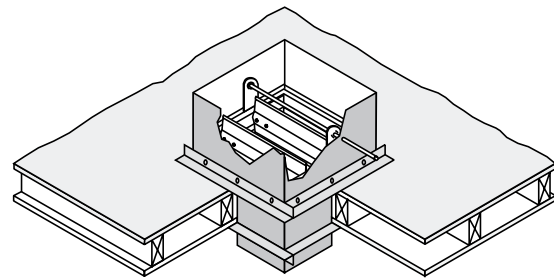

Isometric View of typical Model 1221C-2 in 1 hr. wood stud ceiling

QUALIFICATIONS:

- **UL 555 CLASSIFIED CORRIDOR DAMPER, 1 hr. Fire Resistance Rating (File # R9492).**
- **UL 555S CLASSIFIED SMOKE DAMPER, Leakage Class I at 250°F or 350°F elevated temperature (File # R9492).**
- **Meets the requirements of NFPA 90A, NFPA 92 for Fire/Smoke Dampers.**
- **California State Fire Marshal: Fire Damper Listing No. 3225-0935:0106.**
- **Meets the requirements of City of Los Angeles, Uniform Building Code.**
- **Maximum velocity: 2000 fpm @ 4" w.g. (10 m/s @ 1 kPa).**

- DUAL USAGE COMBINATION FIRE/SMOKE DAMPER
- UL 555 CLASSIFIED CORRIDOR DAMPER
- UL 555 CLASSIFIED FIRE DAMPER
- UL 555S CLASSIFIED SMOKE DAMPER



Model 1221C-3

Model:
1221C-3 1 Hour Label & 1 1/2 Hour Label

Nailor Model 1221C-3 is both a 1 hr. rated corridor damper for use in corridor ceilings and a standard 1 1/2 hr. rated combination fire/smoke damper for use in walls and floors. The dual rating makes it ideal for stocking as the unit can be supplied when either type of damper is required by the local customer. Model 1221C-3 is supplied complete with upper retaining angles as well as mounting tabs for use with a steel grille/diffuser. The damper may be installed using the single-side retaining angles method. Lower retaining angles are available for ducted corridor or standard wall/floor combination fire/smoke applications when the two-sided angles installation is utilized.

STANDARD CONSTRUCTION:

- Frame:** 5" x 7/8" x 16 ga. (127 x 22 x 1.6) galvanized steel hat channel.
- Blades:** 14 ga. (2.0) equivalent galvanized steel formed airfoil on 5 1/2" (140) centers. Opposed action.
- Sleeve:** 16" x 20 ga. (406 x 1.0) standard.
- Upper Retaining Angles:** 1 1/2" x 1 1/2" x 16 ga. (38 x 38 x 1.6) galv. steel (byNailor).
- Lower Retaining Angles:** 1 1/2" x 1 1/2" x 16 ga. (38 x 38 x 1.6) galvanized steel by installing contractor (optionally by Nailor).
- Linkage:** Concealed in frame. 12 ga. (2.7) plated steel.
- Bearings:** 1/2" (13) dia. self-lubricating oilite bronze.
- Axles:** 1/2" (13) dia. plated steel double bolted to blades.
- Jackshaft:** 1/2" (13) dia. cadmium plated steel.
- Jamb Seals:** Cambered stainless steel.

QUALIFICATIONS:

- **UL 555 CLASSIFIED CORRIDOR DAMPER, 1 hr. Fire Resistance Rating (File # R9492).**
- **UL 555 CLASSIFIED FIRE DAMPER, 1 1/2 hr. Fire Resistance Rating (File # R9492).**
- **UL 555S CLASSIFIED SMOKE DAMPER, Leakage Class I at 250°F or 350°F elevated temperature (File # R9492).**
- **Meets the requirements of NFPA 90A, NFPA 92 for Fire/Smoke Dampers.**
- **California State Fire Marshal: Fire Damper Listing No. 3225-0935:0106.**
- **Meets the requirements of City of Los Angeles, Uniform Building Code.**
- **Maximum velocity: 2000 fpm @ 4" w.g. (10 m/s @ 1 kPa).**

Heat Responsive Device (Controlled Closure):

ERL (Electric Resettable Link) is standard on dampers with electric actuators: 250°F (121°C) standard. 165°F (74°C), 212°F (100°C) and 350°F (177°C) available.

PRL (Pneumatic Replaceable Link) is standard on dampers with pneumatic actuators: 212°F (100°C) standard. 165°F (74°C) and 280°F (138°C) available.

DIMENSIONAL DATA:

Model 1221C-3 Sizes (Duct W x H):

Minimum	Maximum
8" x 8" (203 x 203)	24" x 24" (610 x 610)

COMMON OPTIONS:

- DTS Damper Test Switch for cycle testing.
- DTO Dual Temperature Override Sensor (MLS-400).
- MLS-300 Position Indicator Switch Pack.
- Factory fitted sleeves in custom lengths, gauges and transition styles.

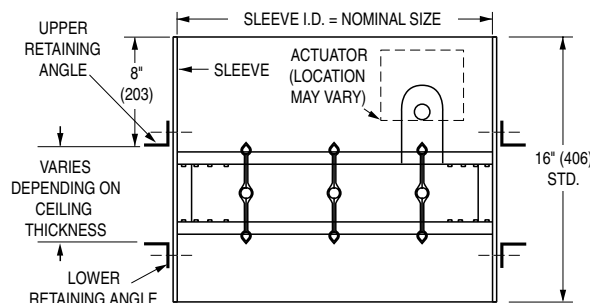

MODEL 1221C-3

COMBINATION FIRE/SMOKE DAMPERS



Model 1221C-3 Applications

Corridor Damper for use with Steel Grille/Diffuser:

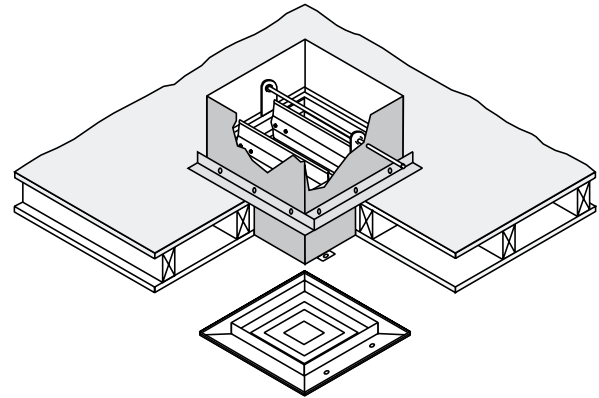
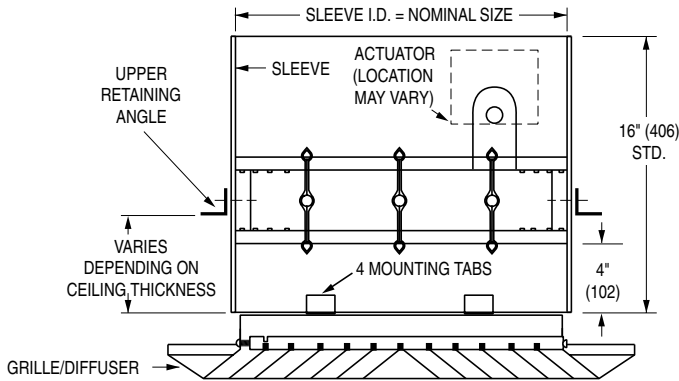

Corridor Damper for Ducted Installations:

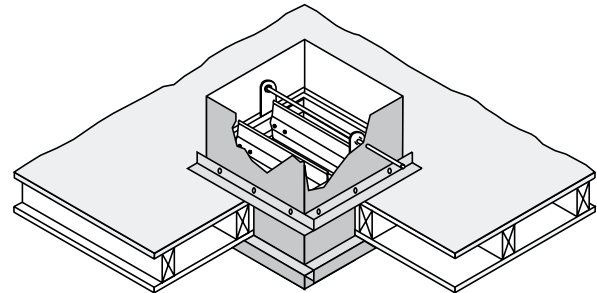
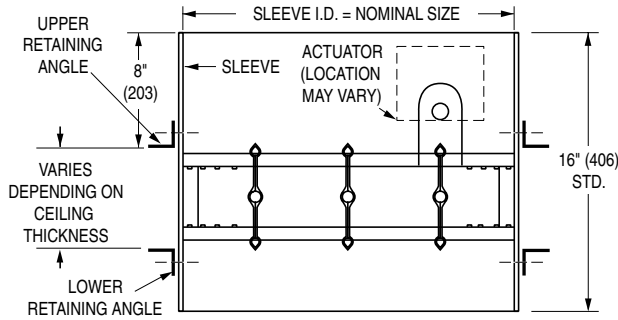

Combination Fire/Smoke Damper for Walls and Floors:

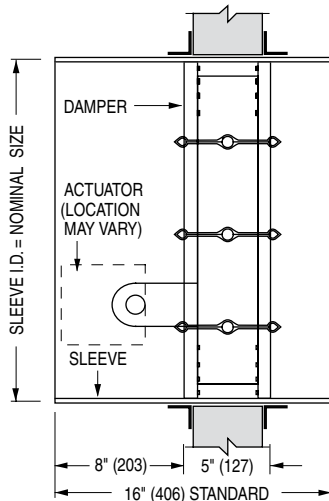

Wall Installation

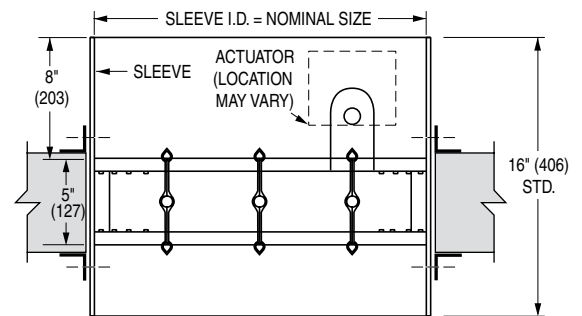

Floor Installation

PERFORMANCE DATA:

MODELS: 1221C-1 AND 1221C-2 - 1 HOUR LABEL

MODEL: 1221C-3 - 1 HOUR AND 1 1/2 HOUR LABEL

LEAKAGE CLASS:

The Model 1221C-1 and Model 1221C-2 Series Corridor Dampers have been designed and qualified under UL 555 and UL 555S in order to provide maximum system design flexibility. They are available with a Class I (currently the lowest available) leakage rating with all damper/actuator assemblies having been tested successfully at an elevated temperature of 250°F (121°C) or 350°F (177°C), dependent on actuator, under airflow of 2000 fpm at 4" w.g. (10 m/s @ 1 kPa).

The Model 1221C-3 Series Corridor Combination Fire/Smoke Damper has been designed and qualified under UL 555 and UL 555S in order to provide maximum system design flexibility. It is available with a Class I (currently the lowest available) leakage rating with all damper/actuator assemblies having been tested successfully at an elevated temperature of 250°F (121°C) or 350°F (177°C), dependent on actuator, under airflow of 2000 fpm at 4" w.g. (10 m/s @ 1 kPa).

Models 1221C-1 and 1221C-2 Maximum Performance Ratings	
UL 555 Corridor Damper Fire Rating	1 Hour
UL 555S Leakage Rating	Class I
Maximum Velocity	2000 fpm (10 m/s)
Maximum Pressure	4 in. w.g. (1 kPa)
Maximum Temperature	350°F (177°C)

Model 1221C-3 Maximum Performance Ratings	
UL 555 Corridor Damper Fire Rating	1 Hour
UL 555 Fire Damper Fire Rating	1 1/2 Hour
UL 555S Leakage Rating	Class I
Maximum Velocity	2000 fpm (10 m/s)
Maximum Pressure	4 in. w.g. (1 kPa)
Maximum Temperature	350°F (177°C)

PRESSURE DROP:

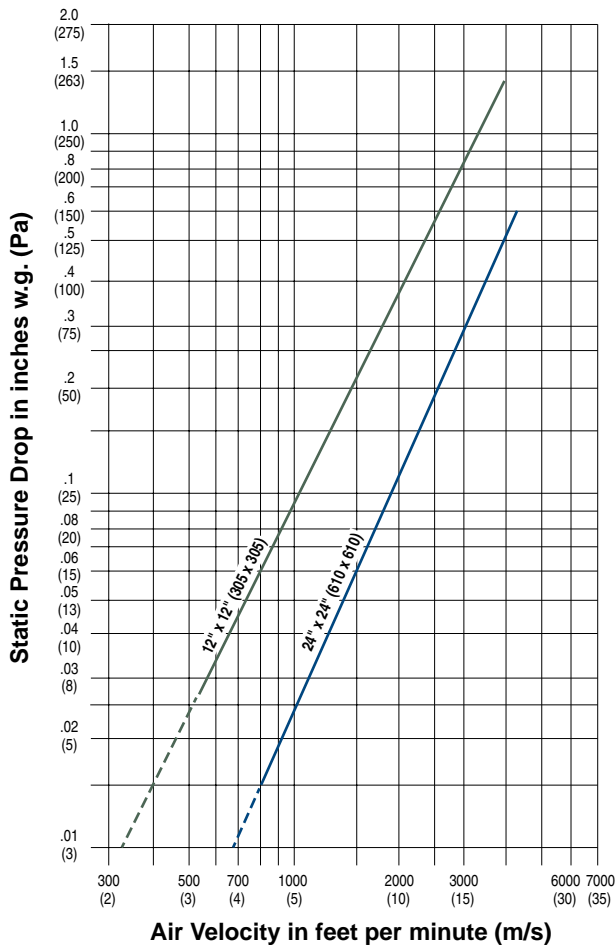

Pressure drop tested per AMCA Standard 500-D, Figure 5.3.
Data corrected to standard air density of 0.075 lbs/ft.³.



HOW TO ORDER

MODEL SERIES: 1221C

CORRIDOR DAMPERS

EXAMPLE: 1221C-1 - 24X24 - V - AUTO - 120 - I - 24 - 250 - ERL - 250 - BO - SL = 16 - 20G - EXT - RH - CL - FL12 - L8

- 1a. **Models**
Dynamic or Static Applications
 1221C-1 Corridor Damper, Airfoil Blade, 1 Hour Label
 1221C-2 Corridor Damper, Airfoil Blade, 1 Hour Label
 1221C-3 Corridor or Combination Fire/Smoke Damper, Airfoil Blade, 1/1 1/2 Hour Label
- 1b. **Sleeve/Enclosure Style (4th Digit)**
 1 = Type A Sleeve
2. **Duct Size**
 Width x Height or Diameter inches (mm's)
3. **Mounting**
 V Vertical (wall)
 H Horizontal (floor)
4. **Actuator Selected By**
 AUTO Least Cost (Auto-Select) (default)
 BEL Belimo
 HON Honeywell
 SIE Siemens
5. **Power Requirement**
 120 120 VAC (default)
 230 230 VAC
 24 24 VAC
 25 25 psi Pneumatic
6. **Leakage Rating**
 I Class I (default)
7. **Max. Velocity / Pressure Rating**
 24 2000 fpm @ 4" w.g. (default)
8. **Elevated Temperature**
 250 250°F (default)
 350 350°F
9. **Closure Device**
 ERL ERL Electric Resettable Link (default)
 PRL PRL Pneumatic Link
 DTO Dual Temperature Override Sensor (MLS-400)
10. **Closure Temperature**
ERL /PRL
 165 165°F
 212 212°F (PRL)
 250 250°F (ERL only) (default)
 280 280°F (PRL only)
 350 350°F (ERL only)
DTO Dual Temperature Override Sensor (MLS-400)
 HL 250/165°F
 HIL 350/165°F
11. **Bearings**
 BO Oilite Bronze (default)
 BS Stainless Steel
12. **Sleeve Length**
SL = Specify
 16" (406) standard (default)
 16" – 36" (406 – 914)
13. **Sleeve Gauge**
 20G 20 Ga. standard (default)
 18G 18 Ga.
 16G 16 Ga.
 14G 14 Ga.
 10G 10 Ga.
14. **Actuator Mounting**
 EXT External (default)
 INT Internal
15. **Actuator Location**
 RH Right hand (default)
 LH Left hand
 MH Multi-hand
16. **Actuator Fail Position**
 CL Close (default)
17. **Actuator Models**
Electric:
 HL1 MS4104F 120VAC
 HL2 MS8104F 24VAC
 HL3 MS4604F 230VAC
 HM1 MS4109F 120VAC
 HM2 MS8109F 24VAC
 HM3 MS4609F 230VAC
 HH1 MS4120F 120VAC
 HH2 MS8120F 24VAC
 HH3 MS4620F 230VAC
 GD2 GGD221 120VAC
 GD1 GGD121 24VAC
 GD3 GGD321 230VAC
 FT12 FSTF120 120VAC
 FT23 FSTF230 230VAC
 FT24 FSTF24 24VAC
 FL12 FSLF120 120VAC
 FL23 FSLF230 230VAC
 FL24 FSLF24 24VAC
 F12 FSNF120 120VAC
 F23 FSNF230 230VAC
 F24 FSNF24 24VAC
 FA12 FSAF120A 120VAC
 FA23 FSAF230A 230VAC
 FA24 FSAF24A 24VAC
Pneumatic:
 296 331-2961
 306 331-3060
18. **Damper Location**
 L8 8" (203) from sleeve end (default)
- OPTIONS & ACCESSORIES:**
19. **Position Indicator**
 — None (default)
 300 MLS-300 (4-wire) (Included with Dual Temperature Override Sensor [DTO])
20. **EP Switch**
 — None (default)
 EP1 120 VAC
 EP2 24 VAC
21. **Upper Angles**
 UNM Upper Angles, Not Mounted (default) Models 1221C-2 and 1221C-3 only
 UFM Upper Angles, Factory Mounted, Specify ceiling thickness Ceiling _____ inches/mm
22. **Lower Angles**
 — None (default)
 LNM Lower Angles, Not Mounted Models 1221C-2 and 1221C-3 only
23. **Angle Location**
 — None (default)
 LO Angle Location
24. **Transition Collar**
 SRT Top Transition _____ dia. specify Models 1221C-1 and 1221C-2 only
 SRB Bottom Transition, Model 1221C-2 only _____ dia. specify
 SR2 Top and Bottom Transition, Model 1221C-2 only _____ dia. specify
25. **Damper Test Switch**
 — None (default)
 DTS Damper Test Switch
- Notes:**
1. Not all variants and options are available on all models. Refer to individual model for selection availability.
2. ERL is standard on all dampers with electric actuators. PRL is standard on all dampers with pneumatic actuators.
 An ERL or DTO (MLS-400) may be ordered on dampers with pneumatic actuators, but in addition, an EP switch (factory mounted) is required.
3. EP (electric-pneumatic) switch accessory is applicable only to pneumatic actuators and is optional (shipped loose) when PRL closure device is selected.
4. One DTO (MLS-400) or MLS-300 required per damper assembly. DTO (MLS-400) includes MLS-300 position indicator.
5. Maximum Closure Temperature allowed is equal to Damper Elevated Temperature.

HOW TO SPECIFY

MODELS: 1221C-1 AND 1221C-2 - 1 HOUR LABEL CORRIDOR DAMPERS

SUGGESTED SPECIFICATION:

Provide and install, as shown on plans and/or schedules, Corridor Dampers as manufactured by Nailor Industries, Inc., which meet or exceed the following criteria:

Dampers shall meet the requirements of NFPA 90A and 92. Dampers shall be classified by Underwriters Laboratories and labeled as a 1 hour fire resistance rated Corridor Damper and as a Class I Leakage Rated Smoke Damper under UL 555S at an elevated temperature of (**specifier select temperature**) 250°F (121°C) or 350°F (177°C). Dampers shall be tested under UL 555 and UL 555S by UL to a minimum velocity/pressure rating of 2000 fpm @ 4" w.g. (10 m/s @ 1 kPa).

Frame shall be constructed of 16 ga. (1.6) galvanized steel hat channel with mitered corners reinforced with die-formed corner gussets for strength. Blades shall be 14 ga. (2.0) equivalent galvanized steel formed double-skin airfoil design on 5 1/2" (140) centers. Dampers shall be of opposed blade configuration with an interlocking blade design that provides complete flame and smoke seal under fire conditions at an elevated temperature of 2000°F (1093°C) when in the closed position. Dampers requiring blade seals to maintain leakage class when under elevated temperature conditions are not acceptable. Blades axles shall be 1/2" (13) dia. plated steel, double bolted at each end of blade to ensure positive locking connection. Hex, square friction-fit or press-fit axles are not acceptable. Bearings shall be self-lubricating oilite bronze type. Blade linkage shall be zero-maintenance, concealed in frame; out of airstream. Jamb seals shall be compression type stainless steel. Dampers shall be supplied with factory installed sleeves, length dependent on wall thickness, minimum 16" (406). Wall thickness shall be field verified by contractor. Factory sleeves shall be caulked to UL requirements and shall be complete with factory supplied upper retaining angles of minimum 1 1/2" x 1 1/2" x 16 ga. (38 x 38 x 1.6) galvanized steel.

Appropriate (**specifier select**) externally or internally mounted (**specifier select type**) electrical or pneumatic actuators shall be installed by the damper manufacturer in the factory. Actuators shall incorporate an OEM internal spring return mechanism; external after-market spring mechanisms are not acceptable. Each damper shall be equipped with a UL classified heat responsive device that will cause the damper to close in a controlled manner and lock in a closed position by means of an over center/knee lock linkage when the duct temperature reaches the maximum degradation temperature of the damper/actuator assembly, as required by UL 555S. Closure devices that cause instantaneous closure are not acceptable. Damper and actuator assembly shall be factory cycled a minimum of 3 times to ensure correct operation.

Damper manufacturer shall submit pressure drop data to be based on tests in accordance with AMCA Standard 500-D. For applications where ductwork terminates at the ceiling, standard of acceptance shall be Nailor Industries Model 1221C-1. For applications where continues down past the ceiling, standard of acceptance shall be Nailor Industries Model 1221C-2.

MODEL: 1221C-3 - 1 HOUR LABEL OR 1 1/2 HOUR LABEL CORRIDOR DAMPERS

SUGGESTED SPECIFICATION:

Provide and install, as shown on plans and/or schedules, Corridor Dampers as manufactured by Nailor Industries, Inc., which meet or exceed the following criteria:

Dampers shall meet the requirements of NFPA 90A and 92. Dampers shall be classified by Underwriters Laboratories and labeled as a (**specifier select rating**) 1 hour fire resistance rated Corridor Damper or 1 1/2 hour Fire Damper under UL 555, and as a Class I Leakage Rated Smoke Damper under UL 555S at an elevated temperature of (**specifier select temperature**) 250°F (121°C) or 350°F (177°C). Dampers shall be tested under UL 555 and UL 555S by UL to a minimum velocity/pressure rating of 2000 fpm @ 4" w.g. (10 m/s @ 1 kPa).

Frame shall be constructed of 16 ga. (1.6) galvanized steel hat channel with mitered corners reinforced with die-formed corner gussets for strength. Blades shall be 14 ga. (2.0) equivalent galvanized steel formed double-skin airfoil design on 5 1/2" (140) centers. Dampers shall be of opposed blade configuration with an interlocking blade design that provides complete flame and smoke seal under fire conditions at an elevated temperature of 2000°F (1093°C) when in the closed position. Dampers requiring blade seals to maintain leakage class when under elevated temperature conditions are not acceptable. Blades axles shall be 1/2" (13) dia. plated steel, double bolted at each end of blade to ensure positive locking connection. Hex, square friction-fit or press-fit axles are not acceptable. Bearings shall be self-lubricating oilite bronze type. Blade linkage shall be zero-maintenance, concealed in frame, out of airstream. Jamb seals shall be compression type stainless steel. Dampers shall be supplied with factory installed sleeves of minimum 16" (406) length, dependent on (**specifier select application**) ceiling or wall thickness, and shall be field verified by contractor. Factory sleeves shall be caulked to UL requirements and shall be complete with factory supplied upper retaining angles of minimum 1 1/2" x 1 1/2" x 16 ga. (38 x 38 x 1.6) galvanized steel.

Appropriate (**specifier select**) externally or internally mounted (**specifier select type**) electrical or pneumatic actuators shall be installed by the damper manufacturer in the factory. Actuators shall incorporate an OEM internal spring return mechanism; external after-market spring mechanisms are not acceptable. Each damper shall be equipped with a UL classified heat responsive device that will cause the damper to close in a controlled manner and lock in a closed position by means of an over center/knee lock linkage when the duct temperature reaches the maximum degradation temperature of the damper/actuator assembly, as required by UL 555S. Closure devices that cause instantaneous closure are not acceptable. Damper and actuator assembly shall be factory cycled a minimum of 3 times to ensure correct operation.

Damper manufacturer shall submit pressure drop data to be based on tests in accordance with AMCA Standard 500-D. Standard of acceptance shall be Nailor Industries Model 1221C-3.

Options and Accessories

Nailor combination fire and smoke dampers are tested by and listed with Underwriters Laboratories Inc. and are manufactured within UL procedural requirements.

CLOSURE DEVICES:

OPTION CODE **ERL** ELECTRIC RESETTABLE LINK

The ERL Electric Resettable Link (heat sensor) is the standard closure mechanism on all Nailor combination fire/smoke dampers ordered with an electric actuator. The ERL is a thermally responsive bimetal disc/thermostat that opens and closes electrical contacts at a specific calibrated temperature. The ERL is a UL Classified Heat Responsive Device.

The standard ERL on Nailor combination fire/smoke dampers has a fixed temperature setting of 250°F (121°C) which is the UL listed elevated/degradation temperature of the damper/actuator assembly. A 350°F (177°C) elevated temperature classification and ERL is available as an option. A 165°F and 212°F (74°C and 100°C) ERL are also available. Local codes have specified 165°F (74°C) widely in the past.

The ERL performs the same function as the fusible link, that is to sense an abnormally high temperature, as caused by a fire and allow the damper to close in order to prevent the spread of fire and smoke. The sensor interrupts power to the actuator and the actuator's spring return mechanism causes the damper to close and lock.

In smoke control mode, when a signal is detected via a normally closed smoke detector connection, the damper will close and remain closed until the smoke signal ceases. The system will then reset when power is re-applied and the damper will open. The damper may be closed at any time by placing a control switch (optional and by others) in the closed position.

The ERL sensor is of the manual reset type and can be reset after the temperature has cooled down below the sensor set point. This feature is a tremendous advantage where periodic system testing involves application of heat to the sensor to verify correct damper operation. Exposure to actual fire conditions may render these devices unusable. In this case, it is recommended that a careful inspection of the damper, actuator and ERL be performed.

The ERL in combination with all Nailor qualified electric (or pneumatic) actuators provides controlled closure and eliminates the instantaneous damper closure associated with traditional fusible links that can cause damage to the ductwork.

The ERL requires factory installation and wiring together with the associated actuator to meet UL requirements. Note that dampers provided with pneumatic actuators utilize the PRL (see below) as standard (max. 280°F [138°C]) but can be provided with the ERL. An EP switch is required in this case.

OPTION CODE **PRL** PNEUMATIC REPLACEABLE LINK

The Nailor PRL Pneumatic Replaceable Link is a UL Classified heat responsive device used in conjunction with Nailor combination fire/smoke dampers.

A 212°F (100°C) PRL is supplied as standard on all combination fire/smoke dampers ordered with a pneumatic actuator. A 165°F and 280°F (74°C and 138°C) PRL are also available. An alternative to the PRL would be the Nailor

ERL (Electric Resettable Link) with an EP (Electric/Pneumatic) switch.

The PRL is a factory mounted pneumatic release valve/replaceable fusible link assembly. The PRL's function is to sense an abnormally high temperature, as caused by a fire, and allow the damper to close in order to prevent the spread of fire and smoke.

Fire Control Mode: The PRL activates when a fire temperature in excess of 165°F, 212°F or 280°F (74°C, 100°C or 138°C) is detected. When the fusible link melts, air from the pneumatic actuator(s) is exhausted and the actuator spring return mechanism causes the damper to close and lock.

Smoke Control Mode: When a signal is detected via a normally closed smoke detector connection, during system testing or if power failure occurs, the damper will close and remain closed. When the smoke signal ceases (smoke detector reset), the test is completed or power is restored, the damper will automatically reset to the open position.

An EP (electric/pneumatic) switch, by others, must be present in the system.

All pneumatic actuators are factory mounted with a fail close (Normally Closed) damper connection.

Notes:

1. The PRL must be installed at the factory and cannot be added in the field, in accordance with UL requirements.
2. A single PRL may be use to control up to a maximum of four pneumatic actuators.
3. Pneumatic actuators are to be field piped per local codes.

CLOSURE DEVICES:

OPTION CODE DTO (ML4)
DUAL TEMPERATURE OVERRIDE
SENSOR
REOPENABLE CONTROL PACKAGE

- **REOPENABLE HEAT SENSOR W/POSITION INDICATOR SWITCH PACK**
- **FOR USE IN ENGINEERED SMOKE CONTROL SYSTEMS**

The DTO Dual Temperature Override Sensor is a UL Classified reopenable control/status indicator package that is a factory installed option on all Nailor Combination Fire/Smoke dampers.

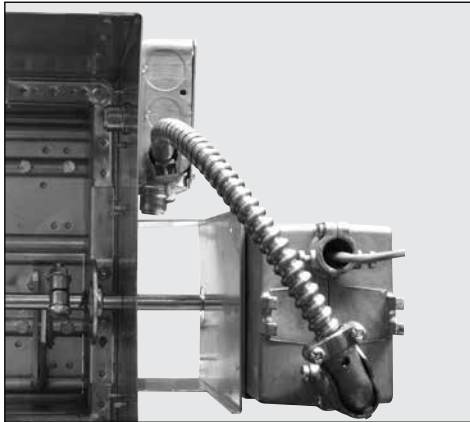

HOW THE DTO DUAL TEMPERATURE OVERRIDE SENSOR WORKS:

UL 555 permits Combination Fire/Smoke dampers to be equipped with both a primary (low limit) and secondary (high limit) heat responsive closure device. This allows the appropriate authority (from a remote fire fighters' smoke control station) to bypass/override the primary sensor, usually 165°F (74°C), after fire induced closure or smoke detector signal and reopen the damper as may be required for smoke control functions. The damper can be operated in this 'override mode' until the elevated temperature limit of 250°F (121°C) or 350°F (177°C) is sensed at the damper. The secondary heat responsive device, a 250°F (121°C) or 350°F (177°C) manually resettable heat sensor, then returns it to the fire protection mode, permanently reclosing the damper and rendering it inoperable, as required by UL 555 and NFPA 90A.

The built-in damper position indicator switch provides positive indication of either fully open or closed damper status.

A WORD ABOUT "REOPENABLE" CONTROLS....

The dual temperature rated reopenable closure option was originally developed during the 1980's to comply with NFPA 90A requirements that mandated the primary (low limit) closure temperature to be a maximum of 286°F (141°C). The dual temperature closure option permits the damper to close when the primary closure temperature rating of 286°F (141°C) or less (usually 165°F [74°C]) is reached, then be reopened to utilize the duct for smoke removal until the secondary (high limit) closure device temperature rating, usually 350°F (177°C) is reached.

The 1996 edition of NFPA 90A revised the maximum primary closure temperature to 350°F (177°C) or the elevated temperature rating of the damper (250°F [121°C] or 350°F [177°C]). This revision virtually eliminates the need for a "reopenable" type control system as the damper can now remain operational during the HVAC system's designed smoke control mode until 350°F (177°C) is reached. However, there is still a misconception that this dual temperature rating option is necessary to meet the requirements of both NFPA and UL, as well as local building codes, in order for the damper to be utilized for smoke removal until its elevated temperature rating is reached. Although it does provide a method of complying with some building codes that require fire dampers to close at 212°F (121°C) or less, while still providing the potential to reopen the damper for smoke removal reasons, in most cases the disadvantages render it obsolete. The cost of the additional wiring and intricate controls required, when compared to the cost of a single 250°F (121°C) or 350°F (177°C) closure device, can rarely be justified. Also the complexity of the design may in fact hinder its proper use if personnel are not properly trained, at further cost, to operate it during an emergency.

Therefore, as the dual temperature rated closure option and its associated higher costs are no longer required to comply with NFPA 90A, Nailor recommends using a single 250°F (121°C) or 350°F (177°C) closure device in engineered smoke control systems as the logical selection. If the system is designed to accommodate damper open/closed status indication, Nailor's MLS-300 Position Indicator option provides a simple, functional means to a complete smoke control package.

CLOSURE DEVICES:

ADVANTAGES OF NAILOR'S EXTERNAL LOW LIMIT HEAT SENSOR

Nailor's **DTO Dual Temperature Override Sensor** features a low-limit heat sensor that is mounted outside the duct adjacent to the actuator rather than inside the duct. As most fires originate outside the duct, which is commonly insulated, an internally mounted heat sensor would not trip as early. And as most actuators and electrical wiring are located on the external surfaces of the sleeve, they could be subjected to damaging temperatures long before an internally mounted heat sensor trips. Nailor's **DTO Dual Temperature Override Sensor** ensures that the damper will close within the temperature limits of the actuator and before any damage to external components can occur.

The **DTO Dual Temperature Override Sensor** may be used with either a UL Listed Electric Actuator or Pneumatic Actuator. Connections to the junction box are the same.

COMBINATION FIRE/SMOKE DAMPERS

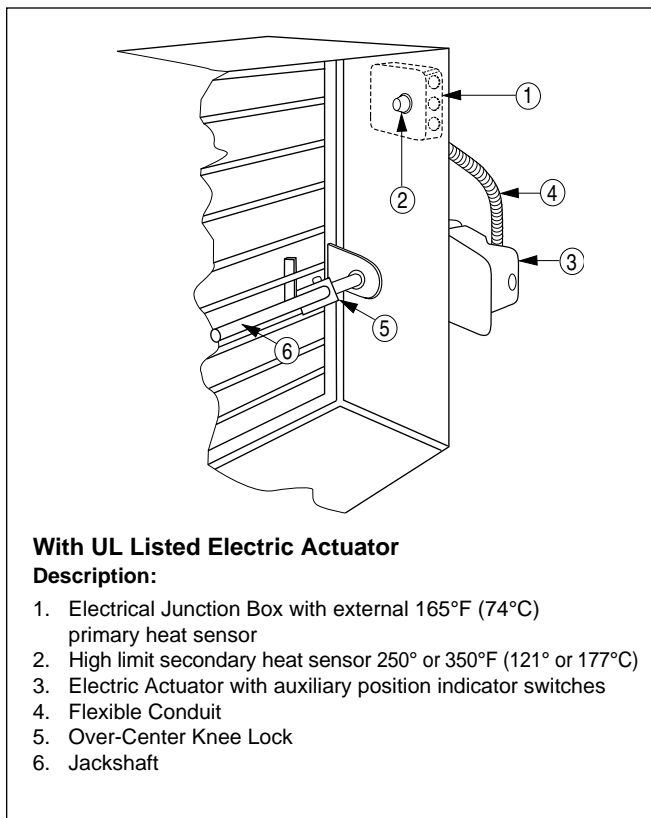

WITH UL LISTED ELECTRIC ACTUATOR

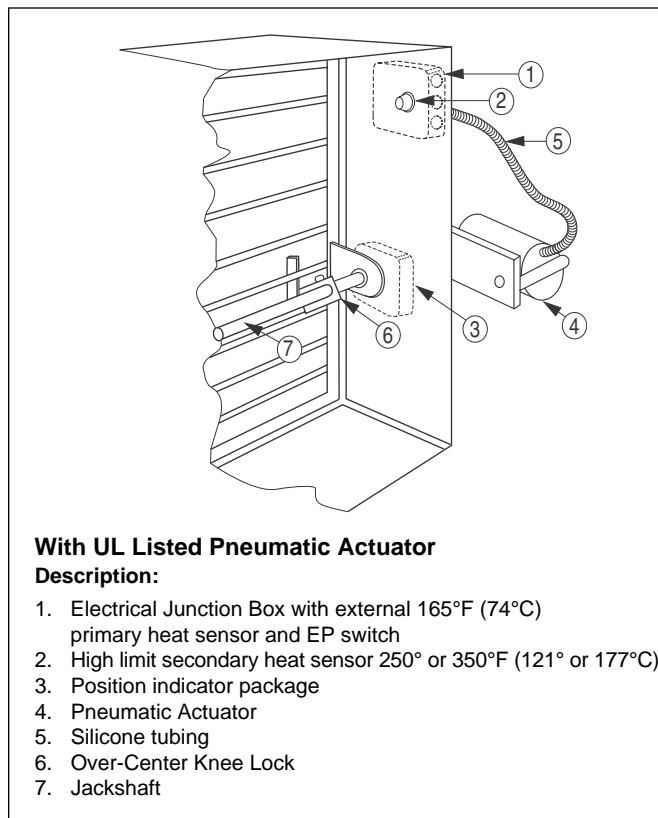

WITH UL LISTED PNEUMATIC ACTUATOR

CLOSURE TEMPERATURE:

OPTION CODES
165 212 250 280 350
 CLOSURE TEMPERATURE

ERL/PRL's for Nailor's Combination Fire/Smoke dampers are available with a choice of several closure temperature ratings. Nailor combination fire/smoke dampers are equipped as standard with a 250°F (121°C) ERL or a 212°F (100°C) PRL. Available 165°F (74°C), 212°F (100°C) or 350°F (177°C) ERL's and 165°F (74°C) or 280°F (138°C) PRL's can be installed on damper at time of manufacturing.

The National Fire Protection Association Standard 90A requires that combination fire/smoke dampers that are part of an engineered smoke-control system shall have a heat responsive device with a temperature rating approximately 50°F (28°C) above the maximum smoke control system designed operating temperature, but not to exceed the UL 555S elevated temperature rating of the damper assembly or a maximum of 350°F (177°C).

OPTION CODE
HL250/165°F OR HL350/165°F
 HIGH/LOW CLOSURE TEMPS.
 FOR DTO DUAL TEMPERATURE
 OVERRIDE SENSOR

Nailors' DTO Dual Temperature Override Sensor reopenable control package utilizes two separate heat responsive devices to automatically close the damper: a 'low limit' primary device rated at 165°F (74°C) or 212°F (100°C) that closes the damper upon sensing heat at selected temperature, but can be overridden from the fire fighters smoke control station to reopen damper for smoke control purposes; a 'high limit' secondary device of either 250°F (121°C) or 350°F (177°C) temperature rating that permanently re-closes the damper upon sensing heat at selected temperature, rendering it inoperable, as required by UL 555 and NFPA 90A. The high limit temperature rating cannot be higher than the elevated temperature rating of the damper assembly as determined by UL 555S Standard for Smoke Dampers. As NFPA 90A requires that the closure device shall have a temperature rating approximately 50°F (28°C) above the maximum smoke control system designed operating temperature, the low limit (primary closure device) temperature rating, either 165°F (74°C) or 212°F (100°C) should be selected based on this criteria. When selecting the high limit secondary device temperature rating (either 250°F [121°C] or 350°F [177°C]), Nailor recommends 350°F [177°C], as this will provide additional time for the damper to be utilized in smoke control mode until it is closed permanently. Remember that the high limit temperature selected can not be higher than the elevated temperature rating of the damper assembly as determined by UL 555S.

UL 555 Closure Temperature Requirements
 As of July 1, 2002, UL 555 Safety Standard for Fire Dampers, Sixth Edition (June 1999) requires that combination fire and smoke dampers have a heat responsive device of minimum 160°F (71°C), maximum 350°F (177°C) temperature rating but it cannot be greater than the UL 555S elevated temperature rating of the damper assembly. For reopenable combination fire and smoke dampers the temperature rating of the primary heat responsive device must be minimum 160°F (71°C), maximum 212°F (100°C). The temperature rating of the secondary heat responsive device must be greater than that of the primary device, but cannot exceed 350°F (177°C) or the UL 555S elevated temperature rating of the damper assembly.

POSITION INDICATORS:

OPTION CODE 300
 MLS-300 POSITION INDICATOR
 SWITCH PACK

The **MLS-300 Series Position Indicator Switch Pack** is generally utilized to indicate open and closed position of the damper blades. It incorporates two SPDT switches that may be used to operate signal lamps or to provide a start/stop circuit for remote fans or to signal alarms.

MLS-300's are used in active smoke control management systems to positively indicate the status of all combination fire/smoke and smoke dampers in the building. The **MLS-300** is available only as a factory installed option on combination fire/smoke and smoke dampers.

Features:

- Operates as a function of the damper blade position.
- Provides remote indication of damper blade position.
- Provides the ability to remotely control ON/OFF fan stations.
- Provides the ability to remotely signal alarms.

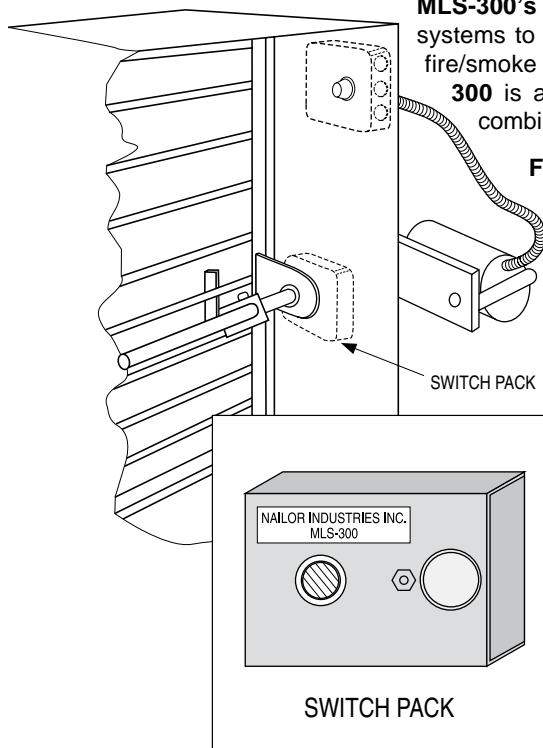

Built-in Actuator Switch Packs

Many of the newer application specific actuators designed for use on fire/smoke dampers feature “add-on” component position indicator switches manufactured and UL tested by the actuator manufacturer. Honeywell MS4109F/MS8109F actuators are examples.

Some actuator models have variants with position indicator switches built right in to the actuator. Honeywell MS4120F/MS8120F and Belimo FSNF24S/FSNF120S actuators are examples.

When ordered with the MLS-300 Position Indicator Switch Pack, Nailor combination fire/smoke and smoke dampers that utilize these actuators will usually be supplied with the actuator mounted switch pack, factory installed as required by UL.



POSITION INDICATORS:

MLS-300N (NAILOR) SWITCH DETAILS

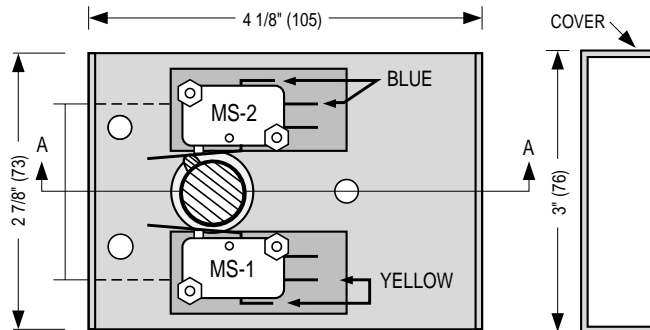

EXTERNAL RIGHT HAND MOUNTING: FRONT VIEW (LESS COVER)

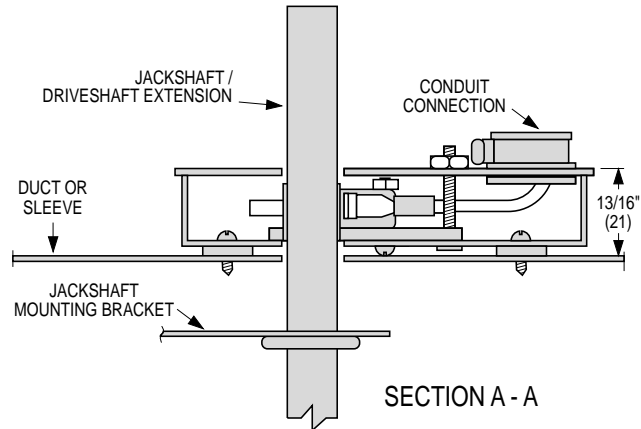

TYPICAL JACKSHAFT MOUNTING

Position Indicator Microswitch Data:

Switch Type: Single Pole double throw (2)
 15 Amps, 1/3 HP, 125, 250 Vac or 24 Vdc.
 1/2 Amp, 125 Vdc. 1/4 Amp, 250 Vdc.

Standard Mounting:

MS1 is damper open signal.
MS2 is damper closed signal.

Non-Standard Mounting:

Important: Installer must double check continuity of MS1 and MS2 before wiring to determine which switch signals the damper's open or closed position.

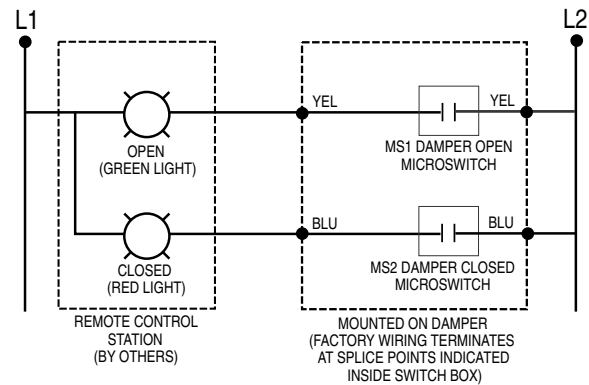

MLS-300 TYPICAL WIRING DETAILS



ELECTRO-PNEUMATIC SWITCHES:

OPTION CODES EP1 AND EP2

EP1 120 VAC E/P SWITCH
EP2 24 VAC E/P SWITCH



Nailor Options **EP1** and **EP2** electro-pneumatic switches are electrically operated, two-position 3-way air valves. They are used to interlock an electrical smoke or fire alarm system with a pneumatic damper actuator. The **EP1 (120 VAC)** and **EP2 (24 VAC)** valves are utilized to alternately apply pressure to, and exhaust pressure from a pneumatic damper actuator by an electrical input that energizes or de-energizes the solenoid of the switch. Barb type pneumatic piping connections are sized

for 1/4" (6) O.D. Polyethylene tubing. Units are UL and CSA approved and may be mounted in any position.

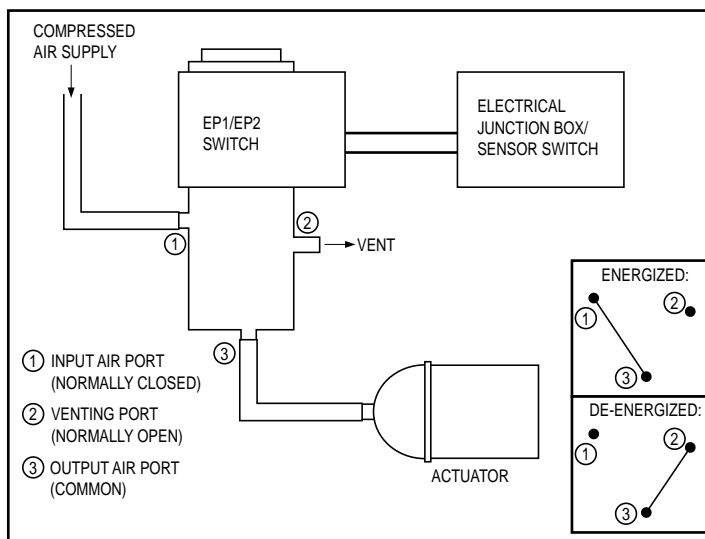

OPERATION:

Input air is connected to port 1 (normally closed) and the output to the actuator is connected to port 3 (common). When the solenoid is energized port 1 connects to port 3 allowing the actuator to be controlled by input air, usually holding the damper in open position. When the solenoid is de-energized, port 2 (normally open) is connected to port 3, exhausting the air from the actuator allowing it to return to its normal fail position (fail open or fail closed).

RETAINING ANGLES:

OPTION CODES
QS2 TWO SIDES (PAIR)
QS1 ONE SIDE
 'QUICK-SET' RETAINING ANGLES

FOR USE WITH ALL COMBINATION FIRE/SMOKE DAMPERS (EXCEPT MODEL 1290FS)

- Maximum size: 90" x 48" (2286 x 1219) or 48" x 90" (1219 x 2286).

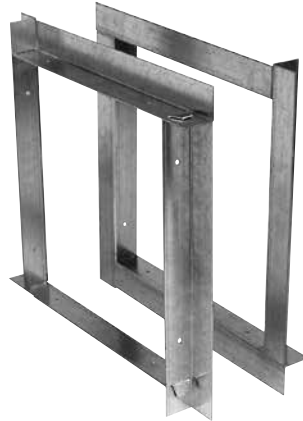

BENEFITS:

- Factory fabricated by the manufacturer to suit the individual fire damper.
- Dampers can ship directly to the job site complete with all necessary installation sheet metal hardware (saves on double handling at contractor's shop).
- Reduced cost when compared to conventional retaining angles.
- Only two sets of angles to handle per damper (rather than eight).
- Angles ship with individual damper - no sorting or matching.
- Pre-drilled holes on 8" (203) centers to ensure correct angle/sleeve attachment.
- Help ensure a correct installation as per U.L. approved installation instructions.

The majority of installing contractors view fire damper installation as a costly time consuming and troublesome procedure. Eight conventional angles must be custom fabricated for each damper either in a sheet metal shop or at the job site and sized to suit each individual damper. Invariably, they are mislaid or lost and must be matched to each factory supplied damper. The Nailor "Quick-Set" solution solves the majority of problems. They are pre-formed to fit each damper and shipped with the individual damper units for ultimate convenience.

Nailor "Quick-Set" retaining angles are an accessory option for all dampers ordered with factory sleeves.

QS2: Two sides (pair). For standard installations where angles are installed on both sides of the fire partition.

QS1: One side (single set). For use in a single side retaining angle installations and with grille mount and "out of wall" damper models. "Quick-Set" angles are supplied with correctly spaced pre-drilled screw-holes to ensure a quick, easy and accurate installation for all Nailor fire dampers - no measuring required.

"Quick-Set" retaining angles when specified and supplied with Nailor integral sleeve fire dampers provide the "complete" installation package. Simple, fast, convenient.

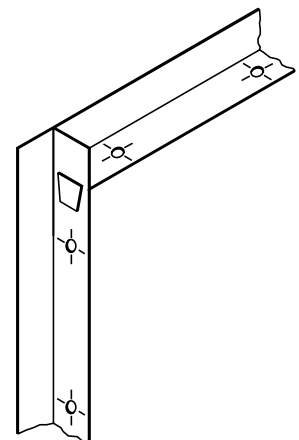
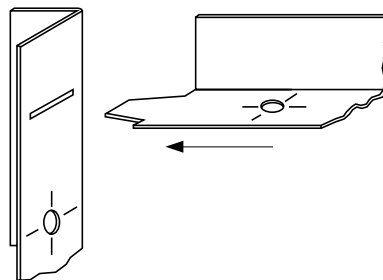
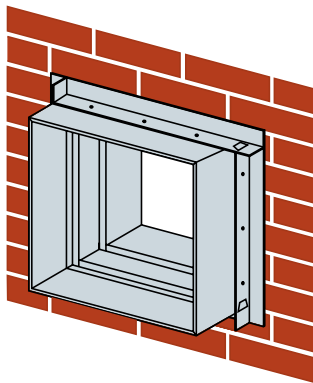

Style 1: 1 1/2" x 1 1/2" x 20 ga. (38 x 38 x 1.0) Four sides are connected together with rivets in three corners. Standard for the majority of applications with the following limitations:

- 1 1/2 hour label fire dampers.
- Maximum Size: 36" x 36" (914 x 914).
- Two sided installation only.

Style 2: 1 1/2" x 1 1/2" x 16 ga. (38 x 38 x 1.6) Slot and tab design. The retaining angle assembly for each side has four angles, each with a tab end and a slot end (Detail A). The tabs are to be inserted into the slots and knocked down either before or after fastening to the sleeve (Detail B).

- 1 1/2 or 3 hour label fire dampers.
- Maximum Size: 90" x 48" (2286 x 1219) or 48" x 90" (1219 x 2286).
- Single side (1 1/2 hour only. Refer to Single Side Retaining Angles Supplementary Installation Instructions for size limitations) or two sided installation.



SLEEVES OR SIDE MOUNTING PLATE:

TYPE A SLEEVES
MODELS 1221 and 1271

Nailor strongly recommends that all combination fire/smoke dampers including Type A models, are specified and ordered complete with a factory installed full sleeve (Type B and C models are manufactured as standard with transition casing that acts as a sleeve). A factory installed sleeve allows the units to ship directly to jobsite ready for installation, saving time, money and costly field fabrication and mounting, as well as helping to ensure proper installation and caulking to UL requirements. As all combination fire/smoke dampers are required to be installed in a sleeve, and all actuators must be factory mounted, a factory supplied sleeve provides the easiest and most cost effective method to accomplish this as well as ensuring that the damper/actuator assembly functions properly. Standard sleeve is 16" (406) long. See Models 1221 and 1271 for further damper/sleeve details.

The following indicates model numbers to order for combination fire/smoke dampers with factory fitted Type A sleeves:

STANDARD MODEL #	WITH TYPE A SLEEVE
1220 →	MODEL 1221
1270 →	MODEL 1271

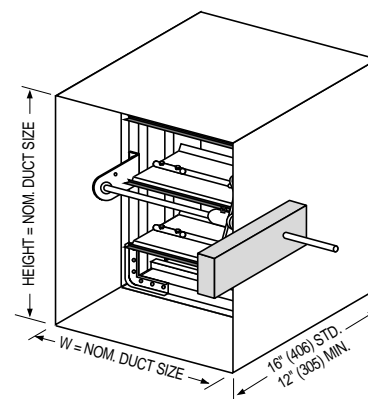

OPTION CODE **SMP**
SIDE MOUNTING PLATE

Although not recommended, Nailors **SMP** Side Mounting Plate provides a method of factory installing an externally mounted actuator onto Model Series 1220 and 1270 combination fire/smoke dampers. UL 555 and UL 555S safety standards latest editions require that actuators shall be factory mounted. This is to help ensure that the damper/actuator assembly functions properly and eliminates possible jobsite installation errors. As with all combination fire/smoke dampers, an appropriate full steel sleeve must be field fabricated for installation of damper in wall or floor.

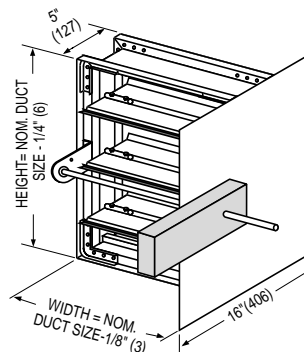

SIDE MOUNTING PLATE FOR COMBINATION FIRE/SMOKE DAMPERS

COMBINATION FIRE/SMOKE DAMPERS



FLANGED SLEEVE

OPTION CODES
 TDF FLANGE
TDF2 BOTH ENDS
TDF1 ONE END



TDF (by Engle) and **TDC** (by Lockformer) proprietary flange systems are approved as breakaway connections for connecting a combination fire/smoke damper Type A sleeve (22 or 20 gauge) to ductwork. They may be used in place of the approved slip joints shown in standard installation instructions.

For Option **TDF1** the sleeve is factory flanged on one end only.

For Option **TDF2** the sleeve is factory flanged on both ends.

Note that the maximum wall/floor opening size permitted by UL, relative to the damper size, may not physically allow the flange to fit through the opening. Consultation and co-ordination with the wall/floor contractor is recommended. **TDF1**, flange on one end only, will permit the non-flanged end of the sleeve to fit through the opening. Specify which end to be flanged in relation to the jackshaft.

Maximum TDF1/TDF2 Sleeve Size Allowed:
For Curtain Type Fire Damper: 60" wide x 60" high (1524 x 1524).
For Multi-Blade Type Fire Damper: 36" wide x 48" high (914 x 1219).



DAMPER TEST SWITCH

OPTION CODE DTS
PUSH BUTTON TEST SWITCH

The DTS (Damper Test Switch) is an optional “momentary” push button test switch available on all Nailor smoke and combination fire/smoke dampers. The DTS provides the ability to “cycle test” the damper by pushing and holding down the button until the damper has cycled and closure has been visually verified, either by inspecting the damper through the access door or by confirmation at a remote control panel when equipped with the optional MLS-300 position indicator.

The DTS is mounted right on the damper and enables a single maintenance person to test and cycle the damper, eliminating the need for help from another person in the control room.

When a combination fire/smoke damper is ordered, the DTS is combined with the ERL (Electric Resettable Link).

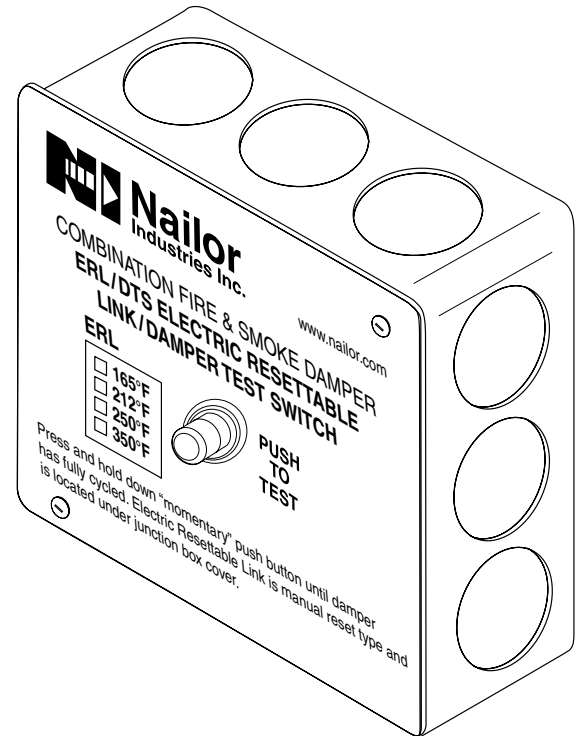

DTS/ERL Damper Test Switch w/Electric Resettable Link

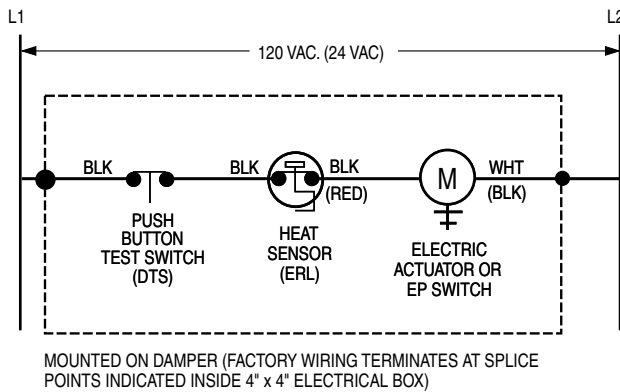

Figure 1. DTS/ERL Damper Test Switch with Electric Resettable Link

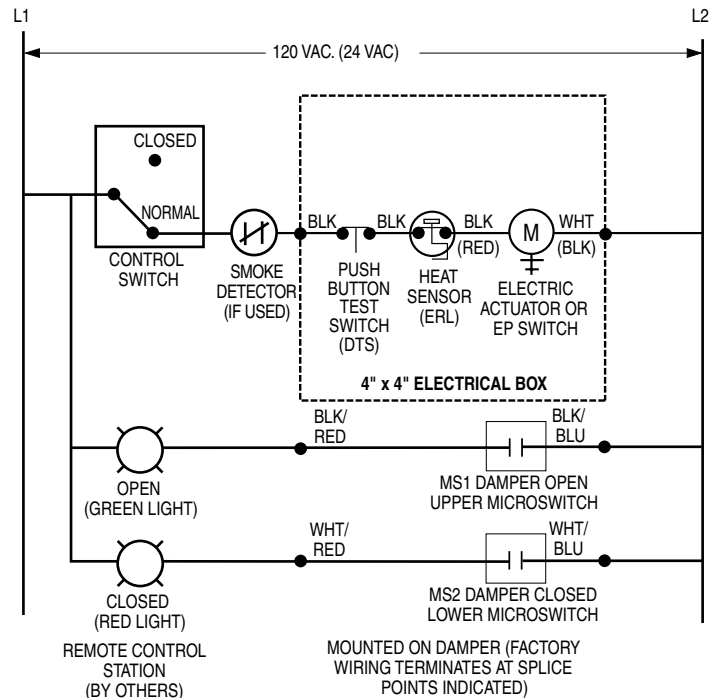

Figure 2. DTS/ERL with MLS-300 (Honeywell) Position Indicator Package (rotary cam type)

COMBINATION FIRE/SMOKE DAMPERS

DUCT SMOKE DETECTORS:

OPTION CODE DSDN
 DSD-NF NO-FLOW
 DUCT SMOKE DETECTOR

APPLICATION:

Nailor Model DSD-NF duct smoke detector (no-flow) can be utilized with Nailor UL555S Classified combination fire/smoke dampers to detect the presence of smoke within HVAC ductwork, whether or not there is airflow, and close the damper to prevent the smoke from spreading. As most fatalities resulting from fires can be attributed to the effects of toxic smoke, detecting and controlling the smoke from spreading within the HVAC system is vital to preventing injury as well as limiting property damage, including damage to the HVAC system itself. Refer to NFPA Standards 72, 90A and 92 to determine when and where duct smoke detectors are required.

The DSD-NF detector features a low-profile design for optimum pressure drop and will operate with airflow in either direction. It can be factory installed to top of sleeve (side mounting optional) on Nailor Model Series 1220 and 1270 combination fire/smoke dampers.

OPERATION:

Upon detection of smoke, the smoke detector causes the damper to close by cutting off power to the actuator. The actuator return spring forces the damper closed. The detector can be reset only by a momentary power interruption. The standard model DSD-NF detector and smoke damper combination is designed simply to close the damper upon detection of smoke. For applications requiring the detector to be wired into a fire fighters' smoke-control station (FSCS), contact Nailor.

DSD-NF STANDARD SPECIFICATION:

Model: System Sensor 2151 Low-Profile.

Sensor Type: Photoelectric.

Dimensions: 6.1" (155) dia. flanged base.

Weight: 3.6 oz. (104 g).

Airflow Velocity Range: 0 to 3000 fpm (0 to 15.24 m/s).

Operating Temperature Range: 32°F to 120°F (0°C to 49°C).

Operating Humidity Range: 10% to 93% Relative Humidity Non-Condensing.

Sensitivity: 3% ± .7%/ft

Voltage: 120 VAC or 24 VAC/DC.

Latching Alarm: Reset by momentary power interruption.

Contact Nailor for minimum damper size and sleeve length for your specific application. See page C13 for general damper size, sleeve length and damper position guidelines.

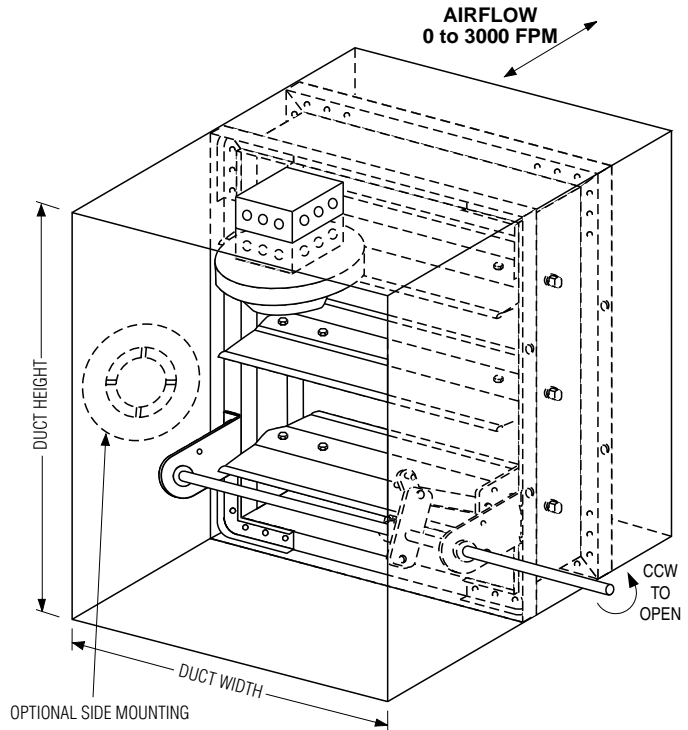

NOTES:

1. Factory mounted smoke detectors will be factory wired to actuator(s) (or E.P. switch) and heat sensor(s), as applicable, into a 4" x 4" (102 x 102) common junction box in order to provide a single point wiring connection in the field.

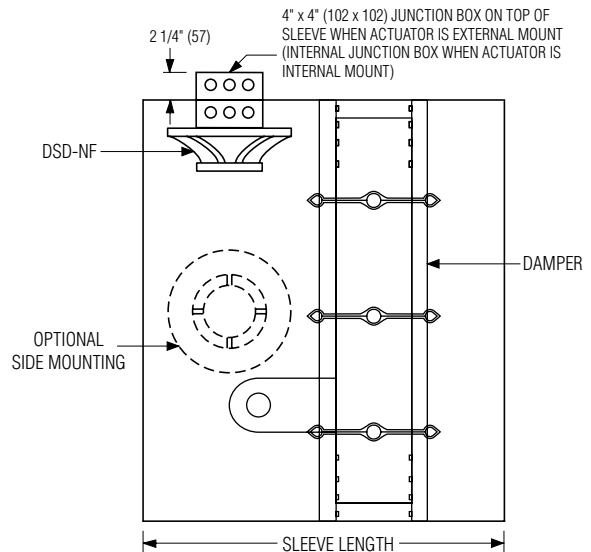

DUCT SMOKE DETECTORS:

OPTION CODE **DSDL**

DSD-LF LOW-FLOW
DUCT SMOKE DETECTOR

APPLICATION:

Nailor Model DSD-LF duct smoke detector (low-flow) can be utilized with Nailor UL555S Classified combination fire/smoke dampers to detect the presence of smoke within HVAC ductwork and close the damper to prevent the smoke from spreading. As most fatalities resulting from fires can be attributed to the effects of toxic smoke, detecting and controlling the smoke from spreading within the HVAC system is vital to preventing injury as well as limiting property damage, including damage to the HVAC system itself. Refer to NFPA Standards 72, 90A and 92A to determine when and where duct smoke detectors are required.

The DSD-NF detector can be factory installed to side of sleeve on Nailor Model Series 1220 and 1270 combination fire/smoke dampers.

A minimum airflow velocity of 100 fpm (0.5 m/s) is required for Model DSD-LF.

OPERATION:

Upon detection of smoke, the smoke detector causes the damper to close by cutting off power to the actuator. The actuator return spring forces the damper closed. The detector can be reset only by a momentary power interruption. The standard model DSD-LF detector and smoke damper combination is designed simply to close the damper upon detection of smoke. For applications requiring the detector to be wired into a fire fighters' smoke-control station (FSCS), contact Nailor.

DSD-LF STANDARD SPECIFICATION:

Model: System Sensor D4120.

Sensor Type: Photoelectric.

Dimensions: (Rectangular) 14.38" (365) Length, 5" (127) Width, 2.5" (64) Depth.

Weight: 2.5 lbs. (1.14 kg.).

Airflow Velocity Range: 100 to 4000 fpm (0.5 to 20.3 m/s).

Operating Temperature Range: -4°F to 158°F (-20°C to 70°C).

Operating Humidity Range: 0% to 95% Relative Humidity Non-Condensing.

Voltage: 24 VAC/DC or 120 VAC.

Contact Nailor for minimum damper size and sleeve length for your specific application. See page C13 for general damper size, sleeve length and damper position guidelines.

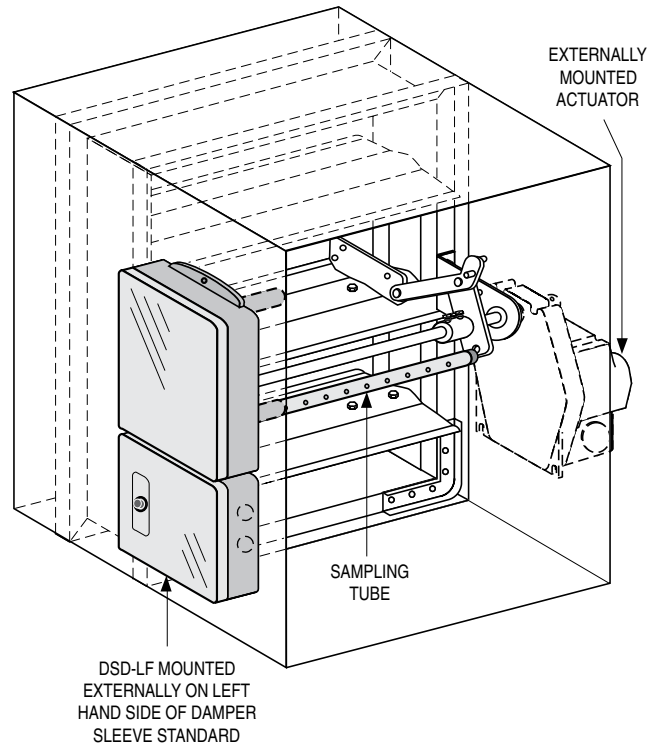

NOTES:

1. Smoke detector is factory mounted externally on left side of sleeve (opposite side of sleeve to the actuator) and will be mounted horizontally on dampers under 20" (508) in height and mounted vertically on dampers 20" (508) in height and over. See orientation details below.
2. Factory mounted smoke detectors will be factory wired to actuator(s) (or E.P. switch) and heat sensor(s), as applicable, into a 4" x 4" (102 x 102) common junction box in order to provide a single point wiring connection in the field.

