

## LINEAR SLOT DIFFUSER PLENUMS FOR TECHZONE™ TYPE CEILING

Model Series 5300TZ Plenums are designed to fit the 5000TZ Series Slot Diffusers. The plenums are constructed from corrosion-resistant steel and are available in two different styles for an extensive performance range.

Available choice of 1 to 4 slots are available to suit capacity requirements and three frame styles for Armstrong® TechZone™ and USG Logix™ ceiling systems. The standard constructed plenum is suited for applications that require longer throws and shorter spreads, whereas the modified plenum increases the spread and reduces the throw. Specially designed end caps can be turned up for continuous runs. All styles are offered with internal or external insulation.

### Standard Performance (non-insulated) –

Model 5375TZ

Page B30

### Standard Performance (internally insulated) –

Model 5375TZI

Page B30

### Modified Performance (non-insulated) –

Models 5375TZMP

Page B30

### Modified Performance (internally insulated) –

Models 5375TZIMP, 5310TZIMP, 5315TZIMP

Page B30

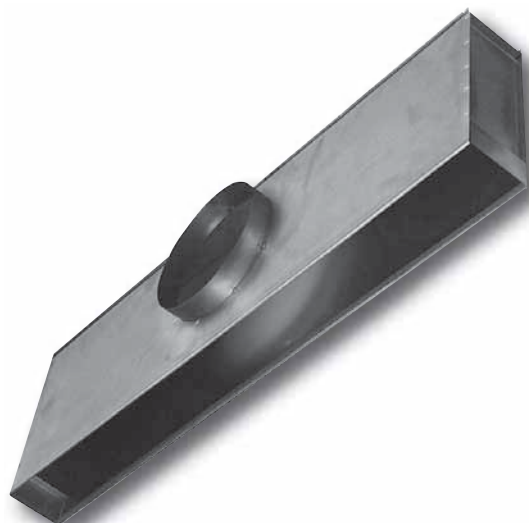

Model 5375TZ



Models 49-240, 49-280 and 49-480

## LINEAR BAR GRILLES

4900 Series provides an extruded aluminum bar grille that offers beautiful styling and efficient performance.

Linear bar grilles offer a choice of fixed air patterns with 0°, 15° or 30° air deflection, a choice of bar widths and spacing and a wide choice of border/frame style combinations to suit most types of installation. They are available with an optional opposed blade damper for volume control. Linear bar grilles are recommended for supply air applications in floors, window sills, and high sidewall locations. They are not generally suited to ceiling mounted supply applications (other than for directional spot heating or cooling as an air curtain) as they are not designed for horizontal projection from the face.

Models 49-240, 49-241, 49-243, 49-280, 49-281, 49-480, 49-481

Suffix '-O' adds a steel OBD.

Page B47

## LINEAR LOUVER DIFFUSERS

48LL Series Linear Louver (Vane) Diffusers are designed to provide a high capacity, architecturally pleasing linear diffuser that can supply large volumes of air at relatively low sound levels and pressure drops.

High quality, extruded aluminum angular discharge louvers are designed to create a stable horizontal air pattern that is tight to the ceiling. Ideal for applications in VAV systems, these diffusers create a strong ceiling coanda effect at typical maximum and minimum flow rates and ensure optimal comfort conditions.

Models 48LL, 48LL2

Page B66

Suffix '-O' adds a steel OBD.

Suffix '-OA' adds an aluminum OBD.

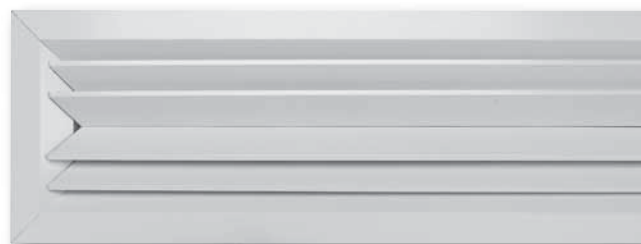

Models 48LL2 and 48LL1

## LINEAR BAR GRILLES

- STANDARD OR HEAVY DUTY MODELS
- SUITABLE FOR CEILING, SIDEWALL, SILL OR FLOOR INSTALLATIONS
- FIXED BARS
- 7 CORE STYLES
- ALUMINUM CONSTRUCTION

### 1/2" (13) Bar Spacing Models:

- 49-240 • 1/4" (6) Bars • 0° Deflection • Pencil-Proof
- 49-241 • 1/4" (6) Bars • 15° Deflection • Pencil-Proof
- 49-243 • 1/4" (6) Bars • 30° Deflection • Pencil-Proof
- 49-280 • 1/8" (3) Bars • 0° Deflection
- 49-281 • 1/8" (3) Bars • 15° Deflection

### 1/4" (6) Bar Spacing Models:

- 49-480 • 1/8" (3) Bars • 0° Deflection
- 49-481 • 1/8" (3) Bars • 15° Deflection
- Suffix 'O' adds a steel opposed blade damper

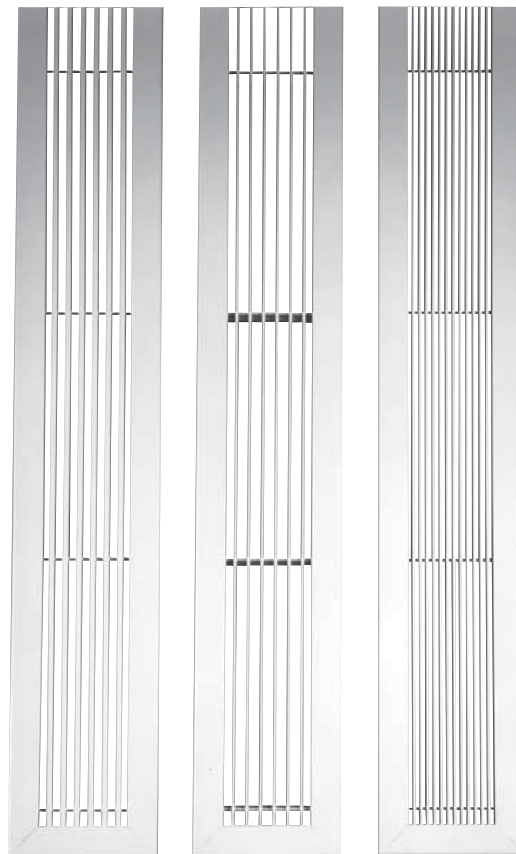

Models 49-240, 49-280, 49-480

Model Series 4900 Linear Bar Grilles have been specially designed to provide the precision quality appearance required for architectural excellence with crisply sculptured styling, careful workmanship and effective air distribution. Designed for heating and cooling applications, supply and return, the grilles are manufactured with precision mitered corners to maximize quality.

### STANDARD FEATURES:

- Deflection bars are fixed and are parallel to the long dimension.
- Available in 7 core styles and a variety of frame and sub-frame options.
- Diffusers are supplied in lengths of up to 6 ft. (1829) in a single section.
- Standard incremental units of length are 1, 2, 3, 4, 5 and 6 ft. (305, 610, 914, 1219, 1524 and 1829 mm). However, the 4900 Series is available in any nominal length to suit engineering and architectural requirements.
- Ideal for continuous length applications.
- Multiple sections are provided with alignment strips on the frame and sub-frame to provide superior, positive field alignment.
- End caps are staked and mitered for a superior quality appearance.
- Standard duty models are available for ceiling, wall or sill installations. Heavy duty models are designed specifically for use in floor installations.

### CONSTRUCTION MATERIAL:

Extruded Aluminum.

### FINISH OPTIONS:

- AW Appliance White frame is standard. Optional finish is AL Aluminum. Premium finishes are SA Satin (clear) Anodized or BC Brushed and Clear Coat lacquer.
- Other finishes are available.

### OPTIONS & ACCESSORIES:

- Heavy gauge steel opposed blade damper (add suffix '-O').
- HC Heavy Duty Core.
- DV Rear directional control vanes.
- MC Mitered Corner Sections.
- AD Access Doors.
- BO Blank-offs.

## DIMENSIONAL DATA: STANDARD DUTY FRAME TYPES

LINEAR DIFFUSERS AND BAR GRILLES

<p><b>TYPE A</b> 1" (25) Border</p> <p>Standard Frame</p>	<p><b>TYPE B</b> 3/4" (19) Reduced Border</p>	<p><b>TYPE C</b> 1" (25) Border and Sub-Frame</p>
<p><b>TYPE D</b> 1" (25) Border Deep Stack (permits DV option)</p>	<p><b>TYPE E</b> 1/2" (13) Narrow Border</p>	

## HEAVY DUTY MOUNTING FRAMES FLOOR INSTALLATIONS

<p><b>TYPE F</b> 1" (25) Border Flange</p> <p>Removable core with frame.</p>	<p><b>TYPE G</b> No Flange Flush Mounting</p> <p>Removable core with frame.</p>	<p><b>TYPE H</b> 3/4" (19) Bevelled Border</p> <p>Removable core with frame.</p>
--	---	--

## CEILING INSTALLATIONS

<p><b>TYPE K</b> 1" (25) Tape &amp; Spackle Border</p>
--

## DIMENSIONAL DATA:

### AVAILABLE CORE STYLES

#### MODEL 49-240

1/2" (13) Spacing • 1/4" (6) Bars • 0° Deflection  
"Pencil Proof"

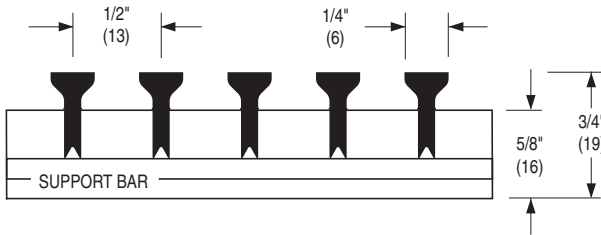

#### MODEL 49-241

1/2" (13) Spacing • 1/4" (6) Bars • 15° Deflection  
"Pencil Proof"

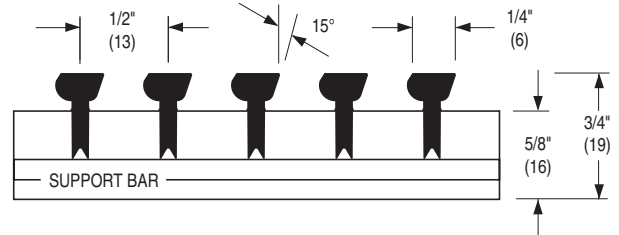

#### MODEL 49-243

1/2" (13) Spacing • 1/4" (6) Bars • 30° Deflection  
"Pencil Proof"

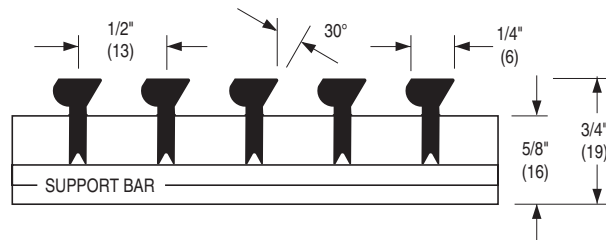

#### MODEL 49-280

1/2" (13) Spacing • 1/8" (3) Bars • 0° Deflection

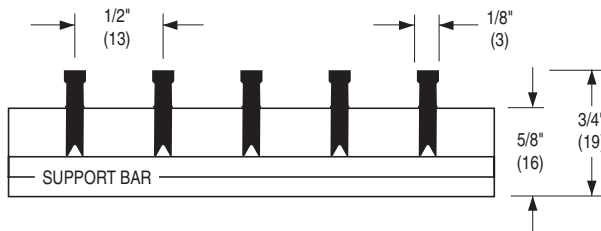

#### MODEL 49-281

1/2" (13) Spacing • 1/8" (3) Bars • 15° Deflection

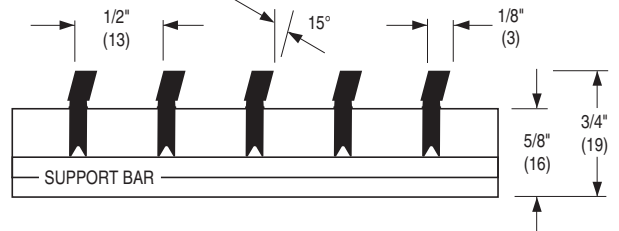

#### MODEL 49-480

1/4" (6) Spacing • 1/8" (3) Bars • 0° Deflection  
"Heel Proof"

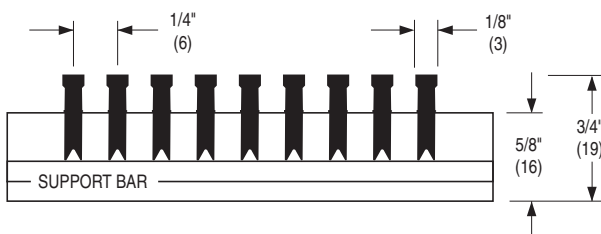

#### MODEL 49-481

1/4" (6) Spacing • 1/8" (3) Bars • 15° Deflection  
"Heel Proof"

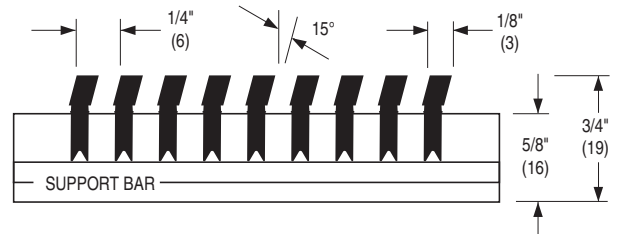

## DIMENSIONAL DATA:

### OVERALL LENGTH AND WIDTH

LINEAR DIFFUSERS AND BAR GRILLES

FRAME TYPES

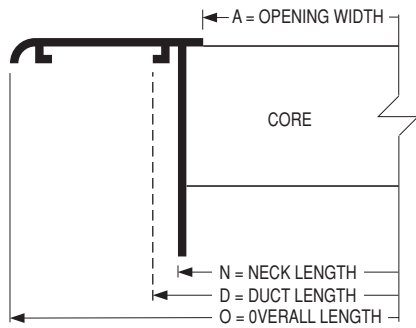

Type	N	O
A	D - 1/2" (13)	D + 1 1/2" (38)
B	D - 1/2" (13)	D + 1" (25)
D	D - 1/2" (13)	D + 1 1/2" (38)
E	D - 1/2" (13)	D + 1/2" (13)
F	D	D + 1 5/8" (41)
G	D	D
H	D	D + 1 1/8" (29)
K	D	D + 1 1/2" (38)

Dimensions are for length or width.

FRAME TYPES

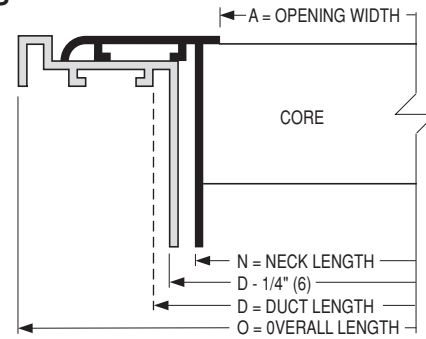

Type	N	O
C	D - 1/2" (13)	D + 2 1/8" (54)

Dimensions are for length or width.

### STANDARD WIDTHS AND CORE

Duct Width D	1/4" (6) Spacing	
	Opening Width A	Number of Bars
1 1/2" (38)	3/4" (19)	2
2" (51)	1 1/4" (32)	4
2 1/2" (64)	1 3/4" (44)	6
3" (76)	2 1/4" (57)	8
3 1/2" (89)	2 3/4" (70)	10
4" (102)	3 1/4" (83)	12
5" (127)	4 1/4" (108)	16
6" (152)	5 1/4" (133)	20

For frames types F, G, H & K increase the number of bars by two.  
Dimensions are in inches (mm).

Duct Width D	1/2" (13) Spacing	
	Opening Width A	Number of Bars
1 1/2" (38)	3/4" (19)	1
2" (51)	1 1/4" (32)	2
2 1/2" (64)	1 3/4" (44)	3
3" (76)	2 1/4" (57)	4
3 1/2" (89)	2 3/4" (70)	5
4" (102)	3 1/4" (83)	6
5" (127)	4 1/4" (108)	8
6" (152)	5 1/4" (133)	10

For frames types F, G, H & K increase the numbers of bars by one.

### CROSS-BAR SPACING

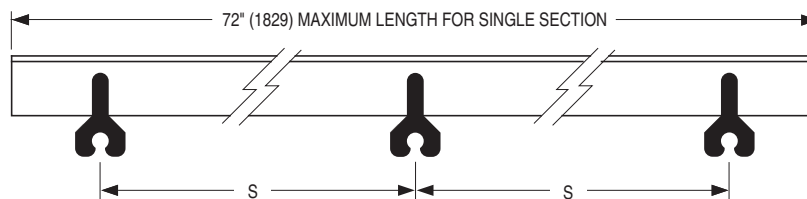

Standard Core: S = 12" (305) maximum support bar spacing. Frame Types A, B, C, D and E.

**Optional HC Heavy Duty Core:** S = 8" (203) maximum.

Standard for ceiling installations with frame type K and floor models with frame types F, G and H which also include secondary reinforcing support bars on 8" (203) maximum centers. Structural support designed and installed by others.

## DIMENSIONAL DATA:

### TYPICAL FRAME/CORE ASSEMBLIES

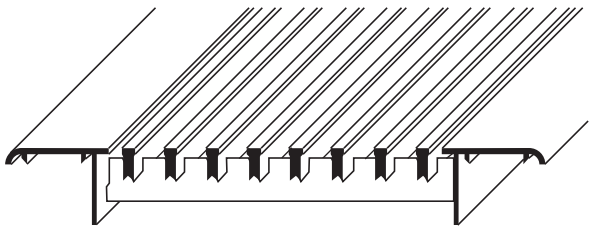
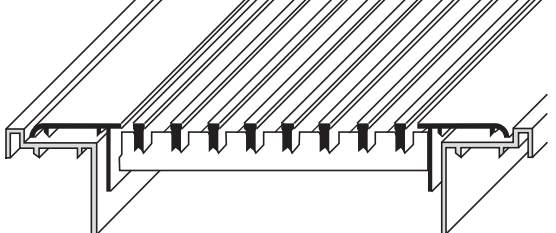
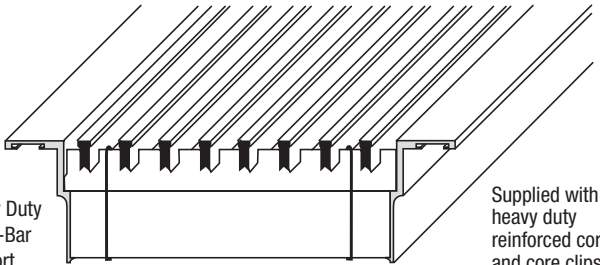
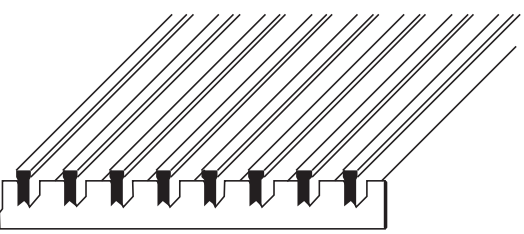
<p><b>CORE WITH FRAME</b></p>  <p><b>Type A Frame</b></p>	<p><b>CORE WITH FRAME &amp; SUB-FRAME</b></p>  <p><b>Type C Frame</b></p>
<p><b>CORE WITH HEAVY DUTY MOUNTING FRAME</b></p>  <p>Heavy Duty Cross-Bar Support</p> <p>Supplied with heavy duty reinforced core and core clips</p> <p><b>Type F Heavy Duty Mounting Frame</b></p>	<p><b>CORE ONLY NO FRAME</b></p>  <p><b>Type CO No Frame</b></p>

## FASTENINGS

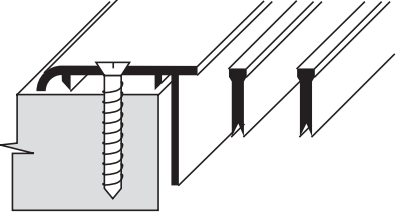
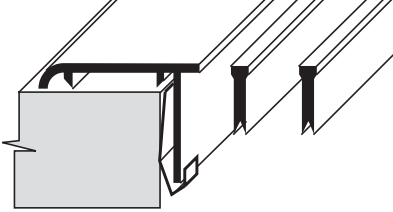
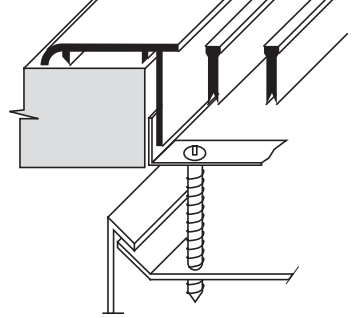
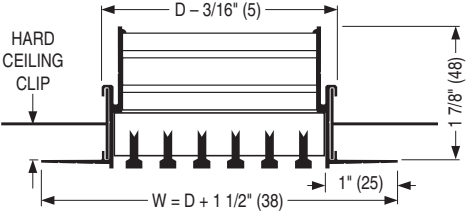
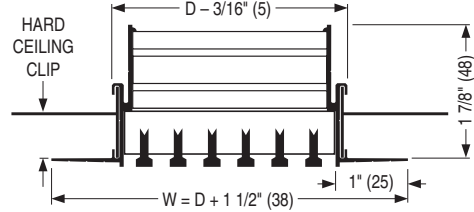
<p><b>TYPE A • COUNTERSUNK SCREW HOLES</b></p>  <p>For ceiling, side wall, sill or floor. Frame Types: A, B, C, D, F, K.</p>	<p><b>TYPE B • FRICTION SPRING CLIP</b></p>  <p>For sill installations. Frame Types: A, B, D, E, F, G, H.</p>	<p><b>TYPE C • CONCEALED MOUNTING</b></p>  <p>For ceiling, side wall, sill or floor. Frame Types: A, B, C, D, E. Not recommended for use with cores with 1/4" (6) bar spacing.</p>
<p><b>TYPE HC5 • HARD CEILING CLIPS</b></p>  <p>For 1/2" (13) drywall, frame type K only.</p>	<p><b>TYPE HC1 • HARD CEILING CLIPS</b></p>  <p>For 5/8" (16) drywall, frame type K only.</p>	

## DIMENSIONAL DATA:

### MITERED CORNER SECTIONS

49-240MC  
49-241MC  
49-243MC  
49-280MC

49-281MC  
49-480MC  
49-481MC

Factory welded with precision to match and align with the associated straight leg.  
Standard mitered corner section for floor, ceiling or wall is 90°. Other angles are available.

#### SPECIAL MITERED CORNERS:

\*Available from 45° – 179° as SPL. (A detailed sketch is required for co-ordination with installing contractors).

#### APPLICATION PATTERN

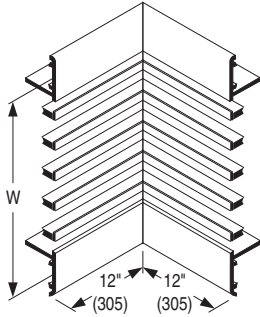

Type WC – Sidewall, inside

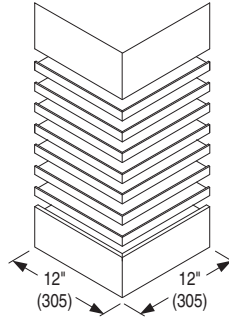

Type WD – Sidewall, outside

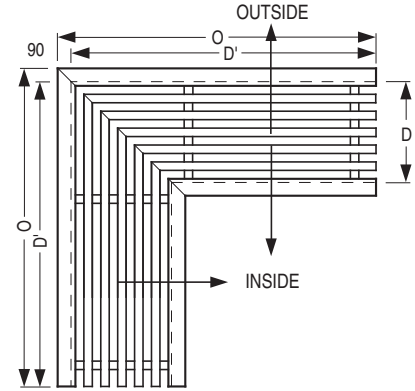

#### Floor, Ceiling or Sill

- Type FO • 0° deflection
- Type FA • Deflection inside
- Type FB • Deflection outside

#### 90° Mitered Corner Dimension 'O'

Duct Width D	Duct Length D'	Frame Type							
		A, D	B	C	E	F	G	H	K
1 1/2" – 4"	12"	12 3/4" (324)	12 1/2" (318)	13 1/16" (332)	12 1/4" (311)	12 13/16" (325)	12" (305)	12 9/16" (319)	12 3/4" (324)
4 1/2" – 12"	18"	18 3/4" (476)	18 1/2" (470)	19 1/16" (484)	18 1/4" (464)	18 13/16" (478)	18" (457)	18 9/16" (471)	18 3/4" (476)

## CONTINUOUS RUN DIMENSIONS

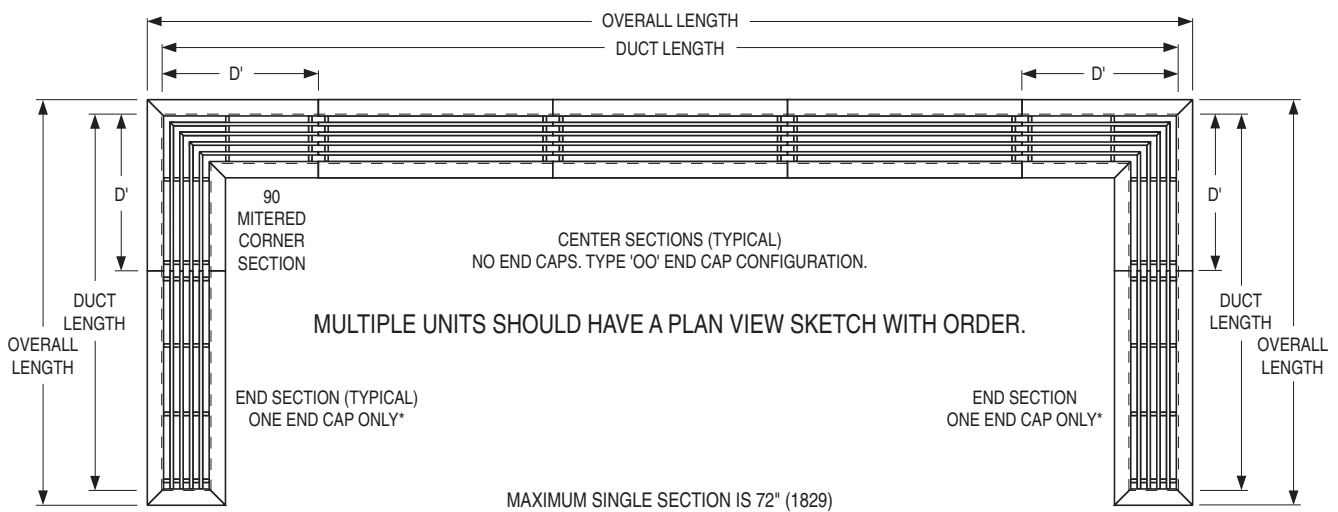

\* End sections with single end caps and deflecting cores must be specified and ordered with the desired core deflection direction. End cap configurations (mitered end cap one end and open opposite end):

Type 'MO' = 0° deflection

Type 'MU' = 15° or 30°



Type 'MD' = 15° or 30°



## DIMENSIONAL DATA: TYPICAL OPENING PREPARATIONS

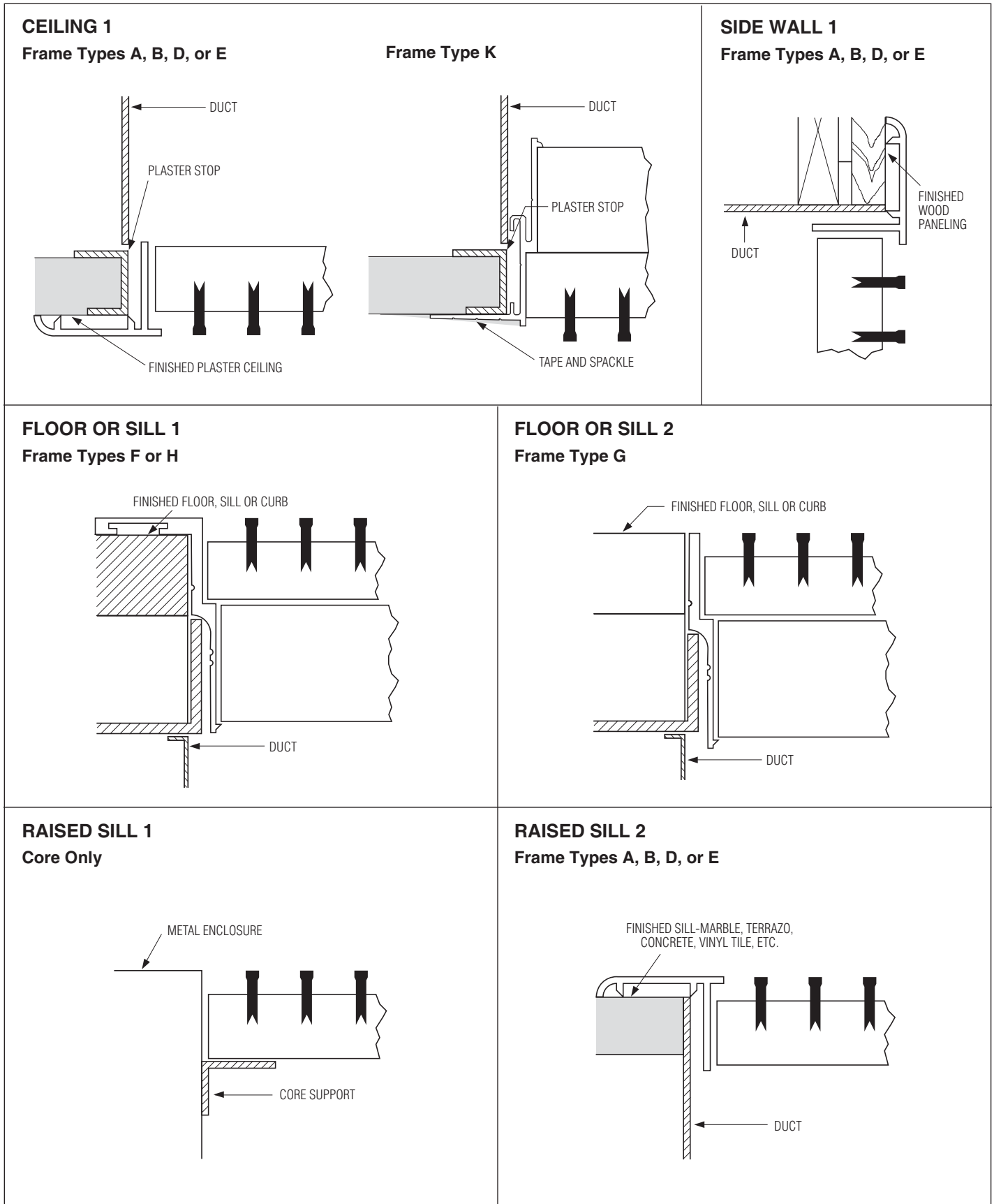



## ACCESSORIES:

### MODEL SERIES 4900

B LINEAR DIFFUSERS AND BAR GRILLES

#### TYPE DV DIRECTIONAL VANES

For widths 3" (76) and larger. Fully adjustable extruded aluminum blades on 3/4" (19) centers perpendicular to length.

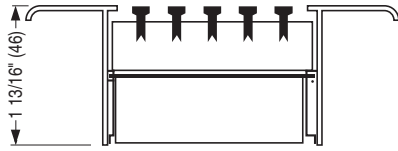

Requires Frame Type D (deep stack), F, G, H or K.

#### TYPE HC HEAVY DUTY CORE

Standard with Heavy duty mounting frame types F, G, H and K. Optional heavy duty core has cross bars on 8" (203) maximum centers (standard duty core is 12" [305]). Structural support designed and installed by others.

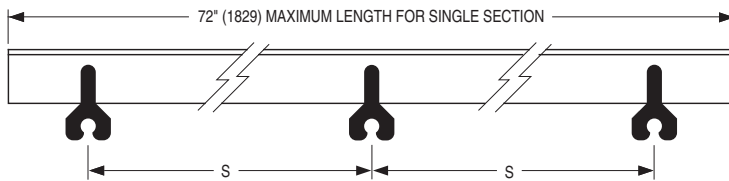

#### TYPE O SINGLE BLADE DAMPER

Friction hinge on 1 1/2" (38) and 2" (51) widths. Screwdriver operator on 2 1/2" (64) through 4" (102).

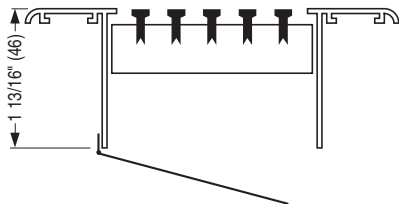

#### TYPE OBD OPPOSED BLADE DAMPER

For linear bar grilles with a nominal duct width of 2 1/2" (64) and wider.

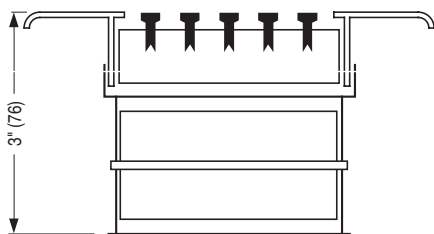

#### ALIGNMENT STRIPS

Supplied as standard on multiple-section assemblies to provide positive and accurate field alignment, except frame G which uses alignment pins.

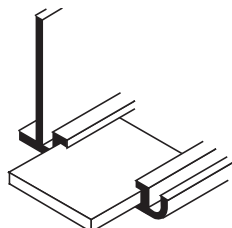

#### TYPE BO STEEL BLANK-OFF

For all available widths. Supplied in 6' (1829) lengths for field cutting. Steel, painted black.



#### ACCESS DOORS

(Not available with Heavy Duty Frame/Border Types F, G, H or K).

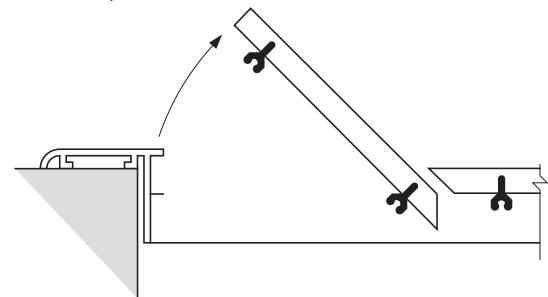

□ Type AD1L (left side)

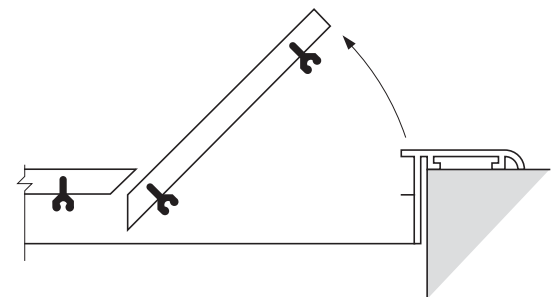

□ Type AD1R (right side)

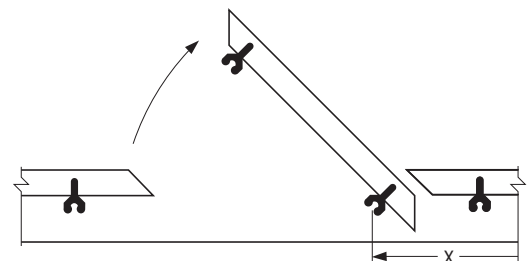

#### CENTER SECTION:

Type AD3L                      Type AD3R (not shown)

Specify 'X' dim.:

(distance from end of grille frame): \_\_\_\_\_ .

Access door is a 6" (152) core section hinged on one side. When selected with a deflected core, specify deflection:

Sill/ - To the front  
Floor - To the rear

Wall - Up  
Wall - Down

## HEAVY DUTY MAXIMUM FLOOR LOADING: FRAMES F, G, H • ALUMINUM REMOVABLE CORE

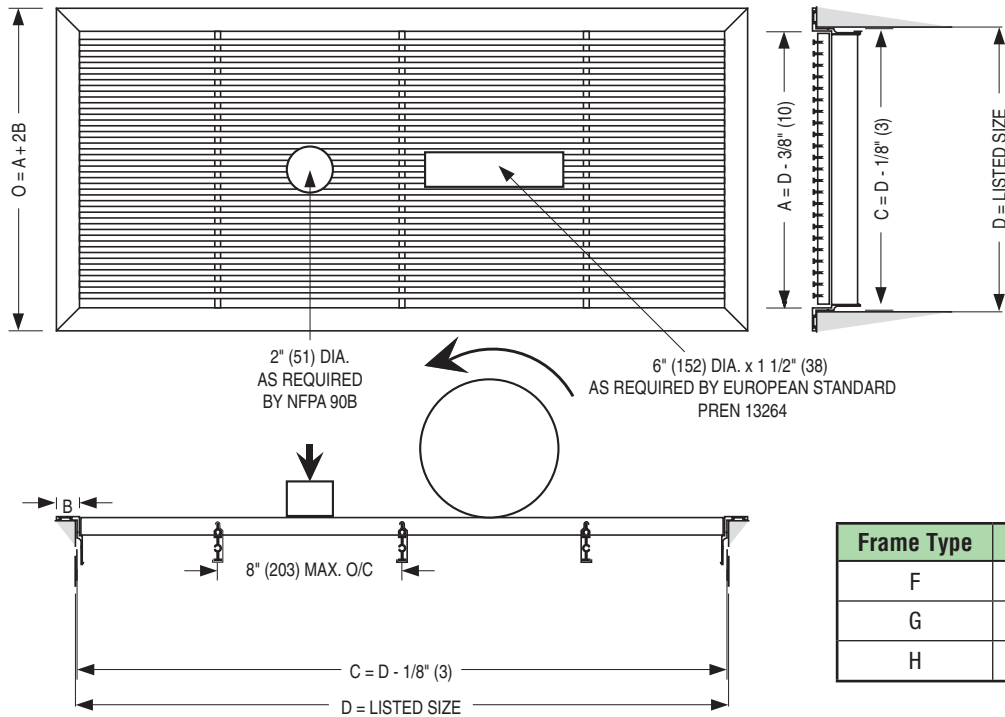

### MAXIMUM RECOMMENDED FLOOR LOADING

Model Number	Concentrated Load lbs (kg)	Rolling Load lbs (kg)
49-480, 49-481	500 (227)	350 (159)
49-240, 49-241, 49-243	500 (227)	300 (136)
49-280, 49-281	300 (136)	250 (113)

### DESCRIPTION:

1. Test results are based on standard construction heavy duty bar grilles with frame types F, G or H and with the standard core types as shown in the table. Support bars are spaced on maximum 8" (203) centers and units tested are with a maximum nominal duct width of 12" (305).
2. The maximum recommended load values shown in the chart represent the load that can be applied to the product without permanent deflection of the grille bars. The required load for actual structure failure is generally 2 to 5 times greater.
3. Concentrated load test is in accordance with NFPA 90B. Units were tested with a concentrated load on a 2" (51) diameter disk applied to the most critical area of the exposed face of the bar grille. In accordance with the standard the tests were conducted at an elevated temperature of 165° F (74° C). The standard requires the grilles to resist, without structural failure a concentrated load of 200 lbs (90.7 kg).

4. Rolling load test is in accordance with European Standard prEN 13264. Units were tested at the load shown with a 6" (152) diameter 1.5" (38) wide nylon wheel, traversed across the grille and supporting structure at 66 fpm (0.33 m/s) a minimum of 25 times in both the horizontal and vertical directions without structural failure.

## PERFORMANCE DATA:

### MODEL 49-240 • 1/2" (13) SPACING • 1/4" (6) BARS • 0° DEFLECTION

**B** LINEAR DIFFUSERS AND BAR GRILLES

Free Area Square Feet per Lineal Foot	Nominal Duct Width	Total Pressure	.010	.022	.039	.062	.087	.119	.156	.198	.245	
<b>.026</b>	<b>1 1/2"</b>	Airflow, CFM/FT.	<b>10</b>	<b>16</b>	<b>21</b>	<b>26</b>	<b>31</b>	<b>36</b>	<b>42</b>	<b>47</b>	<b>52</b>	
		Noise Criteria	-	-	-	19	24	30	34	37	40	
		Throw	Sill or Floor	1-1-1	2-2-2	4-4-4	7-7-7	8-9-10	10-11-12	11-12-14	12-14-16	14-16-18
			Side Wall	2-4-6	4-7-10	5-9-13	7-12-17	8-13-19	10-16-22	11-17-24	12-19-26	14-21-29
<b>.045</b>	<b>2"</b>	Airflow, CFM/FT.	<b>18</b>	<b>27</b>	<b>36</b>	<b>45</b>	<b>54</b>	<b>63</b>	<b>72</b>	<b>81</b>	<b>90</b>	
		Noise Criteria	-	-	-	18	23	29	33	36	39	
		Throw	Sill or Floor	1-1-1	4-4-4	7-7-7	9-9-10	10-11-13	13-14-16	14-16-18	15-17-20	17-19-21
			Side Wall	3-5-7	5-9-12	7-11-16	9-14-20	11-17-23	13-19-26	14-21-28	15-22-30	17-25-33
<b>.066</b>	<b>2 1/2"</b>	Airflow, CFM/FT.	<b>26</b>	<b>40</b>	<b>53</b>	<b>66</b>	<b>79</b>	<b>92</b>	<b>106</b>	<b>119</b>	<b>132</b>	
		Noise Criteria	-	-	-	20	26	31	35	38	41	
		Throw	Sill or Floor	2-2-2	6-6-6	8-8-9	11-12-13	13-14-16	15-17-19	18-20-22	21-22-23	22-23-24
			Side Wall	4-6-9	6-9-12	8-12-17	11-16-22	13-19-25	15-21-28	18-25-32	21-28-36	22-30-39
<b>.088</b>	<b>3"</b>	Airflow, CFM/FT.	<b>35</b>	<b>53</b>	<b>70</b>	<b>88</b>	<b>106</b>	<b>123</b>	<b>141</b>	<b>158</b>	<b>176</b>	
		Noise Criteria	-	-	15	21	27	32	36	39	42	
		Throw	Sill or Floor	2-2-2	7-7-7	10-10-11	12-13-15	15-16-18	18-19-21	20-22-24	24-24-25	26-26-27
			Side Wall	5-7-10	7-11-15	10-14-19	12-17-23	15-21-27	18-24-31	20-27-34	24-31-39	26-34-41
<b>.110</b>	<b>3 1/2"</b>	Airflow, CFM/FT.	<b>44</b>	<b>66</b>	<b>88</b>	<b>110</b>	<b>132</b>	<b>154</b>	<b>176</b>	<b>198</b>	<b>220</b>	
		Noise Criteria	-	-	16	22	28	33	37	40	43	
		Throw	Sill or Floor	3-3-3	8-8-8	12-12-12	15-15-16	18-19-20	20-21-22	23-24-25	25-26-27	29-29-29
			Side Wall	5-7-10	9-12-16	12-16-20	15-20-25	18-23-28	20-26-32	23-29-36	25-32-39	29-36-43
<b>.133</b>	<b>4"</b>	Airflow, CFM/FT.	<b>53</b>	<b>80</b>	<b>106</b>	<b>133</b>	<b>160</b>	<b>186</b>	<b>213</b>	<b>239</b>	<b>266</b>	
		Noise Criteria	-	-	17	23	29	34	38	41	44	
		Throw	Sill or Floor	3-3-3	9-9-9	13-13-13	16-16-17	20-20-21	22-23-24	24-25-26	28-28-28	31-31-31
			Side Wall	6-8-11	10-13-17	13-17-21	16-21-26	20-25-30	22-28-34	24-30-37	28-35-41	31-38-45
<b>.177</b>	<b>5"</b>	Airflow, CFM/FT.	<b>71</b>	<b>106</b>	<b>142</b>	<b>177</b>	<b>212</b>	<b>248</b>	<b>283</b>	<b>318</b>	<b>354</b>	
		Noise Criteria	-	-	18	24	30	35	39	42	45	
		Throw	Sill or Floor	4-4-4	10-10-10	15-15-15	18-18-18	22-22-23	25-25-25	27-27-28	30-30-30	34-34-34
			Side Wall	8-10-13	11-14-18	15-19-23	18-22-27	22-27-32	25-31-37	27-33-39	30-37-43	34-41-47
<b>.222</b>	<b>6"</b>	Airflow, CFM/FT.	<b>89</b>	<b>133</b>	<b>178</b>	<b>222</b>	<b>266</b>	<b>310</b>	<b>355</b>	<b>400</b>	<b>444</b>	
		Noise Criteria	-	-	20	25	31	36	40	43	46	
		Throw	Sill or Floor	5-5-5	10-10-10	15-15-15	19-19-19	23-23-23	25-25-25	29-29-29	31-31-31	36-36-36
			Side Wall	9-11-14	13-16-20	16-20-24	20-24-29	24-29-34	28-33-39	30-35-40	34-40-45	38-44-49

#### Performance Notes:

- Throws are given at 150, 100 and 50 fpm terminal velocities.
- Throw values are based on a 4 foot section with a cooling ΔT of 20°F (11°C). For other lengths, use the correction factor table shown.
- Total Pressure is in inches w.g..
- Noise Criteria [NC] values are based on a 10 foot active section. For other lengths, use the correction factor table shown.
- Return Air Applications:  
Noise Criteria value is increased by + 4.  
Negative Static Pressure = 0.8 x Total Pressure.
- Dash (-) in space indicates an Noise Criteria level of less than 15.
- Data derived from tests conducted in accordance with ANSI/ASHRAE Standard 70-2006.

#### Noise Criteria Correction for Length

Active Length, ft.	1	2	4	8	10	15	20
Correction Factor	-10	-7	-4	-1	0	+2	+3

#### Throw Correction for Length

Active Length	Terminal Velocity		
	150 fpm	100 fpm	50 fpm
1 ft.	0.5	0.6	0.7
10 ft. +	1.6	1.4	1.2

Nominal Width	Ak Factor per foot	
	Supply	Return
<b>1 1/2"</b>	.035	.030
<b>2"</b>	.054	.046
<b>2 1/2"</b>	.075	.064
<b>3"</b>	.098	.083
<b>3 1/2"</b>	.120	.102
<b>4"</b>	.143	.121
<b>5"</b>	.187	.159
<b>6"</b>	.233	.198

## PERFORMANCE DATA:

### MODEL 49-241 • 1/2" (13) SPACING • 1/4" (6) BARS • 15° DEFLECTION

Free Area Square Feet per Lineal Foot	Nominal Duct Width	Total Pressure	.012	.025	.047	.074	.105	.142	.187	.237	.294
<b>.031</b>	<b>1 1/2"</b>	Airflow, CFM/FT.	12	19	25	31	37	43	50	56	62
		Noise Criteria	–	16	24	32	37	42	46	49	52
		Throw	Sill or Floor Side Wall	1-1-1 2-4-6	3-3-3 4-7-10	5-5-5 6-10-14	7-7-7 7-12-17	9-9-10 9-14-20	10-11-12 10-16-23	12-13-15 12-18-25	13-15-17 13-20-27
<b>.048</b>	<b>2"</b>	Airflow, CFM/FT.	19	29	38	48	58	67	77	86	96
		Noise Criteria	–	–	20	27	32	37	41	44	47
		Throw	Sill or Floor Side Wall	1-1-1 3-5-7	4-4-4 5-8-12	7-7-7 7-11-16	9-9-10 9-14-20	11-12-13 11-17-24	13-14-15 13-19-26	15-16-18 15-22-29	16-18-20 16-23-31
<b>.067</b>	<b>2 1/2"</b>	Airflow, CFM/FT.	27	40	54	67	80	94	107	120	134
		Noise Criteria	–	–	20	27	32	37	41	44	47
		Throw	Sill or Floor Side Wall	1-1-1 4-6-8	5-5-5 6-9-13	9-9-9 9-13-17	11-11-12 11-16-21	13-14-15 14-19-25	15-16-18 15-21-27	17-19-21 17-24-31	20-21-22 20-27-35
<b>.086</b>	<b>3"</b>	Airflow, CFM/FT.	34	52	69	86	103	120	138	155	172
		Noise Criteria	–	–	20	27	32	37	41	44	47
		Throw	Sill or Floor Side Wall	2-2-2 4-6-9	6-6-6 8-11-15	10-10-11 10-14-19	12-13-14 13-18-23	15-16-18 16-21-27	18-19-20 18-24-31	20-21-23 21-28-35	23-24-25 23-30-38
<b>.105</b>	<b>3 1/2"</b>	Airflow, CFM/FT.	42	63	84	105	126	147	168	189	210
		Noise Criteria	–	–	20	28	33	38	42	45	48
		Throw	Sill or Floor Side Wall	2-2-2 6-8-11	8-8-8 9-12-16	11-11-12 12-16-21	15-15-15 14-19-24	17-18-19 18-23-29	21-21-22 21-27-33	22-23-25 23-29-36	25-25-26 25-32-39
<b>.127</b>	<b>4"</b>	Airflow, CFM/FT.	51	76	102	127	152	178	203	228	254
		Noise Criteria	–	–	21	29	34	39	43	46	49
		Throw	Sill or Floor Side Wall	3-3-3 6-9-12	9-9-9 10-13-17	13-13-13 13-17-22	16-16-17 15-20-25	19-20-21 19-24-30	22-22-23 22-28-34	24-25-26 25-31-38	27-27-27 28-36-41
<b>.167</b>	<b>5"</b>	Airflow, CFM/FT.	67	100	134	167	200	234	267	301	334
		Noise Criteria	–	–	21	29	34	39	43	46	49
		Throw	Sill or Floor Side Wall	4-4-4 8-11-14	10-10-10 11-15-19	14-14-14 15-19-24	18-18-18 19-23-28	21-21-22 21-26-32	24-24-25 24-30-36	26-27-28 26-32-39	30-30-30 29-36-42
<b>.210</b>	<b>6"</b>	Airflow, CFM/FT.	84	126	168	210	252	294	336	378	420
		Noise Criteria	–	15	23	31	36	41	45	48	51
		Throw	Sill or Floor Side Wall	5-5-5 9-12-15	10-10-10 14-17-21	15-15-15 17-21-25	19-19-19 20-24-29	23-23-23 24-29-34	25-25-25 27-32-38	28-28-29 29-35-40	31-31-31 32-38-43

#### Performance Notes:

- Throws are given at 150, 100 and 50 fpm terminal velocities.
- Throw values are based on a 4 foot section with a cooling  $\Delta T$  of 20°F (11°C). For other lengths, use the correction factor table shown.
- Total Pressure is in inches w.g..
- Noise Criteria [NC] values are based on a 10 foot active section. For other lengths, use the correction factor table shown.
- Return Air Applications:  
Noise Criteria value is increased by + 4.  
Negative Static Pressure = 0.8 x Total Pressure.
- Dash (–) in space indicates an Noise Criteria level of less than 15.
- Data derived from tests conducted in accordance with ANSI/ASHRAE Standard 70–2006.

#### Noise Criteria Correction for Length

Active Length, ft.	1	2	4	8	10	15	20
Correction Factor	-10	-7	-4	-1	0	+2	+3

#### Throw Correction for Length

Active Length	Terminal Velocity		
	150 fpm	100 fpm	50 fpm
1 ft.	0.5	0.6	0.7
10 ft. +	1.6	1.4	1.2

Nominal Width	Ak Factor per foot	
	Supply	Return
1 1/2"	.041	.037
2"	.058	.051
2 1/2"	.076	.066
3"	.095	.080
3 1/2"	.115	.098
4"	.137	.113
5"	.177	.148
6"	.230	.189

## PERFORMANCE DATA:

### MODEL 49-243 • 1/2" (13) SPACING • 1/4" (6) BARS • 30° DEFLECTION

Free Area Square Feet per Lineal Foot	Nominal Duct Width	Total Pressure	.012	.025	.047	.074	.105	.142	.187	.237	.294
<b>.031</b>	<b>1 1/2"</b>	Airflow, CFM/FT.	12	19	25	31	37	43	50	56	62
		Noise Criteria	–	16	24	32	37	42	46	49	52
		Throw	Sill or Floor	1-1-1	3-3-3	5-5-5	7-7-7	9-9-10	10-11-12	12-13-15	13-15-17
		Side Wall	2-4-6	4-7-10	6-10-14	7-12-17	9-14-20	10-16-23	12-18-25	13-20-27	14-22-30
<b>.048</b>	<b>2"</b>	Airflow, CFM/FT.	19	29	38	48	58	67	77	86	96
		Noise Criteria	–	–	20	27	32	37	41	44	47
		Throw	Sill or Floor	1-1-1	4-4-4	7-7-7	9-9-10	11-12-13	13-14-15	15-16-18	16-18-20
		Side Wall	3-5-7	5-8-12	7-11-16	9-14-20	11-17-24	13-19-26	15-22-29	16-23-31	17-25-34
<b>.067</b>	<b>2 1/2"</b>	Airflow, CFM/FT.	27	40	54	67	80	94	107	120	134
		Noise Criteria	–	–	20	27	32	37	41	44	47
		Throw	Sill or Floor	1-1-1	5-5-5	9-9-9	11-11-12	13-14-15	15-16-18	17-19-21	20-21-22
		Side Wall	4-6-8	6-9-13	9-13-17	11-16-21	14-19-25	15-21-27	17-24-31	20-27-35	22-29-38
<b>.086</b>	<b>3"</b>	Airflow, CFM/FT.	34	52	69	86	103	120	138	155	172
		Noise Criteria	–	–	20	27	32	37	41	44	47
		Throw	Sill or Floor	2-2-2	6-6-6	10-10-11	12-13-14	15-16-18	18-19-20	20-21-23	23-24-25
		Side Wall	4-6-9	8-11-15	10-14-19	13-18-23	16-21-27	18-24-31	21-28-35	23-30-38	26-34-41
<b>.105</b>	<b>3 1/2"</b>	Airflow, CFM/FT.	42	63	84	105	126	147	168	189	210
		Noise Criteria	–	–	20	28	33	38	42	45	48
		Throw	Sill or Floor	2-2-2	8-8-8	11-11-12	15-15-15	17-18-19	21-21-22	22-23-25	25-25-26
		Side Wall	6-8-11	9-12-16	12-16-21	14-19-24	18-23-29	21-27-33	23-29-36	25-32-39	28-36-43
<b>.127</b>	<b>4"</b>	Airflow, CFM/FT.	51	76	102	127	152	178	203	228	254
		Noise Criteria	–	–	21	29	34	39	43	46	49
		Throw	Sill or Floor	3-3-3	9-9-9	13-13-13	16-16-17	19-20-21	22-22-23	24-25-26	27-27-27
		Side Wall	6-9-12	10-13-17	13-17-22	15-20-25	19-24-30	22-28-34	25-31-38	28-36-41	30-37-44
<b>.167</b>	<b>5"</b>	Airflow, CFM/FT.	67	100	134	167	200	234	267	301	334
		Noise Criteria	–	–	21	29	34	39	43	46	49
		Throw	Sill or Floor	4-4-4	10-10-10	14-14-14	18-18-18	21-21-22	24-24-25	26-27-28	30-30-30
		Side Wall	8-11-14	11-15-19	15-19-24	19-23-28	21-26-32	24-30-36	26-32-39	29-36-42	33-39-46
<b>.210</b>	<b>6"</b>	Airflow, CFM/FT.	84	126	168	210	252	294	336	378	420
		Noise Criteria	–	15	23	31	36	41	45	48	51
		Throw	Sill or Floor	5-5-5	10-10-10	15-15-15	19-19-19	23-23-23	25-25-25	28-28-29	31-31-31
		Side Wall	9-12-15	14-17-21	17-21-25	20-24-29	24-29-34	27-32-38	29-35-40	32-38-43	36-42-47

#### Performance Notes:

- Throws are given at 150, 100 and 50 fpm terminal velocities.
- Throw values are based on a 4 foot section with a cooling  $\Delta T$  of 20°F (11°C). For other lengths, use the correction factor table shown.
- Total Pressure is in inches w.g..
- Noise Criteria [NC] values are based on a 10 foot active section. For other lengths, use the correction factor table shown.
- Return Air Applications:  
Noise Criteria value is increased by +4.  
Negative Static Pressure = 0.8 x Total Pressure.
- Dash (–) in space indicates an Noise Criteria level of less than 15.
- Data derived from tests conducted in accordance with ANSI/ASHRAE Standard 70–2006.

#### Noise Criteria Correction for Length

Active Length, ft.	1	2	4	8	10	15	20
Correction Factor	-10	-7	-4	-1	0	+2	+3

#### Throw Correction for Length

Active Length	Terminal Velocity		
	150 fpm	100 fpm	50 fpm
1 ft.	0.5	0.6	0.7
10 ft. +	1.6	1.4	1.2

Nominal Width	Ak Factor per foot	
	Supply	Return
1 1/2"	.041	.037
2"	.058	.051
2 1/2"	.076	.066
3"	.095	.080
3 1/2"	.115	.098
4"	.137	.113
5"	.177	.148
6"	.230	.189

B

LINEAR DIFFUSERS AND BAR GRILLES

## PERFORMANCE DATA:

### MODEL 49-281 • 1/2" (13) SPACING • 1/8" (3) BARS • 15° DEFLECTION

**B** LINEAR DIFFUSERS AND BAR GRILLES

Free Area Square Feet per Lineal Foot	Nominal Duct Width	Total Pressure	.009	.020	.035	.056	.078	.107	.140	.178	.220	
<b>.039</b>	<b>1 1/2"</b>	Airflow, CFM/FT.	<b>16</b>	<b>23</b>	<b>31</b>	<b>39</b>	<b>47</b>	<b>55</b>	<b>62</b>	<b>70</b>	<b>78</b>	
		Noise Criteria	–	18	27	33	38	43	47	50	53	
		Throw	Sill or Floor	1-1-1	3-3-3	5-5-5	8-8-8	9-9-10	10-11-13	12-13-15	13-15-17	14-16-18
			Side Wall	2-4-6	4-7-10	6-10-14	8-13-18	9-14-20	10-16-23	12-18-25	13-20-27	14-22-30
<b>.056</b>	<b>2"</b>	Airflow, CFM/FT.	<b>22</b>	<b>34</b>	<b>45</b>	<b>56</b>	<b>67</b>	<b>78</b>	<b>90</b>	<b>101</b>	<b>112</b>	
		Noise Criteria	–	–	20	26	31	36	40	44	47	
		Throw	Sill or Floor	1-1-1	4-4-4	7-7-7	9-9-10	11-12-13	12-14-16	14-16-18	15-17-20	18-19-21
			Side Wall	3-5-7	5-8-12	7-11-16	9-14-20	11-17-23	12-18-25	14-20-27	15-22-30	18-26-34
<b>.075</b>	<b>2 1/2"</b>	Airflow, CFM/FT.	<b>30</b>	<b>45</b>	<b>60</b>	<b>75</b>	<b>90</b>	<b>105</b>	<b>120</b>	<b>135</b>	<b>150</b>	
		Noise Criteria	–	–	18	24	30	35	39	43	46	
		Throw	Sill or Floor	1-1-1	5-5-5	8-8-9	11-11-12	13-14-15	15-16-18	17-19-21	20-21-22	22-22-23
			Side Wall	4-6-8	6-9-13	8-12-17	11-16-21	13-19-25	15-21-27	17-24-31	20-27-35	22-30-38
<b>.093</b>	<b>3"</b>	Airflow, CFM/FT.	<b>37</b>	<b>56</b>	<b>74</b>	<b>93</b>	<b>112</b>	<b>130</b>	<b>149</b>	<b>167</b>	<b>186</b>	
		Noise Criteria	–	–	17	23	29	34	38	42	45	
		Throw	Sill or Floor	2-2-2	6-6-6	10-10-10	12-12-13	15-16-17	18-19-20	20-21-23	23-23-24	25-25-25
			Side Wall	4-6-9	7-10-14	10-13-18	12-17-22	15-20-26	18-24-30	20-26-33	23-30-37	25-32-39
<b>.113</b>	<b>3 1/2"</b>	Airflow, CFM/FT.	<b>45</b>	<b>68</b>	<b>90</b>	<b>113</b>	<b>136</b>	<b>158</b>	<b>181</b>	<b>203</b>	<b>226</b>	
		Noise Criteria	–	–	17	23	29	34	38	42	45	
		Throw	Sill or Floor	2-2-2	7-7-7	12-12-12	14-14-15	17-18-19	20-21-22	22-23-24	25-25-26	27-27-27
			Side Wall	5-7-10	8-11-15	12-16-20	14-18-23	17-22-27	20-25-31	22-28-35	25-32-39	27-34-41
<b>.133</b>	<b>4"</b>	Airflow, CFM/FT.	<b>53</b>	<b>80</b>	<b>106</b>	<b>133</b>	<b>160</b>	<b>186</b>	<b>212</b>	<b>239</b>	<b>266</b>	
		Noise Criteria	–	–	18	24	30	35	39	43	46	
		Throw	Sill or Floor	3-3-3	8-8-9	13-13-13	15-15-16	19-19-20	22-22-23	24-24-25	26-26-27	30-30-30
			Side Wall	6-8-11	9-12-16	13-17-21	15-19-24	19-24-29	22-27-33	24-30-36	26-33-39	30-37-43
<b>.173</b>	<b>5"</b>	Airflow, CFM/FT.	<b>69</b>	<b>104</b>	<b>138</b>	<b>173</b>	<b>208</b>	<b>242</b>	<b>277</b>	<b>312</b>	<b>346</b>	
		Noise Criteria	–	–	18	24	30	35	39	43	46	
		Throw	Sill or Floor	4-4-4	9-9-9	14-14-14	17-17-17	20-21-22	24-24-24	26-26-27	29-29-29	32-32-32
			Side Wall	8-10-13	11-14-18	15-19-23	17-21-26	20-25-31	24-29-35	26-33-38	29-35-41	32-39-45
<b>.212</b>	<b>6"</b>	Airflow, CFM/FT.	<b>85</b>	<b>127</b>	<b>170</b>	<b>212</b>	<b>254</b>	<b>296</b>	<b>339</b>	<b>382</b>	<b>424</b>	
		Noise Criteria	–	–	18	24	30	35	39	43	46	
		Throw	Sill or Floor	5-5-5	10-10-10	15-15-15	18-18-18	23-23-23	25-25-25	28-28-28	30-30-30	34-34-34
			Side Wall	9-11-14	13-16-20	16-20-24	20-24-28	23-27-32	25-30-36	28-33-39	31-37-42	35-41-46

#### Performance Notes:

- Throws are given at 150, 100 and 50 fpm terminal velocities.
- Throw values are based on a 4 foot section with a cooling ΔT of 20°F (11°C). For other lengths, use the correction factor table shown.
- Total Pressure is in inches w.g..
- Noise Criteria [NC] values are based on a 10 foot active section. For other lengths, use the correction factor table shown.
- Return Air Applications:  
Noise Criteria value is increased by + 4.  
Negative Static Pressure = 0.8 x Total Pressure.
- Dash (–) in space indicates an Noise Criteria level of less than 15.
- Data derived from tests conducted in accordance with ANSI/ASHRAE Standard 70–2006.

#### Noise Criteria Correction for Length

Active Length, ft.	1	2	4	8	10	15	20
Correction Factor	-10	-7	-4	-1	0	+2	+3

#### Throw Correction for Length

Active Length	Terminal Velocity		
	150 fpm	100 fpm	50 fpm
1 ft.	0.5	0.6	0.7
10 ft. +	1.6	1.4	1.2

Nominal Width	Ak Factor per foot	
	Supply	Return
<b>1 1/2"</b>	.052	.047
<b>2"</b>	.067	.060
<b>2 1/2"</b>	.086	.075
<b>3"</b>	.103	.091
<b>3 1/2"</b>	.123	.103
<b>4"</b>	.143	.126
<b>5"</b>	.183	.157
<b>6"</b>	.222	.188

## PERFORMANCE DATA:

### MODEL 49-480 • 1/4" (6) SPACING • 1/8" (3) BARS • 0° DEFLECTION

Free Area Square Feet per Lineal Foot	Nominal Duct Width	Total Pressure	.011	.024	.043	.068	.096	.130	.171	.218	.269	
.031	1 1/2"	Airflow, CFM/FT.	12	19	25	31	37	43	50	56	62	
		Noise Criteria	–	–	–	20	24	29	33	36	39	
		Throw	Sill or Floor	1-1-1	2-2-2	4-4-4	6-6-6	8-8-9	9-10-11	10-11-13	12-13-15	13-15-18
			Side Wall	2-4-6	4-7-10	6-9-13	7-11-16	8-13-19	9-15-21	10-16-23	12-18-25	13-20-28
.047	2"	Airflow, CFM/FT.	19	28	37	47	56	66	75	84	94	
		Noise Criteria	–	–	–	18	23	29	32	36	39	
		Throw	Sill or Floor	1-1-1	4-4-4	6-6-6	9-9-9	11-11-12	12-13-15	14-15-17	15-17-19	16-18-20
			Side Wall	3-5-7	5-8-11	7-11-15	9-14-19	11-16-22	12-18-25	14-20-27	15-22-29	16-24-32
.065	2 1/2"	Airflow, CFM/FT.	26	39	52	65	78	91	104	117	130	
		Noise Criteria	–	–	–	20	24	30	34	37	40	
		Throw	Sill or Floor	1-1-1	5-5-5	8-8-8	10-10-11	13-14-15	15-16-17	16-18-20	20-20-21	22-22-22
			Side Wall	4-6-8	6-9-12	8-12-16	10-15-20	13-18-24	15-21-27	16-22-30	20-27-34	22-30-38
.083	3"	Airflow, CFM/FT.	33	50	66	83	100	116	133	149	166	
		Noise Criteria	–	–	–	20	26	31	35	38	41	
		Throw	Sill or Floor	2-2-2	6-6-6	9-9-10	12-12-13	15-16-17	18-19-20	20-21-22	23-23-23	25-25-25
			Side Wall	4-6-9	7-10-14	9-13-18	12-17-22	15-20-25	18-23-29	20-26-33	23-30-37	25-32-39
.102	3 1/2"	Airflow, CFM/FT.	41	61	82	102	122	143	163	184	204	
		Noise Criteria	–	–	15	21	27	32	36	39	42	
		Throw	Sill or Floor	2-2-2	7-7-7	10-10-11	15-15-15	17-18-19	20-21-22	22-23-24	25-25-26	27-27-27
			Side Wall	5-7-10	8-11-15	10-15-20	15-19-24	17-22-27	20-25-31	22-28-35	25-32-39	27-34-41
.122	4"	Airflow, CFM/FT.	49	73	98	122	146	171	195	220	244	
		Noise Criteria	–	–	16	22	29	33	37	40	43	
		Throw	Sill or Floor	3-3-3	8-8-8	12-12-13	15-15-16	19-19-20	21-21-23	24-24-25	26-26-27	29-29-30
			Side Wall	6-8-11	9-12-16	12-16-20	15-20-25	19-24-29	21-26-32	24-30-36	26-33-39	30-37-46
.157	5"	Airflow, CFM/FT.	63	94	125	157	188	220	251	282	314	
		Noise Criteria	–	–	16	22	28	33	37	40	43	
		Throw	Sill or Floor	4-4-4	9-9-9	14-14-14	17-17-17	21-21-22	24-24-24	27-27-27	29-29-29	32-32-32
			Side Wall	7-9-12	11-14-18	14-18-22	17-21-26	21-26-31	24-29-35	27-33-39	30-36-42	33-40-46
.194	6"	Airflow, CFM/FT.	78	116	155	194	233	272	310	349	388	
		Noise Criteria	–	–	18	24	30	35	38	42	43	
		Throw	Sill or Floor	5-5-5	10-10-10	15-15-15	18-18-18	23-23-23	25-25-25	28-28-29	31-31-31	34-34-34
			Side Wall	8-10-13	12-15-19	15-19-23	20-24-28	23-27-32	26-31-37	29-34-39	33-39-44	37-43-48

#### Performance Notes:

- Throws are given at 150, 100 and 50 fpm terminal velocities.
- Throw values are based on a 4 foot section with a cooling  $\Delta T$  of 20°F (11°C). For other lengths, use the correction factor table shown.
- Total Pressure is in inches w.g..
- Noise Criteria [NC] values are based on a 10 foot active section. For other lengths, use the correction factor table shown.
- Return Air Applications:  
Noise Criteria value is increased by + 4.  
Negative Static Pressure = 0.8 x Total Pressure.
- Dash (–) in space indicates an Noise Criteria level of less than 15.
- Data derived from tests conducted in accordance with ANSI/ASHRAE Standard 70–2006.

#### Noise Criteria Correction for Length

Active Length, ft.	1	2	4	8	10	15	20
Correction Factor	-10	-7	-4	-1	0	+2	+3

#### Throw Correction for Length

Active Length	Terminal Velocity		
	150 fpm	100 fpm	50 fpm
1 ft.	0.5	0.6	0.7
10 ft. +	1.6	1.4	1.2

Nominal Width	Ak Factor per foot	
	Supply	Return
1 1/2"	.041	.034
2"	.056	.048
2 1/2"	.074	.064
3"	.092	.078
3 1/2"	.111	.098
4"	.131	.111
5"	.166	.143
6"	.203	.173



## PERFORMANCE DATA:

### MODEL 49-481 • 1/4" (6) SPACING • 1/8" (3) BARS • 15° DEFLECTION

B

LINEAR DIFFUSERS AND BAR GRILLES

Free Area Square Feet per Lineal Foot	Nominal Duct Width	Total Pressure	.012	.026	.049	.077	.109	.148	.195	.247	.304	
.034	1 1/2"	Airflow, CFM/FT.	14	20	27	34	41	48	54	61	68	
		Noise Criteria	-	-	22	30	35	39	43	46	49	
		Throw	Sill or Floor	1-1-1	3-3-3	4-4-4	7-7-7	9-9-10	10-11-12	12-13-15	13-14-16	14-16-18
			Side Wall	2-4-6	4-7-10	6-10-14	7-12-17	9-14-20	10-16-22	12-18-25	13-20-27	14-22-30
.049	2"	Airflow, CFM/FT.	20	29	39	49	59	69	78	88	98	
		Noise Criteria	-	-	20	27	32	37	41	44	47	
		Throw	Sill or Floor	1-1-1	4-4-4	6-6-6	9-9-9	11-11-12	12-13-15	14-16-18	15-17-19	16-18-20
			Side Wall	3-5-7	5-8-11	7-11-15	9-14-19	11-16-22	12-18-25	14-20-27	15-22-29	16-24-32
.065	2 1/2"	Airflow, CFM/FT.	26	39	52	65	78	91	104	117	130	
		Noise Criteria	-	-	20	27	32	37	41	44	47	
		Throw	Sill or Floor	1-1-1	5-5-5	8-8-8	10-10-11	13-14-15	14-15-17	17-18-20	19-20-21	21-21-22
			Side Wall	4-6-8	6-9-12	8-12-16	10-15-20	13-19-24	14-20-26	17-23-30	19-26-33	21-28-36
.082	3"	Airflow, CFM/FT.	33	49	66	82	98	115	131	148	164	
		Noise Criteria	-	-	20	27	32	37	41	44	47	
		Throw	Sill or Floor	2-2-2	6-6-6	9-9-9	12-12-13	15-15-16	17-18-19	20-21-22	21-22-23	23-23-24
			Side Wall	4-6-9	7-10-13	9-13-17	12-16-21	15-20-25	17-22-28	20-26-32	21-28-35	23-31-39
.099	3 1/2"	Airflow, CFM/FT.	40	59	79	99	119	138	158	178	198	
		Noise Criteria	-	-	20	28	33	37	41	44	47	
		Throw	Sill or Floor	2-2-2	8-8-8	11-11-11	13-13-14	16-17-18	19-20-21	22-22-23	23-24-25	26-26-26
			Side Wall	5-7-9	8-11-14	11-15-19	13-17-22	16-21-26	19-24-30	22-28-34	23-30-37	26-33-40
.117	4"	Airflow, CFM/FT.	47	70	94	117	140	164	187	220	234	
		Noise Criteria	-	-	21	28	34	38	42	45	48	
		Throw	Sill or Floor	3-3-3	9-9-9	12-12-12	15-15-15	18-19-20	21-21-22	23-24-25	25-25-26	28-28-28
			Side Wall	5-7-10	9-12-15	12-16-20	15-19-24	18-23-28	21-26-32	23-29-35	25-32-39	29-36-42
.152	5"	Airflow, CFM/FT.	61	91	121	152	182	212	243	274	304	
		Noise Criteria	-	-	22	29	34	39	43	46	49	
		Throw	Sill or Floor	3-3-3	9-9-9	13-13-13	16-16-17	20-20-21	23-23-24	25-25-26	28-28-28	31-31-31
			Side Wall	7-9-12	10-13-17	14-18-22	16-21-26	20-25-30	23-28-34	25-31-37	28-34-40	31-38-44
.186	6"	Airflow, CFM/FT.	74	111	149	186	223	260	298	335	372	
		Noise Criteria	-	-	22	30	35	40	43	47	50	
		Throw	Sill or Floor	4-4-4	10-10-10	14-14-14	18-18-18	22-22-22	25-25-25	28-28-28	30-30-30	33-32-32
			Side Wall	8-10-13	11-14-18	15-19-23	19-23-27	23-27-31	25-30-35	28-33-39	31-37-42	34-40-45

#### Performance Notes:

- Throws are given at 150, 100 and 50 fpm terminal velocities.
- Throw values are based on a 4 foot section with a cooling ΔT of 20°F (11°C). For other lengths, use the correction factor table shown.
- Total Pressure is in inches w.g..
- Noise Criteria [NC] values are based on a 10 foot active section. For other lengths, use the correction factor table shown.
- Return Air Applications:  
Noise Criteria value is increased by + 4.  
Negative Static Pressure = 0.8 x Total Pressure.
- Dash (-) in space indicates an Noise Criteria level of less than 15.
- Data derived from tests conducted in accordance with ANSI/ASHRAE Standard 70-2006.

#### Noise Criteria Correction for Length

Active Length, ft.	1	2	4	8	10	15	20
Correction Factor	-10	-7	-4	-1	0	+2	+3

#### Throw Correction for Length

Active Length	Terminal Velocity		
	150 fpm	100 fpm	50 fpm
1 ft.	0.5	0.6	0.7
10 ft. +	1.6	1.4	1.2

Nominal Width	Ak Factor per foot	
	Supply	Return
1 1/2"	.045	.041
2"	.059	.053
2 1/2"	.074	.065
3"	.091	.080
3 1/2"	.108	.091
4"	.126	.108
5"	.161	.138
6"	.195	.166



## HOW TO ORDER

### LINEAR BAR GRILLES – MODEL SERIES 4900

#### MODELS 49-240, 49-241, 49-243, 49-280, 49-281, 49-480, 49-481

**EXAMPLE: 49 - 240 - O - 60" x 4" - B - AW - C - MM - —**

#### 1a. Models

- 49-240 1/2" (13) spacing, 1/4" (6) bars, 0° deflection
- 49-241 1/2" (13) spacing, 1/4" (6) bars, 15° deflection
- 49-243 1/2" (13) spacing, 1/4" (6) bars, 30° deflection
- 49-280 1/2" (13) spacing, 1/8" (3) bars, 0° deflection
- 49-281 1/2" (13) spacing, 1/8" (3) bars, 15° deflection
- 49-480 1/4" (6) spacing, 1/8" (3) bars, 0° deflection
- 49-481 1/4" (6) spacing, 1/8" (3) bars, 15° deflection

#### Blank-off

- 49-BO Steel – 6 ft. long

#### 1b. Damper

(model suffix)

- None (default)
- O Steel Opposed Blade Damper

#### 2. Nominal Length

inches or mm's

#### 3. Width

inches or mm's

#### 4. Frame/Border Type

- A 1" (25) Flange
- B 3/4" (19) Flange
- C 1" (25) Flange and Sub-frame
- D 1" (25) Flange with Deep Stack
- E 1/2" (13) Flange
- CO Core only

#### Heavy Duty Frame/Border Type

- F 1" (25) Flange, Heavy Duty (Floor)
- G No Flange, Heavy Duty (Floor)
- H 3/4" (19) Beveled Flange, Heavy Duty (Floor)
- K Tape and Spackle

#### 5. Finish

- AW Appliance White (default)
- AL Aluminum
- BK Black
- BW British White
- MI Mill
- PC Prime coat paint
- PPA Paint prepared aluminum
- SP Special custom color
- SA Satin (clear) anodized
- LBA Light Bronze anodized
- MBA Medium Bronze anodized
- DBA Dark Bronze anodized
- BC Brushed and clear coat lacquer
- LBP Light Bronze paint
- MBP Medium Bronze paint
- DBP Dark Bronze paint

#### 6. Fastening

- N None (default)
- A Screw Holes
- B Spring Clips
- C Concealed mounting
- HC1 Hard Ceiling Clip - 5/8" (16) drywall
- HC5 Hard Ceiling Clip - 1/2" (13) drywall

#### 7. End Cap Configuration

(Not applicable on Frame/Border Type CO)

- MM Mitered Mitered (default)
- OO Open Open
- MO Mitered Open (0°)
- MU Mitered Open, Deflection up (15°, 30°)
- MD Mitered Open, Deflection down (15°, 30°)

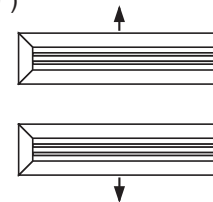

#### OTHER OPTIONS AND ACCESSORIES:

#### 8. Access Door

- AD1L Left Side
- AD1R Right Side
- AD3L Center, opens from Left Side  
Specify 'X' Dimension (in. [mm])
- AD3R Center, opens from Right Side  
Specify 'X' Dimension (in. [mm])

#### 9. Heavy Duty Core

- HC Heavy Duty Core

#### 10. Deflector Vanes

- DV Directional Vanes (D, F, G or H Frame only)

#### 11. Angle Cut

- None (default)
- AC1 One end, Specify Angle
- AC2 Both ends, Specify Angle

#### Notes:

1. Type A fastening is not available on Frame Types E, G or H. Types B and C fastening are not available with Frame Type K. Types HC1 and HC5 fastening are only available with Frame Type K.
2. Access door not available with Frame/Border Types F, G, H or K or when damper is required. AD1L and AD1R require mitered end cap same side.
3. Blank-offs are supplied in 6 ft. sections for field trimming. Specify width only.
4. Angle cut AC1 is not applicable with end cap MM. AC2 requires OO end cap. If AC1 or AC2 is selected with Frame/Border Type CO then end cap will not apply.

## HOW TO ORDER

### MITERED CORNER SECTION LINEAR BAR GRILLES – MODEL SERIES 4900

MODELS 49-240MC, 49-241MC, 49-243MC, 49-280MC, 49-281MC, 49-480MC, 49-481MC

EXAMPLE: 49 - 240MC - 4" - 12 - B - AW - C - FO - 90

**1. Models**

- 49-240MC 1/2" (13) spacing, 1/4" (6) bars, 0° deflection
- 49-241MC 1/2" (13) spacing, 1/4" (6) bars, 15° deflection
- 49-243MC 1/2" (13) spacing, 1/4" (6) bars, 30° deflection
- 49-280MC 1/2" (13) spacing, 1/8" (3) bars, 0° deflection
- 49-281MC 1/2" (13) spacing, 1/8" (3) bars, 15° deflection
- 49-480MC 1/4" (6) spacing, 1/8" (3) bars, 0° deflection
- 49-481MC 1/4" (6) spacing, 1/8" (3) bars, 15° deflection

**2. Width**

inches or mm's

**3. Duct Length - Overall Dimension**

inches or mm's

- 12 12" (305) (Default if width is ≤ 4" [102])
- 18 18" (457) (Default if width is > 4" [102])

**4. Frame/Border Type**

- A 1" (25) Flange
- B 3/4" (19) Flange
- C 1" (25) Flange and Sub-frame
- D 1" (25) Flange with Deep Stack
- E 1/2" (13) Flange

**Heavy Duty Frame/Border Type**

- F 1" (25) Flange, Heavy Duty (Floor)
- G No Flange, Heavy Duty (Floor)
- H 3/4" (19) Beveled Flange, Heavy Duty (Floor)
- K Tape and Spackle

**5. Finish**

- AW Appliance White (default)
- AL Aluminum
- BK Black
- BW British White
- MI Mill
- PC Prime coat paint
- PPA Paint prepared aluminum
- SP Special custom color
- SA Satin (clear) anodized
- LBA Light Bronze anodized
- MBA Medium Bronze anodized
- DBA Dark Bronze anodized
- BC Brushed and clear coat lacquer
- LBP Light Bronze paint
- MBP Medium Bronze paint
- DBP Dark Bronze paint

**6. Fastening**

- N None
- A Screw Holes
- B Spring Clips
- C Concealed mounting
- HC1 Hard Ceiling Clip - 5/8" (16) drywall
- HC5 Hard Ceiling Clip - 1/2" (13) drywall

**7. Application/Pattern**

**0° Deflection Cores:**

- FO Floor, Ceiling, Sill (Flat)
- WC Sidewall, Inside
- WD Sidewall, Outside

**15° and 30° Deflection Cores:**

- FA Floor, Ceiling, Sill; Deflection Inside
- FB Floor, Ceiling, Sill; Deflection Outside
- WC Sidewall, Inside
- WD Sidewall, Outside

**8. Mitered Angle**

- 90 90° (default)
- 135 135°
- AN Degree of Angle (Specify angle = \_\_\_\_ )

**Notes:**

1. Damper not available.
2. Type A fastening is not available on Frame Types E, G or H. Types B and C fastening are not available with Frame Type K. Types HC1 and HC5 fastening are only available with Frame Type K.

## HOW TO SPECIFY

### LINEAR BAR GRILLES – MODEL SERIES 4900

**MODELS 49-240, 49-241, 49-243, 49-280, 49-281, 49-480, 49-481**

#### SUGGESTED SPECIFICATION:

Furnish and install **Nailor Model** (select one) **49-240** (1/2" [13] spacing, 1/4" [6] bars, 0° deflection); **49-241** (1/2" [13] spacing, 1/4" [6] bars, 15° deflection); **49-243** (1/2" [13] spacing, 1/4" [6] bars, 30° deflection); **49-280** (1/2" [13] spacing, 1/8" [3] bars, 0° deflection); **49-281** (1/2" [13] spacing, 1/8" [3] bars, 15° deflection); **49-480** (1/4" [6] spacing, 1/8" [3] bars, 0° deflection); **49-481** (1/4" [6] spacing, 1/8" [3] bars, 15° deflection) **Linear Bar Grilles** of the sizes and capacities shown on the plans and air distribution schedules. The maximum length of a single section shall be 72" (1829) long. All sizes larger than 72" (1829) shall be provided in continuous multiple sections. Alignment strips are to be provided for joining continuous grille sections together. All frame types shall be extruded aluminum and include fastening as specified. A grille with a frame selection of A, B, C, D or E shall have a non-removable core that has fixed extruded aluminum bars and extruded aluminum cross bars that are spaced on a maximum of 12" (305) centers. A grille with a heavy duty frame selection of F, G, H or K shall have a removable core that attaches with core clips. The core shall have fixed extruded aluminum bars and extruded aluminum cross bars that are spaced on a maximum of 8" (203) centers. The finish is to be AW Appliance White (optional finishes are available).

(Optional) A damper, constructed of heavy gauge corrosion-resistant steel and operable from the face of the grille, shall be provided on all units.

The manufacturer shall provide published performance data for the linear bar grille, which shall be tested in accordance with ANSI/ASHRAE Standard 70–2006.