

**MODEL 1612QS
FORMED ALUMINUM (OR STEEL) LOUVERS
ACOUSTICAL, SIGHTPROOF**

Nailor Model 1612QS Acoustical Louver combines effective sound attenuation and good airflow performance with protection from the elements in an architecturally pleasing design. Acoustical blade insulation provides outstanding sound absorption qualities and the closely centered multiple formed J blade design is sight-proof, providing additional protection from vandalism in ground level applications. Available in channel or flanged type, the 12" (305) deep frame installs easily in most common wall configurations. Suitable for either intake or exhaust applications. Nailor Model 1612QS is AMCA Licensed for Water Penetration, Sound and Air Performance.



Model 1612QS



Models 1704J and 1706J

**MODELS 1704J & 1706J
FORMED STEEL LOUVERS
ARCHITECTURAL BLADE**

Nailor Models 1704J and 1706J are architecturally styled louvers utilizing J style blades, designed with smooth, clean lines that visually compliment any structure's exterior styling. Galvanized steel construction is economical, durable and can withstand the most demanding conditions. The blade design features a rear water baffle and provides good protection against general weather conditions, with low pressure drop characteristics and a high free area. Suitable for use in ventilation, exhaust and low to medium velocity intake applications. Available in channel or flanged type, the 4" (102) or 6" (152) deep frame installs easily in most common wall configurations.

**MODELS 1704JD & 1706JD
FORMED STEEL LOUVERS
DRAINABLE HEAD, DRAINABLE BLADE**

Nailor Models 1704JD and 1706JD are architecturally styled louvers combining J style blades with a drainable head feature that utilizes a top rain gutter to collect cascading water and channel it out through concealed downspouts in the side frame, preventing it from entering into the building. Durable galvanized steel construction, good weather protection and great air performance result in an outstanding functional louver at an affordable cost. Suitable for use in ventilation, exhaust and low to medium velocity intake applications where water penetration is a concern. Available in channel or flanged type, the 4" (102) or 6" (152) deep frame installs easily in most common wall configurations.



Models 1704JD and 1706JD

APPLICATIONS AND SIZING GUIDE

Selection of a louver for a specific application is determined by many variables including: aesthetic requirements, wall type/depth, pressure loss criteria and water penetration criteria. After determining the relative importance of each variable, a louver style and model can be selected by comparing individual design details and performance data, all included within this catalog. Use the following Applications Guide to assist in determining the appropriate louver type for your application:

Louver Application	Louver Type	Model
EXTRUDED ALUMINUM - 1600 Series Louvers by Application		
Decorative, A/C units, Curtain wall, Ventilation, Exhaust, Low to medium velocity intake	Thinline Frame Louver	1602J, 1602K
Decorative, Specialty Shapes, Ventilation, Exhaust, Low to medium velocity intake	Architectural Blade Louver	1604J, 1606J
Light to moderate rain, Ventilation, Exhaust, Low to medium velocity intake	Drainable Head, Architectural J Blade Louver	1604JD, 1606JD
Light to moderate rain w/ light wind, Exhaust, Low to medium velocity intake	Drainable Head, K Blade Louver	1604KD, 1606KD
Light to moderate rain, Exhaust, Low to medium velocity intake, Low pressure loss	Drainable Blade Louver	1602D, 1604D, 1606D
Moderate to heavy rain, Exhaust, Medium to high velocity intake, Low pressure loss	Dual Drainable Blade Louver	1604DD, 1606DD
Moderate to high winds w/ moderate to heavy rain, Exhaust, Higher velocity intake	Wind Driven Rain Louver	1605WD
Air Control & Shut-off, Light to moderate rain, Exhaust, Low to medium velocity intake	Combination & Adjustable, Drainable Blade Louver	1606CDAF, 1604AD, 1606AD
Sound control, Ventilation, Exhaust, Low to medium velocity intake	Acoustical Louver	1612QS
Visual screen, Vandalism concerns, Ventilation, Exhaust, Low to medium velocity intake	Sightproof Louver	1604Y
Foundation, Crawl space & utility area ventilation, Exhaust, Low to medium velocity intake	Brick Vent	16BVC, 16BVE, 16BVF
FORMED STEEL - 1700 Series Louvers by Application		
Decorative, General weather conditions, Ventilation, Exhaust, Low to medium velocity intake	Architectural Blade Louver	1704J, 1706J
Decorative, Light to moderate rain, Exhaust, Low to medium velocity intake	Drainable Head, Architectural Blade Louver	1704JD, 1706JD
Light to moderate rain, Exhaust, Low to medium velocity intake	Drainable Blade Louver	1704D, 1706D
Light to moderate rain, Exhaust, High velocity intake	Drainable Blade High Performance Louver	1704DHP, 1706DHP
Air Control, Ventilation, Exhaust, Intake	Adjustable, Drainable Blade Louver	1704AD, 1706AD

HOW TO SIZE LOUVERS

The prime factor involved in sizing a louver is the velocity of the air through its free area. The free area is the actual unobstructed area of a louver through which air can travel. Other factors such as pressure drop and amount of water penetration are dependent upon the free area velocity and can be determined by using the respective performance charts provided for each specific louver model.

1. Select Model:

Choose the louver model that is the best suited for the specific application. Use the Applications Guide and 'Quick-Select' Model Guide to assist in making a selection, if so desired.

2. Select Free area Velocity:

Select optimum free area velocity for the specific application, checking Pressure Drop and Water Penetration charts for acceptable performance. For 'exhaust only' applications, water penetration data generally does not need to be considered. For extra weather protection, select a free air velocity that is below the beginning point of water penetration.

As a rule of thumb, ASHRAE suggests 400 fpm (122 m/min.) for intake applications and 500 fpm (152 m/min.) for exhaust applications.

3. Determine Required Louver Free Area:

Divide given AIRFLOW (cfm) by the selected FREE AREA VELOCITY (fpm) to determine the required louver free area. Using the Free Area Chart for the specific louver model chosen, select a louver size that provides the required Free Area. If, in the application, the louver size is given, the maximum practical airflow can be determined by working backwards from the free area chart.

SIZING EXAMPLES:

Example A:
AIRFLOW GIVEN: DETERMINE LOUVER SIZE

- Determine required louver free area by dividing AIRFLOW by acceptable FREE AREA VELOCITY. (Use performance charts to assist in selecting Free Area Velocity):
 $\text{_____ cfm} \div \text{_____ fpm} = \text{_____ sq. ft. Free Area.}$
- Using the Free Area Chart for chosen model; select a louver size with at least the required free area:
 $\text{_____ wide} \times \text{_____ high} = \text{_____ sq. ft. Free Area.}$

Example B:
LOUVER SIZE GIVEN: DETERMINE MAXIMUM AIRFLOW

- Given louver size: _____ W x _____ H. Use the Free Area Chart for chosen model to determine the area.
- Multiply FREE AREA x acceptable FREE AREA VELOCITY to determine maximum airflow:
 $\text{_____ sq. ft.} \times \text{_____ fpm} = \text{_____ cfm maximum airflow.}$
- Using the Pressure Drop Chart for chosen model; check the pressure drop at the determined airflow rate and resulting free area velocity.

Note: To minimize water penetration when sizing intake louvers, select a Free Area Velocity that is below the point of beginning water penetration.

'QUICK-SELECT' MODEL GUIDE

Model	Depth	Blade Style/Angle	Free Area Sq. Ft. (Sq. Meters)	Free Area %	Beginning Point of Water Penetration
Extruded Aluminum • Stationary • Non-Drainable • Thinline Frame					
1602J	2" (51)	J/30°	7.14 (0.66)	45%	549 fpm (167 m/min.)
1602K	2" (51)	K/30°	7.55 (0.70)	47%	401 fpm (122 m/min.)
Extruded Aluminum • Stationary • Architectural Blade					
1604J	4" (102)	J/37°	8.62 (0.80)	54%	722 fpm (220 m/min.)
1606J	6" (152)	J/37°	8.13 (0.76)	51%	1029 fpm (314 m/min.)
Extruded Aluminum • Stationary • Drainable Head					
1604JD	4" (102)	J/37°	8.57 (0.80)	54%	961 fpm (293 m/min.)
1606JD	6" (152)	J/37°	7.45 (0.69)	47%	1250 fpm (381 m/min.)
1604KD	4" (102)	K/37°	7.51 (0.70)	47%	892 fpm (272 m/min.)
1606KD	6" (152)	K/37°	7.93 (0.74)	50%	1017 fpm (310 m/min.)
Extruded Aluminum • Stationary • Drainable Head & Drainable Blade					
1602D	2" (51)	Drainable/45°	6.91 (0.64)	43%	1123 fpm (342 m/min.)
1604D	4" (102)	Drainable/37°	8.26 (0.77)	52%	906 fpm (272 m/min.)
1606D	6" (152)	Drainable/37°/45°	7.99 (0.74)	50%	1195 fpm (364 m/min.)
1604DD	4" (102)	Dual Drainable/37°	8.14 (0.76)	51%	1000 fpm (305 m/min.)
1606DD	6" (152)	Dual Drainable/37°	7.92 (0.74)	50%	1193 fpm (364 m/min.)
Extruded Aluminum • Stationary • Wind-Driven Rain Resistant					
1605WD	5" (127)	Drainable/30°	8.64 (0.80)	54%	1025 fpm (313 m/min.)
Extruded Aluminum • Adjustable • Drainable Blade					
1604AD	4" (102)	Adjustable, Drainable/37 1/2°	7.10 (0.66)	44%	953 fpm (290 m/min.)
1606AD	6" (152)	Adjustable, Drainable/37 1/2°	8.15 (0.76)	51%	970 fpm (296 m/min.)
Extruded Aluminum • Combination Louver/Damper • Drainable Blade					
1606CDAF	6" (152)	Airfoil, Drainable/45°	6.89 (0.64)	43%	1142 fpm (348 m/min.)
Extruded Aluminum • Stationary • Sightproof					
1604Y	4" (102)	Inverted Y/45°	4.67 (0.43)	29%	—
Formed Aluminum (or Steel) • Acoustical					
1612QS	12" (305)	Insulated, J Sightproof/45°	4.72 (0.44)	30%	826 fpm (252 m/min.)
Formed Steel • Stationary • Architectural Blade					
1704J	4" (102)	J/45°	8.53 (0.79)	53%	869 fpm (265 m/min.)
1706J	6" (152)	J/45°	8.53 (0.79)	53%	938 fpm (286 m/min.)
Formed Steel • Stationary • Drainable Head					
1704JD	4" (102)	J/45°	8.38 (0.78)	52%	1123 fpm (342 m/min.)
1706JD	6" (152)	J/45°	7.85 (0.73)	49%	1250 fpm (381 m/min.)
Formed Steel • Stationary • Drainable Blade					
1704D	4" (102)	Drainable/45°	8.44 (0.78)	53%	976 fpm (298 m/min.)
1706D	6" (152)	Drainable/45°	8.02 (0.75)	50%	1250 fpm (381 m/min.)
1704DHP	4" (102)	Drainable/37 1/2°	8.55 (0.79)	53%	896 fpm (273 m/min.)
1706DHP	6" (152)	Drainable/37 1/2°	9.05 (0.84)	56%	988 fpm (301 m/min.)
Formed Steel • Adjustable • Drainable Blade					
1704AD	4" (102)	Adjustable, Drainable/37 1/2°	8.03 (0.75)	50%	991 fpm (302 m/min.)
1706AD	6" (152)	Adjustable, Drainable/37 1/2°	8.80 (0.82)	55%	977 fpm (298 m/min.)

- Dimensions are in inches (mm).
- Free Area shown are for 48" x 48" (1219 x 1219).
- Beginning point of Water Penetration: 0.01 oz./sq. ft. (3 ml/sq. m), 15 minute test duration.

- AMCA LICENSED
- SOUND CONTROL
- SIGHTPROOF DESIGN
- CORROSION RESISTANT
- HIGH PERFORMANCE

Model:
1612QS 12" (305) Deep



Model 1612QS

Model 1612QS

Model 1612QS Acoustical Louvers combine effective sound attenuation and good airflow performance with protection from the elements in an architecturally pleasing design. Acoustical insulation provides outstanding sound absorption qualities and the closely centered multiple formed J blade design is sight-proof, providing additional benefits as a visual screen and safety barrier in ground level applications where vandalism is a concern. Suitable for either intake or exhaust applications where maximum noise reduction is required. Available in channel or flanged type, the 12" (305) deep frame installs easily in most common wall configurations. Model 1612QS is AMCA Licensed for Water Penetration, Sound and Air Performance.

STANDARD CONSTRUCTION:

- Frame:** 12" (305) deep. Formed aluminum, .080" (2.03) nominal thickness.
- Blades:** Formed aluminum, .080" (2.03) nominal thickness. Perforated interior retains and protects internal insulation.
- Acoustical Insulation:** Fiberglass.
- Blade Angle:** Fixed at 45 degrees.
- Blade Spacing:** Approximately 6 1/2" (165) on centers.
- Mullions:** Visible type, as required, depending upon width.
- Screen:** 3/4" x .051" (19 x 1.3) expanded, flattened aluminum bird screen in removable frame (adds approximately 3/8" [10] to louver depth).
- Finish:** Mill.
- Minimum Size:** 12" W x 18" H (305 x 457).
- Maximum Single Section Size:** 60" W x 96" H (1524 x 3048).
- Section Size:** Larger louvers will require field assembly of smaller sections.

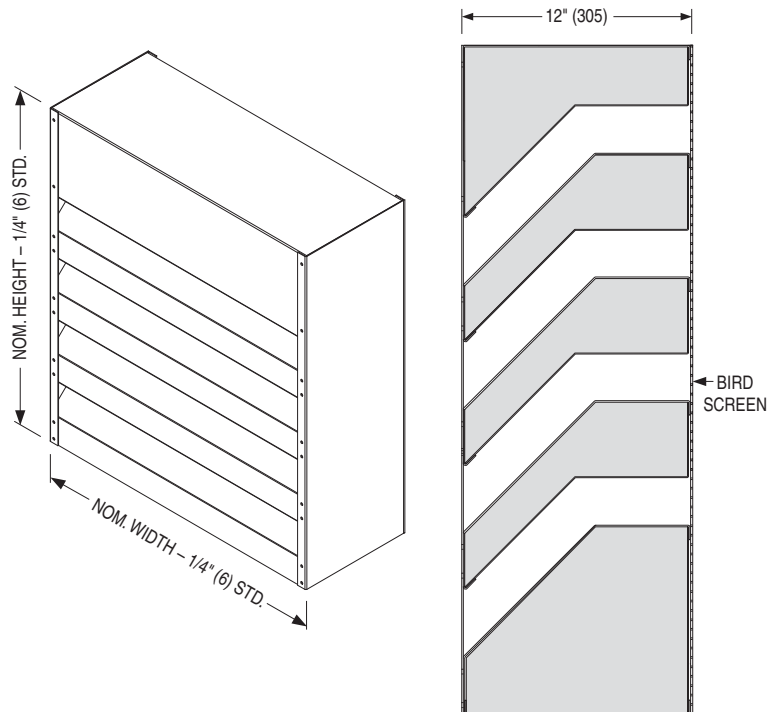

MODEL 1612QS

COMMON OPTIONS:

- Flanged Frame.
- Aluminum or Type 304 Stainless Steel Insect Screens.
- Extended Sills.
- Variety of Standard and High Performance Powder Coat finishes available in a multitude of colors. Custom color matching available.
- Clear or Color Anodized finishes. (Aluminum construction only).



PERFORMANCE DATA:

MODEL: 1612QS

FREE AREA in Square Feet and Square Meters

		Width in Inches and Meters								
		12	18	24	30	36	42	48	54	60
Height in Inches and Meters	18	0.30	0.46	0.61	0.76	0.91	1.07	1.22	1.37	1.52
	0.46	0.27	0.44	0.61	0.77	0.94	1.11	1.27	1.44	1.61
	0.61	0.03	0.04	0.06	0.07	0.09	0.10	0.12	0.13	0.15
	24	0.41	0.66	0.92	1.17	1.42	1.68	1.93	2.18	2.44
	0.61	0.04	0.06	0.09	0.11	0.13	0.16	0.18	0.20	0.23
	30	0.56	0.91	1.26	1.60	1.95	2.30	2.64	2.99	3.34
	0.76	0.05	0.08	0.12	0.15	0.18	0.21	0.25	0.28	0.31
	36	0.71	1.14	1.58	2.01	2.45	2.88	3.32	3.75	4.19
	0.91	0.07	0.11	0.15	0.19	0.23	0.27	0.31	0.35	0.39
	42	0.85	1.37	1.90	2.42	2.94	3.47	3.99	4.51	5.04
	1.07	0.08	0.13	0.18	0.22	0.27	0.32	0.37	0.42	0.47
	48	0.99	1.61	2.22	2.83	3.44	4.05	4.72	5.28	5.89
	1.22	0.09	0.15	0.21	0.26	0.32	0.38	0.44	0.49	0.55
	54	1.14	1.84	2.54	3.24	3.94	4.64	5.34	6.04	6.74
1.37	0.11	0.17	0.24	0.30	0.37	0.43	0.50	0.56	0.63	
60	1.28	2.07	2.86	3.65	4.44	5.23	6.02	6.81	7.59	
1.52	0.12	0.19	0.27	0.34	0.41	0.49	0.56	0.63	0.71	
66	1.43	2.30	3.18	4.06	4.94	5.81	6.69	7.57	8.45	
1.68	0.13	0.21	0.30	0.38	0.46	0.54	0.62	0.70	0.78	
72	1.57	2.54	3.50	4.47	5.43	6.40	7.36	8.33	9.30	
1.83	0.15	0.24	0.33	0.41	0.50	0.59	0.68	0.77	0.86	
78	1.71	2.77	3.82	4.88	5.93	6.98	8.04	9.09	10.15	
1.98	0.16	0.26	0.36	0.45	0.55	0.65	0.75	0.84	0.94	
84	1.86	3.00	4.14	5.28	6.43	7.57	8.71	9.85	11.00	
2.13	0.17	0.28	0.38	0.49	0.60	0.70	0.81	0.92	1.02	
90	2.14	3.46	4.78	6.10	7.42	8.74	10.06	11.38	12.70	
2.29	0.20	0.32	0.44	0.57	0.69	0.81	0.93	1.06	1.18	
96	2.29	3.70	5.10	6.51	7.92	9.33	10.73	12.14	13.55	
2.44	0.21	0.34	0.47	0.60	0.74	0.87	1.00	1.13	1.26	



Nailor Industries Inc. certifies the Model 1612QS shown herein is licensed to bear the AMCA Seal. The ratings shown are based on tests and procedures performed in accordance with AMCA Publication 511 and comply with the requirements of the AMCA Certified Ratings Program. The AMCA Certified Ratings Seal applies to Water Penetration, Air Performance and Sound ratings.

AIRFLOW/WATER PENETRATION DATA

for 48" x 48" (1219 x 1219) Louver Size

Model		1612QS
Free Area %		30%
Free Area sq. ft. (sq. m.)		4.72 (0.44)
INTAKE	Free Area Velocity at Point of Beginning Water Penetration at .01 oz./sq. ft. (3 ml/sq. m) (15 min. test duration)	826 fpm (252 m/min.)
	Air Volume at Free Area Velocity shown	3899 cfm (1840 l/s)
	Pressure Drop at Free Area Velocity shown	.10 in. w.g. (25 Pa)

NOTE: To minimize water penetration when sizing intake louvers, select a Free Area Velocity that is **below** the point of beginning water penetration.

FREE FIELD NOISE REDUCTION

Octave Band (Frequency) (Hz)	Free Field Noise Reduction (db)	Transmission Loss (db)	Sound Transmission Class
2 (125)	11	5	13
3 (250)	11	5	
4 (500)	16	10	
5 (1000)	25	19	
6 (2000)	20	14	
7 (4000)	19	13	

NOTE: The Sound Transmission Class (STC) is a single number rating of the louver's resistance to transfer airborne sound, calculated in accordance with ASTM E413-04. The higher the STC rating number, the less sound is transmitted through the louver. STC is not AMCA certified.

PRESSURE DROP

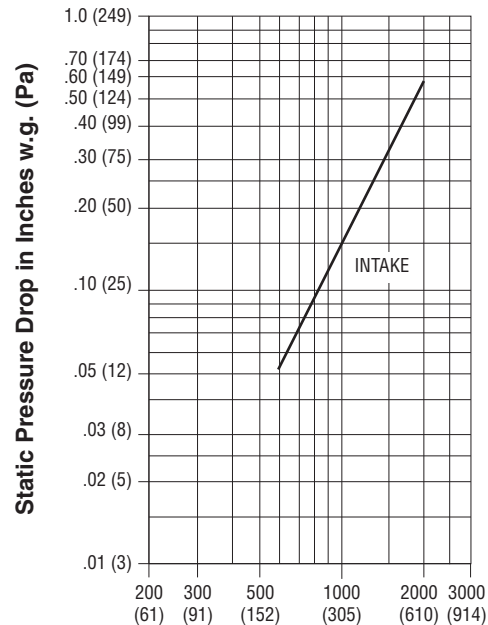

Air Velocity in Feet (Meters) Per Minute Through Free Area

Louver test size: 48" x 48" (1219 x 1219 mm).

Standard air density @ 0.075 lbs/ft³.

Tested to AMCA Fig. 5.5 – 6.5.

HOW TO SPECIFY OR TO ORDER

A
LOUVERS

MODEL 1612QS
FORMED ALUMINUM (OR STEEL) ACOUSTICAL LOUVERS

SUGGESTED SPECIFICATION:

Provide and install, as shown on plans and/or schedules, formed aluminum louvers meeting or exceeding the following criteria: Frame shall be 12" (305) deep channel type (**or specifier to select:** flanged type), 1/4" (6.3) undersize (**or specifier to select:** exact size **or** 3/8" [9.5] undersize **or** 1/2" [12.7] undersize), with integral caulking slots (and **specifier to select, if required:** extended sill), constructed from formed aluminum of .080" (2.03) nominal wall thickness. Blades shall be sightproof J style, constructed from formed aluminum of .080" (2.03) nominal wall thickness with perforated interior and internal mineral wool insulation, fixed at 45 degrees on approximately 6 1/2" (165) centers. Factory assembled louver components to be mechanically fastened (**or specifier to select:** welded construction). Large louvers that require multiple sections for shipping and field assembly shall be constructed with visible type Mullions when installed together on site. Louvers shall be equipped with removable 3/4" x .051 (19 x 1.3) expanded, flattened aluminum bird screen (**or specifier to select:** type 304 stainless steel bird screen **and/or** aluminum insect screen **and/or** type 304 stainless steel insect screen **or** no screen).

Finish shall be standard mill (**or specifier to select:** prime coat **or** 204-R1 clear anodized to a min. depth of 0.4 mil, with 1 year warranty **or** 215-R1 clear anodized to a min. depth of 0.7 mil, with 5 year warranty **or** color anodized; color to be selected from standard Nailor anodizing colors **or** AAMA 2603 thermosetting polyester powder coat, with 1 year warranty; color to be (**specifier to select:** selected from Nailor standard color chart **or** custom color) **or** AAMA 2604 high performance polyester powder coat, with 5 year warranty; color to be (**specifier to select:** selected from Nailor standard color chart **or** custom color) **or** AAMA 2605 FEVE fluoropolymer powder coat, with 10 year warranty; color to be (**specifier to select:** selected from Nailor standard color chart **or** custom color) **or** Kynar 500/Hylar 5000 70% PVDF coating, with 5 year warranty; color to be (**specifier to select:** selected from Nailor standard color chart **or** custom color) **or** Kynar 500/Hylar 5000 50% PVDF coating, with 10 year warranty; color to be (**specifier to select:** selected from Nailor standard color chart **or** custom color).

Performance data must be licensed by AMCA under the AMCA 511 Certified Ratings Program and shall bear the AMCA Certified Ratings seal for water penetration, sound and air performance. Free area, water penetration, free field noise reduction and pressure drop data submitted shall be equal to or better than specified model. Standard of acceptance: Nailor Industries, Inc. Model 1612QS.

MODEL: 1612QS
FORMED ALUMINUM (OR STEEL) ACOUSTICAL LOUVERS

EXAMPLE: 1612QS - 48x36 - U25 - CH - BSA - MI

- 1. **Models**
1612QS 12" (305) Deep, Sightproof
- 2. **Nominal Width x Height**
inches (mm's)
- 3. **Construction**
ALM Aluminum (default)
18GA 18 ga. galvanized steel
- 4. **Sizing**
U00 Exact Size
U25 Undersize 1/4" (6.3) (default)
U38 Undersize 3/8" (9.5)
U50 Undersize 1/2" (12.7)
- 5. **Frame**
CH Channel (default)
FL Flanged
- 6. **Bird Screen**
BSA Aluminum (default)
BSG Galvanized Steel
BSSS Type 304 Stainless Steel
BSN None (default)
- 7. **Insect Screen**
- None (default)
ISA Aluminum
ISSS Type 304 Stainless Steel
- 8. **Finish**
MI Mill Finish (default)
PC3S Powder Coat, Standard Color
PC3C Powder Coat, Custom Color
PC4S H. P. Powder Coat, Standard Color
PC4C H. P. Powder Coat, Custom Color

- PC5S Fluoropolymer Powder Coat, Standard Color
- PC5C Fluoropolymer Powder Coat, Custom Color
- PPC Prime Coat
- AN04 Anodized, Clear 204-R1
- AN15 Anodized, Clear 215-R1
- ANLB Anodized, Light Bronze
- ANMB Anodized, Medium Bronze
- ANDB Anodized, Dark Bronze
- ANBK Anodized, Black

OPTIONS & ACCESSORIES:

- 10. **Welded Construction**
- None (default)
WE Welded Construction
- 11. **Extended Sill**
- None (default)
ESI Extended Sill
- 12. **Filter Rack**
- None (default)
FR1 1" (25) Filter rack
FR2 2" (51) Filter rack
- 13a. **Sleeve**
- None (default)
SGLV Galvanized Steel
SALU Aluminum
S304 Type 304 Stainless Steel

- 13b. **Sleeve Length**
SL = Specify
12" (305) standard (default)
8" – 28" (203 – 711)
- 13c. **Sleeve Gauge**
- None (default)
20G 20 Ga.
18G 18 Ga.
16G 16 Ga.
14G 14 Ga.
10G 10 Ga.

Notes:

1. Standard color powder coat paint finishes require a color selection from the 21 color finishes on the "Nailor Louver Finishes and Color Guide".

Codes: LF00 Color to follow, LF01 Slate Blue, LF02 Medium Bronze, LF03 Sandstone, LF04 Light Gray, LF05 Charcoal, LF06 Bone White, LF07 Western Tan, LF08 Architectural Bronze, LF09 Regal Blue, LF10 Forest Green, LF11 Surrey Beige, LF12 Royal Brown, LF13 Barn Red, LF14 Burgandy, LF15 Clay, LF16 Almond, LF17 Coastal White, LF18 Vista Green, LF19 Black, LF20 Gloss Black, LF21 Campus Green.

2. Custom color powder coat paint finishes require color matching. A suitable paint chip must be supplied and Nailor will select or mix and formulate a powder coat paint that matches as closely as possible. We will forward a sample for approval.

Codes: LF00 Color to follow. You may alternatively enter a unique code and description.

Options and Accessories

Nailor extruded aluminum and formed steel louvers are available with a variety of options and accessories to suit design specific applications. Selecting the proper accessories and options can save time and labor as well as enhance the visual aesthetics of a louver. Contact your Nailor representative for more information on Nailor custom louver manufacturing capabilities and additional features for your job specific requirements.

FRAME OPTIONS:

OPTION CODE **CH**
STANDARD CHANNEL FRAME

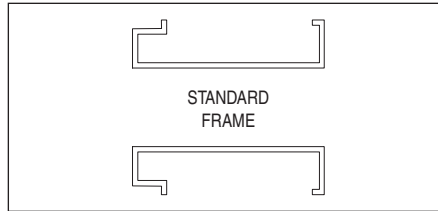

OPTION CODE **FL**
FLANGED FRAME

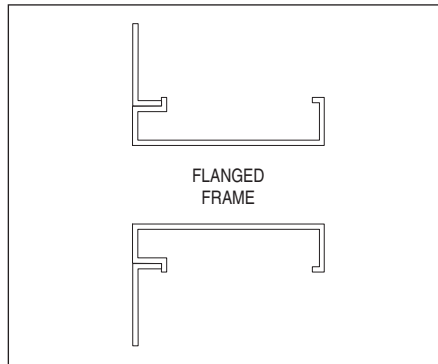

OPTION CODE **GA**
GLAZING ADAPTOR (SIDE VIEW)

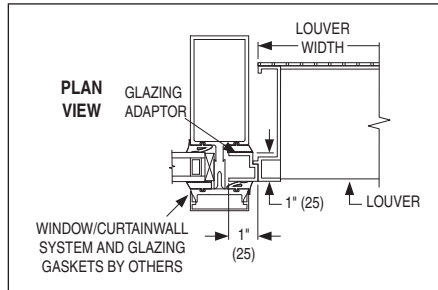

All Nailor extruded aluminum and formed steel louver models come standard with channel type frames and are available with an optional flanged frame. Nailor 2", 4", 5" and 6" (51, 102, 127 and 152) deep extruded aluminum louvers are also available with an optional glazing adaptor frame for easy installation into windows or curtain wall systems. When ordered, the flanged and glazing adaptor type frames are factory mounted using mechanical fasteners.

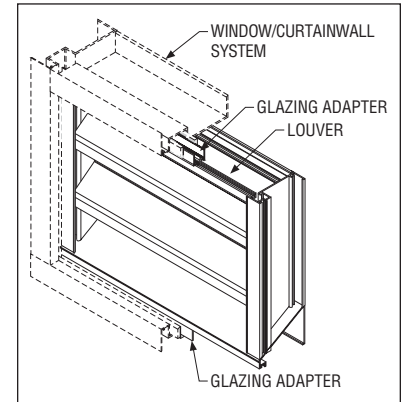

EXTENDED SILL:

OPTION CODE **ESI**
EXTENDED SILL

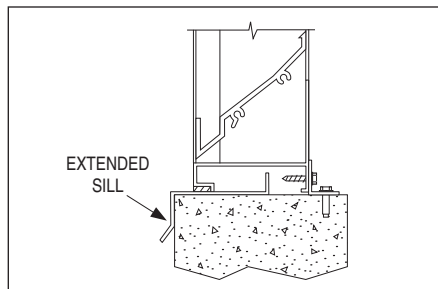

Sill extensions are available on all Nailor extruded aluminum and formed steel louver models and can provide additional deflection of water from the louver opening. An extended sill option may also provide a transition between the louver and adjacent structures. The material and finish of the sill extension will match the frame and blades of the louver. When ordered, sill extensions are shipped loose for field installation.

Note: All louver options are available at an additional cost.

Options and Accessories

MULLION TYPES:

ARCHITECTURAL CONCEALED MULLION DETAIL

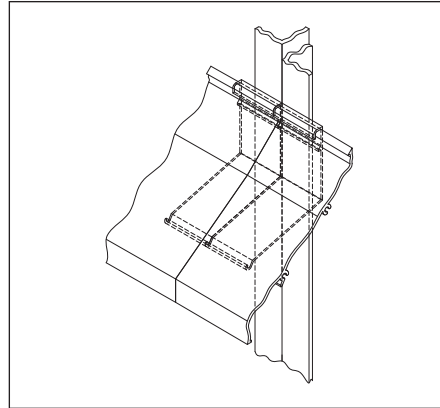

VISIBLE MULLION DETAIL

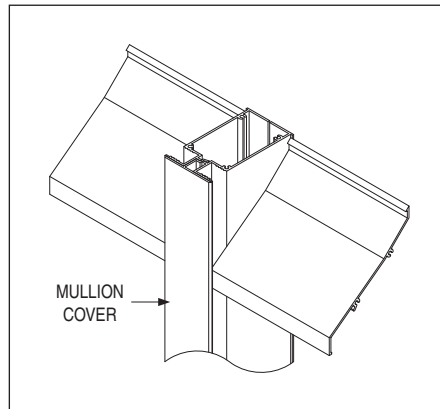

Architectural Concealed Mullions are available on all Nailor stationary non-drainable aluminum louvers, providing a continuous blade appearance without size limitations. Mullions are constructed of the same material as the louver.

Nailor stationary and adjustable/combination drainable blade louvers feature concealed mullions up to 120" (3048) wide, with larger assemblies requiring separate visible frames with downspouts. Visible Mullions are provided with a Mullion Cover to enhance the architectural appearance of the louver. Mullions are constructed of the same material as the louver and finished to match.

FALSE MULLIONS

False mullions, an architectural feature simulating a mullion, are also available where required visually. They may be shipped loose for mounting to the louver at the installation site, or can be an integral extension of the louver frame, factory mounted. Mullions are constructed of the same material as the louver and finished to match.

SCREEN TYPES:

OPTION CODE **BSG**
 BIRD SCREEN - GALV. STEEL (D)
 OPTION CODE **BSA**
 BIRD SCREEN - ALUMINUM
 OPTION CODE **BSSS**
 BIRD SCREEN - TYPE 304 STAINLESS STEEL
 OPTION CODE **BSN**
 BIRD SCREEN - NONE
 OPTION CODE **00**
 INSECT SCREEN - NONE (DEFAULT)
 OPTION CODE **ISA**
 INSECT SCREEN - ALUMINUM
 OPTION CODE **ISSS**
 BIRD SCREEN - TYPE 304 STAINLESS STEEL

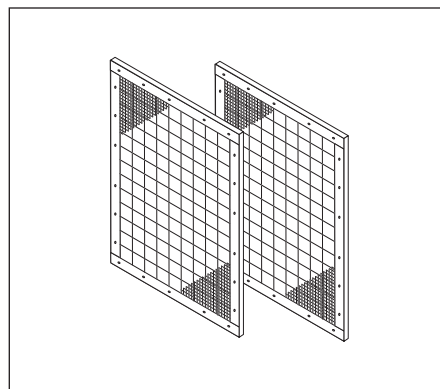

Bird and Insect screens prevent the passage of undesirable elements through the louver while maintaining maximum airflow. All Nailor louvers come standard with a bird screen, either 3/4" x .051 (19 x 1.3) wire expanded and flattened aluminum or 1/2" mesh x 19 ga. (13 x 1.1) wire galvanized, dependent on louver construction, unless ordered otherwise. A variety of screen options are available to suit most applications: 1/2" mesh x 18 ga. (13 x 1.3) wire Type 304 stainless steel bird screens, 18 - 16 mesh, .011 (.30) wire aluminum insect screens and 18 - 16 mesh 0.11" (.30) wire Type 304 stainless steel insect screens may be ordered for all louver types.

Options and Accessories

WELDED CONSTRUCTION:

OPTION CODE **WE**

All Nailor louvers are mechanically fastened to provide a clean visual appearance when painted or anodized. Optional welded construction is available on all Nailor stationary louvers for applications that may be subject to vibration damage, i.e. when located in proximity to an air handler. Welded construction is not available when anodized finish is ordered.

FILTER RACK:

OPTION CODE **FR1**
1" (25) FILTER RACK

OPTION CODE **FR2**
2" (51) FILTER RACK

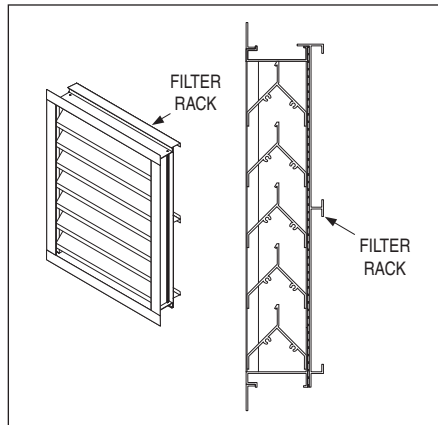

For applications where air filtration is required, Nailor offers 1" (25) or 2" (51) filter racks for standard filters, filters by others. Filters are easily accessible with a slide and lock in style design for quick service. Filter racks are constructed of the same material as the louver and factory installed with mechanical fasteners. All Nailor louvers are available with optional filter racks. Consult your Nailor representative for specific details and dimensional drawings for specific louver applications.

CHANNEL SUB-FRAME AND HINGES:

OPTION CODE **CSUB**
CHANNEL SUB-FRAME

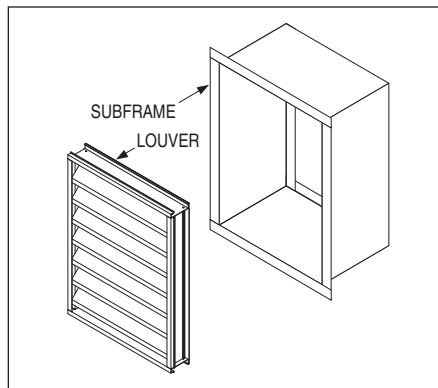

Sub-frames are used as an auxiliary frame around a louver and by adding additional hardware you can enable a louver to be removable, hinged, latched, and for certain applications, restrained. All Nailor extruded aluminum stationary louvers are available with optional channel sub-frames; contact your Nailor representative for sub-frame requirements for steel stationary louvers.

OPTION CODE **HB**
HINGED BOTTOM
OPTION CODE **HL**
HINGED LEFT
OPTION CODE **HR**
HINGED RIGHT
OPTION CODE **HT**
HINGED TOP

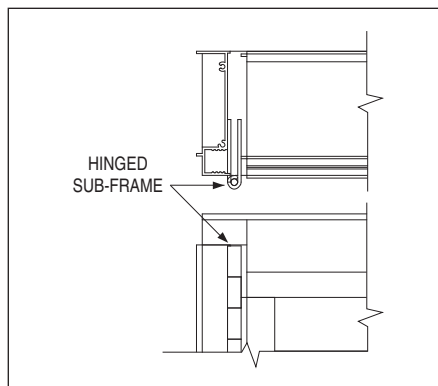

Some applications require access behind a louver for service and maintenance of other system components. When ordered with a channel sub-frame, hinges allow a louver to become an access door, providing easy access behind the louver. Hinges are available on top, bottom, and left or right orientations. Standard piano style hinges are factory mounted when ordered. All Nailor extruded aluminum stationary louvers are available with optional hinges; contact your Nailor representative for hinge requirements for steel stationary louvers.

Options and Accessories

CORNER CONSTRUCTION:

OPTION CODE **SBCC**
BOX CORNER DETAIL

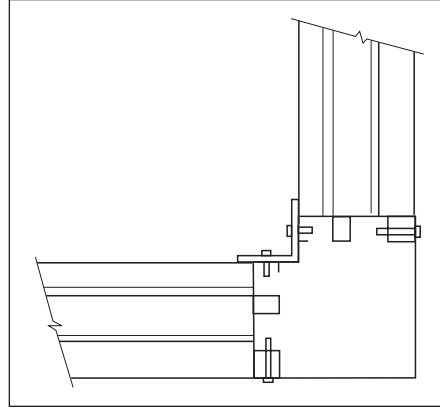

Louvers that follow the architectural line of a building's exterior around a corner may have either mitered or boxed corners, depending on the blade style of the louver selected. All Nailor extruded aluminum stationary J and K non-drainable louvers are available with optional mitered corners providing a desirable continuous look, and all Nailor extruded aluminum stationary drainable louvers are available with optional box corners for corner requirements for steel stationary louvers.

OPTION CODE **SMCC**
MITERED CORNER DETAIL

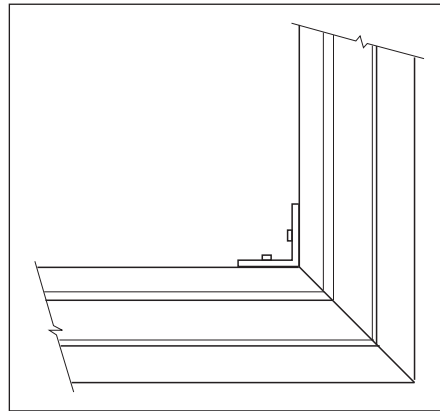

INSTALLATION ANGLES:

OPTION CODE **PACA**
MOUNTING CLIPS

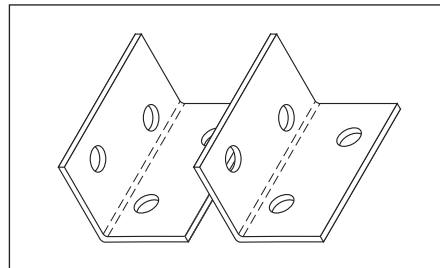

Mounting clips and continuous angles are utilized to anchor a louver to an opening and provide a clean, easy, and speedy installation. When ordered, mounting clips and continuous angles are shipped loose for field assembly. All Nailor extruded aluminum stationary louvers are available with optional mounting clips and continuous angles; contact your Nailor representative for installation angle and mounting clip requirements for steel stationary louvers.

OPTION CODE **PAAA**
CONTINUOUS ANGLES

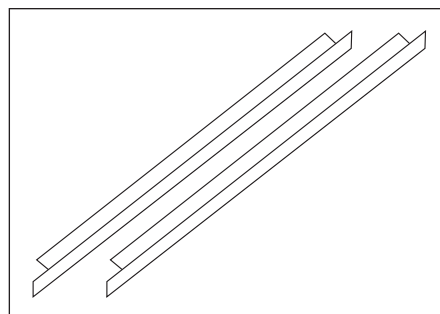

Options and Accessories

BLANK-OFF PANELS:

OPTION CODE BA

.040" ALUMINUM

OPTION CODE BAI1

.040" ALUMINUM W/1" (25) INSUL.

OPTION CODE BAI2

.040" ALUMINUM W/2" (51) INSUL.

OPTION CODE BG

20 GA. GALVANIZED STEEL

OPTION CODE BGI1

20 GA. GALVANIZED STEEL WITH
1" (25) INSULATION

OPTION CODE BGI2

20 GA. GALVANIZED STEEL WITH
2" (51) INSULATION

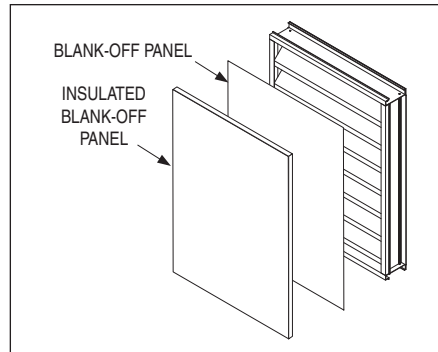

Certain louver applications may require that the airflow be controlled with a blank-off panel while still maintaining the louver's architectural appearance and aesthetic appeal. Blank-off panels can be a plain sheet of either galvanized steel or aluminum or a sandwich type panel in which 1" (25) or 2" (51) insulation attached. All Nailor extruded aluminum stationary louvers are available with blank-off panels; contact your Nailor representative Industries for steel stationary louvers.

SLEEVE TYPES:

OPTION CODE S304

TYPE 304 STAINLESS STEEL

OPTION CODE SALV

ALUMINUM

OPTION CODE SGLV

GALVANIZED STEEL

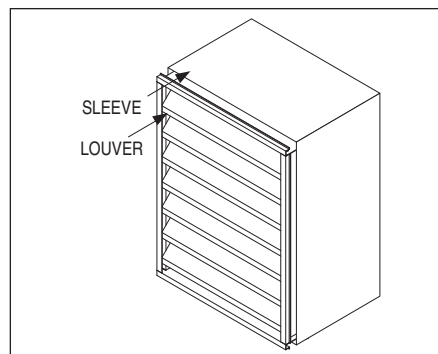

A factory installed louver sleeve allows the units to ship directly to jobsite ready for installation, saving time, money and costly field fabrication and mounting, as well as helping to ensure proper installation. Sleeves are available in a variety of construction and thickness: Galvanized steel sleeve (20 ga. [1.0], 18 ga. [1.3], 16 ga. [1.6], 14 ga. [2.0], 12 ga. [2.7] or 10 ga. [3.5]), Aluminum sleeve (16 ga. [1.6], 14 ga. [2.0], 10 ga. [3.5]) or Type 304 stainless steel sleeve (20 ga. [1.0], 18 ga. [1.3], 16 ga. [1.6], 14 ga. [2.0], 12 ga. [2.7] or 10 ga. [3.5]). All Nailor louvers are available with factory installed sleeves.

SECURITY BARS:

OPTION CODE SECB

SECURITY BARS

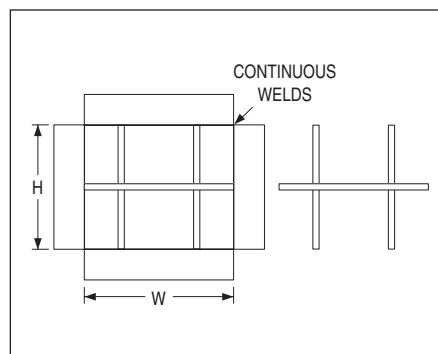

When combined with a sleeve, security bars provide maximum protection for installations where penetration through a wall needs to be secure. Available in a 2" (51) flat steel frame welded continuously at the corners, a variety of bar designs, bar material, construction types and bar spacing is available. Contact your Nailor representative for security bar requirements for all Nailor louvers.

Available Louver Finishes

Nailor offers 21 standard paint colors for architectural exterior use which meet or exceed AAMA specifications and performance requirements for color retention, chalk resistance, gloss retention, erosion, corrosion and chemical resistance as well as dry film thickness and hardness. Our state-of-the-art powder coat system provides an environment friendly finishing solution with more uniform coverage and coating thickness. The result is an exceptional finish that better resists scratching, fading and general wear. Additional liquid coat facilities for special requirements complete our ability to provide unmatched beauty and durability for any application. Nailor also offers 6 standard anodized finishes. Custom color matching is also available upon request. Contact your local Nailor representative.

See inside cover for available louver finishes color chart.

Note: Due to the printing process, colors shown approximate as closely as possible to the actual paint colors.

FINISH TYPE:	DESCRIPTION:
--------------	--------------

Fluoropolymer Powder Coat

AAMA 2605 - Superior Finish
(AKA: Powdura® 5000,
Corafon® Powder,
Interpon® D3000-Fluoromax)

"Ultimate" - A next generation hyper durable powder coating, based on FEVE fluoropolymer resins and ceramic pigmentation that the industry has acknowledged as the foundation for superior performance coatings. They provide a hard surface that is resistant to scratching and scuffing, with superior color and gloss retention, when applied to a variety of exterior architectural applications. This technology represents the "ultimate" in environmentally friendly finishes, with Zero-VOC emissions.

A new alternative to traditional 70% Kynar 500®/Hylar 5000® PVDF fluoropolymer liquid coatings.

High Performance Powder Coat

AAMA 2604 - High Performance Finish
(AKA: Powdura® 4000,
Envirocron® Ultra Durable Powder,
Dynadure™ 400, Interpon® D2000)

"Better" - A high performance polyester powder coating, based on "super durable" resins that utilize infrared reflective pigments, which provides excellent resistance to outdoor weathering. A harder and more environmentally friendly coating than other liquid paint counterparts and with Zero-VOC emissions.

A good alternative to 50% Kynar 500®/Hylar 5000® liquid coatings.

Durable Powder Coat

AAMA 2603 - Pigmented Organic Coatings
(AKA: Powdura® 3000,
Envirocron® Durable Powder,
Dynadure™ 300, Interpon® D1000)

"Good" - A durable powder coat based on thermosetting polyester resin technology. Provides a good economical combination of physical and chemical resistance properties. Environmentally superior to liquid spray paints and Zero - VOC emissions.

Clear Anodize 215-R1

AA-M10C22A41 (0.7 mil. min.)

Architectural Class I. Clear, colorless and hard oxide aluminum coating that resists weathering and chemical attack. Recommended for severely corrosive and abrasive atmospheric exposure.

Clear Anodize 204-R1

AA-M10C22A31 (0.4 - 0.7 mil.)

Architectural Class II. Clear, colorless and hard oxide aluminum coating that resists weathering and chemical attack. Recommended for normal weather exposure.

Color Anodize

AA-M10C22A44 (0.7 mil. min.)

Architectural Class I. "Two-step" aluminum coating process. Following a standard anodizing procedure, a second electrolytic process deposits colored metallic pigments which penetrate the aluminum oxide pores, producing a corrosion resistant, colorfast finish. Available in light, medium, dark bronze and black.

Prime Coat

Prime coat provides a stable base for painting of louvers in the field. Surface pretreatment includes degreasing and a chemical cleaning before an epoxy prime coat is applied. Finish coat should be field applied as soon as possible for best adhesion, after a thorough cleaning for dust etc. that can contaminate the final finish and cause premature flaking or peeling.

Contact your local representative for Color Guide and paint warranty information. Paint finish warranties are not applicable to steel products. Powdura® is a registered trademark of The Sherwin-Williams Company. Corafon® and Envirocron® are registered trademarks of PPG Industries Ohio, Inc. Interpon® is a registered trademark of Akzo Nobel Powder Coatings Ltd. Kynar 500® is a registered trademark of Arkema, Inc. Hylar 5000® is a registered trademark of Solvay Solexis, Inc.



Slate Blue LF01



Medium Bronze LF02



Sandstone LF03



Light Gray LF04



Charcoal LF05



Bone White LF06



Western Tan LF07



Architectural Bronze LF08



Legal Blue LF09



Forest Green LF10



Surrey Beige LF11



Royal Brown LF12



Barn Red LF13



Burgundy LF14



Clay LF15

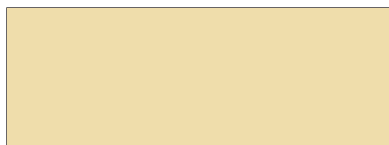

Almond LF16



Coastal White LF17



Vista Green LF18



Black LF19



Gloss Black LF20



Campus Green LF21

Nailor offers 21 standard paint colors selected for architectural exterior use which meet or exceed AAMA specifications and performance requirements for color retention, chalk resistance, gloss retention, erosion, corrosion and chemical resistance as well as dry film thickness and hardness. Our state-of-the-art powder coat system provides an environment friendly finishing solution with more uniform coverage and coating thickness. The result is an exceptional finish that better resists scratching, fading and general wear. Additional liquid coat facilities for special requirements complete our ability to provide unmatched beauty and durability for any application.

Custom color matching is also available upon request. Contact your local Nailor representative.

Note: Due to the printing process, colors shown approximate as closely as possible to the actual paint colors.