

## MODELS 1201-MDG & 1201-MDS MULTI-BLADE MARINE FIRE DAMPERS AIRFOIL BLADE • LOW LEAKAGE

Model Series 1201-MDG and 1201-MDS are Multi-Blade Low Leakage Fire Dampers for use in marine applications which require USCG approval for installation on Class A-60 divisions. Unique airfoil blade design provides low pressure drop, particularly suited for high velocity applications. Standard features include a rugged hat channel frame, 12" (305) factory fitted sleeve, concealed in-frame linkage and stainless steel jamb seals for low leakage performance. Models 1201-MDG and 1201-MDS may be installed vertically, with blades running horizontal, or horizontally.



Model 1201-MDG



Model 1290F

## MODEL 1290F-SS (1 1/2 HR.) DYNAMIC FIRE DAMPER TRUE ROUND • STAINLESS STEEL

Model 1290FSS is an economical true round fire damper designed and qualified for point-of-origin fire containment in high humidity or corrosive environments where round ductwork passes through metal stud drywall partitions or masonry walls that have a fire resistance rating of up to 2 hours and building codes require a fire damper. Features include the industry proven over-center/knee lock design with high torque spring/fusible link closure which provides fail-safe security during fire conditions under airflow. Each damper is supplied as standard with retaining plates for fast secure installation and a hand locking quadrant which holds the damper in the fully open position, but may also be used for system balancing if required. The 1290F-SS is available in either Type 304 or 316 Stainless Steel.

## MODEL 1290F (1 1/2 HR.) DYNAMIC FIRE DAMPER TRUE ROUND

Model 1290F is an economical true round fire damper designed and qualified for point-of-origin fire containment where round ductwork passes through metal stud drywall partitions or masonry walls that have a fire resistance rating of up to 2 hours and building codes require a fire damper. Features include the industry proven over-center/knee lock design with high torque spring/fusible link closure which provides fail-safe security during fire conditions under airflow. Each damper is supplied as standard with retaining plates for fast secure installation and a hand locking quadrant which holds the damper in the fully open position, but may also be used for system balancing if required.



Model 1290F-SS

- TRUE ROUND DESIGN
- EXCELLENT PERFORMANCE
- LOW PRESSURE DROP
- UL 555 CLASSIFIED DYNAMIC FIRE DAMPER

**Model:**

**1290F 1 1/2 Hour Label (for fire separations up to 2 hours)**



Model 1290F

Model 1290F True Round Fire Damper is designed and qualified specifically for applications where round ductwork passes through metal stud drywall partitions or masonry walls and building codes require a fire damper for the protection of ductwork penetrations in walls or floors that have a fire resistance rating of up to 2 hours. The 1290F is classified for use in dynamic "fans on" systems where the HVAC system remains operative in the event of a fire, and damper closure under airflow is assured.

The 1290F design features the industry proven over-center knee lock design with high torque spring/fusible link closure, economical galvanized steel construction, heavy duty 14 ga. (2.0) laminated blade and long life self-lubricating bearings. Available in large range of round sizes from 6" – 24" with a multitude of options, supplied as standard with a crank arm and locking screw which holds the damper in the fully open position, but may also be used for system balancing if required.

**QUALIFICATIONS:**

- **UL 555 & CAN/ULC-S112 CLASSIFIED DYNAMIC FIRE DAMPER 1 1/2 hr. Label (File # R9492).**
- **Meets NFPA 80, 90A and 101 as well as IBC and NBC (Canada) Building Code requirements.**
- **California State Fire Marshal: Fire Damper Listing No. 3225-0935:0101.**
- **Maximum velocity: 2000 fpm @ 4" w.g. (10 m/s @ 1 kPa).**

**STANDARD CONSTRUCTION:**

- Frame:** 20 ga. (1.0) galvanized steel integral sleeve and retaining plates.
- Blade:** 2 x 20 ga. (1.0) galvanized steel laminated together. 14 ga. (2.0) equivalent thickness.
- Linkage:** Jackshaft to blade.
- Bearings:** 1/2" (13) dia. self-lubricating oilite bronze.
- Axles:** 1/2" (13) dia. plated steel double bolted to blades.
- Jackshaft:** 1/2" (13) dia. cadmium plated steel. Supplied with factory mounted hand locking quadrant.
- Fusible Link:** 165°F (74°C) standard. 212°F (100°C) available.

**Model 1290F Sizes (Duct Dia.):**

| Minimum       | Maximum        |
|---------------|----------------|
| 6" (152) dia. | 24" (610) dia. |

**Note:** Dampers available in 1" (25) increments. Vertical or horizontal installation.

| Wall Thickness        | Min. Sleeve Length |
|-----------------------|--------------------|
| 4 to 8 (102 to 203)   | 16 (406)           |
| 10 to 12 (254 to 305) | 20 (508)           |
| 14 to 16 (356 to 406) | 24 (610)           |

**COMMON OPTIONS:**

- MLS-300 Position Indicator Switch Pack.

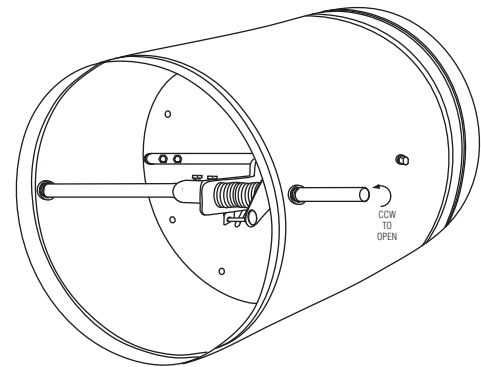

**MODEL 1290F  
1 1/2 HOUR LABEL  
(Retaining Plates not shown)**

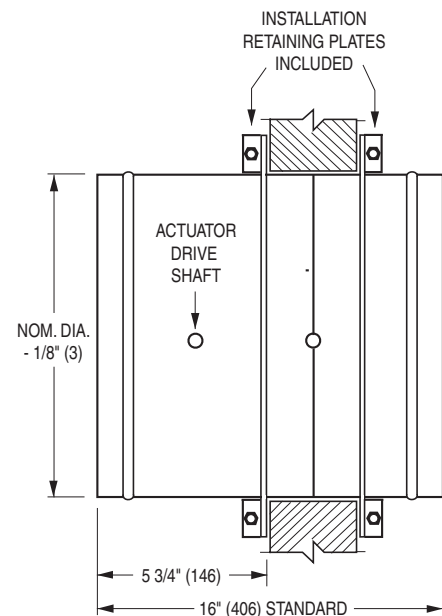

## PERFORMANCE DATA:

MODEL SERIES: 1290F - 1 1/2 HOUR LABEL AND 1290F-SS - 1 1/2 HOUR LABEL

### PRESSURE DROP

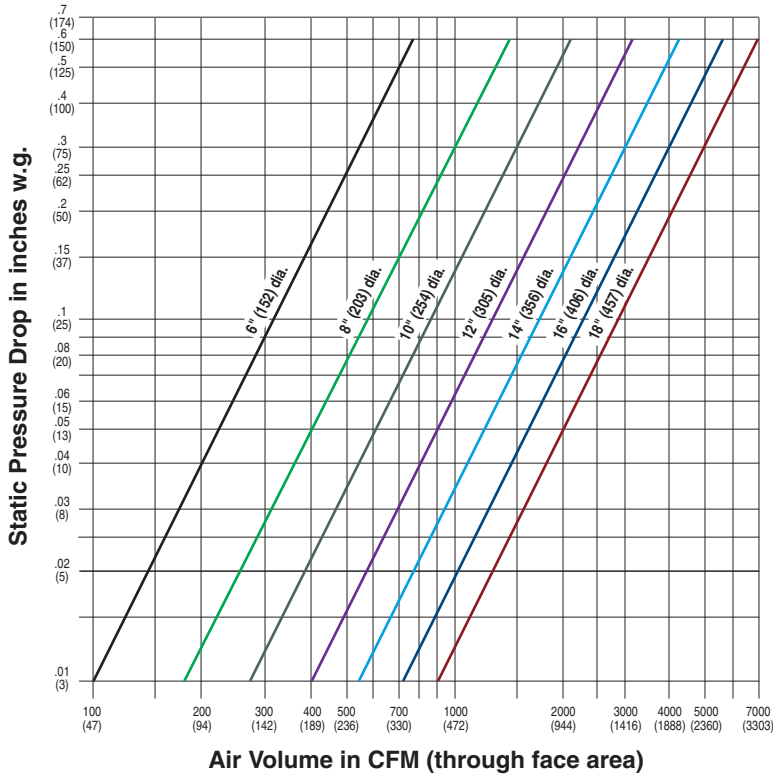

Pressure Drop tested per AMCA Standard 500-D, Fig. 5.5.

| 1290F Maximum Performance Ratings |                    |
|-----------------------------------|--------------------|
| UL 555 Fire Rating                | 1 1/2 Hour         |
| Maximum Velocity                  | 2000 fpm (10 m/s)  |
| Maximum Pressure                  | 4 in. w.g. (1 kPa) |

| 1290F-SS Maximum Performance Ratings |                    |
|--------------------------------------|--------------------|
| UL 555 Fire Rating                   | 1 1/2 Hour         |
| Maximum Velocity                     | 2000 fpm (10 m/s)  |
| Maximum Pressure                     | 4 in. w.g. (1 kPa) |

## HOW TO SPECIFY

## TRUE ROUND FIRE DAMPERS

## MODEL: 1290F - 1 1/2 HOUR LABEL

**SUGGESTED SPECIFICATION:**

Provide and install, as shown on plans and/or schedules True Round Dynamic Fire Dampers as manufactured by Nailor Industries, Inc. which meet or exceed the following criteria: Fire dampers shall meet the requirements of NFPA 80, 90A and 101 and shall be manufactured, tested and labeled in accordance with UL 555. Each damper shall bear a UL fire resistance rating label of 1 1/2 hours and in addition, a label verifying the airflow and closure pressure rating of 2000 fpm (10 m/s) at 4" w.g. (1 kPa) static pressure differential, as established by the Dynamic Closure Test. Each fire damper shall also be marked with the words "For use in dynamic systems". Dampers marked "For use in static systems only" are not acceptable.

Frame/integral sleeve shall be roll-formed from 20 ga. (1.0) galvanized steel, beaded for structural strength and grooved to accept 20 ga. (1.0) galvanized steel retaining plate. Required sleeve length shall be field verified by contractor. Each damper shall be complete with retaining plate and 20 ga. (1.0) galvanized steel damper plate, supplied by the damper manufacturer to ensure proper fit and installation. Blade shall be of two 20 ga. (1.0) galvanized steel pieces laminated together with an equivalent thickness of 14 ga. (2.0). Blades axles shall be 1/2" (13) dia. plated steel double bolted to blade. Hex, square friction-fit or press-fit axles are not acceptable. Bearings shall be self-lubricating oilite bronze type.

Each fire damper shall be complete with a (**specifier select temperature**) 165°F (74°C) or 212°F (100°C) UL Listed fusible link that will cause the damper to close and lock in closed position by means of an over center/knee lock linkage for assured closure. Each damper shall be supplied with an internal manual quadrant(s) for setting and locking of blades in desired position. Contractor shall provide and install an access door at each fire damper, of appropriate size to allow for inspection, testing and fusible link replacement. Data submitted for approval shall include confirmation of UL qualifications in addition to manufacturer's installation instructions. Each shipment of fire dampers shall include same installation instructions. Standard of acceptance shall be Nailor Model 1290F.

## STAINLESS STEEL TRUE ROUND FIRE DAMPERS

## MODEL: 1290F-SS - 1 1/2 HOUR LABEL

**SUGGESTED SPECIFICATION:**

Provide and install, as shown on plans and/or schedules Stainless Steel True Round Dynamic Fire Dampers as manufactured by Nailor Industries, Inc. which meet or exceed the following criteria: Fire dampers shall meet the requirements of NFPA 80, 90A and 101 and shall be manufactured, tested and labeled in accordance with UL 555. Each damper shall bear a UL fire resistance rating label of 1 1/2 hours and in addition, a label verifying the airflow and closure pressure rating of 2000 fpm (10 m/s) at 4" w.g. (1 kPa) static pressure differential, as established by the Dynamic Closure Test. Each fire damper shall also be marked with the words "For use in dynamic systems". Dampers marked "For use in static systems only" are not acceptable.

Frame/integral sleeve shall be from 20 ga. (1.0) stainless steel, beaded for structural strength and grooved to accept 20 ga. (1.0) stainless steel retaining plate. Required sleeve length shall be field verified by contractor. Each damper shall be complete with retaining plate and 20 ga. (1.0) stainless steel damper plate, supplied by the damper manufacturer to ensure proper fit and installation. Blade shall be of two 20 ga. (1.0) stainless steel pieces laminated together with an equivalent thickness of 14 ga. (2.0). Blades axles shall be 1/2" (13) dia. plated stainless steel double bolted to blade. Hex, square friction-fit or press-fit axles are not acceptable. Bearings shall be self-lubricating oilite bronze type.

Each fire damper shall be complete with a (**specifier select temperature**) 165°F (74°C) or 212°F (100°C) UL Listed fusible link that will cause the damper to close and lock in closed position by means of an over center/knee lock linkage for assured closure. Each damper shall be supplied with an internal manual quadrant(s) for setting and locking of blades in desired position. Contractor shall provide and install an access door at each fire damper, of appropriate size to allow for inspection, testing and fusible link replacement. Data submitted for approval shall include confirmation of UL qualifications in addition to manufacturer's installation instructions. Each shipment of fire dampers shall include same installation instructions. Standard of acceptance shall be Nailor Model 1290F-SS.

## HOW TO ORDER

### MULTI-BLADE & TRUE ROUND FIRE DAMPERS

**MODEL SERIES: D1200, D1200-3, D1200SS, D1200SS-3, D1201-OW, D1201-DOW, D1250, 1290F, 1290F-SS, 1200, 1200-3, 1200SS, 1200SS-3**

**EXAMPLE: D1251 - 24 x 24 - V - 24 - FL - 165 - BO - SL = 16 - 20G - L8**

#### 1a. Models

##### Dynamic or Static Applications

|           |   |
|-----------|---|
| D1200     | Airfoil Blade, 1 1/2 Hour Label   |
| D1200-3   | Airfoil Blade, 3 Hour Label   |
| D1200SS   | Stainless Steel,<br>Airfoil Blade, 1 1/2 Hour Label                     |
| D1200SS-3 | Stainless Steel,<br>Airfoil Blade, 3 Hour Label                         |
| D1201-OW  | Out-Of-Wall Airfoil Blade,<br>1 1/2 Hour Label,<br>Grille Mount         |
| D1201-DOW | Out-Of-Wall Airfoil Blade,<br>1 1/2 Hour Label,<br>Through Penetrations |
| D1250     | Vee Blade, 1 1/2 Hour Label   |
| 1290F     | True Round,<br>1 1/2 Hour Label   |
| 1290F-SS  | Stainless Steel,<br>True Round,<br>1 1/2 Hour Label                     |

##### Static Only Applications

|          |   |
|----------|---|
| 1200     | Airfoil Blade, 1 1/2 Hour Label                     |
| 1200-3   | Airfoil Blade, 3 Hour Label                         |
| 1200SS   | Stainless Steel,<br>Airfoil Blade, 1 1/2 Hour Label |
| 1200SS-3 | Stainless Steel,<br>Airfoil Blade, 3 Hour Label     |

#### 1b. Sleeve/Enclosure Style

(4th digit not applicable to all models)

- 0 = No Sleeve
- 1 = Type A Sleeve
- 2 = Type B Sleeve Enclosure
- 3 = Type C Sleeve Enclosure

#### 2. Duct Size

Width x Height or Diameter (inches [mm's])

#### 3. Construction

(Stainless Steel models only)

- 304 Type 304 Stainless Steel (default)
- 316 Type 316 Stainless Steel

#### 4. Mounting

- V Vertical (wall)
- H Horizontal (floor)

#### 5. Max. Velocity/Pressure Rating

(Dynamic models only)

- 24 2000 fpm @ 4" w.g. (default)
- 34 3000 fpm @ 4" w.g.
- 44 4000 fpm @ 4" w.g.

#### 6. Closure Device

- FL Fusible Link (default)

#### 7. Closure Temperature

- 165 165°F (default)
- 212 212°F

#### 8. Bearings

- BO Oilite Bronze (default)
- BS Stainless Steel (default on  
Stainless Steel models)

#### 9. Jamb Seals

- (Not applicable to all models)
- None
- JSM Flexible metal
- JSS Stainless steel

#### 10. Blade Seals

- (Not applicable to all models)
- None
- BSS Silicone (D1250 Series only)

#### 11a. Side Mounting Plate

- (No sleeve models only)
- SMP Side Mounting Plate

#### 11b. Sleeve Length

- SL = Specify**
- 16" (406) standard (default)
- 16" – 36" (406 – 914)

#### 12. Sleeve Gauge

- 20G 20 ga. standard (default)
- 18G 18 ga.
- 16G 16 ga.
- 14G 14 ga.
- 10G 10 ga.

#### 13. Transition

- (Sleeve Type C models only)
- CR Round
- CO Oval
- CSR Square/Rectangular

#### 14. Damper Location

- L8 8" (203) from sleeve end
- LX Other (specify)  
8" – 16" (203 – 406)

#### ACCESSORIES:

##### 15. Retaining Angles

- None (default)
- QS1 Single set (Not available on  
Model D1201-DOW)
- QS2 Pair (Not available on  
Model D1201-OW)

##### 16. Position Indicator

- None (default)
- 300 MLS-300 (4-wire)

##### 17. TDF Flange

- (Type A sleeved models only)
- None (default)
- TDF1 One end
- TDF2 Both ends

#### Notes:

1. Not all variants and options are available on all models. Refer to individual model for selection availability.
2. One MLS-300 required per damper assembly.
3. All multi-blade fire dampers are supplied with a locking quadrant.

## Options and Accessories

Nailor multi-blade fire dampers are tested by and listed with Underwriters Laboratories Inc. and are manufactured within UL procedural requirements. Approved variables including a variety of options and accessories are available to suit specific applications.

### MATERIAL OPTIONS:

**OPTION CODE 304**  
STAINLESS STEEL CONSTRUCTION

All parts of damper (except blade seals) will be constructed of 304 stainless steel. Provides higher corrosion resistance against harsh atmospheric and process elements. Consult your Nailor representative for specific application suitability.

**OPTION CODE 316**  
STAINLESS STEEL CONSTRUCTION

All parts of damper (except blade seals) will be constructed of 316 stainless steel. Provides higher corrosion resistance against harsh atmospheric and process elements. Consult your Nailor representative for specific application suitability.

### BEARING OPTIONS:

**OPTION CODE BO**  
OILITE® BRONZE BEARINGS



Bronze sintered (oil impregnated) self-lubricating oilite bearings provide long time lubrication making them ideal for use in applications where proper maintenance is uncertain or difficult.

**OPTION CODE BS**  
STAINLESS STEEL BEARINGS



304 grade stainless steel bearings provide corrosion resistance in a wide variety of corrosive media. In higher heat applications, provides good oxidation resistance. Standard for stainless steel models.

### CLOSURE TEMPERATURES:

**OPTION CODES**  
**165 212**  
FUSIBLE LINK TEMPERATURE

Fusible links for Model Series (D)1200, D1250 and 1290F fire dampers are available with a choice of several melting temperature ratings. Nailor fire dampers are provided as standard with 165°F (74°C) fusible link. Optional 212°F (100°C) link can be installed on damper at time of manufacturing, or can be ordered separately as a replacement part for field installation as part of a regular maintenance program or after a fire emergency (providing damper is still functional).

The National Fire Protection Association Standard 90A states that "fusible links shall have a temperature rating approximately 50°F (28°C) above the maximum temperature that normally is encountered when the system is in operation or shut down, but not less than 160°F (71°C)." Adhering to this guideline helps prevent 'nuisance trips' resulting in unnecessary replacement costs and labor time. Note that local building codes may also stipulate a maximum closure temperature rating.

## OPTIONAL SEALS:

OPTION CODE **JSM**  
FLEXIBLE METAL JAMB SEALS

OPTION CODE **JSS**  
STAINLESS STEEL JAMB SEALS

OPTION CODE **BSS**  
SILICONE SEALS

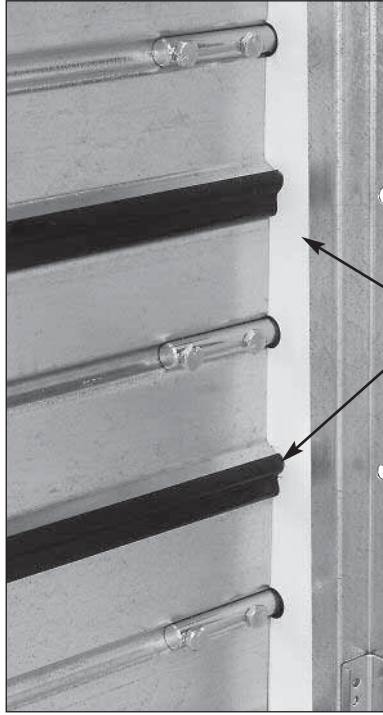

Option Code JSM (Option Code JSS on stainless steel models) provides damper with flexible metal jamb seals to minimize air leakage between blade ends and frame. Suitable for use in applications that may require damper to be used as a shut-off damper for example, as well as a fire damper.

JSM JSS

BSS

Option Code BSS provides damper with Silicone blade edge seals. Blade seals minimize air leakage between blades, and are a suitable option for use in applications that may require damper to be used as a shut-off damper for example, as well as a fire damper.

## RETAINING ANGLES:

OPTION CODES  
**QS2** TWO SIDES (PAIR)  
**QS1** ONE SIDE  
 'QUICK-SET' RETAINING ANGLES

### FOR USE WITH ALL MULTI-BLADE FIRE DAMPERS EXCEPT MODELS 1290FS AND 1290FS-SS

- Maximum Size: 90" x 48" (2286 x 1219) or 48" x 90" (1219 x 2286)

Note: Reference IOM-FDQSRA for more details.

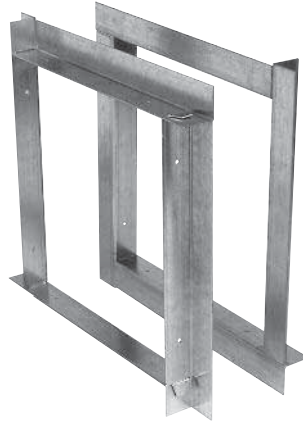

#### BENEFITS:

- Factory fabricated by the manufacturer to suit the individual fire damper.
- Dampers can ship directly to the job site complete with all necessary installation sheet metal hardware (saves on double handling at contractor's shop).
- Reduced cost when compared to conventional retaining angles.
- Only two sets of angles to handle per damper (rather than eight).
- Angles ship with individual damper - no sorting or matching.
- Pre-drilled holes on 8" (203) centers to ensure correct angle/sleeve attachment.
- Help ensure a correct installation as per U.L. approved installation instructions.

The majority of installing contractors view fire damper installation as a costly time consuming and troublesome procedure. Eight conventional angles must be custom fabricated for each damper either in a sheet metal shop or at the job site and sized to suit each individual damper. Invariably, they are mislaid or lost and must be matched to each factory supplied damper. The Nailor "Quick-Set" solution solves the majority of problems. They are pre-formed to fit each damper and shipped with the individual damper units for ultimate convenience.

Nailor "Quick-Set" retaining angles are an accessory option for all dampers ordered with factory sleeves.

**QS2:** Two sides (pair). For standard installations where angles are installed on both sides of the fire partition.

**QS1:** One side (single set). For use in a single side retaining angle installations and with grille mount and "out of wall" damper models. "Quick-Set" angles are supplied with correctly spaced pre-drilled screw-holes to ensure a quick, easy and accurate installation for all Nailor fire dampers - no measuring required.

"Quick-Set" retaining angles when specified and supplied with Nailor integral sleeve fire dampers provide the "complete" installation package. Simple, fast, convenient.

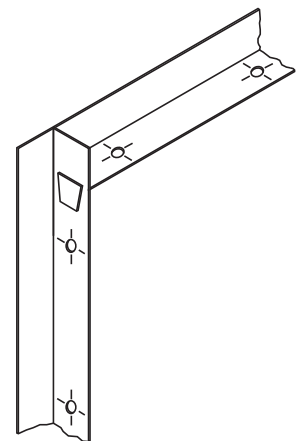
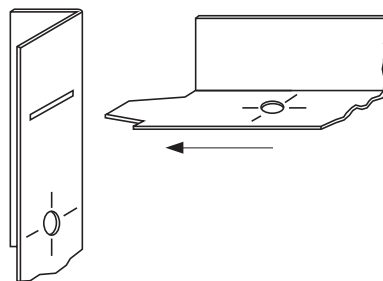
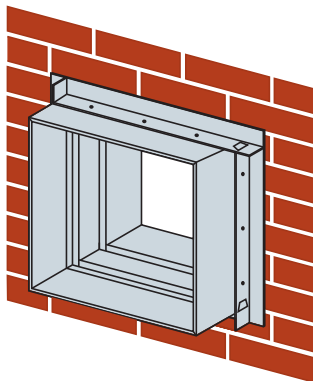

**Style 1:** 1 1/2" x 1 1/2" x 20 ga. (38 x 38 x 1.0) Four sides are connected together with rivets in three corners. Standard for the majority of applications with the following limitations:

- 1 1/2 hour label fire dampers.
- Maximum Size: 36" x 36" (914 x 914).
- Two sided installation only.

**Style 2:** 1 1/2" x 1 1/2" x 16 ga. (38 x 38 x 1.6) Slot and tab design. The retaining angle assembly for each side has four angles, each with a tab end and a slot end (Detail A). The tabs are to be inserted into the slots and knocked down either before or after fastening to the sleeve (Detail B).

- 1 1/2 or 3 hour label fire dampers.
- Maximum Size: 90" x 48" (2286 x 1219) or 48" x 90" (1219 x 2286).
- Single side (1 1/2 hour only. Refer to Single Side Retaining Angles Supplementary Installation Instructions for size limitations) or two sided installation.



## SLEEVES OR SIDE MOUNTING PLATE:

**TYPE A SLEEVES**  
MODELS (D)1201 and D1251

All fire dampers require a steel sleeve of correct length and gauge in order to be installed in accordance with the product's UL approved installation instructions. Nailor recommends that all multi-blade fire dampers, including Type A models, are specified and ordered complete with a factory installed full sleeve (Type B and C models are manufactured as standard with a transition casing that acts as a sleeve). Nailor can provide a factory furnished sleeve that allows the units to ship directly to job site ready for installation, saving time, money and costly shop or field fabrication, as well as helping to ensure proper installation to UL requirements. A factory furnished sleeve also permits factory mounting of Nailor's MLS-300 Position Indicator Switch Pack. Standard sleeve is 16" (406) long. For further damper/sleeve details, see Models (D)1201 and D1251.

The following indicates model numbers to order for multi-blade fire dampers with factory fitted Type A sleeves:

| Standard Model # | With Type A Sleeve |
|------------------|--------------------|
| (D)1200          | Model (D)1201      |
| D1250            | Model D1251        |

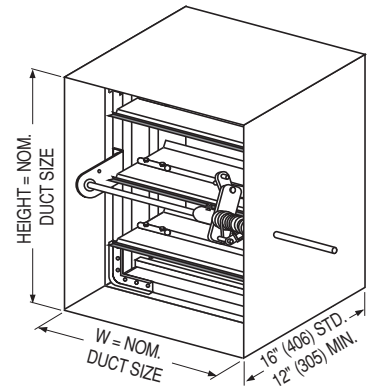

**OPTION CODE SMP**  
SIDE MOUNTING PLATE

Nailor's **SMP**, Side Mounting Plate is required for factory mounting of the MLS-300 Position Indicator Switch Pack when a full factory sleeve is not requested. As with all fire dampers, an appropriate steel sleeve is required for installation of damper in wall or floor.

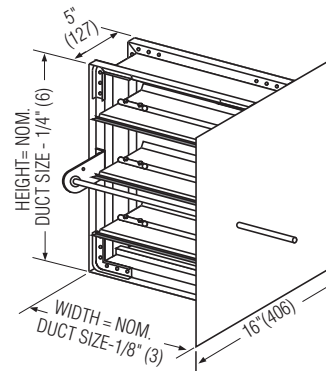

**SIDE MOUNTING PLATE FOR MULTI-BLADE FIRE DAMPERS**

## FLANGED SLEEVE:

OPTION CODES  
 TDF FLANGE  
**TDF2** BOTH ENDS  
**TDF1** ONE END



**TDF** (by Engle) and **TDC** (by Lockformer) proprietary flange systems are approved as breakaway connections for connecting a combination fire/smoke damper Type A sleeve (22 or 20 gauge) to ductwork. They may be used in place of the approved slip joints shown in standard installation instructions. For Option **TDF1** the sleeve is factory flanged on one end only. For Option **TDF2** the sleeve is factory flanged on both ends.

Note that the maximum wall/floor opening size permitted by UL, relative to the damper size, may not physically allow the flange to fit through the opening. Consultation and co-ordination with the wall/floor contractor is recommended. **TDF1**, flange on one end only, will permit the non-flanged end of the sleeve to fit through the opening. Specify which end to be flanged in relation to the jackshaft.

|   |
|---|
| <b>Maximum TDF1/TDF2 Sleeve Size Allowed:</b>                       |
| For Curtain Type Fire Damper: 60" wide x 60" high (1524 x 1524).    |
| For Multi-Blade Type Fire Damper: 36" wide x 48" high (914 x 1219). |

Note: Reference IOM-FDTDCFINST for more details.