

## GENERAL PRODUCT OVERVIEW

### Security Products

Nailor offers a complete line of Security Grilles, Registers and Diffusers. The product line includes grilles and registers for maximum, medium and minimum security and a diffuser for minimum security applications. The grilles and registers that are for use in the highest security areas are constructed from very heavy gauge welded steel that provides exceptional strength and durability. A wide range of options and accessories are available that can enhance the strength and performance of the grilles and registers.

#### MAXIMUM SECURITY GRILLES & REGISTERS

Nailor's maximum security grilles and registers are constructed from heavy gauge welded steel and are for use in areas where maximum security is vital. These grilles can be used for both supply and return air applications.

**Lattice Face w/Mesh** Model SG-LM  
**Perforated Face Plate** Model SG-PR

**Page H5**  
**Page H8**

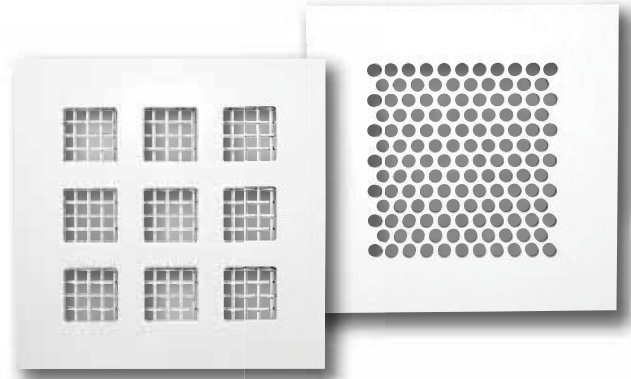

Models SG-LM & SG-PR



Model SG-BM4

#### MEDIUM/MINIMUM SECURITY GRILLES & REGISTERS

This sidewall bar grille is constructed from 14 gauge steel and has blades that are fixed at 40° or 0° deflection. The louvered blade and steel mesh screen are reinforced with heavy gauge steel mullions and a welded sleeve. These grilles can be used for both supply and return air applications.

**40° Deflection** Model SG-BM4  
**0° Deflection** Model SG-BMZ

**Page H11**  
**Page H11**

#### MINIMUM SECURITY DIFFUSERS

These diffusers are a combination of a louvered pattern diffuser with a lattice face plate for minimum security protection. The diffusers are available with a choice of 1, 2, 3 or 4-way throw patterns. Use these diffusers in applications where constant supervision occurs.

**Steel** Model SG-6500  
**Aluminum** Model SG-6200

**Page H13**  
**Page H13**

Suffix '-O' adds an opposed blade damper.

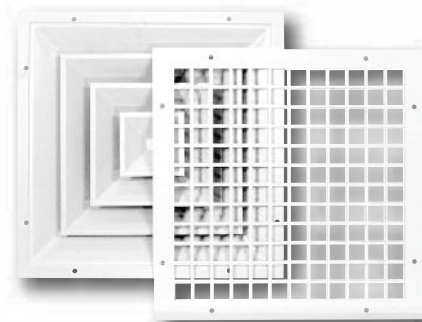

Model SG-6500



Model SG-480

#### MINIMUM SECURITY BAR GRILLES & REGISTERS

These minimum security bar grilles are all aluminum rust-proof construction, which makes them ideal for use in showers and wet areas. The frame and blades are welded for extra strength. These grilles have 0° deflection blades that are spaced on either 1/2" (13) or 1/4" (6) centers.

**1/2" (13) Spacing** Model SG-280  
**1/4" (6) Spacing** Model SG-480

**Page H15**  
**Page H15**

## MAXIMUM SECURITY GRILLES AND REGISTERS

- SUPPLY OR RETURN
- STEEL CONSTRUCTION
- SQUARE LATTICE FACE
- MESH SCREEN

**Model:**  
**SG-LM**

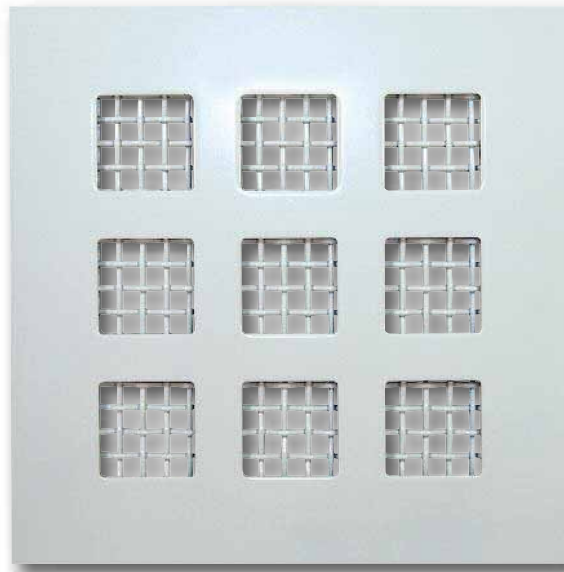

Model SG-LM

Model SG-LM meets the industry standard for maximum security applications. It can be used as a supply or return grille where maximum security is paramount, supervision is minimal and absolute grille integrity must be maintained. These units are constructed of welded heavy gauge steel that allows the grille to become an integral part of the wall structure, providing additional strength.

### STANDARD FEATURES:

- Face Plate: 3/16" (5) steel lattice plate with 2" (51) square holes and 1" (25) fret bars.
- Backer Plate: 3/16" (5) steel lattice plate standard to match face.
- Sleeve: 3/16" (5) steel, of length required, with continuously welded seams and stitch welded to face plate.
- Protective screen sandwiched between face and backer plate.
- 10 gauge x 3/8" (10) clear opening (No. 2 mesh) woven steel wire.

### FINISH OPTIONS:

- Standard finish is prime coat for field painting.

### OPTIONS & ACCESSORIES:

- Mounting Angles: Option A, B or C. See page H24.
- Masonry Anchor Tabs: Option D. See page H24.
- Additional Security Barrier: Option E, F, G or H. See page H24.

- Opposed Blade Damper: Option J, Face operator (screwdriver slot). Option K, Rear operator (screwdriver slot). See page H25.
- Adjustable Blade Packs: Single deflection: Option L, horizontal blades. Option M, vertical blades. Double deflection: Option N, horizontal front blades. Option P, vertical front blades. See page H25.

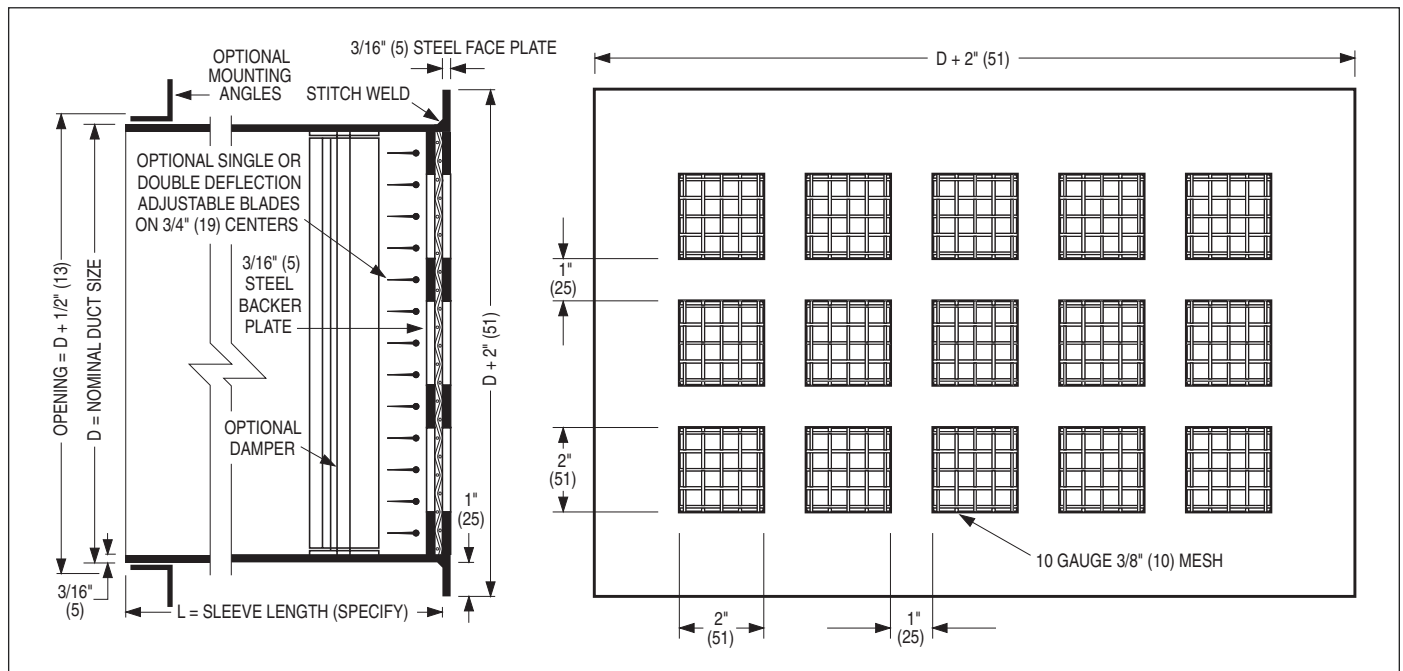

## PERFORMANCE DATA:

### MODEL SG-LM • SUPPLY

Neck Size	FPM TP	100 0.011	150 0.026	200 0.046	250 0.072	300 0.103	350 0.141	400 0.184	450 0.232	500 0.287
6 x 6	CFM	25	38	50	63	75	88	100	113	125
	NC	—	—	—	14	19	23	27	30	33
	T	2-3-6	3-5-10	4-6-12	5-8-13	6-10-14	8-11-15	9-12-17	10-12-17	11-12-18
9 x 6	CFM	38	56	75	94	113	131	150	169	188
	NC	—	—	11	16	21	25	29	32	35
	T	2-4-8	4-6-12	5-8-14	7-10-16	8-12-17	9-14-19	11-14-20	12-15-21	13-16-23
12 x 6	CFM	50	75	100	125	150	175	200	225	250
	NC	—	—	13	19	25	29	32	34	38
	T	3-4-9	4-7-13	6-9-16	8-12-18	9-14-20	11-15-22	13-16-24	14-19-25	15-18-26
15 x 6	CFM	63	94	125	156	188	219	250	281	313
	NC	—	—	15	21	26	30	34	37	40
	T	3-5-10	5-8-15	7-10-18	9-12-21	10-15-23	12-17-25	13-18-26	15-19-28	17-21-29
18 x 6	CFM	75	113	150	188	225	263	300	338	375
	NC	—	—	16	22	27	31	35	38	41
	T	3-5-11	5-8-16	7-11-20	9-13-23	11-16-25	13-19-27	14-20-29	16-21-30	18-23-32
21 x 6	CFM	88	131	175	219	263	306	350	394	438
	NC	—	—	17	23	28	32	35	39	41
	T	4-6-12	6-9-18	8-12-22	10-15-25	12-18-27	14-20-29	17-22-31	18-23-33	20-25-34
24 x 6	CFM	100	150	200	250	300	350	400	450	500
	NC	—	—	17	23	38	32	36	39	42
	T	4-6-13	6-10-19	9-13-24	11-16-26	13-19-29	15-22-31	17-24-33	19-25-35	22-26-37
9 x 9	CFM	56	84	113	141	169	197	225	253	281
	NC	—	—	14	20	25	29	33	36	39
	T	3-5-10	5-7-14	6-10-17	8-12-19	10-14-21	12-16-23	13-17-25	14-18-27	16-19-28
12 x 9	CFM	75	113	150	188	225	263	300	338	375
	NC	—	—	16	22	27	31	35	38	41
	T	3-5-11	5-8-16	7-11-20	9-14-23	11-16-25	13-19-27	14-20-29	16-21-30	18-23-32
15 x 9	CFM	94	141	188	234	281	328	375	422	469
	NC	—	—	16	23	28	32	36	39	42
	T	4-6-12	6-10-19	8-12-23	11-15-26	12-19-28	14-21-30	16-23-32	19-24-34	21-26-36
18 x 9	CFM	113	169	225	281	338	394	450	506	563
	NC	—	—	18	24	29	33	37	40	43
	T	4-7-13	7-10-20	9-13-25	12-17-28	13-20-30	16-23-33	18-25-35	20-21-37	23-28-39
21 x 9	CFM	131	197	263	328	394	459	525	591	656
	NC	—	—	19	25	30	34	35	41	44
	T	5-7-14	7-11-22	10-14-27	13-18-30	14-22-33	17-25-35	20-29-38	22-29-40	25-30-43
24 x 9	CFM	150	225	300	375	450	525	600	675	750
	NC	—	—	19	25	30	35	38	41	44
	T	5-8-15	8-12-24	11-15-29	13-20-32	15-24-35	18-27-38	21-29-41	24-30-43	26-32-46
12 x 12	CFM	100	150	200	250	300	350	400	450	500
	NC	—	—	17	23	28	32	36	39	42
	T	4-6-13	6-10-19	9-12-24	11-16-26	13-19-29	15-22-32	17-24-34	19-25-36	21-26-38
15 x 12	CFM	125	188	250	313	375	438	500	563	625
	NC	—	11	18	24	29	34	37	40	43
	T	5-7-13	7-11-22	10-14-26	12-18-30	14-22-33	17-25-35	19-26-38	22-28-40	24-30-42
18 x 12	CFM	150	225	300	375	450	525	600	675	750
	NC	—	12	19	25	30	35	38	41	44
	T	5-8-15	8-12-24	11-15-29	13-20-33	15-24-36	18-27-39	21-29-41	24-30-43	26-32-46
21 x 12	CFM	175	263	350	438	525	613	700	788	875
	NC	—	12	20	26	31	35	39	42	45
	T	6-9-17	9-12-26	12-17-31	14-21-34	17-26-38	20-29-41	23-31-44	26-33-47	29-34-50
24 x 12	CFM	200	300	400	500	600	700	800	900	1000
	NC	—	13	21	27	32	36	40	43	46
	T	6-9-18	9-13-28	12-18-33	15-23-37	18-28-41	21-31-44	25-33-48	28-35-50	30-37-52

**CFM** - cubic feet per minute

**FPM** - feet per minute velocity

**TP** - total pressure - inches w.g.

**T** - throw in feet

**NC** - Noise Criteria (values) based on 10 dB room absorption, re 10<sup>-12</sup> watts.

#### Performance Notes:

1. Performance data is based on supply air and standard construction.
2. Throws are given at 150, 100 and 50 fpm terminal velocities under isothermal conditions.
3. Return Performance:

Negative static pressure approximates to listed total pressure.

Add + 2 to listed NC value.

4. Data derived from tests conducted in accordance with ANSI/ASHRAE Standard 70 – 2006.

## PERFORMANCE DATA:

### MODEL SG-LM • SUPPLY

Neck Size	FPM TP	100 0.011	150 0.026	200 0.046	250 0.072	300 0.103	350 0.141	400 0.184	450 0.232	500 0.287
15 x 15	CFM	156	234	313	391	469	547	625	703	781
	NC	—	12	20	26	31	35	38	42	44
	T	5-8-16	8-12-24	11-16-30	13-20-32	16-24-37	19-28-39	22-30-42	24-31-44	27-32-47
18 x 15	CFM	188	281	375	469	563	656	750	844	938
	NC	—	13	21	27	32	36	39	43	45
	T	6-9-17	9-13-27	12-17-32	14-22-36	17-27-39	21-30-43	24-32-46	27-34-49	30-36-52
21 x 15	CFM	219	328	438	547	656	766	875	984	1094
	NC	—	13	21	27	32	37	40	43	46
	T	6-10-19	10-14-29	13-19-34	16-24-39	19-29-43	22-32-46	26-34-50	29-37-53	31-39-56
24 x 15	CFM	250	375	500	625	750	875	1000	1125	1250
	NC	—	14	22	28	33	37	41	42	47
	T	7-10-20	10-15-30	13-20-37	17-26-42	20-30-46	24-34-50	28-37-53	30-39-57	34-42-60
18 x 18	CFM	225	338	450	563	675	788	900	1013	1125
	NC	—	14	22	28	33	37	40	43	46
	T	6-10-19	10-14-29	13-19-35	16-24-39	19-30-43	23-33-47	26-35-51	30-37-54	32-39-57
21 x 18	CFM	263	394	525	656	788	919	1050	1181	1313
	NC	—	14	22	28	33	37	41	44	47
	T	7-11-21	11-15-31	14-21-38	17-26-43	21-31-47	25-35-51	28-38-55	31-40-58	34-43-62
24 x 18	CFM	300	450	600	750	900	1050	1200	1350	1500
	NC	—	15	23	29	34	38	42	45	48
	T	7-11-22	11-16-33	15-22-41	18-28-46	22-33-51	26-38-55	30-41-59	33-43-62	37-46-66
21 x 21	CFM	306	459	613	766	919	1072	1225	1378	1531
	NC	—	15	23	29	34	38	42	45	48
	T	8-12-24	12-17-34	15-23-41	19-29-46	22-34-51	27-39-55	30-41-59	34-44-63	37-46-67
24 x 21	CFM	350	525	700	875	1050	1225	1400	1575	1750
	NC	—	16	24	30	35	39	43	46	49
	T	8-12-25	12-18-36	16-24-44	20-30-50	24-36-55	29-41-59	33-45-64	36-47-68	40-50-71
24 x 24	CFM	400	600	800	1000	1200	1400	1600	1800	2000
	NC	—	17	25	31	36	40	43	46	49
	T	9-13-26	13-19-39	17-26-48	22-33-53	26-39-59	31-44-64	35-48-68	39-51-73	43-53-77

**CFM** - cubic feet per minute

**FPM** - feet per minute velocity

**TP** - total pressure - inches w.g.

**T** - throw in feet

**NC** - Noise Criteria (values) based on 10 dB room absorption, re 10<sup>-12</sup> watts.

#### Performance Notes:

1. Performance data is based on supply air and standard construction.
2. Throws are given at 150, 100 and 50 fpm terminal velocities under isothermal conditions.
3. Return Performance:

Negative static pressure approximates to listed total pressure.

Add + 2 to listed NC value.

4. Data derived from tests conducted in accordance with ANSI/ASHRAE Standard 70 – 2006.

## MAXIMUM SECURITY GRILLES AND REGISTERS

- SUPPLY OR RETURN
- STEEL CONSTRUCTION
- PERFORATED FACE

**Model:**  
**SG-PR**

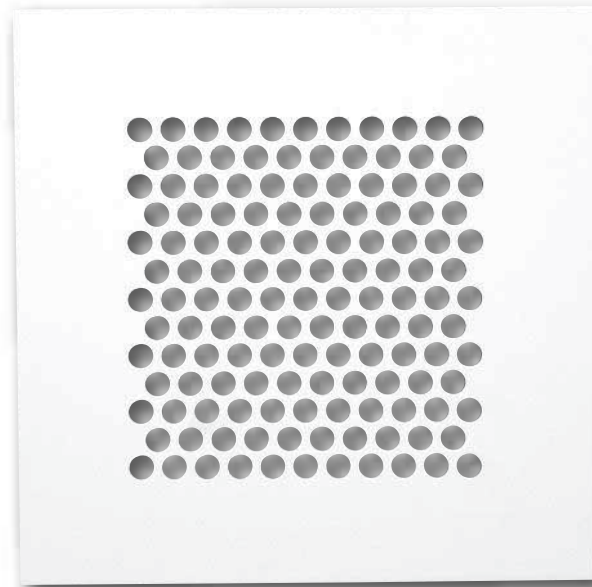

Model SG-PR

Model SG-PR is utilized in maximum security areas. Its design features a perforated face plate with 5/16" (8) dia. holes that allows a greater effective free area, but still upholds the required level of security and safety. It can be used as a supply or return grille. These units are constructed of welded heavy gauge steel that allows the grille to become an integral part of the wall structure, providing additional strength.

### STANDARD FEATURES:

- Face Plate: 3/16" (5) steel lattice plate with 5/16" (8) dia. holes on staggered 7/16" (11) centers.
- Sleeve: 3/16" (5) steel, of length required, with continuously welded seams and stitch welded to face plate.

### FINISH OPTIONS:

- Standard finish is prime coat for field painting.

### OPTIONS & ACCESSORIES:

- Mounting Angles: Option A, B or C. See page H24.
- Masonry Anchor Tabs: Option D. See page H24.
- Additional Security Barrier: Option E, F, G or H. See page H24.
- Opposed Blade Damper: Option J, Face operator (screwdriver slot).

Option K, Rear operator (screwdriver slot). See page H25.

• Adjustable Blade Packs:  
Single deflection: Option L, horizontal blades. Option M, vertical blades. Double deflection: Option N, horizontal front blades. Option P, vertical front blades. See page H25.

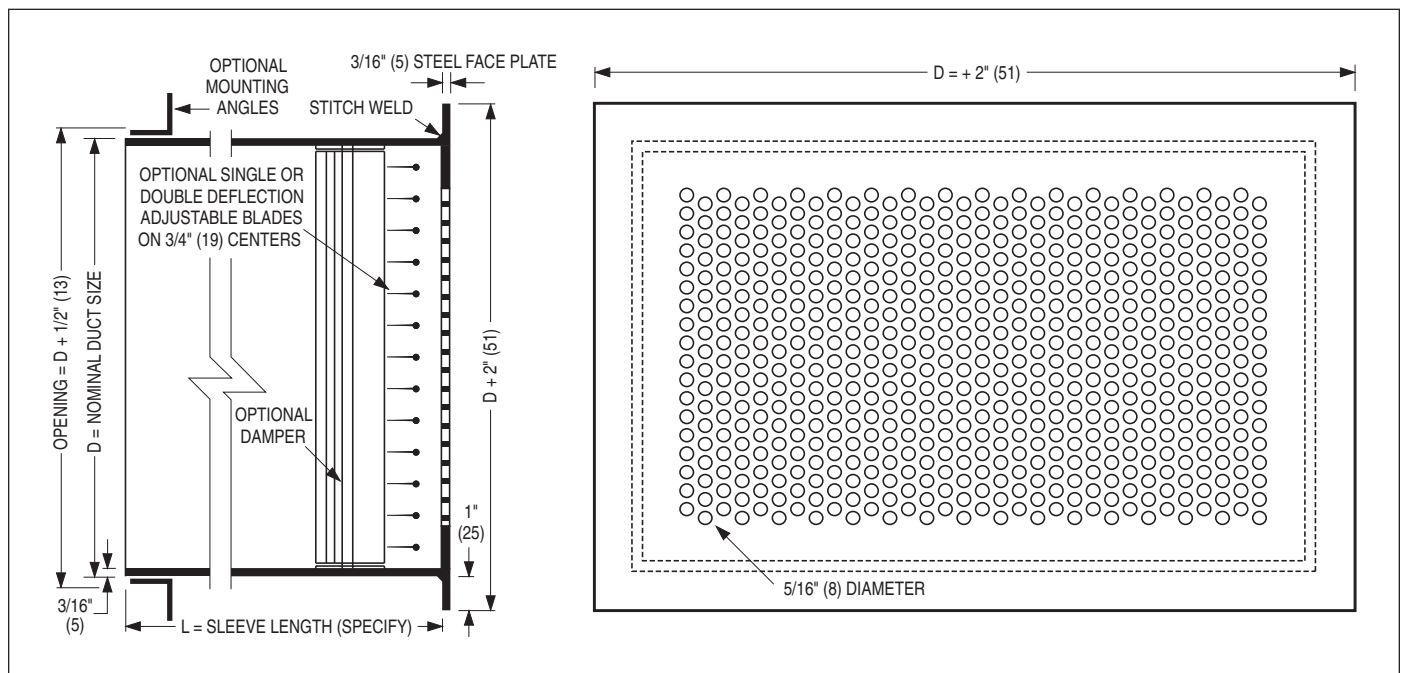

## PERFORMANCE DATA:

### MODEL SG-PR • SUPPLY

Neck Size	FPM TP	100 0.005	150 0.011	200 0.020	250 0.031	300 0.044	350 0.060	400 0.079	450 0.100	500 0.123
6 x 6	CFM	25	38	50	63	75	88	100	113	125
	NC	—	—	—	—	12	16	20	24	27
	T	1-2-5	2-3-7	3-5-10	4-6-12	5-7-12	5-8-13	6-10-14	7-11-15	8-12-16
9 x 6	CFM	38	56	75	94	113	131	150	169	188
	NC	—	—	—	—	14	18	22	25	29
	T	2-3-6	3-4-9	4-6-12	5-7-14	6-9-15	7-10-17	8-12-18	9-13-19	10-14-20
12 x 6	CFM	50	75	100	125	150	175	200	225	250
	NC	—	—	—	—	15	19	23	27	30
	T	2-3-7	3-5-10	4-7-13	6-9-16	7-10-18	8-12-10	9-13-21	10-15-22	12-16-24
15 x 6	CFM	63	94	125	156	188	219	250	281	313
	NC	—	—	—	—	16	20	24	28	31
	T	2-4-8	4-6-12	5-8-17	6-10-18	8-12-20	9-13-22	10-15-24	12-17-25	13-18-27
18 x 6	CFM	75	113	150	188	225	263	300	338	375
	NC	—	—	—	11	17	21	25	28	32
	T	2-4-8	4-6-12	5-8-16	7-11-20	8-12-22	10-14-24	11-16-26	12-18-28	13-20-29
21 x 6	CFM	88	131	175	219	263	306	350	394	438
	NC	—	—	—	12	18	22	26	29	32
	T	3-4-9	4-7-13	6-9-18	7-11-22	9-13-24	11-15-26	12-18-28	13-20-29	14-22-31
24 x 6	CFM	100	150	200	250	300	350	400	450	500
	NC	—	—	—	12	18	22	26	30	33
	T	3-5-10	5-7-14	6-10-19	8-12-24	10-14-26	11-16-28	13-19-29	14-21-33	16-24-34
9 x 9	CFM	56	84	113	141	169	197	225	253	281
	NC	—	—	—	—	15	20	24	27	30
	T	2-3-7	3-5-11	5-7-14	6-9-17	7-11-19	8-12-21	10-14-22	11-16-24	12-17-25
12 x 9	CFM	75	113	150	188	225	263	300	338	375
	NC	—	—	—	11	17	21	25	28	32
	T	2-4-8	4-6-12	5-8-16	7-11-20	8-12-22	10-14-24	11-16-26	12-18-28	13-20-29
15 x 9	CFM	94	141	188	234	281	328	375	422	469
	NC	—	—	—	12	18	22	26	29	33
	T	3-4-9	4-7-13	6-9-18	8-12-23	9-13-25	11-16-27	12-18-29	13-21-30	15-23-32
18 x 9	CFM	113	169	225	281	338	394	450	506	563
	NC	—	—	—	13	18	23	27	30	33
	T	3-5-10	5-8-15	7-10-20	9-12-25	10-15-28	12-17-29	13-20-31	15-23-33	17-25-35
21 x 9	CFM	131	197	263	328	394	459	525	591	656
	NC	—	—	—	14	19	24	27	31	34
	T	3-5-11	5-8-16	7-11-22	9-13-27	11-16-29	12-19-32	14-22-34	16-25-36	18-27-38
24 x 9	CFM	150	225	300	375	450	525	600	675	750
	NC	—	—	—	14	19	24	28	31	35
	T	4-6-12	6-9-17	8-12-23	10-14-29	12-17-31	13-20-34	15-23-36	17-27-39	19-29-41
12 x 12	CFM	100	150	200	250	300	350	400	450	500
	NC	—	—	—	13	18	22	26	30	33
	T	3-5-10	5-7-14	6-10-19	8-12-24	10-14-26	11-16-28	12-19-29	14-21-31	16-24-33
15 x 12	CFM	125	188	250	313	375	438	500	563	625
	NC	—	—	—	13	19	23	27	31	34
	T	3-5-11	5-8-16	7-11-21	9-13-27	11-16-29	12-18-31	14-21-33	16-24-35	18-27-37
18 x 12	CFM	150	225	300	375	450	525	600	675	750
	NC	—	—	—	14	20	24	28	31	35
	T	4-6-12	6-9-17	8-12-23	10-14-29	12-17-31	13-20-34	15-23-36	17-27-39	19-29-41
21 x 12	CFM	175	263	350	438	525	613	700	788	875
	NC	—	—	—	15	21	25	29	32	35
	T	4-6-12	6-10-19	8-13-25	11-15-31	12-19-34	14-22-37	16-25-39	19-29-42	21-32-44
24 x 12	CFM	200	300	400	500	600	700	800	900	1000
	NC	—	—	—	15	21	25	29	33	36
	T	4-7-13	7-10-20	9-14-27	12-17-33	14-20-36	15-24-39	18-27-42	20-30-45	23-33-48

**CFM** - cubic feet per minute

**FPM** - feet per minute velocity

**TP** - total pressure - inches w.g.

**T** - throw in feet

**NC** - Noise Criteria (values) based on 10 dB room absorption, re 10<sup>-12</sup> watts.

#### Performance Notes:

1. Performance data is based on supply air and standard construction.
2. Throws are given at 150, 100 and 50 fpm terminal velocities under isothermal conditions.
3. Return Performance:

Negative static pressure approximates to listed total pressure.

Add + 2 to listed NC value.

4. Data derived from tests conducted in accordance with ANSI/ASHRAE Standard 70 – 2006.

## PERFORMANCE DATA:

### MODEL SG-PR • SUPPLY

Neck Size	FPM TP	100 0.011	150 0.026	200 0.046	250 0.072	300 0.103	350 0.141	400 0.184	450 0.232	500 0.287
15 x 15	CFM	156	234	313	391	469	547	625	703	781
	NC	—	—	—	14	20	24	28	32	35
	T	4-6-12	6-9-18	8-12-24	10-14-29	12-18-32	14-21-35	16-24-37	18-27-40	20-29-42
18 x 15	CFM	188	281	375	469	563	656	750	844	938
	NC	—	—	—	15	21	25	29	32	35
	T	4-6-13	6-10-19	9-13-26	11-16-33	13-19-36	15-23-38	17-26-41	19-29-44	22-33-46
21 x 15	CFM	219	328	438	547	656	766	875	984	1094
	NC	—	—	—	15	21	26	30	33	36
	T	5-7-14	7-11-22	10-14-28	12-17-35	14-21-38	16-25-42	19-29-44	21-31-47	24-35-50
24 x 15	CFM	250	375	500	625	750	875	1000	1125	1250
	NC	—	—	—	16	22	26	30	34	37
	T	5-8-15	8-12-23	10-15-29	13-19-37	15-23-41	17-27-44	20-30-48	23-34-51	25-37-54
18 x 18	CFM	225	338	450	563	675	788	900	1013	1125
	NC	—	—	—	16	21	26	30	33	36
	T	5-7-14	7-11-21	10-14-29	11-18-35	14-21-39	16-25-42	19-28-45	21-32-48	24-35-51
21 x 18	CFM	263	394	525	656	788	919	1050	1181	1313
	NC	—	—	11	17	22	26	30	34	37
	T	5-8-15	8-12-23	11-15-31	12-19-38	15-23-42	18-27-46	21-31-49	23-35-52	25-38-55
24 x 18	CFM	300	450	600	750	900	1050	1200	1350	1500
	NC	—	—	11	17	23	27	31	34	38
	T	5-8-16	8-13-25	11-16-34	13-21-41	16-25-45	19-29-49	22-34-52	25-37-56	28-41-59
21 x 21	CFM	306	459	613	766	919	1072	1225	1378	1531
	NC	—	—	—	18	23	27	31	35	38
	T	5-8-16	8-13-25	11-16-33	13-21-41	16-25-46	19-29-49	22-34-53	25-38-56	29-41-59
24 x 21	CFM	350	525	700	875	1050	1225	1400	1575	1750
	NC	—	—	11	18	23	28	32	35	38
	T	6-9-18	9-14-27	12-18-36	14-22-44	18-27-49	21-31-53	24-36-57	27-40-60	30-44-64
24 x 24	CFM	400	600	800	1000	1200	1400	1600	1800	2000
	NC	—	—	12	18	24	28	32	36	39
	T	6-10-19	10-14-29	13-19-39	16-24-48	19-29-52	22-33-57	2-38-61	28-43-65	33-48-68

**CFM** - cubic feet per minute

**FPM** - feet per minute velocity

**TP** - total pressure - inches w.g.

**T** - throw in feet

**NC** - Noise Criteria (values) based on 10 dB room absorption, re 10<sup>-12</sup> watts.

#### Performance Notes:

1. Performance data is based on supply air and standard construction.

2. Throws are given at 150, 100 and 50 fpm terminal velocities under isothermal conditions.

3. Return Performance:

Negative static pressure approximates to listed total pressure.

Add + 2 to listed NC value.

4. Data derived from tests conducted in accordance with ANSI/ASHRAE Standard 70 – 2006.

## Options and Accessories

### MOUNTING ANGLES:

**Option A** 1" x 1" x 1/8" (25 x 25 x 3) welded rear angle frame. Shipped loose for field attachment (weld or bolt).

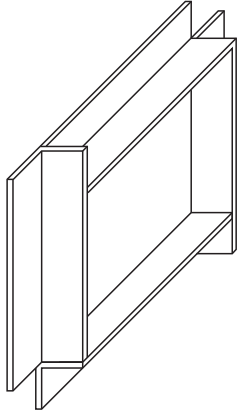

**Option B** 4 pcs. 1" x 1" x 1/8" (25 x 25 x 3) mounting angles, with holes and bolts. Shipped loose for field attachment.

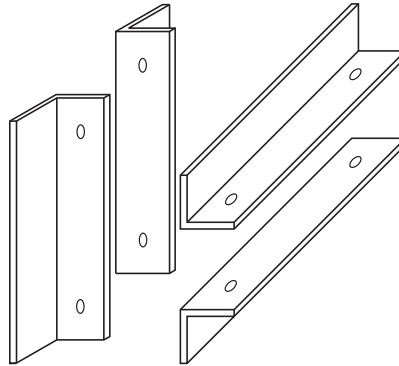

**Option C** 2 pcs. 1" x 1" x 1/8" (25 x 25 x 3) mounting angles (long dim.). Shipped loose for field attachment (weld or bolt).

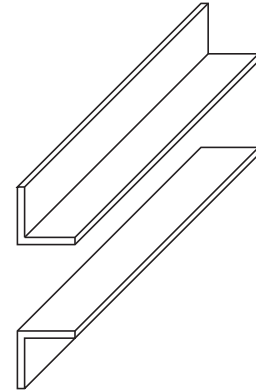

### MASONRY ANCHOR TABS AND SECURITY BARS:

**Option D** 1/2" (13) dia. steel anchor tabs. 3" (76) long for concrete or brick walls. Minimum one per side.

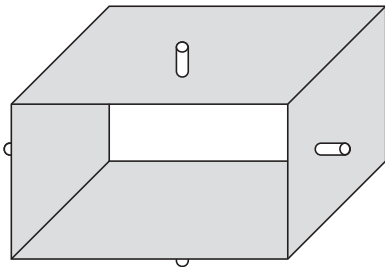

**Option E** 2 1/2" x 3/8" (64 x 10) flat security bars welded in sleeve, 4" (102) max. on center.

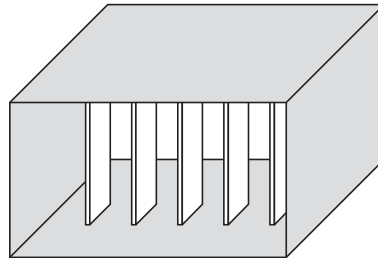

**Option F** 1/2" (13) dia. round security bars welded in sleeve, 6" (152) max. on center.

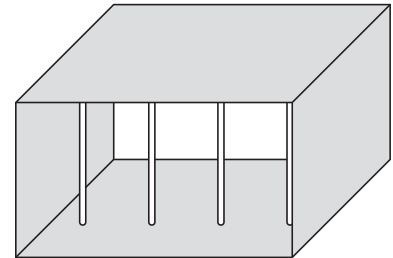

**Option G** Barrier Grille. 1/2" (13) dia. round security bars, vertical and horizontal, 6" (152) max. on center welded to sleeve and at each cross-point.

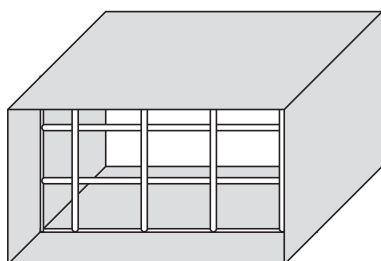

**Option H** Barrier Grille. 3/4" (19) dia. vertical bars with 2" x 1/4" (51 x 6) horizontal flat bars welded to sleeve and at each cross-point.

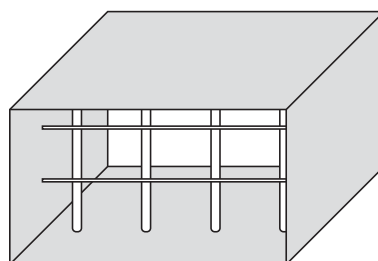



Options and Accessories

OPPOSED BLADE DAMPERS:

**Option J** Opposed Blade Damper. Face operator (screwdriver slot or lever).

**Option K** Opposed Blade Damper. Rear operator (screwdriver slot).

DIRECTIONAL BLADES:

**Option L** Adjustable single deflection horizontal blades on 3/4" (19) centers.

**Option M** Adjustable single deflection vertical blades on 3/4" (19) centers.

**Option N** Adjustable double deflection blades on 3/4" (19) centers. Horizontal front blades.

**Option P** Adjustable double deflection blades on 3/4" (19) centers. Vertical front blades.

**Important note for all options and accessories:**  
 Not all options shown, or certain combinations, are necessarily available on individual security products. Consult the individual model description to determine which options apply.