

GENERAL PRODUCT OVERVIEW

Security Products

Nailor offers a complete line of Security Grilles, Registers and Diffusers. The product line includes grilles and registers for maximum, medium and minimum security and a diffuser for minimum security applications. The grilles and registers that are for use in the highest security areas are constructed from very heavy gauge welded steel that provides exceptional strength and durability. A wide range of options and accessories are available that can enhance the strength and performance of the grilles and registers.

MAXIMUM SECURITY GRILLES & REGISTERS

Nailor's maximum security grilles and registers are constructed from heavy gauge welded steel and are for use in areas where maximum security is vital. These grilles can be used for both supply and return air applications.

Lattice Face w/Mesh Model SG-LM
Perforated Face Plate Model SG-PR

Page G5
Page G8

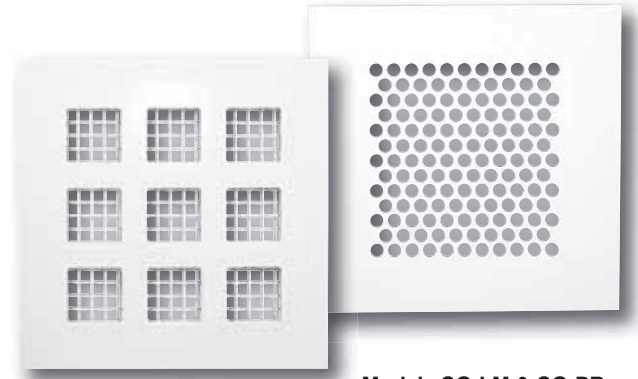

Models SG-LM & SG-PR



Model SG-BM4

MEDIUM/MINIMUM SECURITY GRILLES & REGISTERS

This sidewall bar grille is constructed from 14 gauge steel and has blades that are fixed at 40° or 0° deflection. The louvered blade and steel mesh screen are reinforced with heavy gauge steel mullions and a welded sleeve. These grilles can be used for both supply and return air applications.

40° Deflection Model SG-BM4
0° Deflection Model SG-BMZ

Page G11
Page G11

MINIMUM SECURITY DIFFUSERS

These diffusers are a combination of a louvered pattern diffuser with a lattice face plate for minimum security protection. The diffusers are available with a choice of 1, 2, 3 or 4-way throw patterns. Use these diffusers in applications where constant supervision occurs.

Steel Model SG-6500
Aluminum Model SG-6200

Page G13
Page G13

Suffix '-O' adds an opposed blade damper.

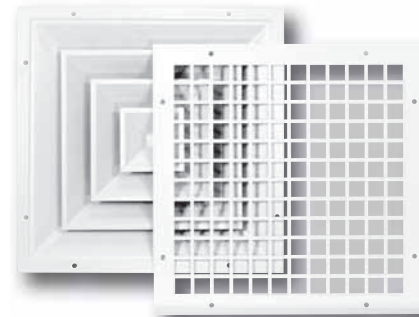

Model SG-6500



Model SG-480

MINIMUM SECURITY BAR GRILLES & REGISTERS

These minimum security bar grilles are all aluminum rust-proof construction, which makes them ideal for use in showers and wet areas. The frame and blades are welded for extra strength. These grilles have 0° deflection blades that are spaced on either 1/2" (13) or 1/4" (6) centers.

1/2" (13) Spacing Model SG-280
1/4" (6) Spacing Model SG-480

Page G15
Page G15

MINIMUM SECURITY GRILLES AND REGISTERS

- SUPPLY OR RETURN
- ALUMINUM CONSTRUCTION
- FIXED BARS 0° DEFLECTION

Models:

SG-280 1/2" (13) spacing

SG-480 1/4" (6) spacing

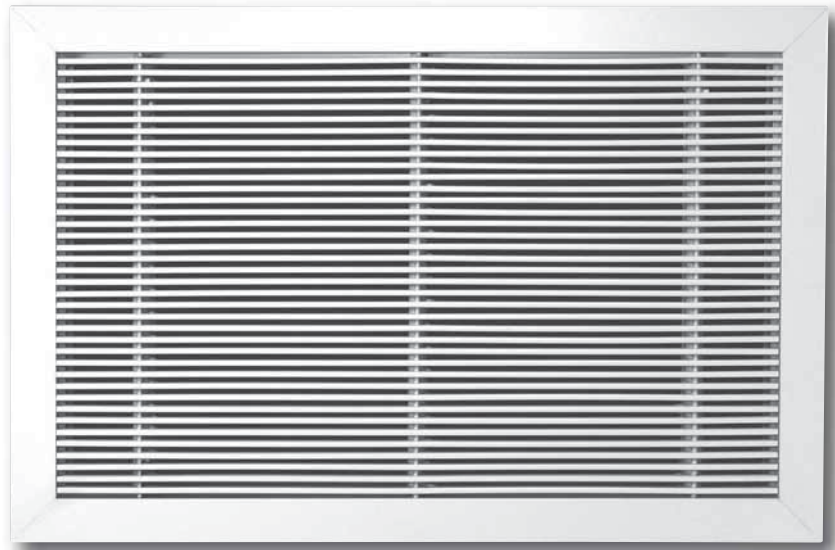

Model SG-480

Models SG-280 and SG-480 are all aluminum minimum security grilles. Rust-proof construction makes these models ideal for use in showers and wet areas where they are constantly exposed to humid conditions. Models have fixed 1/8" (3) thick, extruded horizontal bars on 1/4" (6) or 1/2" (13) centers. They are fixed at 0° deflection and are individually welded to their cross-bar spacers, which in turn are supported by heavy duty extruded aluminum members welded to the grille frame. This grille is securely fastened with a heavy gauge aluminum sleeve welded to the grille frame which passes through the wall. The sleeve is fastened with an optional extruded aluminum wall flange on the reverse side.

STANDARD FEATURES:

- Frame: Heavy gauge extruded aluminum with welded mitered corners.
- Bars: 1/8" (3) thick extruded aluminum on 1/4" (6) or 1/2" (13) centers, welded to cross-bars and supported by 1 1/8" x 3/8" (29 x 10) heavy duty extruded support members on maximum 6" (152) centers welded to frame.

- Sleeve: 10 gauge aluminum welded to frame. Length as specified to suit wall thickness.
- Available in sizes 6" x 6" (152 x 152) through 36" x 36" (914 x 914) in single piece construction.

FINISH OPTIONS:

- Standard finish is AW Appliance White. Other finishes are available.

OPTIONS & ACCESSORIES:

- Rear wall flange. Same construction as grille frame. Shipped loose to be field welded to sleeve.
- Mounting angles: Option A, B or C. See page G24.
- Opposed Blade Damper: Face operator (screwdriver slot or lever), Option J, Rear operator (screwdriver slot), Option K, see page G25.

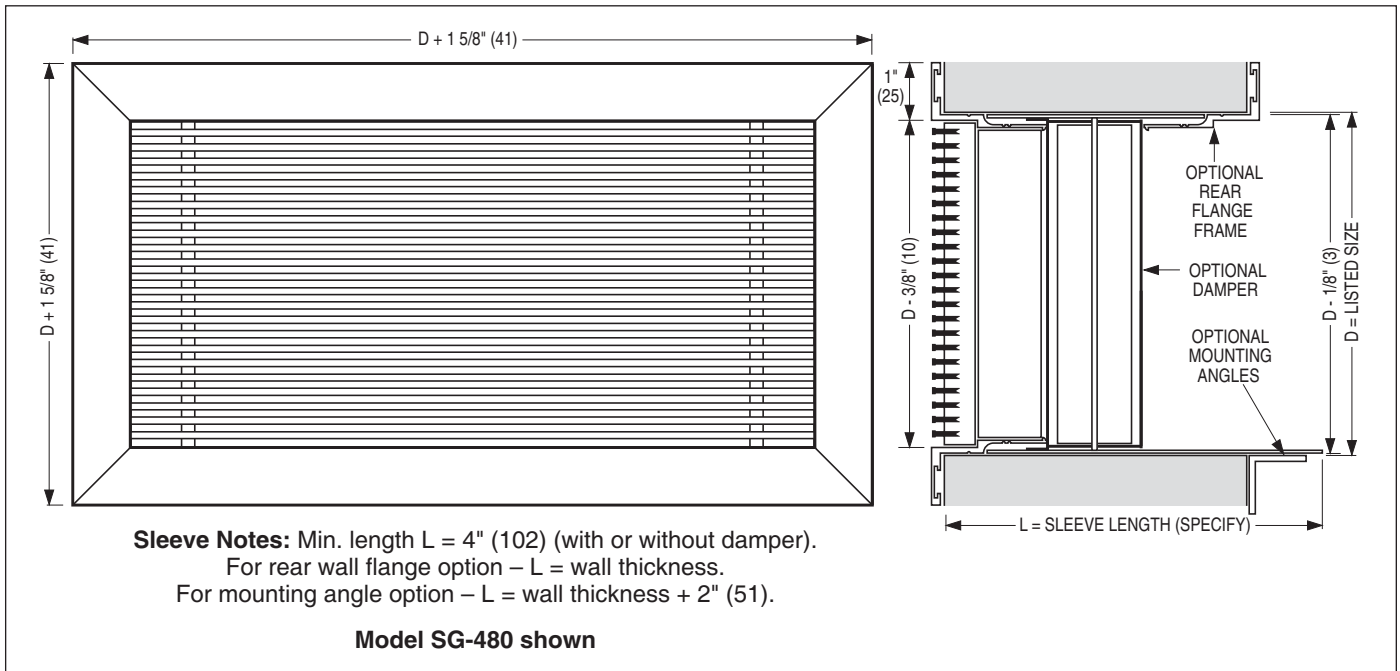

PERFORMANCE DATA:

MODEL SG-280 • SUPPLY

Core Area Sq. Feet	Nominal Duct Size, Inches		Core Velocity	300	400	500	600	800	1000	1200
			Total Pressure	.033	.055	.087	.120	.220	.338	.491
.18	8 x 4	6 x 6	CFM	55	70	90	110	145	180	215
			Noise Criteria	-	-	-	21	30	36	42
			Throw	6-9-13	7-10-14	10-12-16	11-13-18	12-14-21	14-17-23	15-18-26
			CFM	80	105	130	155	210	260	310
.26	12 x 4	8 x 6	Noise Criteria	-	-	-	22	31	37	43
			Throw	7-11-15	11-13-18	11-14-19	13-15-22	14-18-26	16-20-28	18-21-30
			CFM	155	210	260	310	415	520	625
			Noise Criteria	-	-	23	29	34	40	46
.52	24 x 4	16 x 6	Throw	10-14-22	12-17-25	16-20-27	18-23-31	21-26-37	23-29-40	25-31-44
			CFM	245	325	405	485	650	810	970
			Noise Criteria	-	-	25	30	37	43	47
			Throw	12-17-27	16-22-30	20-26-32	24-30-38	27-32-45	29-34-50	30-38-55
.81	14 x 10	16 x 8	CFM	480	640	800	960	1280	1600	1920
			Noise Criteria	-	-	26	31	38	44	50
			Throw	16-24-37	24-31-41	30-36-46	34-41-54	40-46-64	41-49-67	43-53-75
			CFM	835	1110	1320	1676	2220	2780	3340
2.78	30 x 14	24 x 18	Noise Criteria	-	21	27	34	41	47	53
			Throw	23-33-51	30-45-58	38-46-67	42-50-71	49-59-82	57-68-92	60-71-105
			CFM	1290	1720	2140	2570	3430	4290	5150
			Noise Criteria	-	23	29	36	43	49	56
4.29	30 x 22	28 x 24	Throw	27-39-63	37-53-73	44-58-81	50-63-92	60-73-105	66-80-119	70-85-130

MODEL SG-280 • RETURN

Core Area Sq. Feet	Nominal Duct Size, Inches		Core Velocity	200	300	400	500	600	800	1000
			Neg. Static Pressu	.011	.032	.053	.084	.116	.210	.326
.18	8 x 4	6 x 6	CFM	35	55	70	90	110	145	180
			Noise Criteria	-	-	-	-	21	28	34
			CFM	50	80	105	130	155	210	260
.39	12 x 4	8 x 6	Noise Criteria	-	-	-	-	24	30	37
			CFM	105	155	210	260	310	415	520
			Noise Criteria	-	-	-	25	29	36	42
.52	24 x 4	16 x 6	CFM	160	245	325	405	485	650	810
			Noise Criteria	-	-	22	28	32	39	45
			CFM	320	480	640	800	960	1280	1600
1.60	30 x 8	24 x 10	Noise Criteria	-	-	26	32	36	43	49
			CFM	555	835	1110	1390	1670	2220	2780
			Noise Criteria	-	22	30	36	40	48	53
2.78	30 x 14	24 x 18	CFM	860	1290	1720	2140	2570	3430	4290
			Noise Criteria	-	26	33	39	43	50	57

Performance Notes:

- All pressure are in inches w.g..
- Core Velocity is in feet per minute
- Throws are given at 150, 100 and 50 fpm terminal velocities.
- Correction factors for Model SG-480 are as follows:
Total Pressure = Listed value x 1.5
Noise Criteria level, add + 5 to listed value.
- Noise Criteria (NC) values are based upon 10dB room absorption, re 10⁻¹² watts. Dash (-) in space indicates an Noise Criteria of less than 15.
- Data derived from tests conducted in accordance with ANSI/ASHRAE Standard 70 – 2006.

Options and Accessories

MOUNTING ANGLES:

Option A 1" x 1" x 1/8" (25 x 25 x 3) welded rear angle frame. Shipped loose for field attachment (weld or bolt).

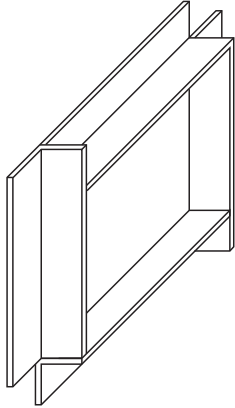

Option B 4 pcs. 1" x 1" x 1/8" (25 x 25 x 3) mounting angles, with holes and bolts. Shipped loose for field attachment.

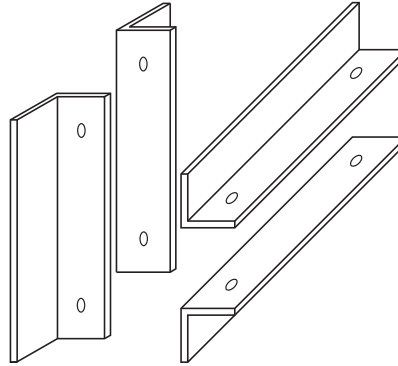

Option C 2 pcs. 1" x 1" x 1/8" (25 x 25 x 3) mounting angles (long dim.). Shipped loose for field attachment (weld or bolt).

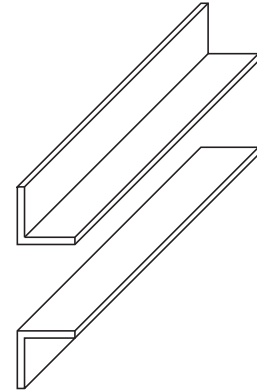

MASONRY ANCHOR TABS AND SECURITY BARS:

Option D 1/2" (13) dia. steel anchor tabs. 3" (76) long for concrete or brick walls. Minimum one per side.

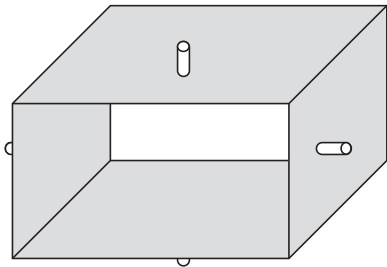

Option E 2 1/2" x 3/8" (64 x 10) flat security bars welded in sleeve, 4" (102) max. on center.

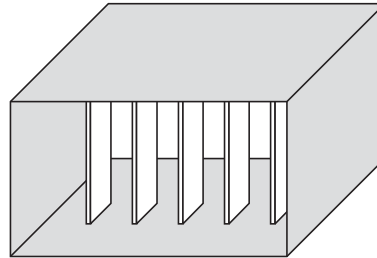

Option F 1/2" (13) dia. round security bars welded in sleeve, 6" (152) max. on center.

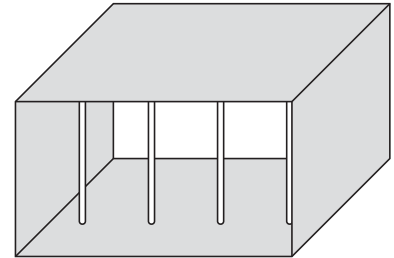

Option G Barrier Grille. 1/2" (13) dia. round security bars, vertical and horizontal, 6" (152) max. on center welded to sleeve and at each cross-point.

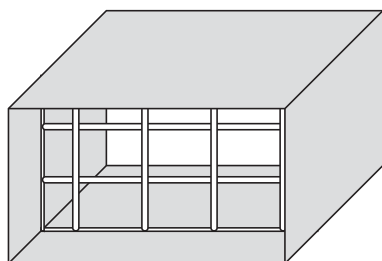

Option H Barrier Grille. 3/4" (19) dia. vertical bars with 2" x 1/4" (51 x 6) horizontal flat bars welded to sleeve and at each cross-point.

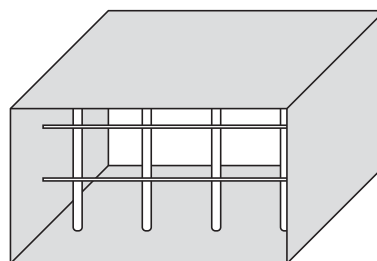

Options and Accessories

OPPOSED BLADE DAMPERS:

Option J Opposed Blade Damper. Face operator (screwdriver slot or lever).

Option K Opposed Blade Damper. Rear operator (screwdriver slot).

DIRECTIONAL BLADES:

Option L Adjustable single deflection horizontal blades on 3/4" (19) centers.

Option M Adjustable single deflection vertical blades on 3/4" (19) centers.

Option N Adjustable double deflection blades on 3/4" (19) centers. Horizontal front blades.

Option P Adjustable double deflection blades on 3/4" (19) centers. Vertical front blades.

Important note for all options and accessories:
 Not all options shown, or certain combinations, are necessarily available on individual security products. Consult the individual model description to determine which options apply.

