

GENERAL PRODUCT OVERVIEW

It is widely accepted that fire destroys property and smoke is responsible for the vast majority of fire related occupant deaths. Smoke dampers have two general applications: 1) They may be applied in a "Passive Smoke Control System" where they simply close and prevent the circulation of air and smoke through a duct or a ventilation opening in a smoke barrier, or 2) They may be applied as part of an "Engineered Smoke Control System" designed to control the spread of smoke using floors and walls as barriers. The latter method utilizes the building's HVAC system and/or dedicated fans to create pressure differences that surround a fire area to prevent the spread of smoke from the fire zone into other areas of the building. Smoke dampers are motorized with electric or pneumatic actuators and may be controlled by a smoke or heat detector signal, a fire alarm signal or in a variety of ways by the building control system to accomplish the intent of the design. Nailor Industries' commitment to the development of new and existing fire and smoke control technology has resulted in a comprehensive line of premium quality smoke dampers and accessories, available at a reasonable cost and in a timely fashion.

MODEL SERIES 1280 EXTRUDED ALUMINUM AIRFOIL BLADE PREMIUM PERFORMANCE

Model Series 1280 is the premium choice for applications where a leakage rated smoke damper is required as part of a static smoke control or dynamic smoke management system. The design features a smoothly contoured extruded aluminum airfoil blade and compression type seals that have been designed to offer the lowest leakage class available with airflow in either directions. Together with a concealed linkage, out of airstream, the design provides an ultra-low pressure drop and minimizes unwanted turbulence and noise generation. A rugged 16 ga. (2.0) frame with reinforced mitered corners and die-formed corner gussets combine performance with durability.



Model 1280



Model 1210

MODEL SERIES 1210 STEEL AIRFOIL BLADE STANDARD PERFORMANCE

Model Series 1210 Smoke Dampers feature an innovative inter-locking double skin steel airfoil blade design that eliminates the need for combustible blade seals that typically burn off during fire conditions. The unique blade design combines high performance and low pressure drop while providing complete flame and smoke seal. Available at standard dynamic velocity/pressure ratings of 2000 fpm @ 4" w.g. (10 m/s @ 1 kPa), UL tested for extended ratings up to 4000 fpm @ 8" w.g. (20 m/s @ 2 kPa), Model Series 1210 has been designed and tested to provide premium performance. Features include an economical steel airfoil blade, low pressure drop frame design and maintenance free concealed blade linkage for superb air performance, turbulence and noise.

MODEL SERIES 1260 VEE GROOVE BLADE

Nailor 1260 Series Smoke Dampers are a ruggedly built economical choice for use where a smoke barrier has been penetrated by ductwork or where a leakage rated smoke damper is required in a static or dynamic smoke control system. The 1260 Series dampers are classified to UL Standard 555S Class I or II at 250°F (121°C) or 350°F (177°C) Elevated Temperatures, and are available with type B and C enclosures for small sizes and round ductwork. Design features include an economical steel vee groove style blade design that provides unmatched strength and durability, low pressure drop frame design and maintenance free concealed blade linkage for superb air performance, minimal turbulence and noise.



Model 1260

- PREMIUM PERFORMANCE
- EXTRUDED ALUMINUM AIRFOIL BLADE
- CLASS I OR II LEAKAGE @ 250°F OR 350°F
- UL 555S CLASSIFIED SMOKE DAMPER

Models:

- 1280** No Sleeve
- 1281** Type A Sleeve
- 1282** Type B Sleeve Enclosure
- 1283** Type C Sleeve Enclosure



Model 1280

Model Series 1280 Smoke Dampers are the premium choice for applications where building codes require a leakage rated smoke damper as part of a static smoke control or dynamic smoke management system. The design features a smoothly contoured, aerodynamic extruded aluminum airfoil blade with compression type seals, engineered to provide the lowest leakage class available and the lowest pressure drop in the industry! Together with a concealed linkage out of the airstream, the design exhibits ultra-low pressure drop characteristics with minimal turbulence and noise generation. A rugged 16 ga. (1.6) frame with reinforced mitered corners and die-formed corner gussets combine performance with durability. The 1280 Series is qualified for vertical or horizontal installation with airflow in either direction.

QUALIFICATIONS:

- **UL 555S CLASSIFIED SMOKE DAMPER (File # R9492)**
Leakage Class I or II at 250°F or 350°F elevated temperature.
- Meets NFPA 90A, 92, 101 and 105 as well as IBC and NBC (Canada) Building Code requirements.
- City of New York. MEA # 366-03-M.
- California State Fire Marshal: Fire Damper Listing No. 03230-0935:0107.
- Maximum velocity: 2000 fpm @ 4" w.g. (10 m/s @ 1 kPa).

STANDARD CONSTRUCTION:

- Frame:** 5" x 7/8" x 16 ga. (127 x 22 x 1.6) galvanized steel hat channel.
- Blades:** Airfoil type 6063-T5 extruded aluminum on 5 1/2" (140) centers. Parallel action.
- Linkage:** Concealed in frame. 12 ga. (2.7) plated steel.
- Bearings:** 1/2" (13) dia. self-lubricating oilite bronze.
- Axles:** 1/2" (13) dia. plated steel double bolted to blades.
- Jackshaft:** 1/2" (13) dia. plated steel.
- Jamb Seals:** Cambered stainless steel.
- Blade Seals:** Silicone.

Models 1280 and 1281 Sizes (Duct W x H):

Velocity/ Pressure Rating	Elevated Temp. °F	Minimum			Maximum		
		Single Section		Single Section		Multiple Section	
		Vertical/Horizontal	Vertical/Horizontal	Vertical/Horizontal	Vertical/Horizontal		
24	250/350	8" x 8" (203 x 203)	36" x 48" (914 x 1219)	144" x 96" (3658 x 2438), 288" x 48" (7315 x 1219) or 72" x 144" (1829 x 3658).			

Note: Dampers with duct heights less than 8" (203) require a Type 'B' sleeve enclosure (Model 1282). Duct sizes less than 8" (203) in width require a Type 'C' enclosure (Model 1283).

COMMON OPTIONS:

- DTS Damper Test Switch for cycle testing.
- DSDL/DSDN Duct Smoke Detectors.
- MLS-300 Position Indicator Switch Pack.
- Factory fitted sleeves in custom lengths, gauges and transition styles.

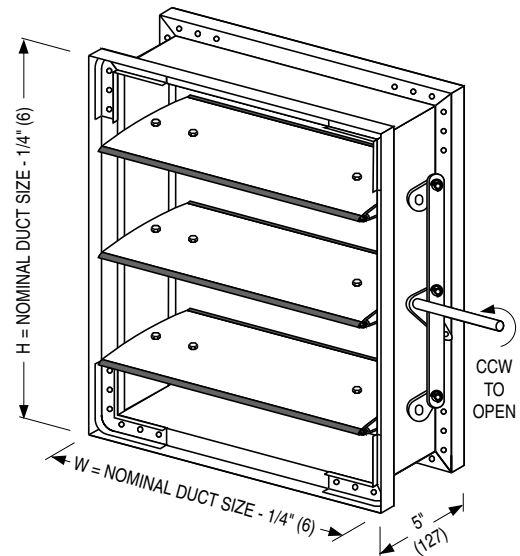

MODEL 1280

(Side Mounting Plate/Sleeve not shown)

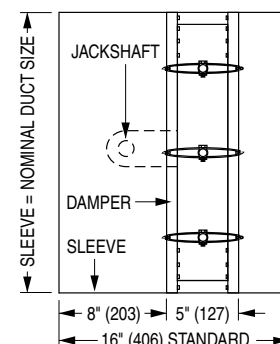

MODEL 1281 WITH TYPE A SLEEVE:

Model 1281 - Standard factory sleeve (caulked to UL requirements) 16" long x 20 ga. (406 x 1.0) (18 ga. [1.3] for dampers over 84" [2134] in width). Available up to 36" (914) dependent upon wall thickness and 10 through 20 ga. (3.5 through 1.0).

SMOKE DAMPERS

DIMENSIONAL DATA:

Model Series 1280 dampers with duct heights less than 8" (203) require a Type 'B' sleeve enclosure (Model 1282). Duct sizes less than 8" (203) in width require a Type 'C' enclosure (Model 1283).

MODEL 1282: TYPE B SLEEVE ENCLOSURE

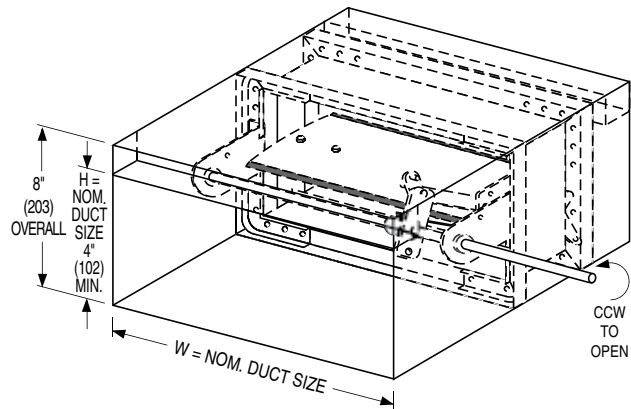
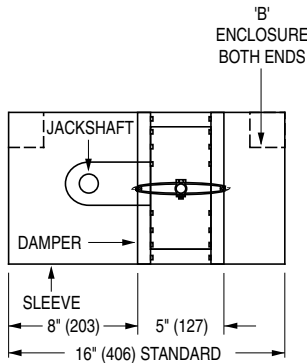

Standard factory sleeve (caulked to UL requirements) 16" long x 20 ga. (406 x 1.0) (18 ga. [1.3] for dampers over 84" [2134] in width). Available up to 36" (914) dependent upon wall thickness and 10 through 20 ga. (3.5 through 1.0).

Wall Thickness	Minimum Sleeve Length
4 (102)	16 (406)
8 (203)	20 (508)
12 (305)	24 (610)
16 (406)	28 (711)

Model 1282 Sizes (Duct W x H):

Velocity/Pressure Rating	Elevated Temp. °F	Minimum		
		Single Section		Multiple Section
		Vertical/Horizontal	Vertical/Horizontal	Vertical/Horizontal
24	250/350	8" x 4" (203 x 102) Overall damper height is 8" (203).	36" x 7 1/2" (914 x 191)	288" x 7 1/2" (7315 x 191)

MODEL 1283: TYPE C SLEEVE ENCLOSURES

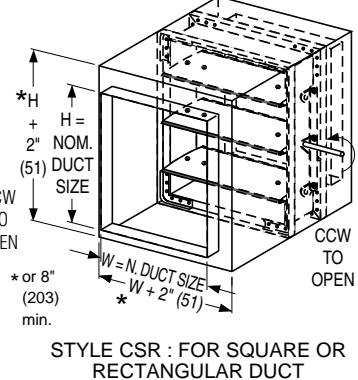
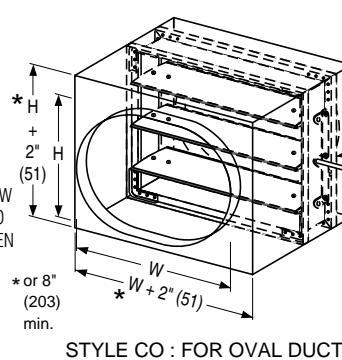
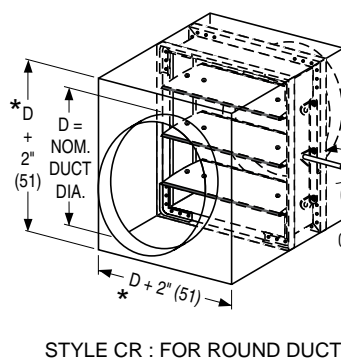
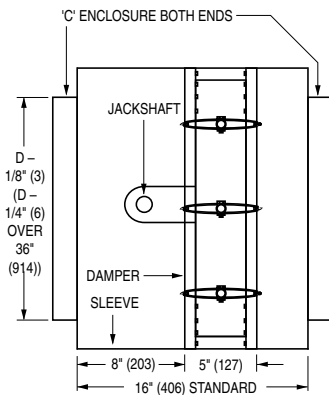

Standard factory sleeve (caulked to UL requirements) 16" long x 20 ga. (406 x 1.0) (18 ga. [1.3] for dampers over 84" [2134] in width). Available up to 36" (914) dependent upon wall thickness and 10 through 20 ga. (3.5 through 1.0).

Wall Thickness	Minimum Sleeve Length
4 (102)	16 (406)
8 (203)	20 (508)
12 (305)	24 (610)
16 (406)	28 (711)

Model 1283 - Round Duct Connection Sizes (Duct Dia.):

Velocity/Pressure Rating	Elevated Temp. °F	Minimum		
		Single Section		Multiple Section
		Vertical/Horizontal	Vertical/Horizontal	Vertical/Horizontal
24	250/350	4" (102) dia. Overall damper size is 8" x 8" (203 x 203) min.	34" (864) dia.	94" (2388) dia.

Model 1283 - Square, Rect. or Oval Duct Connection Sizes (Duct W x H):

Velocity/Pressure Rating	Elevated Temp. °F	Minimum		
		Single Section		Multiple Section
		Vertical/Horizontal	Vertical/Horizontal	Vertical/Horizontal
24	250/350	4" x 4" (102 x 102). Overall damper size is 8" x 8" (203 x 203) min.	34" x 46" (864 x 1168)	142" x 94" (3607 x 2388), 286" x 46" (7264 x 1168) or 70" x 142" (1778 x 3607).

PERFORMANCE DATA:

MODEL SERIES: 1280

LEAKAGE CLASS:

The 1280 Series Smoke Damper has been designed and qualified under UL 555S in order to provide maximum system design flexibility. It is available with a Class I (currently the lowest available) or Class II leakage rating with all damper/actuator assemblies having been tested successfully at an elevated temperature of 250°F (121°C) or 350°F (177°C), depending on actuator, under airflow of 2000 fpm (10 m/s) at 4" w.g. (1 kPa).

Maximum Performance Ratings	
UL 555S Leakage Rating	Class I
Maximum Velocity	2000 fpm (10 m/s)
Maximum Pressure	4 in. w.g. (1 kPa)
Maximum Temperature	350°F (177°C)

PRESSURE DROP:

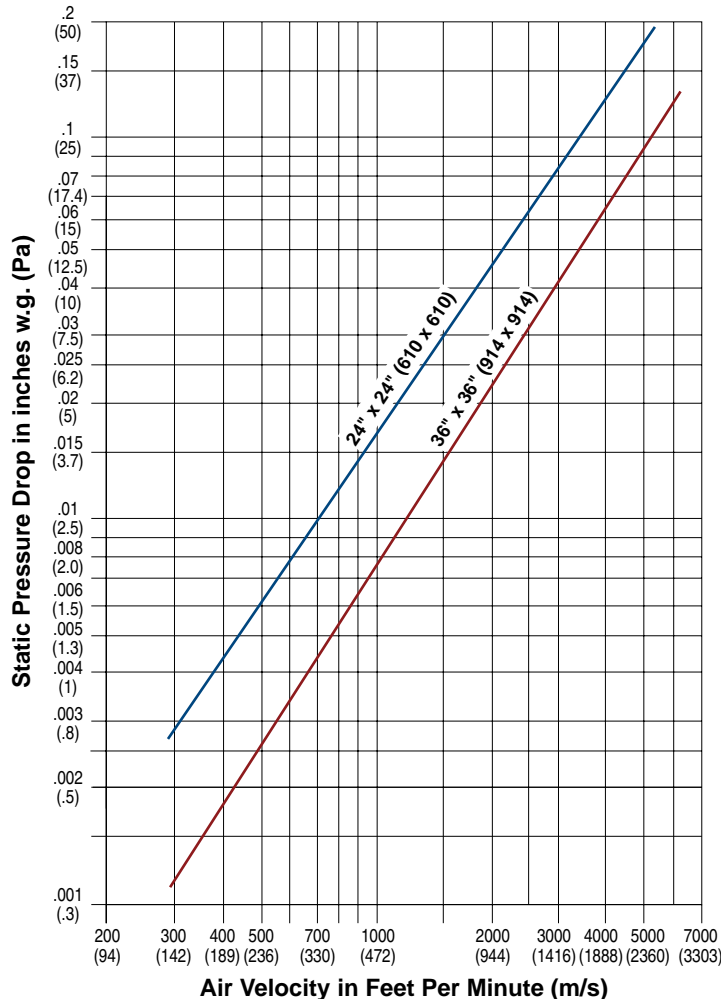

Pressure drop tested per AMCA Standard 500-D, Figure 5.3.
Data corrected to standard air density of 0.075 lbs/ft.³.

HOW TO ORDER

EXTRUDED ALUMINUM AIRFOIL BLADE SMOKE DAMPERS

MODEL SERIES: 1280

EXAMPLE: 1281 - 24X24 - H/V - AUTO - 120 - I - 24 - 250 - BO - SL = 16 - 20G - EXT - RH - CL - HH1 - L8

- 1a. **Models**
1280 Aluminum, Airfoil Blade
- 1b. **Sleeve/Enclosure Style**
(4th Digit)
0 = No Sleeve
1 = Type A Sleeve
2 = Type B Sleeve Enclosure
3 = Type C Sleeve Enclosure
- 2. **Duct Size**
Width x Height
inches (mm's)
- 3. **Mounting**
H/V Horizontal/Vertical (default)
- 4. **Actuator Selected By**
AUTO Least Cost (Auto-Select) (default)
HON Honeywell
SIE Siemens
- 5. **Power Requirement**
120 120 VAC (default)
230 230 VAC
24 24 VAC
25 25 psi Pneumatic
- 6. **Leakage Rating**
I Class I (default)
II Class II
- 7. **Max. Velocity / Pressure Rating**
24 2000 fpm @ 4" w.g. (default)
- 8. **Elevated Temperature**
250 250°F (default)
350 350°F
- 9. **Bearings**
BO Oilite Bronze (default)
BS Stainless Steel
- 10. **Duct Smoke Detector**
— None (default)
DSDL Low-Flow, factory mounted
DSDN No-Flow, factory mounted

- 11a. **Side Mounting Plate**
(No Sleeve models only)
SMP Side Mounting Plate
- 11b. **Sleeve Length**
SL = Specify
16" (406) standard (default)
12" – 28" (305 – 711)
- 12. **Sleeve Gauge**
20G 20 Ga. standard (default)
18G 18 Ga.
16G 16 Ga.
14G 14 Ga.
10G 10 Ga.
- 13. **Transition**
(Sleeve Type C models only)
CR Round
CO Oval
CSR Square/Rectangular
- 14. **Actuator Mounting**
EXT External (default)
INT Internal
- 15. **Actuator Location**
RH Right hand (default)
LH Left hand
MH Multi-hand
- 16. **Actuator Fail Position**
CL Close (default)
- 17. **Actuator Models**
Electric:
HM1 MS4109F 120VAC
HM2 MS8109F 24VAC
HM3 MS4609F 230VAC
HH1 MS4120F 120VAC
HH2 MS8120F 24VAC
HH3 MS4620F 230VAC
Pneumatic:
296 331-2961
- 18. **Damper Location**
L8 8" (203) from sleeve end (default)
LX Other (specify)
8" – 16" (203 – 406)
- 19. **Extruded Aluminum Frame**
— None (default)
EAF Extruded Aluminum Frame

OPTIONS & ACCESSORIES:

- 20. **Position Indicator**
— None (default)
300 MLS-300 (4-wire)
- 21. **EP Switch**
— None (default)
EP1 120 VAC
EP2 24 VAC
- 22. **TDF Flange**
— None (default)
TDF1 One End
TDF2 Both Ends
- 23. **Damper Test Switch**
— None (default)
DTS Damper Test Switch

Notes:

- 1. Not all variants and options are available on all models. Refer to individual model for selection availability.
- 2. One MLS-300 required per damper assembly.
- 3. EP (electric-pneumatic) switch optional accessory is applicable only to pneumatic actuators and is shipped loose.

F SMOKE DAMPERS

HOW TO SPECIFY

EXTRUDED ALUMINUM AIRFOIL BLADE SMOKE DAMPERS

MODEL SERIES: 1280

SUGGESTED SPECIFICATION:

Provide and install, as shown on plans and/or schedules, Smoke Dampers as manufactured by Nailor Industries, Inc. which meet or exceed the following criteria: Smoke dampers shall meet the requirements of NFPA 90A, 92, 101 and 105 and shall be classified as a **(specifier select class)** Class I **or** Class II Leakage Rated Smoke Damper under UL 555S at an elevated temperature of **(specifier select temperature)** 250°F (121°C) **or** 350°F (177°C) and each damper shall bear a UL label verifying same. Dampers shall be suitable for use in dynamic or static smoke control systems. Dampers shall have been operation tested by UL to a minimum velocity/pressure rating of 2000 fpm @ 4" w.g. (10 m/s @ 1 kPa).

Frame shall be constructed of 16 ga. (1.6) galvanized steel hat channel with mitered corners reinforced with die-formed corner gussets for strength. Blades shall be of Type 6063-T5 extruded aluminum airfoil design on maximum 6" (152) centers with integral structural reinforcing tube running full length of each blade. Blade axles shall be 1/2" (13) dia. plated steel, double bolted at each end of blade to provide positive locking connection. Hex, square friction-fit or press-fit axles are not acceptable. Bearings shall be self-lubricating oilite bronze type. Blade linkage shall be zero-maintenance, concealed in frame, out of airstream. Jamb seals shall be compression type cambered stainless steel. Blade seals shall be silicone, mechanically locked in extruded blade slots. Adhesive or clip-on type blade seals are not acceptable. Appropriate **(specifier select)** externally **or** internally mounted **(specifier select type)** electrical **or** pneumatic actuators shall be installed by the damper manufacturer in the factory. Actuators shall incorporate an OEM internal spring return mechanism, external after-market spring mechanisms are not acceptable. Damper and actuator assembly shall be factory cycled a minimum of 3 times to ensure correct operation.

Damper manufacturer shall submit pressure drop data to be based on tests in accordance with AMCA Standard 500-D). Standard of acceptance shall be Nailor Industries, Inc. Model Series 1280.

Options and Accessories

Nailor smoke dampers are tested by and listed with Underwriters Laboratories Inc. and are manufactured within UL procedural requirements.

SIDE PLATES/SLEEVES FOR ACTUATOR MOUNTING:

OPTION CODE **SMP**
SIDE ACTUATOR MOUNTING PLATE

Nailor's **SMP**, Side Mounting Plate, provides a practical and cost effective method of factory installing an actuator onto Model Series 1210, 1260, and 1280 smoke dampers. UL 555S, Standard for Smoke Dampers requires actuators to be factory mounted securely in position. This is to help ensure that the damper/actuator assembly functions properly and eliminates possible job site installation errors. Nailor's SMP option allows the damper/actuator assembly to be conveniently mounted in duct opening for fast, worry-free installation.

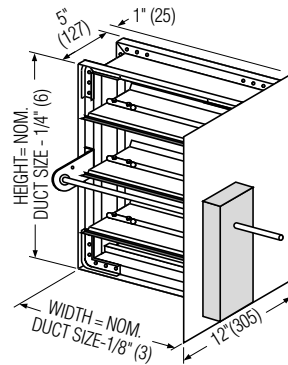

SIDE ACTUATOR MOUNTING PLATE FOR JACKSHAFT DRIVE

TYPE A SLEEVES
MODELS 1211, 1261, 1281

As an alternative to using a side mounting plate to mount an actuator onto a Series 1210, 1260 or 1280 smoke damper, Nailor smoke dampers can be provided in a full factory-fitted sleeve, factory caulked to UL specifications between the damper frame and sleeve. This eliminates on site worries about proper damper mounting in the duct and provides for quick and convenient job site installations. Standard Type A sleeve is 16" (406) long x 20 ga. (1.0) (18 ga. for dampers over 84" (2134) in width). Non-standard lengths and gauges are available to suit specific applications. See chart for specific sleeved model numbers.

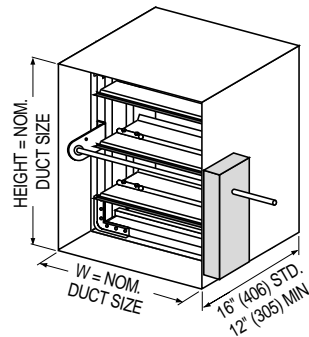

TYPE A SLEEVE FOR JACKSHAFT DRIVE

The following indicates model numbers to order for smoke dampers with factory fitted Type A sleeves:

Standard Model #	With Type A Sleeve
1210 →	Model 1211
1260 →	Model 1261
1280 →	Model 1281

POSITION INDICATORS:

OPTION CODE 300
MLS-300 POSITION INDICATOR SWITCH PACK

The **MLS-300 Series Position Indicator Switch Pack** is generally utilized to indicate open and closed position of the damper blades. It incorporates two SPDT switches that may be used to operate signal lamps or to provide a start/stop circuit for remote fans or to signal alarms.

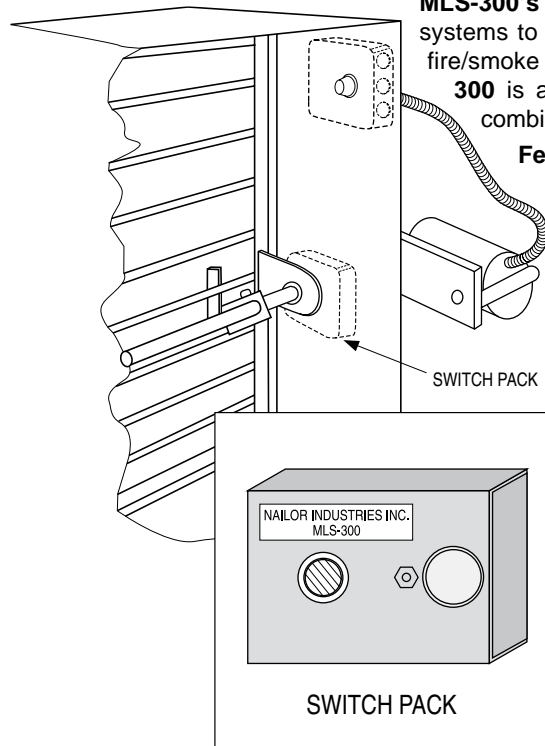

MLS-300's are used in active smoke control management systems to positively indicate the status of all combination fire/smoke and smoke dampers in the building. The **MLS-300** is available only as a factory installed option on combination fire/smoke and smoke dampers.

Features:

- Operates as a function of the damper blade position.
- Provides remote indication of damper blade position.
- Provides the ability to remotely control ON/OFF fan stations.
- Provides the ability to remotely signal alarms.

Built-in Actuator Switch Packs

Many of the newer application specific actuators designed for use on fire/smoke dampers feature “add-on” component position indicator switches manufactured and UL tested by the actuator manufacturer. Honeywell MS4109F/MS8109F actuators are examples.

Some actuator models have variants with position indicator switches built right in to the actuator. Honeywell MS4120F/MS8120F and Belimo FSNF24S/FSNF120S actuators are examples.

When ordered with the MLS-300 Position Indicator Switch Pack, Nailor combination fire/smoke and smoke dampers that utilize these actuators will usually be supplied with the actuator mounted switch pack, factory installed as required by UL.

POSITION INDICATORS:

MLS-300N (NAILOR) SWITCH DETAILS

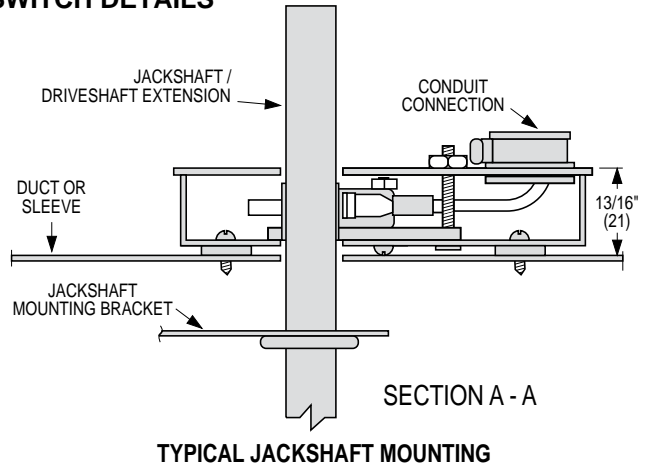
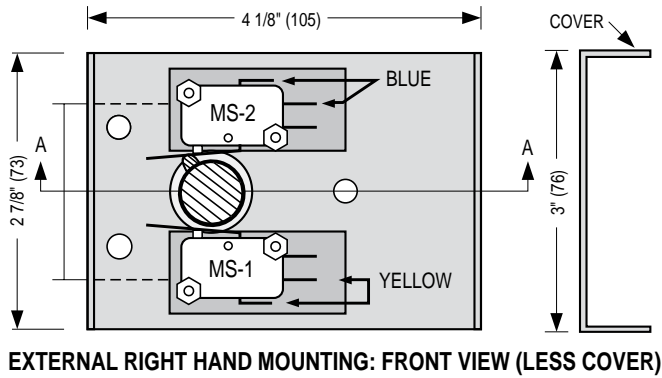

Position Indicator Microswitch Data:
 Switch Type: Single Pole double throw (2)
 15 Amps, 1/3 HP, 125, 250 Vac or 24 Vdc.
 1/2 Amp, 125 Vdc. 1/4 Amp, 250 Vdc.

Standard Mounting:
MS1 is damper open signal.
MS2 is damper closed signal.

Non-Standard Mounting:
Important: Installer must double check continuity of MS1 and MS2 before wiring to determine which switch signals the damper's open or closed position.

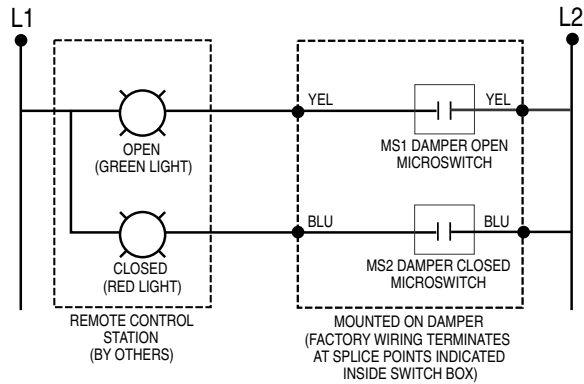

FLANGED SLEEVE

OPTION CODES

- TDF FLANGE
- TDF2 BOTH ENDS
- TDF1 ONE END



TDF (by Engle) and **TDC** (by Lockformer) proprietary flange systems are available as an option on all model smoke dampers fitted with a factory Type A sleeve of 22 or 20 gauge thickness. The flange system allows for fast, simple duct connections in the field. For Option **TDF1** the sleeve is factory flanged on one end only.

For Option **TDF2** the sleeve is factory flanged on both ends. Note that the maximum wall/floor opening size permitted by UL, relative to the damper size,

may not physically allow the flange to fit through the opening. Consultation and co-ordination with the wall/floor contractor is recommended. **TDF1**, flange on one end only, will permit the non-flanged end of the sleeve to fit through the opening. Specify which end of sleeve to be flanged in relation to the jackshaft.

F

SMOKE DAMPERS

DAMPER TEST SWITCH

OPTION CODE DTS
PUSH BUTTON TEST SWITCH

The DTS (Damper Test Switch) is an optional "momentary" push button test switch available on all Nailor smoke and combination fire/smoke dampers. The DTS provides the ability to "cycle test" the damper by pushing and holding down the button until the damper has cycled and closure has been visually verified, either by inspecting the damper through the access door or by confirmation at a remote control panel when equipped with the optional MLS-300 position indicator.

The DTS is mounted right on the damper and enables a single maintenance person to test and cycle the damper, eliminating the need for help from another person in the control room.

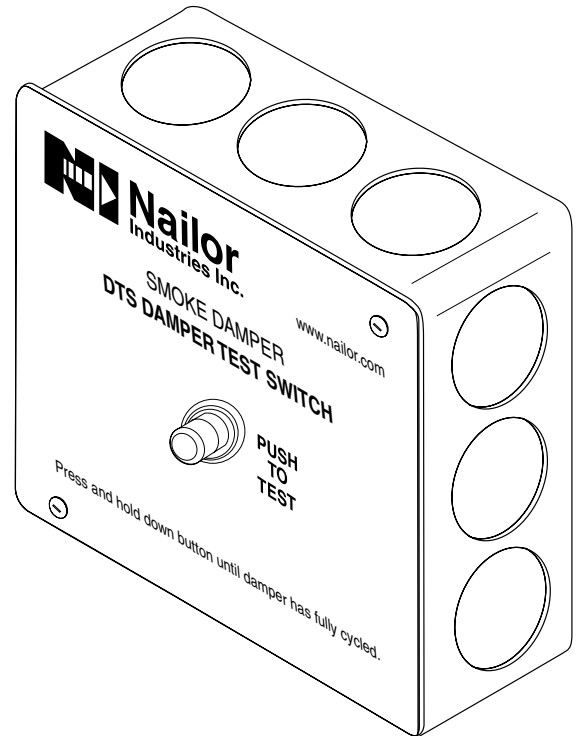

DTS Damper Test Switch

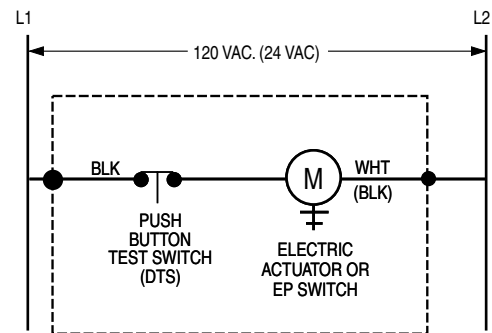

MOUNTED ON DAMPER (FACTORY WIRING TERMINATES AT SPLICE POINTS INDICATED INSIDE 4" x 4" ELECTRICAL BOX)

Figure 1. DTS Damper Test Switch

F
SMOKE DAMPERS

ELECTRO-PNEUMATIC SWITCHES:

OPTION CODES **EP1** AND **EP2**
 EP1 120 VAC E/P SWITCH
 EP2 24 VAC E/P SWITCH



Nailor Options **EP1** and **EP2** electro-pneumatic switches are electrically operated, two-position 3-way air valves. They are used to interlock an electrical smoke or fire alarm system with a pneumatic damper actuator. The **EP1 (120 VAC)** and **EP2 (24 VAC)** valves are utilized to alternately apply pressure to, and exhaust pressure from a pneumatic damper actuator by an electrical input that energizes or de-energizes the solenoid of the switch. Barb type pneumatic piping connections are sized for 1/4" (6) O.D. Polyethylene tubing. Units are UL and CSA approved and may be mounted in any position.

EP1 Siemens 265-1008 120 V/60 Hz

EP2 Siemens 265-1007 24 VAC

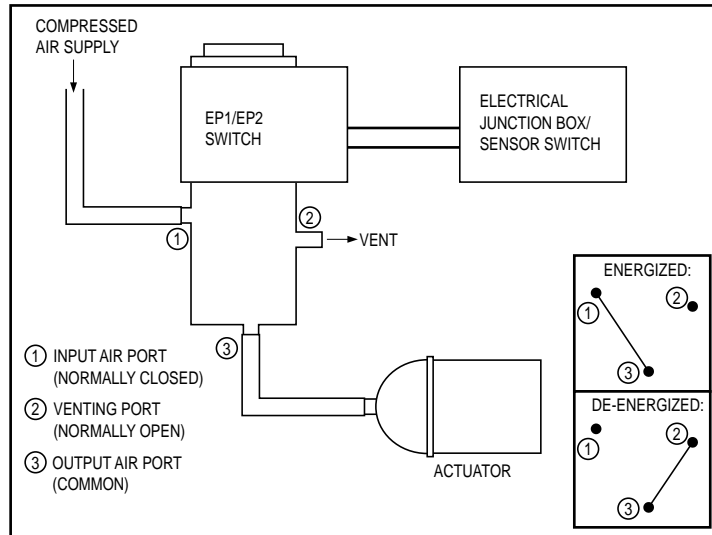

OPERATION:

Input air is connected to port 1 (normally closed) and the output to the actuator is connected to port 3 (common). When the solenoid is energized port 1 connects to port 3 allowing the actuator to be controlled by input air, usually holding the damper in open position. When the solenoid is de-energized, port 2 (normally open) is connected to port 3, exhausting the air from the actuator allowing it to return to its normal fail position (fail open or fail closed).

Note:

E.P. Switches ship loose when ordered with Smoke Dampers and require field installation.

DUCT SMOKE DETECTORS:

OPTION CODE DSDN
 DSD-NF NO-FLOW
 DUCT SMOKE DETECTOR

APPLICATION:

Nailor Model DSD-NF duct smoke detector (no-flow) can be utilized with Nailor UL555S Classified smoke dampers to detect the presence of smoke within HVAC ductwork, whether or not there is airflow, and close the damper to prevent the smoke from spreading. As most fatalities resulting from fires can be attributed to the effects of toxic smoke, detecting and controlling the smoke from spreading within the HVAC system is vital to preventing injury as well as limiting property damage, including damage to the HVAC system itself. Refer to NFPA Standards 72, 90A and 92 to determine when and where duct smoke detectors are required.

The DSD-NF detector features a low-profile design for optimum pressure drop and will operate with airflow in either direction. It can be factory installed to top of sleeve (side mounting optional) on Nailor Model Series 1210, 1260 and 1280 smoke dampers.

OPERATION:

Upon detection of smoke, the smoke detector causes the damper to close by cutting off power to the actuator. The actuator return spring forces the damper closed. The detector can be reset only by a momentary power interruption. The standard model DSD-NF detector and smoke damper combination is designed simply to close the damper upon detection of smoke. For applications requiring the detector to be wired into a fire fighters' smoke-control station (FSCS), contact Nailor.

DSD-NF STANDARD SPECIFICATION:

- Model:** System Sensor 2151 Low-Profile.
- Sensor Type:** Photoelectronic.
- Dimensions:** 6.1" (155) dia. flanged base.
- Weight:** 3.6 oz. (104 g).
- Airflow Velocity Range:** 0 to 3000 fpm (0 to 15.24 m/s).
- Operating Temperature Range:** 32°F to 120°F (0°C to 49°C).
- Operating Humidity Range:** 10% to 93% Relative Humidity Non-Condensing.
- Sensitivity:** 3% ± .7%/ft
- Voltage:** 120 VAC or 24 VAC/DC.
- Latching Alarm:** Reset by momentary power interruption.

Contact Nailor for minimum damper size and sleeve length for your specific application. See page C13 for general damper size, sleeve length and damper position guidelines.

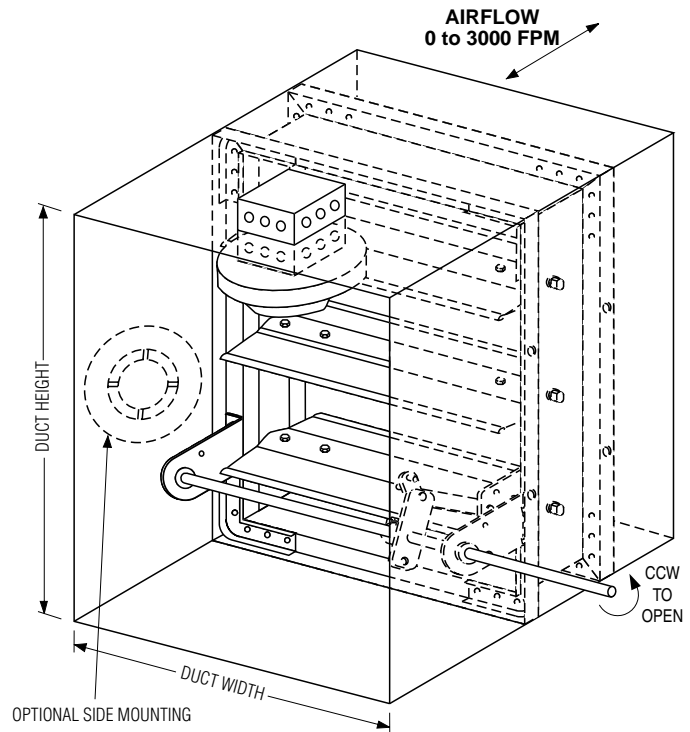

NOTES:

1. Factory mounted smoke detectors will be factory wired to actuator(s) (or E.P. switch) and heat sensor(s), as applicable, into a 4" x 4" (102 x 102) common junction box in order to provide a single point wiring connection in the field.

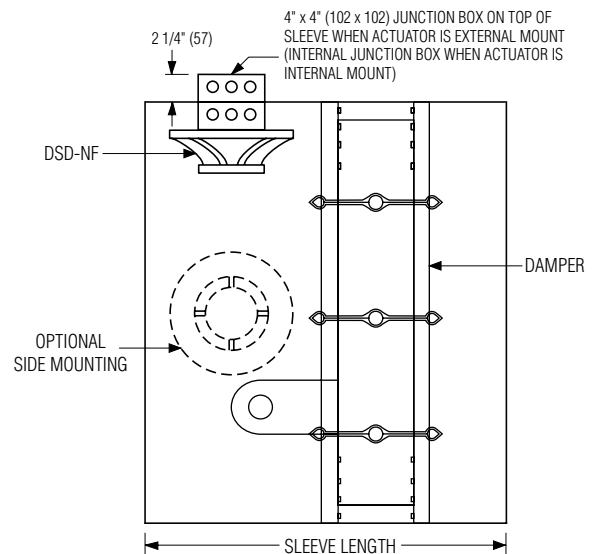

F
SMOKE DAMPERS

DUCT SMOKE DETECTORS:

OPTION CODE DSDL
 DSD-LF LOW-FLOW
 DUCT SMOKE DETECTOR

APPLICATION:

Nailor Model DSD-LF duct smoke detector (low-flow) can be utilized with Nailor UL555S Classified smoke dampers to detect the presence of smoke within HVAC ductwork and close the damper to prevent the smoke from spreading. As most fatalities resulting from fires can be attributed to the effects of toxic smoke, detecting and controlling the smoke from spreading within the HVAC system is vital to preventing injury as well as limiting property damage, including damage to the HVAC system itself. Refer to NFPA Standards 72, 90A and 92A to determine when and where duct smoke detectors are required. The DSD-NF detector can be factory installed to side of sleeve on Nailor Model Series 1210, 1260 and 1280 smoke dampers.

A minimum airflow velocity of 100 fpm (0.5 m/s) is required for Model DSD-LF.

OPERATION:

Upon detection of smoke, the smoke detector causes the damper to close by cutting off power to the actuator. The actuator return spring forces the damper closed. The detector can be reset only by a momentary power interruption. The standard model DSD-LF detector and smoke damper combination is designed simply to close the damper upon detection of smoke. For applications requiring the detector to be wired into a fire fighters' smoke-control station (FSCS), contact Nailor.

DSD-LF STANDARD SPECIFICATION:

Model: System Sensor D4120.

Sensor Type: Photoelectric.

Dimensions: (Rectangular) 14.38" (365) Length, 5" (127) Width, 2.5" (64) Depth.

Weight: 2.5 lbs. (1.14 kg.).

Airflow Velocity Range: 100 to 4000 fpm (0.5 to 20.3 m/s).

Operating Temperature Range: -4°F to 158°F (-20°C to 70°C).

Operating Humidity Range: 0% to 95% Relative Humidity Non-Condensing.

Voltage: 24 VAC/DC or 120 VAC.

Contact Nailor for minimum damper size and sleeve length for your specific application. See page C13 for general damper size, sleeve length and damper position guidelines.

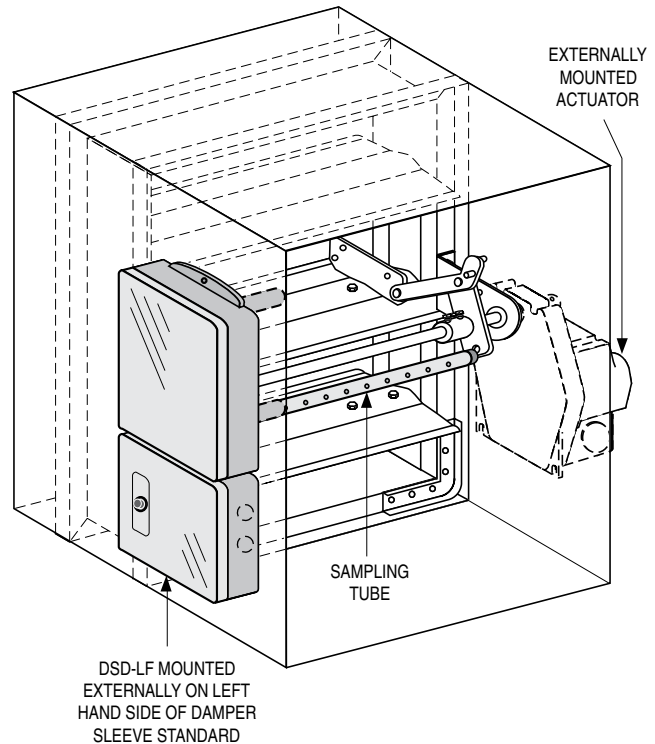

NOTES:

1. Smoke detector is factory mounted externally on left side of sleeve (opposite side of sleeve to the actuator) and will be mounted horizontally on dampers under 20" (508) in height and mounted vertically on dampers 20" (508) in height and over. See orientation details below.
2. Factory mounted smoke detectors will be factory wired to actuator(s) (or E.P. switch) and heat sensor(s), as applicable, into a 4" x 4" (102 x 102) common junction box in order to provide a single point wiring connection in the field.

