

GENERAL PRODUCT OVERVIEW

Retrofit Terminal Units

- Convert Constant Air Volume Systems to Variable Air Volume.
 - Convert Constant Volume Dual Duct Systems to Variable Air Volume.
 - Convert Multizone Systems to Variable Air Volume.
 - Convert Mechanical Constant Volume Regulators to Low Pressure Digital, Analog Electronic or Pneumatic Controls.
- Nailor manufactures a range of standard and custom design retrofit terminal units for all applications.

Round Duct External Retrofit Terminal Unit

Convert existing constant volume systems or old "system powered" mechanical regulator terminals to energy efficient variable volume operation.

- Available in 10 sizes to suit and install simply in round ductwork. 0 – 4050 cfm (0 – 1911 l/s).
- Various configurations custom fabricated to suit individual applications.
- Pressure dependent or independent airflow control.
- Diamond Flow multi-point averaging flow sensor on pressure independent models.
- Digital, electric, analog electronic or pneumatic control.

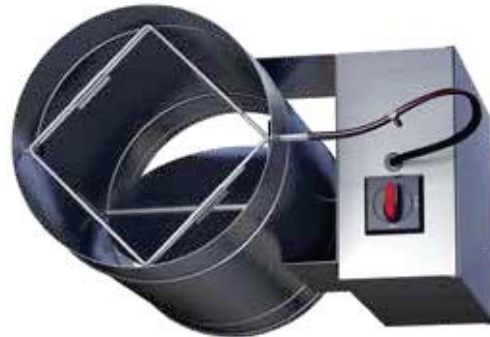

Model 36VRR

Model 36VRR

See page D5



Model 36VRS

Rectangular Slide-in Retrofit Terminal Unit

Convert existing constant volume systems to energy efficient variable volume operation.

- Available in 15 valve sizes to handle a large range of air volumes. 0 – 15000 cfm (0 – 7079 l/s).
- Custom fabricated to suit any duct size from 5" x 5" (127 x 127) up to 52" x 26" (1321 x 660).
- Diamond Flow multi-point averaging sensor.
- Pressure independent airflow control.
- Digital, analog electronic or pneumatic control.

Model 36VRS

See Page D10

Internal Retrofit Terminal Units

Designed to replace the mechanical regulators in old system powered terminal units in order to substantially lower the operational static pressure requirement. The air valves include a damper, flow sensor and actuator and make use of state-of-the-art controls in order to reduce operating cost.

- Custom built on a specific project basis.
- Variable or constant volume pressure independent airflow control.
- Diamond Flow multi-point averaging flow sensor.
- Models available to retrofit most brand name mechanical regulator design terminal units.
- Digital, analog electronic or pneumatic control.

Model 36VRTR

Contact your Nailor Sales Rep.

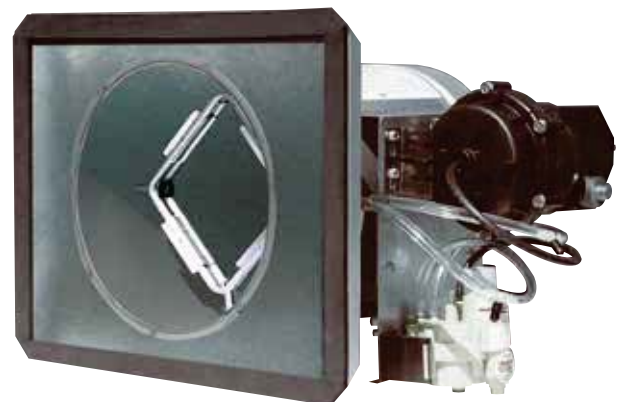

Model 36VRTR

Some Typical Applications for the Model Series 36VR Retrofit Terminal Units

Dual Duct System

Hot and cold air from the central station is distributed through the existing supply ducts and terminals. The **Series 36VR Retrofit Terminals** will convert the constant volume system to variable air volume pressure independent operation.

Remove the mechanical constant volume regulator from the existing terminal, while a **Model 36VRS** is installed in the discharge box or duct. A direct acting thermostat controls both the **36VRS** unit and the modulating tandem damper in the existing box. On a rise in room temperature, the **36VRS** reduces the hot airflow. At the minimum setting, the damper in the existing terminal begins to modulate, and mixing occurs. A further temperature rise increases the cold airflow to the maximum.

The fan capacity may be reduced down since the total air volume is reduced.

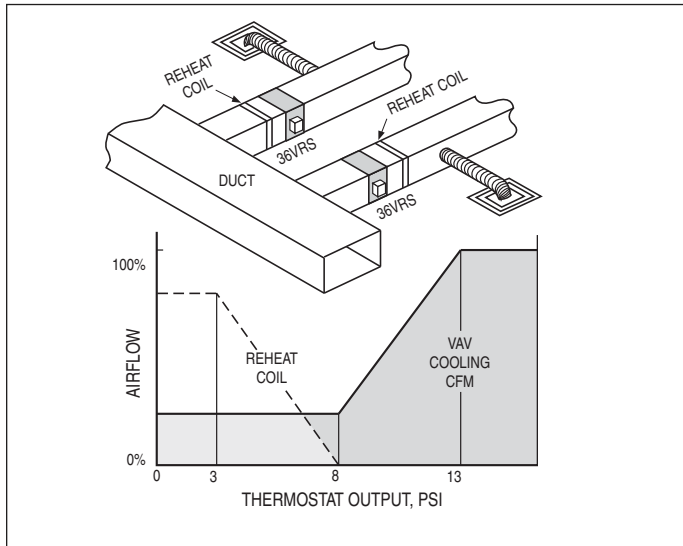
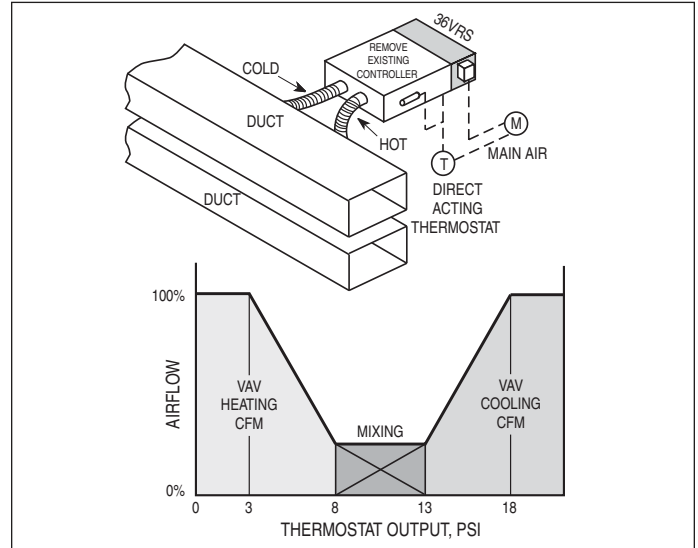

Constant Volume Reheat System

Cold air from the central station is distributed through the existing main trunk and branch ducts. The **Model 36VRS Retrofit Terminals** will convert the constant volume system to pressure independent variable air volume operation.

Each **36VRS** terminal is signaled by a direct acting thermostat. The pressure independent minimum airflow is set at a thermostat output pressure of 8 psi or less, while the maximum is set at 13 psi or greater.

The existing reheat coil in each zone is actuated on a fall in room temperature, as the thermostat output decreases from 8 to 3 psi.

The fan capacity must be reduced since the total air volume is reduced.

Multizone System

Hot or cold air from the central station multizone air handler is distributed through the existing zone system. The **Series 36VR Retrofit Terminals** will convert the multizone system to variable air volume operation.

The zone dampers in the central station air handler are made with two-position actuators; each zone is fully open, either heating or cooling. There is no mixing. (Controls may be selected for an outdoor thermostat, a manual selector or changeover signal.)

A dual function thermostat in each zone is direct acting for cooling, reverse acting for heating. In response to the room temperature, the thermostat resets the velocity controller for pressure independent control of the **Series 36VR**.

The fan capacity may be reduced since the total air volume is reduced.

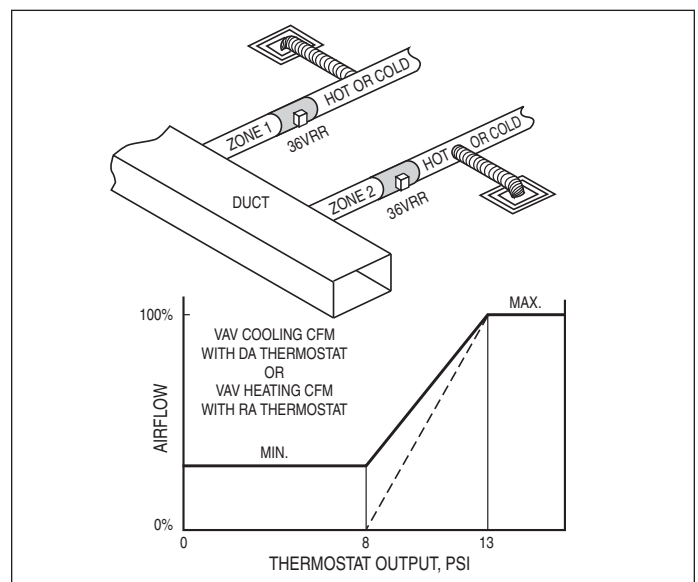

ROUND EXTERNAL DUCT RETROFIT TERMINAL UNITS

MODEL 36VRR

- VARIABLE AIR VOLUME
CONVERSION

Model 36VRR is designed for round ductwork retrofit application. Terminals are available in 10 sizes and are nominally undersized to ensure a good fit.

Easy, low-cost installation into existing ductwork. The installer cuts out a section in the round duct and replaces the duct section with the conversion unit.

STANDARD FEATURES:

- Casing 22 ga. (0.86), corrosion-resistant steel with stiffening beads. Sizes 14 and 16 are 20 ga. (1.0).
- Blade: Two layers of 22 ga. (0.86), corrosion-resistant steel laminated together (equivalent to 16 gauge) with a cross-linked polyurethane peripheral gasket for tight shut-off, 90° rotation, CW to close. Damper leakage is less than 1% of terminal rated airflow 3" w.g. (750 Pa) as tested in accordance with ANSI/ASHRAE Standard 130.
- Bearing: Self-lubricating oilite bronze and less than 2% at 6" w.g. (1500 Pa).
- Drive Shaft/Axles: 1/2" (13) diameter plated steel, double-bolted to blades. Indicator mark on the end of the shaft to show damper position.
- Full electrical controls enclosure for factory mounted DDC and analog electronic controls.

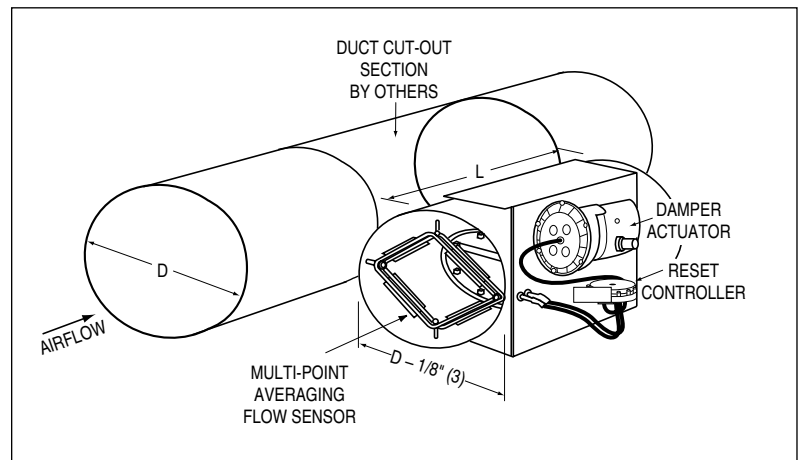

- Multi-point averaging 'Diamond Flow' sensor. Aluminum construction. Gauge taps are provided for field balancing when controls are factory mounted.
- Right-hand control location is standard (as shown). Left-hand is optional.

Options:

- FMI Removable Flow Sensor
- Available in Type 304 and 316 stainless steel construction for laboratory/fume hood exhaust applications.
- Controls enclosure for field mounted controls.
- 24 volt control transformer.
- Toggle disconnect switch.
- Pneumatic or Analog Electronic Pressure Independent controls by Nailor. Factory mounted and calibrated.
- Digital controls by BMS Contractor. Factory mounted by Nailor.

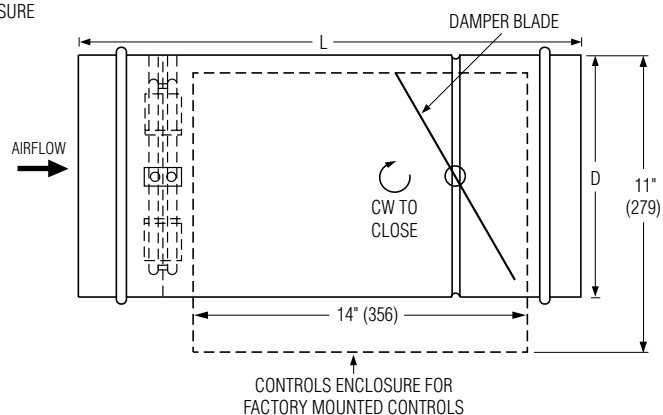
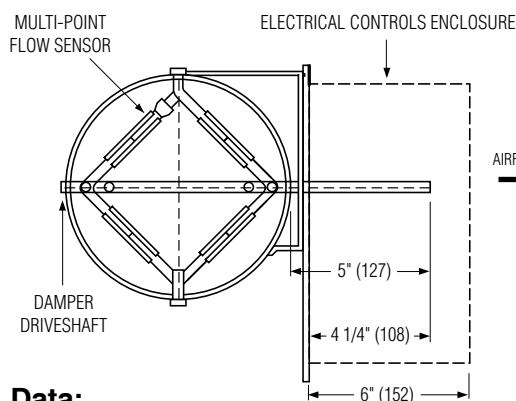

Dimensional Data:

Unit Size	D	L
4	3 7/8 (98)	18 (457)
5	4 7/8 (124)	18 (457)
6	5 7/8 (149)	18 (457)
7	6 7/8 (157)	18 (457)
8	7 7/8 (200)	18 (457)
9	8 7/8 (225)	20 (508)
10	9 7/8 (251)	20 (508)
12	11 7/8 (302)	20 (508)
14	13 7/8 (352)	22 (559)
16	15 7/8 (403)	22 (559)

Recommended Airflow Ranges For Model 36VRR Round Retrofit Terminal Units

The recommended airflow ranges below are for Round Duct Retrofit Terminal Units with pressure independent controls and are presented as ranges for total and controller specific minimum and maximum airflow. Airflow ranges are based upon maintaining reasonable sound levels and controller limits using Nailor's Diamond Flow Sensor as the airflow measuring device. For a given unit size, the minimum, auxiliary minimum (where applicable) and the maximum flow setting must be within the range limits to ensure pressure independent operation, accuracy and repeatability.

Minimum airflow limits are based upon .02" w.g. (5 Pa) differential pressure signal from Diamond Flow Sensor on analog/digital controls and .03" (7.5) for pneumatic controllers. This is a realistic low limit for many transducers used in the digital controls industry. Check with your controls supplier for minimum limits. Setting airflow minimums lower, may cause hunting and failure to meet minimum ventilation requirements. Factory settings will therefore not be made outside these ranges. A minimum setting of zero (shut-off) is also available. Where an auxiliary setting is specified, the value must be greater than the minimum setting.

The high end of the tabulated Total Airflow Range on pneumatic and analog electronic controls represents the Diamond Flow Sensor's differential pressure reading at 1" w.g. (250 Pa). The high end airflow range for digital controls is represented by the indicated transducer differential pressure.



Model 36VRR

ASHRAE 130 "Performance Rating of Air Terminals" is the method of test for the certification program. The "standard rating condition" (certification rating point) airflow volumes for each terminal unit primary valve size are tabulated below per AHRI Standard 880. These air volumes equate to an approximate inlet velocity of 2000 fpm (10.2 m/s).

When digital or other controls are mounted by Nailor, but supplied by others, these values are guidelines only, based upon experience with the majority of controls currently available. Controls supplied by others for factory mounting are configured and calibrated in the field. Airflow settings on pneumatic and analog controls supplied by Nailor are factory preset when provided.

Imperial Units, Cubic Feet per Minute

Unit Size	Inlet Type	Total Airflow Range, cfm	Airflow at 2000 fpm Inlet Velocity (nom.), cfm	Range of Minimum and Maximum Settings, cfm							
				Pneumatic 3000 Controller		Analog Electronic Controls		Digital Controls			
				Transducer Differential Pressure ("w.g.)							
				Min.	Max.	Min.	Max.	Min.	Max.		
4	Round	0 – 225	150	30	180	25	180	25	180	200	225
5		0 – 400	250	55	325	45	325	45	325	350	400
6		0 – 550	400	80	450	65	450	65	450	500	550
7		0 – 800	550	115	650	95	650	95	650	725	800
8		0 – 1100	700	155	900	125	900	125	900	1000	1100
9		0 – 1400	900	200	1150	165	1150	165	1150	1285	1400
10		0 – 1840	1100	260	1500	215	1500	215	1500	1675	1840
12		0 – 2500	1600	350	2050	290	2050	290	2050	2290	2500
14		0 – 3370	2100	475	2750	390	2750	390	2750	3075	3370
16		0 – 4525	2800	640	3700	520	3700	520	3700	4140	4525

Metric Units, Liters per Second

Unit Size	Inlet Type	Total Airflow Range, l/s	Airflow at 10.2 m/s Inlet Velocity (nom.), l/s	Range of Minimum and Maximum Settings, l/s							
				Pneumatic 3000 Controller		Analog Electronic Controls		Digital Controls			
				Transducer Differential Pressure (Pa)							
				Min.	Max.	Min.	Max.	Min.	Max.		
4	Round	0 – 106	71	14	85	12	85	12	85	94	106
5		0 – 189	118	26	153	21	153	21	170	165	189
6		0 – 260	189	38	212	31	212	31	212	236	260
7		0 – 378	260	54	307	45	307	45	342	307	378
8		0 – 579	330	73	425	59	425	59	472	425	579
9		0 – 661	425	94	543	78	543	78	606	495	661
10		0 – 868	519	123	708	101	708	101	790	637	868
12		0 – 1081	755	165	967	137	967	137	1081	1015	1081
14		0 – 1590	991	224	1298	184	1298	184	1451	1444	1590
16		0 – 2135	1321	302	1746	245	1746	245	1954	1911	2135

RETROFIT TERMINAL UNITS

Performance Data • NC Level Application Guide

Model 36VRR

Inlet Size	Airflow		Min. inlet Δ Ps		NC Levels @ Inlet Pressure (Δ Ps) shown							
					DISCHARGE				RADIATED			
					0.5" w.g. (125 Pa)	1.0" w.g. (250 Pa)	1.5" w.g. (375 Pa)	3.0" w.g. (750 Pa)	0.5" w.g. (125 Pa)	1.0" w.g. (250 Pa)	1.5" w.g. (375 Pa)	3.0" w.g. (750 Pa)
cfm	l/s	"w.g.	Pa									
4	225	106	0.25	62	30	35	39	44	-	21	24	30
	200	94	0.20	50	28	34	38	43	-	-	-	22
	150	71	0.10	25	23	29	33	38	-	-	-	-
	100	47	0.05	12	-	23	26	31	-	-	-	-
5	350	165	0.32	80	26	33	34	41	-	26	26	33
	300	142	0.23	57	24	30	34	39	-	21	23	30
	200	94	0.11	27	20	28	30	38	-	-	-	20
	100	47	0.03	7	-	-	21	28	-	-	-	-
6	450	212	0.22	55	26	31	35	40	20	24	28	32
	400	189	0.18	45	24	30	33	38	-	22	24	30
	300	142	0.10	25	20	25	29	34	-	-	-	23
	200	94	0.04	10	-	23	26	31	-	-	-	-
7	650	307	0.21	52	-	20	24	30	-	26	28	33
	550	260	0.14	35	-	-	20	28	-	22	24	28
	450	212	0.10	25	-	-	-	23	-	-	-	25
	350	165	0.06	15	-	-	-	-	-	-	-	-
8	800	378	0.17	42	23	28	31	38	-	26	26	33
	700	330	0.13	32	23	29	31	38	-	24	24	28
	600	283	0.10	25	21	26	30	35	-	-	21	26
	400	189	0.04	10	-	21	25	30	-	-	-	-
9	1050	496	0.17	42	24	29	33	39	-	25	29	35
	850	401	0.11	27	20	23	29	36	-	21	24	32
	650	307	0.07	17	-	25	29	35	-	-	-	26
	450	212	0.03	7	-	-	24	29	-	-	-	21
10	1350	637	0.16	40	24	30	34	40	21	28	31	36
	1150	543	0.12	30	21	28	31	35	-	24	28	33
	950	448	0.09	22	-	25	29	35	-	20	23	30
	750	354	0.05	12	-	21	24	31	-	-	-	24
12	2100	991	0.19	47	25	33	36	43	29	33	36	40
	1700	802	0.12	30	23	29	33	39	23	29	31	35
	1300	614	0.07	17	-	25	29	35	-	22	25	30
	900	425	0.03	7	-	-	23	30	-	-	-	21
14	3200	1510	0.25	62	28	35	39	45	30	35	38	43
	2700	1274	0.19	47	27	31	35	41	26	31	33	38
	2200	1038	0.12	30	23	28	31	38	21	26	29	34
	1700	802	0.06	15	-	24	28	34	-	21	23	28
16	4000	1888	0.21	52	26	33	36	44	31	36	39	45
	3500	1652	0.15	37	25	31	35	41	29	33	35	41
	3000	1416	0.11	27	23	29	31	38	24	30	32	37
	2000	944	0.04	10	-	23	28	31	-	-	23	28

Performance Notes:

1. NC levels are calculated from the published raw data and based on procedures outlined in AHRI Standard 885, Appendix E.
2. Discharge sound attenuation deductions are based on environmental effect, duct lining, branch power division, insulated flex duct, end reflection and space effect and are as follows:

Discharge attenuation	Octave Band						
	2	3	4	5	6	7	
< 300 cfm	24	28	39	53	59	40	
300 – 700 cfm	27	29	40	51	53	39	
> 700 cfm	29	30	41	51	52	39	

3. Radiated sound attenuation deductions are based on a mineral tile ceiling and environmental effect and are as follows:

Radiation attenuation	Octave Band						
	2	3	4	5	6	7	
Total dB reduction	18	19	20	26	31	36	

4. Min. inlet Δ Ps is the minimum static pressure required to achieve rated airflow (damper full open).
5. Dash (-) in space denotes an NC level of less than 20.

Performance Data • Discharge Sound Power Levels

Model 36VRR

Unit Size	Airflow cfm l/s		Min. inlet ΔPs "w.g. Pa		Sound Power Octave Bands Center @ Inlet Pressure ΔPs shown																							
					0.5" w.g. (125 Pa) ΔPs					1.0" w.g. (375 Pa) ΔPs					1.5" w.g. (375 Pa) ΔPs					3.0" w.g. (750 Pa) ΔPs								
					2	3	4	5	6	7	2	3	4	5	6	7	2	3	4	5	6	7	2	3	4	5	6	7
4	225	106	0.25	62	72	61	56	53	47	45	76	67	65	58	53	51	79	68	65	60	55	56	83	72	71	64	60	62
	200	94	0.20	50	70	60	55	51	46	44	75	65	60	56	52	50	78	67	63	58	54	54	82	71	67	63	59	60
	150	71	0.10	25	66	56	51	47	43	43	71	60	56	52	48	45	74	63	59	54	51	50	78	67	63	57	55	55
	100	47	0.05	12	61	50	47	37	38	38	66	54	51	46	42	40	69	57	54	49	45	46	73	61	59	52	45	48
5	350	165	0.32	80	72	60	55	53	49	50	77	65	60	56	54	56	78	69	64	59	57	60	84	74	69	64	62	66
	300	142	0.23	57	70	63	54	51	48	49	75	63	58	54	52	54	78	62	61	57	55	58	82	72	67	62	60	62
	200	94	0.11	27	64	53	49	46	42	44	70	58	54	50	47	49	72	61	57	52	50	53	78	67	62	57	55	58
	100	47	0.03	7	58	44	41	37	33	35	62	49	46	41	39	43	65	52	49	44	42	46	70	58	55	48	46	48
6	450	212	0.22	55	72	60	56	53	52	46	76	65	61	59	57	51	79	68	64	61	59	54	83	73	68	64	63	56
	400	189	0.18	45	70	58	54	53	51	44	75	63	59	58	56	49	77	72	62	59	57	52	81	71	66	63	61	55
	300	142	0.10	25	67	54	51	50	46	42	71	59	55	53	51	45	74	62	58	55	53	48	78	66	63	59	57	52
	200	94	0.04	10	62	48	46	45	42	40	66	53	50	43	46	41	69	56	53	50	48	44	73	61	58	53	53	49
7	650	307	0.21	52	61	57	57	58	56	49	66	62	61	61	59	53	69	65	64	63	62	58	74	70	68	66	66	62
	550	260	0.14	35	59	54	54	56	53	47	64	60	60	58	57	51	67	62	63	62	60	56	71	68	66	63	63	60
	450	212	0.10	25	57	52	52	53	51	45	61	57	56	51	54	48	64	60	59	58	57	54	69	64	64	61	60	56
	350	165	0.06	15	54	58	49	49	47	40	59	53	53	52	51	45	61	56	56	55	53	50	66	61	60	57	57	54
8	800	378	0.17	42	71	60	57	57	55	53	75	66	62	61	59	58	78	68	64	63	61	60	83	73	68	66	65	62
	700	330	0.13	32	69	59	56	56	54	51	74	64	60	59	58	56	76	67	63	62	60	58	81	71	67	65	64	60
	600	283	0.10	25	68	57	55	53	52	49	72	62	58	57	56	54	75	64	61	59	58	56	79	69	66	64	61	58
	400	189	0.04	10	65	52	49	48	46	42	68	58	54	53	52	47	71	60	57	54	52	50	75	65	61	58	56	55
9	1050	496	0.17	42	72	62	61	58	57	52	76	67	65	62	61	57	79	69	68	65	63	62	84	75	72	68	65	65
	850	401	0.11	27	69	59	59	56	53	50	71	64	63	60	58	54	76	67	65	62	61	59	82	71	69	66	65	62
	650	307	0.07	17	66	56	55	53	50	46	71	61	59	56	55	51	74	64	62	59	58	55	79	69	66	62	62	60
	450	212	0.03	7	62	52	51	48	46	41	66	56	55	52	51	44	70	59	58	54	53	50	74	64	62	59	58	57
10	1350	637	0.16	40	72	62	60	57	57	53	77	67	64	61	61	57	80	71	67	64	64	62	85	76	72	69	68	65
	1150	543	0.12	30	70	60	58	56	55	51	75	65	62	60	59	55	78	69	66	62	62	61	81	73	69	66	66	63
	950	448	0.09	22	68	57	56	53	52	49	73	63	60	58	57	54	76	66	64	60	59	60	81	71	67	64	64	62
	750	354	0.05	12	65	54	53	50	50	47	70	59	57	54	54	51	72	63	60	51	56	54	78	68	64	62	60	61
12	2100	991	0.19	47	73	65	63	61	60	55	79	70	67	66	64	59	82	73	70	67	67	64	87	76	74	72	72	69
	1700	802	0.12	30	71	62	60	58	57	53	76	67	65	62	61	58	79	70	67	64	64	62	84	75	72	69	68	67
	1300	614	0.07	17	67	58	57	54	53	50	73	64	61	58	58	55	76	67	64	61	60	60	81	71	68	65	64	64
	900	425	0.03	7	63	54	52	50	49	47	68	59	57	53	52	52	71	62	59	56	55	57	77	67	63	60	59	60
14	3200	1510	0.25	62	75	68	66	64	63	65	81	73	71	67	66	69	84	76	73	70	69	71	89	81	77	74	73	73
	2700	1274	0.19	47	73	65	64	61	61	63	78	70	68	65	65	67	81	73	71	68	67	69	86	78	75	71	71	72
	2200	1038	0.12	30	70	62	61	58	58	59	75	67	66	63	63	64	78	70	68	65	64	67	83	75	72	70	68	69
	1700	802	0.06	15	67	58	58	55	55	53	72	63	62	59	59	57	75	66	65	61	61	59	80	71	69	66	64	62
16	4000	1888	0.21	52	74	66	66	63	62	61	79	72	71	67	67	66	82	75	73	70	70	72	88	80	78	74	73	75
	3500	1652	0.15	37	73	65	64	62	61	60	78	70	69	66	65	62	81	74	72	68	67	68	86	79	76	72	71	72
	3000	1416	0.11	27	71	62	63	60	59	58	76	67	67	63	63	59	78	71	70	66	66	67	83	76	74	70	68	70
	2000	944	0.04	10	66	56	57	54	53	53	70	61	61	58	58	59	73	65	64	61	60	65	78	71	68	65	65	68

Performance Notes:

- Discharge sound power is the noise emitted from the unit discharge into the downstream duct.
- Sound power levels are in decibels, dB re 10⁻¹² watts.
- All sound data listed by octave bands is raw data without any corrections for room absorption or duct attenuation.
- Min. inlet ΔPs is the minimum operating pressure requirement (damper full open).
- Data derived from tests conducted in accordance with ANSI/ASHRAE Standard 130 and AHRI Standard 880.

Performance Data • Radiated Sound Power Levels

Model 36VRR

Unit Size	Airflow cfm l/s		Min. inlet ΔPs w.g. Pa		Sound Power Octave Bands Center @ Inlet Pressure ΔPs shown																							
					0.5" w.g. (125 Pa) ΔPs					1.0" w.g. (375 Pa) ΔPs					1.5" w.g. (375 Pa) ΔPs					3.0" w.g. (750 Pa) ΔPs								
					2	3	4	5	6	7	2	3	4	5	6	7	2	3	4	5	6	7	2	3	4	5	6	7
4	225	106	0.25	62	50	42	42	44	47	40	53	44	45	49	51	44	55	48	48	50	54	49	60	54	55	55	58	52
	200	94	0.20	50	49	37	38	40	44	38	48	40	42	45	47	40	50	43	45	46	49	41	53	45	47	49	52	45
	150	71	0.10	25	24	26	27	33	35	27	40	31	35	38	39	33	46	35	37	40	45	38	49	43	43	45	48	40
	100	47	0.05	12	-	-	-	24	28	-	-	-	26	29	34	26	-	21	26	30	37	31	42	33	34	36	40	34
5	350	165	0.32	80	54	45	45	46	47	41	55	51	52	52	54	46	60	52	52	53	55	50	65	57	58	58	60	55
	300	142	0.23	57	49	41	41	42	46	37	50	47	47	48	50	43	58	49	49	51	52	46	60	53	55	57	59	52
	200	94	0.11	27	43	26	35	38	40	27	42	38	39	41	44	33	48	40	41	43	45	36	53	45	46	46	48	42
	100	47	0.03	7	-	-	21	23	25	-	-	-	21	29	32	-	-	-	22	33	36	21	41	31	35	36	40	26
6	450	212	0.22	55	53	45	44	48	49	42	57	50	49	52	53	48	59	51	51	55	55	51	63	57	57	59	59	56
	400	189	0.18	45	51	42	42	46	41	39	55	47	47	50	51	45	57	50	50	52	53	48	61	52	54	57	58	53
	300	142	0.10	25	46	37	37	40	41	32	50	42	42	44	46	37	52	44	44	47	48	41	56	49	48	51	52	46
	200	94	0.04	10	30	25	28	32	34	22	43	23	34	37	39	27	45	36	37	39	41	30	49	41	41	44	45	36
7	650	307	0.21	52	53	44	44	42	48	45	59	52	52	53	54	51	61	52	53	52	54	54	64	58	58	57	59	64
	550	260	0.14	35	49	42	42	43	46	41	56	49	48	49	52	47	58	50	50	51	52	50	59	54	53	54	56	60
	450	212	0.10	25	45	38	37	39	43	36	51	43	43	44	46	42	52	44	45	45	47	45	55	50	51	52	54	53
	350	165	0.06	15	40	34	34	32	36	30	44	35	36	38	41	35	50	41	42	43	44	39	52	44	45	45	47	49
8	800	378	0.17	42	54	45	45	44	47	44	58	51	52	50	52	50	62	53	52	53	54	54	65	58	58	57	60	59
	700	330	0.13	32	52	43	43	41	45	41	57	50	50	51	51	46	59	50	50	49	53	51	60	54	53	54	57	56
	600	283	0.10	25	48	39	38	37	43	37	53	44	44	46	49	42	55	46	47	48	49	47	58	51	52	52	55	52
	400	189	0.04	10	44	32	30	29	35	27	43	34	35	35	40	32	49	40	42	43	44	37	51	43	44	43	46	42
9	1050	496	0.17	42	56	47	45	45	48	47	60	52	51	51	52	53	63	55	54	54	55	56	67	61	60	59	62	62
	850	401	0.11	27	53	43	43	43	44	42	56	47	47	46	49	47	59	51	50	48	53	51	63	56	57	56	58	56
	650	307	0.07	17	46	36	35	34	42	35	51	42	41	41	43	41	54	45	44	45	47	44	59	53	52	52	54	50
	450	212	0.03	7	42	29	27	26	30	26	47	34	33	32	37	32	49	35	36	35	45	35	51	46	47	45	49	41
10	1350	637	0.16	40	58	49	47	47	49	48	62	54	53	52	53	53	64	57	56	56	57	60	69	63	61	61	63	62
	1150	543	0.12	30	56	46	45	44	46	45	59	51	50	49	52	50	61	54	53	53	55	53	65	59	58	58	60	58
	950	448	0.09	22	52	42	41	41	43	41	56	48	46	46	48	45	58	51	49	49	51	48	62	55	55	54	56	55
	750	354	0.05	12	48	38	37	36	38	35	53	43	42	41	44	40	54	47	45	44	47	44	58	52	50	49	52	49
12	2100	991	0.19	47	63	55	54	53	53	52	66	59	58	57	58	58	68	62	61	59	62	61	72	66	65	64	65	66
	1700	802	0.12	30	57	51	49	48	49	48	61	55	54	51	54	53	64	57	56	55	57	57	68	61	60	59	61	61
	1300	614	0.07	17	52	45	44	43	44	41	56	48	48	47	48	47	58	51	51	50	52	50	62	54	55	51	56	55
	900	425	0.03	7	45	37	36	36	37	32	48	40	40	39	42	38	51	42	42	42	44	41	55	46	47	46	49	47
14	3200	1510	0.25	62	66	57	55	53	55	59	70	62	58	57	59	63	72	67	63	61	62	65	75	68	67	65	66	70
	2700	1274	0.19	47	63	54	52	50	52	51	66	58	56	54	56	57	68	61	58	56	58	61	72	65	63	61	63	67
	2200	1038	0.12	30	58	50	47	46	47	46	62	53	52	50	52	52	64	56	54	53	55	56	67	60	59	58	60	62
	1700	802	0.06	15	53	44	42	41	43	41	56	48	47	45	47	46	58	50	49	48	46	50	62	55	53	52	55	55
16	4000	1888	0.21	52	67	58	56	53	56	57	71	62	60	59	61	62	73	64	64	61	63	66	76	70	69	66	68	71
	3500	1652	0.15	37	65	55	52	51	54	54	68	60	58	56	58	59	70	62	60	58	59	61	73	67	66	64	65	67
	3000	1416	0.11	27	61	51	49	47	50	50	65	56	55	53	54	55	67	58	57	55	58	58	70	63	62	60	62	63
	2000	944	0.04	10	52	42	40	39	42	40	56	47	45	44	47	45	58	49	49	46	49	48	62	53	53	52	54	53

Performance Notes:

1. Radiated sound power is the breakout noise transmitted through the unit casing walls.

2. Sound power levels are in decibels, dB re 10⁻¹² watts.

3. All sound data listed by octave bands is raw data without any corrections for room absorption or duct attenuation.

4. Min. inlet ΔPs is the minimum operating pressure requirement (damper full open).

5. Data derived from tests conducted in accordance with ANSI/ASHRAE Standard 130 and AHRI Standard 880.

SLIDE-IN RETROFIT TERMINAL UNITS MODEL 36VRS

- SQUARE OR RECTANGULAR
- VARIABLE AIR VOLUME CONVERSION

A slide-in type Retrofit Air Terminal Unit for square or rectangular ductwork. Converts constant volume systems to variable air volume. Available in 15 individual valve sizes up to 15,000 cfm (7079 l/s). Nominal valve size is the same as smallest available duct size in table. Each unit (valve) size is available to suit various duct sizes as shown in the table. Top, bottom and/or side blank-off plates are used to bring valve up to the required nominal ductwork dimension. Airflow ranges are based on valve size and acoustical considerations for duct velocity. Model 36VRS is available to suit duct sizes within the tabulated range in 1" (25) increments.

Simple, low cost installation into existing ductwork. The installer cuts a rectangular hole in the side of the duct, cuts away the insulation (where present), slides the unit into the duct and screws the mounting plate to the side of the duct.

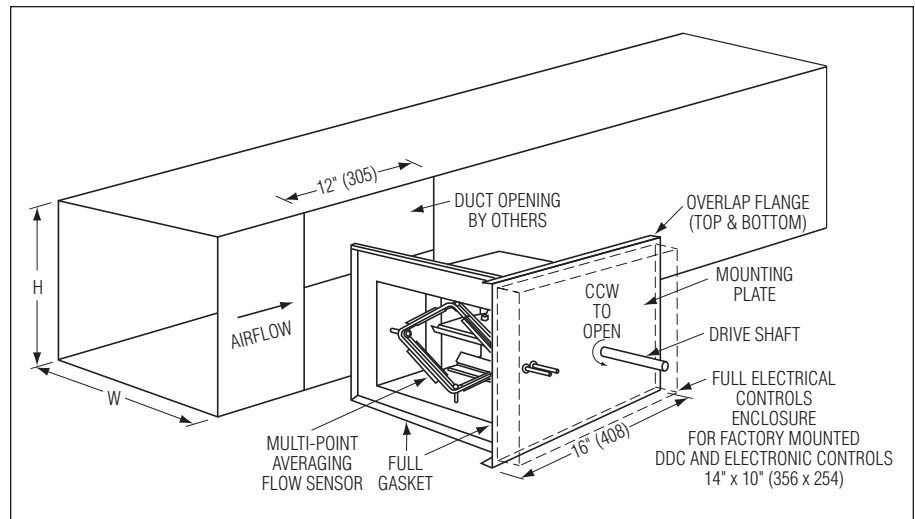

STANDARD FEATURES:

- Damper: 16 ga. (1.6) galvanized steel blade and frame construction with extruded PVC blade seals and metallic side jamb seals. Leakage is less than 2% of nominal CFM @ 3.0" w.g. (746 Pa) as tested in accordance with ASHRAE Standard 130.
- Bearings: Celcon[®].
- Drive Shaft: 1/2" (13) dia. plated steel, double-bolted to blade. Indicator mark on the end of the shaft to show damper position. 90° rotation. CW to close.
- Full electrical controls enclosure for factory mounted DDC and analog electronic controls.
- Multi-point averaging 'Diamond Flow' sensor: Aluminum. Gauge taps are provided for field balancing when controls are factory mounted.

- Gasket under the mounting plate and around periphery of terminal insert seal the unit to the sides of the duct.

Options:

- Controls enclosure for field mounted controls.
- 24 volt control transformer.
- Toggle disconnect switch.
- Pneumatic or Analog Electronic Pressure Independent controls by Nailor. Factory mounted and calibrated.
- Digital controls by BMS Contractor. Factory mounted by Nailor.

Dimensional Data:

Unit (valve) Size	Available Duct Size Width x Height	
	inches	mm
7	5 x 5 to 12 x 8	127 x 127 to 305 x 203
8	6 x 6 to 12 x 10	152 x 152 to 305 x 254
9	8 x 6 to 16 x 10	203 x 152 to 406 x 254
10	10 x 8 to 18 x 12	254 x 203 to 457 x 305
11	14 x 8 to 22 x 12	356 x 203 to 559 x 305
11A	18 x 6 to 26 x 10	457 x 152 to 660 x 254
12	12 x 10 to 22 x 14	305 x 254 to 559 x 356
13	18 x 10 to 28 x 14	457 x 254 to 711 x 356
14	18 x 12 to 28 x 16	457 x 305 to 711 x 406
15	20 x 14 to 30 x 18	508 x 356 to 762 x 457
15A	30 x 12 to 36 x 16	762 x 305 to 914 x 406
16	22 x 16 to 36 x 20	559 x 406 to 914 x 508
17	24 x 18 to 36 x 26	610 x 457 to 914 x 660
18	30 x 20 to 46 x 26	762 x 508 to 1168 x 660
19	40 x 20 to 52 x 26	1016 x 508 to 1321 x 660

Recommended Airflow Ranges For Model 36VRS Slide-in Retrofit Terminal Units

The recommended airflow ranges below are for terminal units with pressure independent controls and are based upon controller sensitivity limits as shown for each control type and acoustical consideration for duct velocity. For a given unit size, the minimum, auxiliary minimum (where applicable) and the maximum flow settings must be within the range limits to ensure pressure independent operation, accuracy and repeatability. For these reasons, factory settings will not be made outside these ranges. A minimum setting of zero (shut-off) is also available. Where an auxiliary setting is specified, the value must be greater than the minimum setting.

When digital or other controls are mounted by Nailor, but supplied by others, these values are guidelines only, based upon experience with the majority of controls currently available. Controls supplied by others for factory mounting are configured and calibrated in the field.



Model 36VRS

Model 36VRS Square or Rectangular

Unit Size	Nom. Valve Size	Min. – Max. Airflow Range				Available Duct Size Width x Height	
		Pneumatic		Digital/Analog			
		cfm	l/s	cfm	l/s	inches	mm
7	5 x 5	70 – 200	33 – 94	60 – 200	28 – 94	5 x 5 to 12 x 8	127 x 127 to 305 x 203
8	6 x 6	110 – 300	52 – 142	85 – 300	40 – 142	6 x 6 to 14 x 10	152 x 152 to 356 x 254
9	8 x 6	140 – 400	66 – 189	110 – 400	52 – 189	8 x 6 to 16 x 10	203 x 152 to 406 x 254
10	10 x 8	240 – 700	113 – 330	180 – 700	85 – 330	10 x 8 to 18 x 12	254 x 203 to 457 x 305
11	14 x 8	320 – 1000	151 – 472	260 – 1000	123 – 472	14 x 8 to 24 x 12	356 x 203 to 610 x 305
11A	18 x 6	310 – 1000	146 – 472	250 – 1000	118 – 472	18 x 6 to 26 x 10	457 x 152 to 660 x 254
12	12 x 10	350 – 1100	165 – 519	280 – 1100	132 – 519	12 x 10 to 22 x 14	305 x 254 to 559 x 356
13	18 x 10	500 – 1900	236 – 897	435 – 1900	205 – 897	18 x 10 to 30 x 14	457 x 254 to 762 x 356
14	18 x 12	650 – 2400	307 – 1133	540 – 2400	255 – 1133	18 x 12 to 28 x 16	457 x 305 to 711 x 406
15	20 x 14	850 – 3800	401 – 1794	700 – 3800	330 – 1794	20 x 14 to 30 x 18	508 x 356 to 762 x 457
15A	30 x 12	1020 – 5400	481 – 2549	870 – 5400	411 – 2549	30 x 12 to 36 x 16	762 x 305 to 914 x 406
16	22 x 16	1000 – 5400	472 – 2549	850 – 5400	401 – 2549	22 x 16 to 36 x 20	559 x 406 to 914 x 508
17	24 x 18	1250 – 6700	590 – 3162	1100 – 6700	519 – 3162	24 x 18 to 36 x 26	610 x 457 to 914 x 660
18	30 x 20	1750 – 10000	826 – 4720	1500 – 10000	708 – 4720	30 x 20 to 46 x 26	762 x 508 to 1168 x 660
19	40 x 20	2300 – 15000	1085 – 7080	1900 – 15000	897 – 7080	40 x 20 to 52 x 26	1016 x 508 to 1321 x 660

Performance Data • NC Level Application Guide

Model 36VRS

Inlet Size	Valve Size	Duct W x H	Airflow		Min. inlet ΔPs		NC Levels @ Inlet Pressure (ΔPs) shown							
							DISCHARGE				RADIATED			
							0.5" w.g. (125 Pa)	1.0" w.g. (250 Pa)	2.0" w.g. (500 Pa)	3.0" w.g. (750 Pa)	0.5" w.g. (125 Pa)	1.0" w.g. (250 Pa)	2.0" w.g. (500 Pa)	3.0" w.g. (750 Pa)
cfm	l/s	"w.g.	Pa											
7	5 x 5	5 x 5	70	33	0.004	1	-	23	31	36	22	30	36	40
			140	66	0.016	4	-	24	33	38	23	31	37	41
			200	94	0.033	8	-	25	34	39	24	32	38	42
		8 x 8	70	33	0.024	6	-	-	22	27	-	21	28	32
			140	66	0.094	23	-	-	24	29	-	23	29	33
			200	94	0.191	47	-	-	25	30	-	24	30	34
		12 x 8	70	33	0.043	11	-	-	-	22	-	-	23	27
			140	66	0.172	43	-	-	-	24	-	-	25	28
			200	94	0.350	87	-	-	20	25	-	20	26	29
8	6 x 6	6 x 6	110	52	0.004	1	-	24	33	38	25	31	38	42
			200	94	0.013	3	-	24	32	37	24	31	37	41
			300	142	0.030	7	-	25	34	39	25	32	38	42
		10 x 8	110	52	0.019	5	-	-	25	30	-	25	31	35
			200	94	0.064	16	-	-	25	30	-	24	30	34
			300	142	0.145	36	-	-	26	31	-	25	31	35
		14 x 10	110	52	0.039	10	-	-	20	25	-	20	26	30
			200	94	0.128	32	-	-	20	24	-	-	25	29
			300	142	0.288	72	-	-	20	26	-	20	26	30
9	8 x 6	8 x 6	140	66	0.004	1	-	23	31	36	23	30	36	40
			270	127	0.014	3	-	23	32	37	24	30	36	40
			400	189	0.031	8	-	24	32	37	24	31	37	41
		12 x 8	140	66	0.019	5	-	-	24	29	-	23	29	33
			270	127	0.070	17	-	-	25	30	-	24	30	34
			400	189	0.153	38	-	-	26	31	-	25	31	35
		16 x 10	140	66	0.031	8	-	-	20	25	-	-	26	29
			270	127	0.114	28	-	-	20	25	-	20	26	30
			400	189	0.251	62	-	-	21	26	-	20	27	30
10	10 x 8	10 x 8	240	113	0.007	2	-	23	32	37	24	30	36	40
			480	227	0.027	7	-	25	33	38	25	32	38	42
			700	330	0.057	14	-	26	34	39	26	32	39	43
		14 x 10	240	113	0.023	6	-	-	26	31	-	25	32	35
			480	227	0.091	23	-	-	28	33	20	27	33	37
			700	330	0.193	48	-	20	29	34	21	28	34	38
		18 x 12	240	113	0.050	12	-	-	21	26	-	20	26	30
			480	227	0.200	50	-	-	23	28	-	23	29	33
			700	330	0.426	106	-	-	24	29	-	24	30	34
11	14 x 8	14 x 8	320	151	0.006	1	-	-	28	33	20	26	33	36
			650	307	0.024	6	-	24	33	38	24	31	37	41
			1000	472	0.057	14	-	25	34	39	25	32	38	42
		18 x 10	320	151	0.017	4	-	-	23	28	-	22	29	32
			650	307	0.072	18	-	-	25	33	20	27	33	37
			1000	472	0.170	42	-	20	29	34	21	28	34	38
		24 x 14	320	151	0.042	10	-	-	-	33	-	-	23	27
			650	307	0.172	43	-	-	22	27	-	21	28	31
			1000	472	0.406	101	-	-	23	28	-	22	29	32
11A	18 x 6	18 x 6	310	146	0.007	2	-	-	28	33	20	26	33	36
			650	307	0.030	7	-	23	32	37	24	30	36	40
			1000	472	0.070	17	17	26	34	39	26	32	39	43
		22 x 8	310	146	0.025	6	-	-	22	27	-	21	27	31
			650	307	0.109	27	-	-	26	31	-	25	31	35
			1000	472	0.258	64	-	20	29	34	21	27	34	37
		26 x 10	310	146	0.037	9	-	-	20	25	-	-	25	29
			650	307	0.161	40	-	-	23	28	-	22	29	33
			1000	472	0.380	94	-	-	26	31	-	25	31	35
12	12 x 10	12 x 10	350	165	0.006	1	-	20	28	33	20	27	33	37
			725	342	0.025	6	-	24	33	38	25	31	37	41
			1100	519	0.057	14	-	26	34	39	26	32	39	43
		18 x 12	350	165	0.026	6	-	-	22	27	-	21	28	31
			725	342	0.110	27	-	-	26	31	-	25	31	35
			1100	519	0.253	63	-	-	27	32	20	26	32	36
		24 x 14	350	165	0.044	11	-	-	-	23	-	-	24	28
			725	342	0.188	47	-	-	23	28	-	22	28	32
			1100	519	0.433	108	-	-	24	29	-	23	30	34
13	18 x 10	18 x 10	500	236	0.006	1	-	21	30	35	22	28	35	38
			1200	566	0.034	8	-	25	34	39	26	32	38	42
			1900	897	0.084	21	-	25	34	39	25	32	38	42
		24 x 12	500	236	0.017	4	-	-	25	31	-	24	31	34
			1200	566	0.098	24	-	21	29	34	21	28	34	38
			1900	897	0.246	61	-	21	29	34	21	28	34	38
		30 x 14	500	236	0.030	7	-	-	22	27	-	21	27	31
			1200	566	0.173	43	-	-	26	31	-	25	31	35
			1900	897	0.434	108	-	-	26	31	-	25	31	35

RETROFIT TERMINAL UNITS

D

Performance Data • NC Level Application Guide

Model 36VRS

Inlet Size	Valve Size	Duct W x H	Airflow		Min. inlet ΔPs		NC Levels @ Inlet Pressure (ΔPs) shown							
							DISCHARGE				RADIATED			
							0.5" w.g. (125 Pa)	1.0" w.g. (250 Pa)	2.0" w.g. (500 Pa)	3.0" w.g. (750 Pa)	0.5" w.g. (125 Pa)	1.0" w.g. (250 Pa)	2.0" w.g. (500 Pa)	3.0" w.g. (750 Pa)
14	18 x 12	18 x 12	650	307	0.003	1	-	21	29	34	21	28	34	38
			1525	720	0.019	5	-	22	31	36	23	29	36	39
			2400	1133	0.048	12	-	24	33	38	25	31	37	41
		24 x 14	650	307	0.010	2	-	-	25	30	-	24	30	34
			1525	720	0.054	13	-	-	27	32	-	25	32	36
			2400	1133	0.134	33	-	20	29	34	21	27	34	37
		28 x 16	650	307	0.015	4	-	-	22	27	-	21	28	31
			1525	720	0.085	21	-	-	24	29	-	23	29	33
			2400	1133	0.210	52	-	-	26	31	-	25	31	35
15	20 x 14	20 x 14	850	401	0.004	1	-	20	29	34	21	27	33	37
			2325	1097	0.027	7	-	24	32	37	24	30	37	41
			3800	1793	0.073	18	-	25	34	39	26	32	39	42
		26 x 16	850	401	0.009	2	-	-	25	30	-	24	30	34
			2325	1097	0.071	18	-	20	29	34	21	27	33	37
			3800	1793	0.190	47	-	22	30	35	22	29	35	39
		30 x 18	850	401	0.041	10	-	-	23	28	-	21	28	32
			2325	1097	0.109	27	-	-	26	31	-	25	31	35
			3800	1793	0.290	72	-	-	28	33	20	26	33	37
15A	30 x 12	30 x 12	1020	481	0.003	1	-	21	29	34	21	27	34	37
			3200	1510	0.034	8	-	24	33	38	24	31	37	41
			5400	2548	0.098	24	-	26	34	39	26	32	39	43
		34 x 14	1020	481	0.007	2	-	-	27	32	-	25	31	35
			3200	1510	0.072	18	-	21	30	35	22	28	35	38
			5400	2548	0.204	51	-	23	32	37	24	30	36	40
		36 x 16	1020	481	0.010	2	-	-	25	30	-	23	30	33
			3200	1510	0.102	25	-	20	28	33	20	27	33	37
			5400	2548	0.290	72	-	21	30	35	22	28	35	38
16	22 x 16	22 x 16	1000	472	0.003	1	-	21	29	38	21	27	34	37
			3200	1510	0.026	6	-	24	33	38	24	31	37	41
			5400	2548	0.074	18	-	28	36	41	28	34	41	44
		28 x 18	1000	472	0.006	1	-	-	26	35	-	24	31	34
			3200	1510	0.063	16	-	20	29	34	21	28	34	38
			5400	2548	0.179	44	-	24	33	38	25	31	38	41
		36 x 20	1000	472	0.011	3	-	-	22	31	-	21	28	31
			3200	1510	0.112	28	-	-	26	31	-	24	31	35
			5400	2548	0.320	80	-	21	29	35	22	28	35	38
17	24 x 18	24 x 18	1250	590	0.003	1	-	21	29	34	21	27	34	37
			4000	1888	0.033	8	-	25	34	39	25	32	38	42
			6700	3162	0.092	23	-	28	36	41	28	34	41	44
		30 x 24	1250	590	0.010	2	-	-	24	29	-	23	29	33
			4000	1888	0.103	26	-	20	29	34	21	27	34	37
			6700	3162	0.290	72	-	23	31	36	23	30	36	40
		36 x 26	1250	590	0.015	4	-	-	22	27	-	21	27	31
			4000	1888	0.153	38	-	-	26	31	-	25	31	35
			6700	3162	0.430	107	-	20	29	34	21	28	34	38
18	30 x 20	30 x 20	1750	826	0.003	1	-	20	29	34	21	27	33	37
			5875	2773	0.030	7	-	28	36	41	28	34	41	45
			10000	4719	0.086	21	-	28	36	41	28	34	41	44
		38 x 24	1750	826	0.007	2	-	-	25	30	-	23	30	33
			5875	2773	0.080	20	-	24	32	37	24	31	37	41
			10000	4719	0.233	58	-	24	32	37	24	31	37	41
		46 x 26	1750	826	0.011	3	-	-	22	27	-	21	27	31
			5875	2773	0.124	31	-	21	30	35	22	28	35	39
			10000	4719	0.360	89	-	21	30	35	22	28	35	39
19	40 x 20	40 x 20	2300	1085	0.003	1	-	20	28	33	20	26	33	37
			8650	4082	0.038	9	-	26	35	40	26	33	39	43
			15000	7079	0.115	29	20	29	38	43	29	36	42	46
		46 x 24	2300	1085	0.006	1	-	-	25	35	-	24	30	34
			8650	4082	0.086	21	-	26	35	36	26	33	39	43
			15000	7079	0.258	64	-	26	34	37	26	33	39	43
		52 x 26	2300	1085	0.009	2	-	-	23	33	-	22	28	32
			8650	4082	0.123	31	-	26	35	34	26	33	39	43
			15000	7079	0.370	92	-	24	33	35	25	31	37	41

For full performance table notes, see page D7.

ROUND DUCT FLOW MEASURING STATIONS

MODEL 36FMI, INSERT TYPE
 MODEL 36FMS, SLEEVE TYPE
 MODEL 36FMSD, WITH BALANCING DAMPER

- MULTI-POINT AVERAGING FLOW SENSOR

The Model 36FMSD Flow Measuring Station is a multi-point averaging airflow sensor combined with integral balancing damper. The 36FMSD allows the field balancer to measure and adjust the airflow to a diffuser or other air terminal device located downstream.

The 36FMSD is an especially useful option for balancing individual displacement ventilation diffusers.

A chart is provided on the unit which gives airflow vs. signal differential pressure for direct reading of airflow.

STANDARD FEATURES:

- 22 ga. (0.86) corrosion-resistant steel casing with stiffening beads and corrosion-resistant steel blade up to 12" (305) dia., 20 ga. (1.00) over 12" (305) dia.
- Sized to fit nominal round duct sizes.
- Inlet and outlet stiffening beads provide a means for secure flexible duct connection.
- Balancing damper with hand locking quadrant.
- Multi-point averaging Diamond Flow Sensor: Aluminum construction.
- Sensor design minimizes pressure drop and regenerated noise.

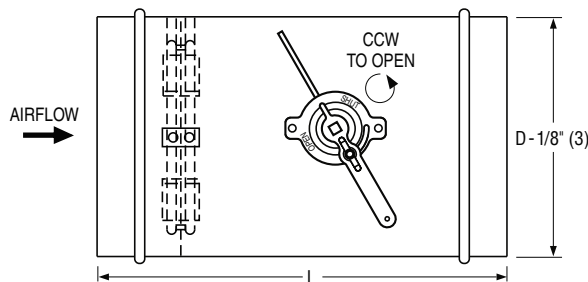
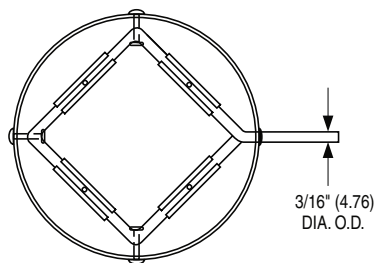
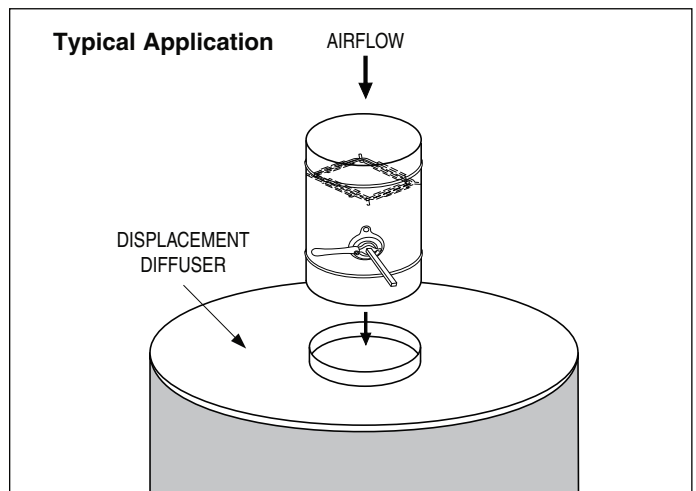
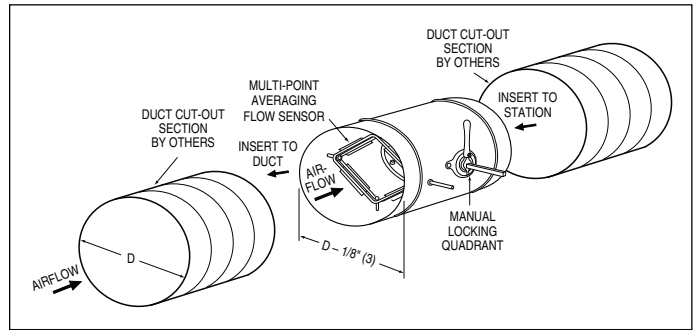

Dimensional Data – 36MSFD

Unit Size	Airflow Range cfm (l/s)	Duct Size D	Length L
4	0 – 225 (0 – 106)	4 (102)	13 (330)
5	0 – 400 (0 – 189)	5 (127)	13 (330)
6	0 – 550 (0 – 260)	6 (152)	13 (330)
7	0 – 800 (0 – 378)	7 (178)	13 (330)
8	0 – 1100 (0 – 519)	8 (203)	13 (330)
9	0 – 1400 (0 – 661)	9 (229)	13 (330)
10	0 – 1840 (0 – 868)	10 (254)	13 (330)
12	0 – 2500 (0 – 1180)	12 (305)	13 (330)
14	0 – 3125 (0 – 1475)	14 (356)	15 (381)
16	0 – 3725 (0 – 1758)	16 (406)	15 (381)
18	0 – 5880 (0 – 2775)	18 (457)	16 (406)



Suggested Specifications • 36VR Series

Model 36VRR • Basic Unit

1. Furnish and install **Nailor Model 36VRR Round External Duct Retrofit Terminal Unit** of the sizes and capabilities as indicated on the drawings. Units shall be pressure independent with (DDC, electronic, analog electronic, pneumatic) controls. Units shall reset to any flow between minimum and the maximum cataloged airflow as allowed by the specific controller.
2. The entire terminal unit shall be designed and built as a single unit. The unit shall be provided with a variable air volume damper that controls the air quantity in response to a (DDC, analog electronic or pneumatic) control signal. The unit shall also include all options such as control enclosure, transformer and toggle disconnect. The space limitations shall be reviewed carefully to insure that all units will fit into the space allowed.
3. Unit casings on sizes 4 through 12 shall be constructed of 22 ga. (.86) rolled galvanized steel with integral concentric stiffening beads. Unit sizes 14 and 16 shall be constructed of 20 ga. (1.00) rolled galvanized steel with integral concentric stiffening beads. Units shall be a minimum of 18" (457) in length. Length of the unit varies with size, not to exceed 22" (559) in length.
4. The damper shall be round and of laminated 2 x 20 ga. (1.00) galvanized steel construction with a polyurethane peripheral gasket and a solid steel 1/2" (13) diameter shaft, pivoted in corrosion free Celcon® bearings. Dampers shall be screwed through the shaft to insure that no slippage occurs. Damper leakage shall not exceed 2% of the terminal rated airflow at 3" w.g. (750 Pa) inlet static pressure as rated by ASHRAE standard 130.
5. Unit side mounting plate shall be constructed of 22 ga. (.86) galvanized steel and shall not be secured to casing with mechanical fasteners. Control enclosures, provided standard with Nailor mounted controls, shall meet the requirements of NEMA 1 classification and be fabricated of 22 ga. (.86) galvanized steel. The control enclosures shall not be secured to the mounting plate by the use of mechanical fasteners.
6. The terminal unit shall be capable of operation as described herein with a minimum inlet static pressure that shall not exceed .32" w.g. (80 Pa). (The sequence of operations should be described here, if not part of the controls specifications.) Each unit shall be complete with factory mounted (DDC, analog electronic or pneumatic) controls. Each unit shall be supplied with an aluminum multi-point averaging sensor. Gauge tap ports shall be supplied in the piping between the sensor and the controller.
7. Each unit shall be constructed with single point electrical or pneumatic connection. All electrical components shall be ETL or UL listed or recognized and installed in accordance with the National Electrical Code. All electrical components shall be installed in a control enclosure. The entire assembly shall be ETL listed and so labeled.
8. All sound data shall be compiled in an independent laboratory and in accordance with the latest version of AHRI Standard 880 and ANSI/ASHRAE Standard 130. Tabulated NC levels shall be calculated and presented in accordance with latest edition of AHRI Standard 885.

OPTIONS

Stainless Steel Construction:

(Substitute the following paragraphs:)

3. Unit casings on sizes 4 through 12 shall be constructed of 22 ga. (.86) rolled 304/316 [select one] stainless steel with integral concentric stiffening beads. Unit sizes 14 and 16 shall be constructed of 20 ga. (1.00) rolled 304/316 [select one] stainless steel with integral concentric stiffening beads. Units shall be a minimum of 18" (457) in length. Length of the unit varies with size, not to exceed 22" (559) in length.
4. The damper shall be round and of laminated 2 x 20 ga. (1.00) 304/316 [select one] stainless steel construction with a polyurethane peripheral gasket and a solid stainless steel 1/2" (13) diameter shaft, pivoted in corrosion free Celcon® bearings. Dampers shall be screwed through the shaft to insure that no slippage occurs. Damper leakage shall not exceed 2% of the terminal rated airflow at 3" w.g. (750 Pa) inlet static pressure as rated by ASHRAE standard 130.
5. Unit side mounting plate shall be constructed of 22 ga. (.86) 304/316 [select one] stainless steel and shall not be secured to casing with mechanical fasteners. Control enclosures, provided standard with Nailor mounted controls, shall meet the requirements of NEMA 1 classification and be fabricated of 22 ga. (.86) 304/316 [select one] stainless steel. The control enclosures shall not be secured to the mounting plate by the use of mechanical fasteners.
6. The terminal unit shall be capable of operation as described herein with a minimum inlet static pressure that shall not exceed .32" w.g. (80 Pa). (The sequence of operations should be described here, if not part of the controls specifications.) Each unit shall be complete with factory mounted (DDC, electronic, analog electronic or pneumatic) controls. Each unit shall be supplied with a stainless steel multi-point averaging sensor. Gauge tap ports shall be supplied in the piping between the sensor and the controller.

Control Transformer:

[Add the following paragraph(s):]

- Provide a 120 VAC or 208 VAC or 240 VAC or 277 VAC or 480 VAC or 600 VAC or 24/24 Isolation VAC control power transformer with an integral or separately mounted primary and/or secondary overcurrent protection device in accordance with NEC requirements.

Disconnect Switch:

[Add the following paragraph(s):]

- A 2-position, toggle type, disconnect switch shall be installed, labeled and rated to disconnect line voltage from the terminal unit.

Suggested Specifications

36VR Series

Model 36VRS • Basic Unit

1. Furnish and install **Nailor 36VRS Series Slide-In Retrofit Terminal Unit** of the sizes and capabilities as indicated on the drawings. Units shall be pressure independent with (DDC, analog electronic, pneumatic) controls. Units shall reset to any flow between minimum and the maximum cataloged airflow as allowed by the specific controller.
2. The entire terminal unit shall be designed and built as a single unit. The unit shall be provided with a variable air volume damper that controls the air quantity in response to a (DDC, analog electronic or pneumatic) control signal. The unit shall also include all options such as control enclosure, transformer and toggle disconnect. The space limitations shall be reviewed carefully to insure that all units will fit into the space allowed.
3. Damper assemblies of 16 ga. (1.6) galvanized steel shall be multiple opposed blade construction and arranged to close at 45 degrees from full open to minimize air turbulence and provide near linear operation. Damper blades shall be fitted with flexible seals for tight closure and minimized sound generation. Damper blades shall be screwed through ½" (13) plated solid steel shaft(s) to insure that no slippage occurs. Blade shafts shall pivot on corrosion free Celcon® bearings. In the fully closed position, air leakage past the closed damper shall not exceed 2% of the nominal catalog rating at 3" w.g. (746 Pa) inlet static pressure as rated by ASHRAE Standard 130.
4. Unit side mounting plate shall be constructed of 22 ga. (.86) galvanized steel and contain overlap flanges, top and bottom, to interface with ductwork. Control enclosures, provided standard with Nailor mounted controls, shall meet the requirements of NEMA 1 classification and be fabricated of 22 ga. (.86) galvanized steel.
5. The terminal units shall be capable of operation as described herein with a minimum inlet static pressure that shall not exceed .43" w.g. (107 Pa). (The sequence of operations should be described here, if not part of the controls specifications.) Each unit shall be complete with factory mounted (DDC, analog electronic or pneumatic) controls. Gauge tap ports shall be supplied in the piping between the flow pick up and the controller.
6. Each unit shall be constructed with single point electrical or pneumatic connection. All electrical components shall be ETL or UL listed or recognized and installed in accordance with the National Electrical Code. All electrical components shall be installed in a control enclosure. The entire assembly shall be ETL listed and so labeled.
7. All sound data shall be compiled in an independent laboratory and in accordance with the latest version of AHRI Standard 880 and ANSI/ASHRAE Standard 130. Tabulated NC levels shall be calculated and presented in accordance with latest edition of AHRI Standard 885.
8. The Slide-In Retrofit terminal unit shall be fully gasketed to provide a seal between terminal unit and ductwork.

OPTIONS

[Add the following paragraph(s):]

Control Transformer:

- Provide a 120 VAC or 208 VAC or 240 VAC or 277 VAC or 480 VAC or 600 VAC or 24/24 Isolation VAC control power transformer with an integral or separately mounted primary and/or secondary overcurrent protection device in accordance with NEC requirements.

Disconnect Switch:

- A 2-position, toggle type, disconnect switch shall be installed, labeled and rated to disconnect line voltage from the terminal unit.

3400 Series

Model 3400 • Basic Unit

General Information

Provide 3400 Series variable air volume bypass terminal units as manufactured by Nailor Industries. Performance and capacities shall be as scheduled on the drawings.

Construction

Unit casing shall be constructed of 22 ga. (0.86) zinc coated steel, acoustically and thermally lined with 3/4" (19) dual density insulation which meets the requirements of Standard NFPA 90A and UL 181. Units shall incorporate a heavy duty steel cylindrical flow diverter valve. Single blade pivoting dampers are not acceptable.

Units shall include integral inlet and bypass balancing dampers for field adjustment as standard components. Static pressure taps shall be provided to facilitate balancing.

Analog Electronic Controls

Units shall be provided with a modulating electronic control package. The 24 volt reversible actuator shall be factory mounted direct to the damper shaft and shall include an adjustable minimum air volume end stop as a standard feature.

The 24 volt modulating electronic thermostat for field mounting shall be supplied with a (°C) (°F) temperature scale. The thermostat shall be suitable for vertical wall mounting.

The thermostat shall be microprocessor based and provide proportional plus integral control of airflow and reheat when specified.

A 115 to 24 volt 20 VA transformer shall be provided, complete with all necessary hardware for field mounting.

A changeover thermistor shall be provided with control packages designed to control both heating and cooling supply air.

Pneumatic Controls

The control sequence shall be Direct acting (normally closed damper) or Reverse acting (normally open damper). All pneumatic actuators shall be furnished and factory installed by Nailor.

Water Reheat Coils

Hot water reheat units as scheduled shall include 1-row and/or 2-row coils. Coil capacities shall be as scheduled. A low-leakage access door shall be provided to allow cleaning and inspection of the coil. Coils shall be factory mounted on the discharge of the unit with slip and drive connections.

The coils shall be aluminum plate fin with copper tubes and sweat connections. Coil connections shall be right hand or left hand as detailed on drawings. Control valves, automatic air vents and drain vents, if required, shall be supplied and field installed by others.

Electric Reheat Coils

Electric reheat coils shall be ETL listed. They shall be factory mounted on the unit discharge in an extended attenuation section. Heating capacities and control components shall be as scheduled on the drawings.