



EXTRUDED ALUMINUM STATIONARY LOUVER
HIGH VELOCITY WIND-DRIVEN RAIN AND IMPACT RESISTANT
5" (127) DEEP • VERTICAL BLADE
MODEL: 1605WDV

QUALIFICATIONS:

- AMCA 500-L (Wind-Driven Rain, Water Penetration, Air Performance).
- AMCA 540 (Wind-Borne Debris Impact Test [Enhanced "Level E" Protection]).
- AMCA 550 (High Velocity Wind-Driven Rain Resistance Test).
- Wind load rating +/- 70 PSF.

STANDARD CONSTRUCTION:

- FRAME:** 5" (127) deep, Type 6063-T6 extruded aluminum, .080" (2.03) nominal wall thickness. Integral downspouts and caulking slot provided.
- BLADES:** Type 6063-T6 extruded aluminum, .060" (1.52) nominal wall thickness, with reinforcing bosses.
- BLADE ANGLE:** Fixed at 45 degrees.
- BLADE SPACING:** Approximately 1 1/2" (38) on centers.
- BLADE SUPPORT:** 2.5" (64) strap every 60" (1524) or less in height.
- SCREEN:** 3/4" x .050 (19 x 1.3) expanded, flattened aluminum bird screen in removable frame, inside (rear) mount (adds approximately 3/8" [10] to louver depth).
- FINISH:** Mill.
- MINIMUM SIZE:** 12" W x 12" H (305 x 305).
- MAX. SINGLE SECTION SIZE:** 72" W x 120" H (1829 x 3048) or 120" W x 72" H (3048 x 1829). 60 sq. ft. (5.6 m²). Larger louvers will require field assembly of smaller sections.
- MAXIMUM SIZE:** Unlimited Width x 120" H (3048).

OPTIONS:

- FL** Flanged Frame.
- BSSS** Type 304 S. S. Bird Screen.
- BSN** No Bird Screen.
- ISA** Aluminum Insect Screen.
- ISSS** Type 304 S. S. Insect Screen.
- ESI** Extended Sill.
- PASI** Sill Pan.
- PAAA** Perimeter Anchor Angles (Aluminum, Continuous).
- Other: _____.

OPTIONAL FINISHES:

- PC3** Powder Coat AAMA 2603. Color: _____.
- PC4** High Performance Powder Coat AAMA 2604 (Equivalent to 50% Kynar®). Color: _____.
- PC5** Fluoropolymer Powder Coat AAMA 2605 (Equivalent to 70% Kynar®). Color: _____.
- PCC** Prime Coat.

- AN04** Clear Anodized 204-R1.
- AN15** Clear Anodized 215-R1.
- ANLB** Light Bronze.
- ANMB** Medium Bronze.
- ANDB** Dark Bronze.
- ANBK** Black.

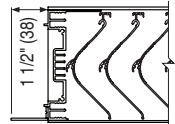
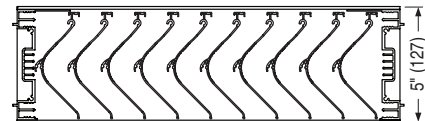
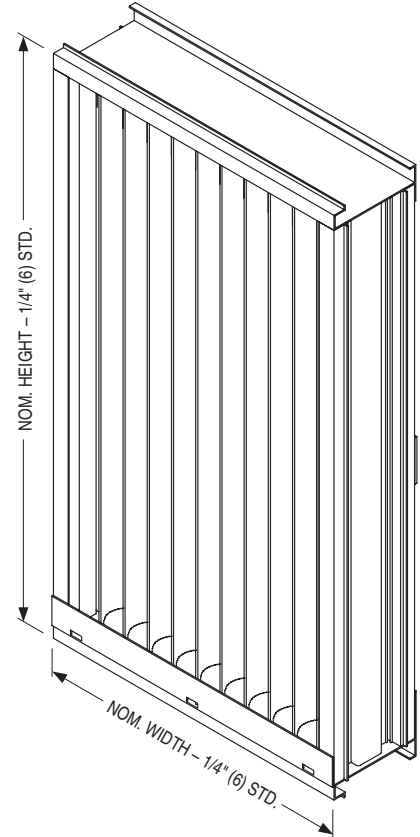

FLANGED FRAME (FL) (OPT.)



This label does not signify AMCA airflow performance certification.

SCHEDULE TYPE:		Page 1 of 3			
PROJECT:		Dimensions are in inches (mm).			
ENGINEER:	DATE	B SERIES	SUPERSEDES	DRAWING NO.	
CONTRACTOR:	6 - 25 - 21	1600	4 - 19 - 21	1605WDV	



EXTRUDED ALUMINUM STATIONARY LOUVER
HIGH VELOCITY WIND-DRIVEN RAIN AND IMPACT RESISTANT
5" (127) DEEP • VERTICAL BLADE • PERFORMANCE DATA
MODEL: 1605WDV

FREE AREA in Square Feet and Square Meters

		Width in Inches and Meters																		
		12	18	24	30	36	42	48	54	60	66	72	78	84	90	96	102	108	114	120
Height in Inches and Meters	12	0.28	0.51	0.74	0.96	1.19	1.42	1.65	1.87	2.10	2.33	2.55	2.78	3.01	3.24	3.46	3.69	3.92	4.14	4.37
	0.30	0.03	0.05	0.07	0.09	0.11	0.13	0.15	0.17	0.20	0.22	0.24	0.26	0.28	0.30	0.32	0.34	0.36	0.38	0.41
	18	0.49	0.89	1.28	1.68	2.07	2.47	2.86	3.26	3.65	4.05	4.44	4.83	5.23	5.62	6.02	6.41	6.81	7.20	7.60
	0.46	0.05	0.08	0.12	0.16	0.19	0.23	0.27	0.30	0.34	0.38	0.41	0.45	0.49	0.52	0.56	0.60	0.63	0.67	0.71
	24	0.63	1.14	1.65	2.15	2.66	3.17	3.67	4.18	4.69	5.19	5.70	6.20	6.71	7.22	7.72	8.23	8.74	9.24	9.75
	0.61	0.06	0.11	0.15	0.20	0.25	0.29	0.34	0.39	0.44	0.48	0.53	0.58	0.62	0.67	0.72	0.76	0.81	0.86	0.91
	30	0.84	1.52	2.19	2.87	3.54	4.21	4.89	5.56	6.24	6.91	7.58	8.26	8.93	9.61	10.28	10.96	11.63	12.30	12.98
	0.76	0.08	0.14	0.20	0.27	0.33	0.39	0.45	0.52	0.58	0.64	0.70	0.77	0.83	0.89	0.96	1.02	1.08	1.14	1.21
	36	1.05	1.89	2.74	3.58	4.42	5.26	6.10	6.95	7.79	8.63	9.47	10.31	11.15	12.00	12.84	13.68	14.52	15.36	16.21
	0.36	0.10	0.18	0.25	0.33	0.41	0.49	0.57	0.65	0.72	0.80	0.88	0.96	1.04	1.11	1.19	1.27	1.35	1.43	1.51
	42	1.26	2.27	3.28	4.29	5.30	6.31	7.32	8.33	9.34	10.35	11.36	12.37	13.38	14.39	15.39	16.40	17.41	18.42	19.43
	1.07	0.12	0.21	0.30	0.40	0.49	0.59	0.68	0.77	0.87	0.96	1.06	1.15	1.24	1.34	1.43	1.52	1.62	1.71	1.81
	48	1.47	2.65	3.83	5.00	6.18	7.36	8.53	9.71	10.89	12.07	13.24	14.42	15.60	16.77	17.95	19.13	20.31	21.48	22.66
	1.22	0.14	0.25	0.36	0.46	0.57	0.68	0.79	0.90	1.01	1.12	1.23	1.34	1.45	1.56	1.67	1.78	1.89	2.00	2.11
	54	1.68	3.03	4.37	5.72	7.06	8.41	9.75	11.09	12.44	13.78	15.13	16.47	17.82	19.16	20.51	21.85	23.20	24.54	25.89
	1.37	0.16	0.28	0.41	0.53	0.66	0.78	0.91	1.03	1.16	1.28	1.41	1.53	1.66	1.78	1.91	2.03	2.16	2.28	2.40
	60	1.89	3.40	4.92	6.43	7.94	9.45	10.97	12.48	13.99	15.50	17.02	18.53	20.04	21.55	23.07	24.58	26.09	27.60	29.12
	1.52	0.18	0.32	0.46	0.60	0.74	0.88	1.02	1.16	1.30	1.44	1.58	1.72	1.86	2.00	2.14	2.28	2.42	2.56	2.70
	66	2.10	3.78	5.46	7.14	8.82	10.50	12.18	13.86	15.54	17.22	18.90	20.58	22.26	23.94	25.62	27.30	28.98	30.66	32.34
	1.68	0.20	0.35	0.51	0.66	0.82	0.98	1.13	1.29	1.44	1.60	1.76	1.91	2.07	2.22	2.38	2.54	2.69	2.85	3.00
72	2.31	4.16	6.01	7.85	9.70	11.55	13.40	15.24	17.09	18.94	20.79	22.64	24.48	26.33	28.18	30.03	31.88	33.72	35.57	
1.83	0.21	0.39	0.56	0.73	0.90	1.07	1.24	1.42	1.59	1.76	1.93	2.10	2.27	2.45	2.62	2.79	2.96	3.13	3.30	
78	2.52	4.53	6.55	8.57	10.58	12.60	14.61	16.63	18.64	20.66	22.67									
1.98	0.23	0.42	0.61	0.80	0.98	1.17	1.36	1.54	1.73	1.92	2.11									
84	2.73	4.91	7.10	9.28	11.46	13.64	15.83	18.01	20.19	22.38	24.56									
2.13	0.25	0.46	0.66	0.86	1.06	1.27	1.47	1.67	1.88	2.08	2.28									
90	2.94	5.29	7.64	9.99	12.34	14.69	17.04	19.39	21.75	24.10	26.45									
2.29	0.27	0.49	0.71	0.93	1.15	1.36	1.58	1.80	2.02	2.24	2.46									
96	3.15	5.67	8.19	10.70	13.22	15.74	18.26	20.78	23.30	25.81	28.33									
2.44	0.29	0.53	0.76	0.99	1.23	1.46	1.70	1.93	2.16	2.40	2.63									
102	3.36	6.04	8.73	11.42	14.10	16.79	19.47	22.16	24.85	27.53	30.22									
2.59	0.31	0.56	0.81	1.06	1.31	1.56	1.81	2.06	2.31	2.56	2.81									
108	3.57	6.42	9.27	12.13	14.98	17.84	20.69	23.54	26.40	29.25	32.11									
2.74	0.33	0.60	0.86	1.13	1.39	1.66	1.92	2.19	2.45	2.72	2.98									
114	3.78	6.80	9.82	12.84	15.86	18.88	21.91	24.93	27.95	30.97	33.99									
2.90	0.35	0.63	0.91	1.19	1.47	1.75	2.04	2.32	2.60	2.88	3.16									
120	3.99	7.18	10.36	13.55	16.74	19.93	23.12	26.31	29.50	32.69	35.88									
3.05	0.37	0.67	0.96	1.26	1.56	1.85	2.15	2.44	2.74	3.04	3.33									



SCHEDULE TYPE:	Page 2 of 3			
PROJECT:	Dimensions are in inches (mm).			
ENGINEER:	DATE	B SERIES	SUPERSEDES	DRAWING NO.
CONTRACTOR:	6 - 25 - 21	1600	4 - 19 - 21	1605WDV



EXTRUDED ALUMINUM STATIONARY LOUVER
HIGH VELOCITY WIND-DRIVEN RAIN AND IMPACT RESISTANT
5" (127) DEEP • VERTICAL BLADE • PERFORMANCE DATA
MODEL: 1605WDV

AIRFLOW/WATER PENETRATION DATA
for 48" x 48" (1219 x 1219) Louver Size

Free Area %		53%
Free Area sq. ft. (sq. m.)		8.53 (0.79)
I N T A K E	Free Area Velocity at Point of Beginning Water Penetration at .01 oz./sq. ft. (3 ml/sq. m) (15 min. test duration)	1250 fpm (381 m/min.)*
	Air Volume at 1250 fpm	10,663 cfm (5032 l/s)
	Free Area Velocity	
	Pressure Drop @ 1250 fpm	.29 in. w.g. (72 Pa)

NOTE: To minimize water penetration when sizing intake louvers, select a Free Area Velocity that is **below** the beginning point of water penetration.*Maximum Free Area Velocity tested is 1250 fpm. Beginning point of water penetration for this model is above 1250 fpm.

WIND DRIVEN RAIN PERFORMANCE

Core Ventilation Rate in fpm (m/s)	0 (0.00)	110 (0.56)	195 (0.99)	279 (1.42)	396 (2.01)	497 (2.52)	588 (2.99)	701 (3.56)	781 (3.97)	891 (4.53)	984 (5.00)
Free Area Ventilation Rate in fpm (m/s)	0 (0.00)	208 (1.06)	368 (1.87)	526 (2.67)	747 (3.79)	938 (4.77)	1109 (5.63)	1323 (6.72)	1474 (7.49)	1681 (8.54)	1857 (9.43)
Effectiveness Ratio (%)	100	100	100	100	100	100	100	100	100	100	100
Penetration Class	A	A	A	A	A	A	A	A	A	A	A

Test was based on a 39.375" x 39.375" (1.0 m x 1.0 m) core area louver tested at a rainfall rate of 3" per hour (76 mm/hour) with a wind velocity of **29 mph (13 m/s)**.

DISCHARGE LOSS COEFFICIENT CLASS (INTAKE): 2. (Discharge Loss Coefficient Classification is as follows: 1=0.4 and above, 2=0.3 to 0.399, 3 = 0.2 to 0.299, 4 = 0.199 and below.)

Core Ventilation Rate in fpm (m/s)	0 (0.00)	88 (0.45)	199 (1.01)	301 (1.53)	400 (2.03)	485 (2.46)	590 (3.00)	687 (3.49)	787 (4.00)	883 (4.49)	987 (5.01)
Free Area Ventilation Rate in fpm (m/s)	0 (0.00)	166 (0.84)	375 (1.91)	568 (2.89)	755 (3.84)	915 (4.65)	1113 (5.65)	1296 (6.58)	1485 (7.54)	1666 (8.46)	1862 (9.46)
Effectiveness Ratio (%)	100	100	100	100	100	100	100	100	100	100	100
Penetration Class	A	A	A	A	A	A	A	A	A	A	A

Test was based on a 39.375" x 39.375" (1.0 m x 1.0 m) core area louver tested at a rainfall rate of 8" per hour (203 mm/hour) with a wind velocity of **50 mph (22 m/s)**.

DISCHARGE LOSS COEFFICIENT CLASS (INTAKE): 2. (Discharge Loss Coefficient Classification is as follows: 1=0.4 and above, 2=0.3 to 0.399, 3 = 0.2 to 0.299, 4 = 0.199 and below.)

PRESSURE DROP

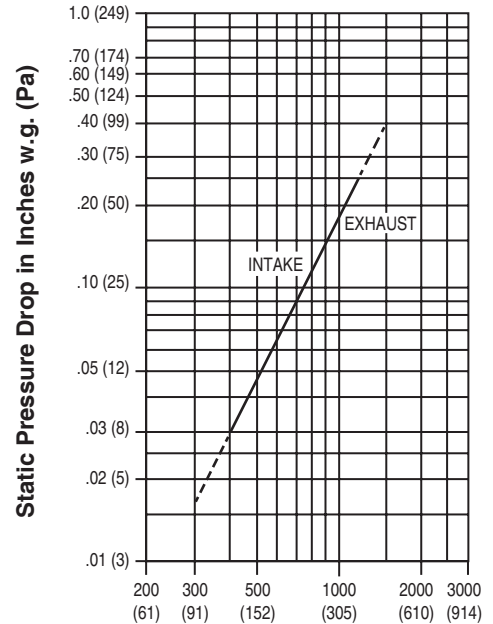

Air Velocity in Feet (Meters) Per Minute Through Free Area

Louver test size: 48" x 48" (1219 x 1219 mm).
 Standard air density @ 0.075 lbs/ft³.
 Tested to AMCA Fig. 5.5 – 6.5.



Nailor Industries Inc. certifies the Model 1605WDV shown herein is licensed to bear the AMCA Seal. The ratings shown are based on tests and procedures performed in accordance with AMCA Publication 511 and comply with the requirements of the AMCA Certified Ratings Program. Seal applies to air performance, water penetration, and wind driven rain performance ratings.



Nailor Industries Inc. certifies that the 1605WDV shown herein is approved to bear the AMCA Listing Label. The ratings shown are based on tests and procedures performed in accordance with AMCA publications and comply with the requirements of the AMCA Listing Label Program. The AMCA Listing Label applies to Wind Borne Debris Impact Resistant Louvers. The AMCA Listing Label applies to High Velocity Wind Driven Rain Resistant Louvers.

SCHEDULE TYPE:	Page 3 of 3 Dimensions are in inches (mm).			
PROJECT:				
ENGINEER:	DATE	B SERIES	SUPERSEDES	DRAWING NO.
CONTRACTOR:	6 - 25 - 21	1600	4 - 19 - 21	1605WDV



**EXTRUDED ALUMINUM COMBINATION LOUVER/DAMPER
HIGH VELOCITY WIND-DRIVEN RAIN AND IMPACT RESISTANT
6" (152) DEEP • DRAINABLE BLADE • OPERABLE AIRFOIL DAMPER
MODEL: 1606C**

QUALIFICATIONS:

- AMCA 500-L (Water Penetration, Air Performance).
- AMCA 540 (Wind-Borne Debris Impact Test [Basic "Level D" Protection]).
- AMCA 550 (High Velocity Wind-Driven Rain Resistance Test [with blades closed]).
- Wind load rating +/- 70 PSF

STANDARD CONSTRUCTION:

- FRAME:** 6" (152) deep, Type 6063-T6 extruded aluminum, 0.120" (3.05) nominal wall thickness. Integral downspouts and caulking slot provided.
- BLADES:** Front Stationary Blades: Drainable style, Type 6063-T6 extruded aluminum, 0.080" (2.03) nominal wall thickness. Fixed at 37.5 degrees.
Rear Operable Blades: Airfoil style, Type 6063-T6 extruded aluminum, 0.080" (2.03) nominal wall thickness.
- BLADE SPACING:** Approximately 4.84" (123) on centers.
- BLADE SEALS:** Santoprene. Mechanically locked in place.
- JAMB SEALS:** Cambered stainless steel.
- BEARINGS:** 1/2" (13) dia. Celcon®.
- AXLES:** 1/2" (13) dia. plated steel double bolted to blades.
- LINKAGE:** Concealed in frame.
- SCREEN:** 3/4" x .050 (19 x 1.3) expanded, flattened aluminum bird screen in removable frame, inside (rear) mount (adds approximately 3/8" [10] to louver depth).
- ACTUATOR:** Hand locking louver quadrant.
- FINISH:** Mill.
- MINIMUM SIZE:** 12" W x 16" H (305 x 406).
- MAX. SINGLE SECTION SIZE:** 60" W x 120" H (1524 x 3048). 50 sq. ft. (4.6 m²). Larger louvers will require field assembly of smaller sections.
- MAXIMUM SIZE:** Unlimited Width x 120" H (3048).

OPTIONS:

- BSSS** Type 304 S.S. Bird Screen.
- BSN** No Bird Screen.
- ISA** Aluminum Insect Screen.
- ISSS** Type 304 S.S. Insect Screen.
- FL15** 1 1/2" (38) Flanged Frame.
- ESI** Extended Sill.
- PASI** Sill Pan.
- ACT** Electric Actuator.
Specify: _____.
- PAAA** Perimeter Anchor Angles
(Aluminum, Continuous).
- Other:** _____.

OPTIONAL FINISHES:

- PC3** Powder Coat AAMA 2603.
Color: _____.
- PC4** High Performance Powder Coat AAMA 2604 (Equivalent to 50% Kynar®).
Color: _____.
- PC5** Fluoropolymer Powder Coat AAMA 2605 (Equivalent to 70% Kynar®). Color: _____.
- PPC** Prime Coat.
- AN04** Clear Anodized 204-R1.
- AN15** Clear Anodized 215-R1.
- ANLB** Light Bronze.
- ANMB** Medium Bronze.
- ANDB** Dark Bronze.
- ANBK** Black.

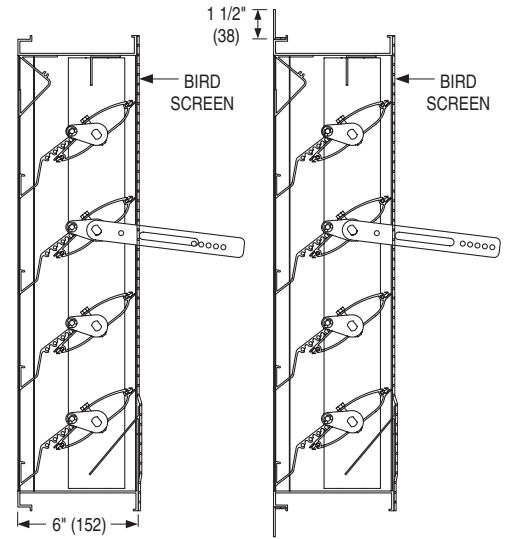
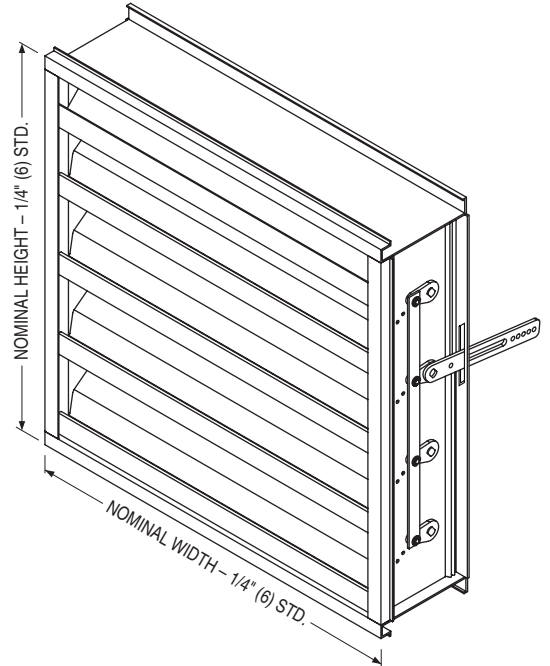

FLANGED FRAME FL (OPT.)



SCHEDULE TYPE:

PROJECT:

ENGINEER:

CONTRACTOR:

Page 1 of 2
Dimensions are in inches (mm).

DATE	B SERIES	SUPERSEDES	DRAWING NO.
8 - 2 - 23	1600M	8 - 19 - 22	1606C



**EXTRUDED ALUMINUM COMBINATION LOUVER/DAMPER
HIGH VELOCITY WIND-DRIVEN RAIN AND IMPACT RESISTANT
6" (152) DEEP • DRAINABLE BLADE • OPERABLE AIRFOIL DAMPER
PERFORMANCE DATA
MODEL: 1606C**

FREE AREA in Square Feet and Square Meters

		Width in Inches and Meters								
		12	18	24	30	36	42	48	54	60
Height in Inches and Meters	12	0.19	0.30	0.41	0.53	0.64	0.76	0.87	0.98	1.10
	0.30	0.02	0.03	0.04	0.05	0.06	0.07	0.08	0.09	0.10
	18	0.37	0.60	0.83	1.06	1.28	1.51	1.74	1.97	2.20
	0.46	0.03	0.06	0.08	0.10	0.12	0.14	0.16	0.18	0.20
	24	0.85	1.36	1.88	2.40	2.91	3.43	3.94	4.46	4.98
	0.61	0.08	0.13	0.17	0.22	0.27	0.32	0.37	0.41	0.46
	30	1.03	1.66	2.29	2.92	3.55	4.18	4.81	5.44	6.07
	0.76	0.10	0.15	0.21	0.27	0.33	0.39	0.45	0.51	0.56
	36	1.22	1.96	2.71	3.45	4.20	4.94	5.68	6.43	7.17
	0.36	0.11	0.18	0.25	0.32	0.39	0.46	0.53	0.60	0.67
	42	1.41	2.26	3.12	3.98	4.84	5.70	6.55	7.41	8.27
	1.07	0.13	0.21	0.29	0.37	0.45	0.53	0.61	0.69	0.77
	48	1.59	2.56	3.53	4.50	5.47	6.44	7.40	8.38	9.35
	1.22	0.15	0.24	0.33	0.42	0.51	0.60	0.69	0.78	0.87
	54	1.94	3.12	4.30	5.49	6.67	7.85	9.04	10.22	11.40
	1.37	0.18	0.29	0.40	0.51	0.62	0.73	0.84	0.95	1.06
	60	2.15	3.47	4.78	6.09	7.41	8.72	10.03	11.35	12.66
	1.52	0.20	0.32	0.44	0.57	0.69	0.81	0.93	1.05	1.18
	66	2.34	3.77	5.19	6.62	8.05	9.48	10.90	12.33	13.76
	1.68	0.22	0.35	0.48	0.62	0.75	0.88	1.01	1.15	1.28
72	2.53	4.07	5.61	7.15	8.69	10.23	11.77	13.32	14.86	
1.83	0.23	0.38	0.52	0.66	0.81	0.95	1.09	1.24	1.38	
78	2.90	4.67	6.44	8.21	9.98	11.75	13.51	15.28	17.05	
1.98	0.27	0.43	0.60	0.76	0.93	1.09	1.26	1.42	1.58	
84	3.09	4.97	6.85	8.74	10.62	12.50	14.38	16.27	18.15	
2.13	0.29	0.46	0.64	0.81	0.99	1.16	1.34	1.51	1.69	
90	3.27	5.27	7.27	9.26	11.26	13.26	15.25	17.25	19.25	
2.29	0.30	0.49	0.68	0.86	1.05	1.23	1.42	1.60	1.79	
96	3.46	5.57	7.68	9.79	11.90	14.01	16.12	18.23	20.34	
2.44	0.32	0.52	0.71	0.91	1.11	1.30	1.50	1.69	1.89	
102	3.65	5.87	8.10	10.32	12.54	14.77	16.99	19.22	21.44	
2.59	0.34	0.55	0.75	0.96	1.17	1.37	1.58	1.79	1.99	
108	4.02	6.47	8.93	11.38	13.83	16.28	18.73	21.19	23.64	
2.74	0.37	0.60	0.83	1.06	1.28	1.51	1.74	1.97	2.20	
114	4.21	6.77	9.34	11.91	14.47	17.04	19.60	22.17	24.74	
2.90	0.39	0.63	0.87	1.11	1.34	1.58	1.82	2.06	2.30	
120	4.39	7.07	9.75	12.43	15.11	17.79	20.47	23.15	25.83	
3.05	0.41	0.66	0.91	1.16	1.40	1.65	1.90	2.15	2.40	

PRESSURE DROP

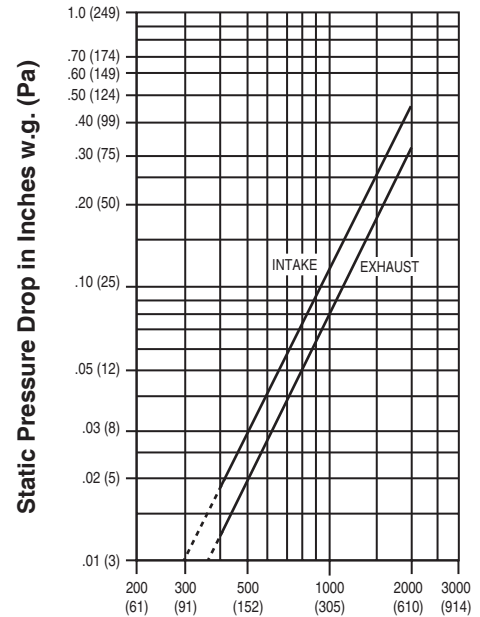

Air Velocity in Feet (Meters) Per Minute Through Free Area

Louver test size: 48" x 48" (1219 x 1219 mm).
Standard air density @ 0.075 lbs/ft³.
Tested to AMCA Fig. 5.5 – 6.5.

AIRFLOW/WATER PENETRATION DATA for 48" x 48" (1219 x 1219) Louver Size

Free Area %	46 %
Free Area sq. ft. (sq. m.)	7.40 (0.69)
Free Area Velocity at Point of Beginning Water Penetration at .01 oz./sq. ft. (3 ml/sq. m) (15 min. test duration)	1178 fpm (359 m/min.)
Air Volume at 1178 fpm Free Area Velocity	8717 cfm (4114 l/s)
Pressure Drop @ 1178 fpm	0.16 in. w.g. (40 Pa)

NOTE: To minimize water penetration when sizing intake louvers, select a Free Area Velocity that is **below** the beginning point of water penetration.



Nailor Industries Inc. certifies the Model 1606C shown herein is licensed to bear the AMCA Seal. The ratings shown are based on tests and procedures performed in accordance with AMCA Publication 511 and comply with the requirements of the AMCA Certified Ratings Program. Seal applies to air performance and water penetration ratings.



Nailor Industries Inc. certifies that the 1606C shown herein is approved to bear the AMCA Listing Label. The ratings shown are based on tests and procedures performed in accordance with AMCA publications and comply with the requirements of the AMCA Listing Label Program. The AMCA Listing Label applies to Wind Borne Debris Impact Resistant Louvers. The AMCA Listing Label applies to High Velocity Wind Driven Rain Resistant Louvers.

SCHEDULE TYPE:	Page 2 of 2			
PROJECT:	Dimensions are in inches (mm).			
ENGINEER:	DATE	B SERIES	SUPERSEDES	DRAWING NO.
CONTRACTOR:	8 - 2 - 23	1600M	8 - 19 - 22	1606C



EXTRUDED ALUMINUM STATIONARY HYBRID LOUVER
HIGH VELOCITY WIND-DRIVEN RAIN AND IMPACT RESISTANT
9" (229) DEEP • HORIZONTAL AND VERTICAL BLADE
MODEL: 1609H

QUALIFICATIONS:

- AMCA 500-L (Wind-Driven Rain, Water Penetration, Air Performance).
- AMCA 540 (Wind-Borne Debris Impact Test [Enhanced "Level E" Protection]).
- AMCA 550 (High Velocity Wind-Driven Rain Resistance Test).
- Wind load rating +/- 70 PSF.

STANDARD CONSTRUCTION:

FRAME: **Front:** 4" (102) deep, Type 6063-T6 extruded aluminum, .080" (2.03) nominal wall thickness. Integral caulking slot provided.
Rear: 5" (127) deep, Type 6063-T6 extruded aluminum, .080" (2.03) nominal wall thickness. Integral downspouts provided.

BLADES: **Front:** Horizontal Type 6063-T6 extruded aluminum, .080" (2.03) nominal wall thickness, with reinforcing bosses. J style. Fixed at 37 degrees.
Rear: Vertical Type 6063-T6 extruded aluminum, .060" (1.52) nominal wall thickness, with reinforcing bosses.

BLADE SPACING: **Front:** Approximately 4" (102) on centers.
Rear: Approximately 1 1/2" (38) on centers.

BLADE SUPPORT **Front:** Concealed type, factory installed on rear of louver on maximum 60" (1524) centers.
Rear: 2.5" (64) strap every 60" (1524) or less in height.

SCREEN: 3/4" x .050 (19 x 1.3) expanded, flattened aluminum bird screen in removable frame, inside (rear) mount (adds approximately 3/8" [10] to louver depth).

SILL PAN: Aluminum sill pan with end dams. (louver width undersized an additional 1/4" (6) to accommodate sill pan).

FINISH: Mill.

MINIMUM SIZE: 12" W x 12" H (305 x 305).

MAX. SINGLE SECTION SIZE: 60" W x 120" H (1524 x 3048). 50 sq. ft. (4.6 m²). Larger louvers will require field assembly of smaller sections.

MAXIMUM SIZE: Unlimited Width x 120" H (3048).

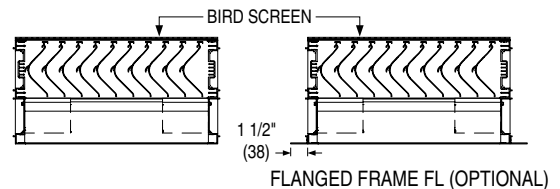
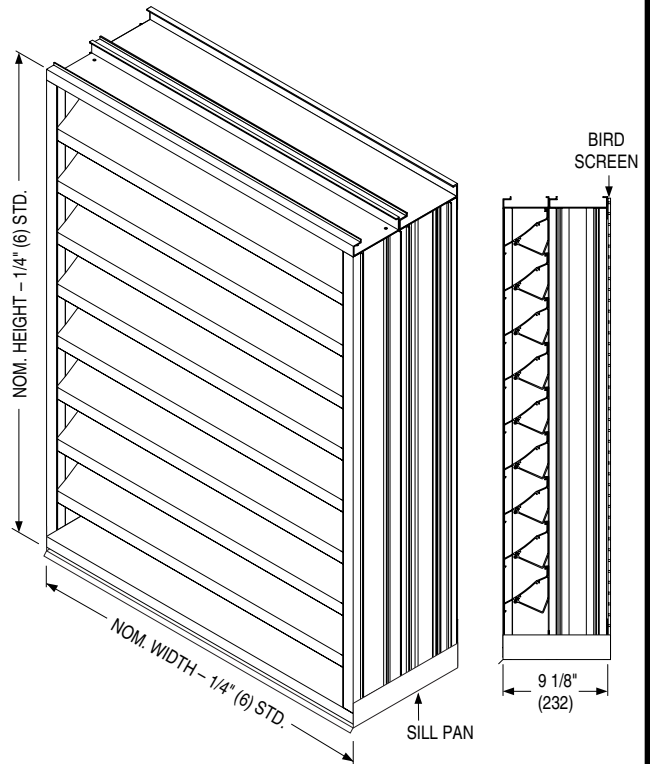

OPTIONS:

- BSSS Type 304 S.S. Bird Screen.
- BSN No Bird Screen.
- ISSS Type 304 S.S. Insect Screen.
- ISA Aluminum Insect Screen.
- FL Flanged Frame.
- PAAA Perimeter Anchor Angles (Aluminum, Continuous).
- Other: _____.

OPTIONAL FINISHES:

- PC3 Powder Coat AAMA 2603. Color: _____.
- PC4 High Performance Powder Coat AAMA 2604 (Equivalent to 50% Kynar®). Color: _____.
- PC5 Fluoropolymer Powder Coat AAMA 2605 (Equivalent to 70% Kynar®). Color: _____.
- PCC Prime Coat.
- AN04 Clear Anodized 204-R1.
- AN15 Clear Anodized 215-R1.

- ANLB Light Bronze.
- ANMB Medium Bronze.
- ANDB Dark Bronze.
- ANBK Black.

SCHEDULE TYPE:	Page 1 of 3			
PROJECT:	Dimensions are in inches (mm).			
ENGINEER:	DATE	B SERIES	SUPERSEDES	DRAWING NO.
CONTRACTOR:	7 - 6 - 21	1600M	NEW	1609H



**EXTRUDED ALUMINUM STATIONARY HYBRID LOUVER
HIGH VELOCITY WIND-DRIVEN RAIN AND IMPACT RESISTANT
9" (229) DEEP • HORIZONTAL AND VERTICAL BLADE
PERFORMANCE DATA
MODEL: 1609H**

FREE AREA in Square Feet and Square Meters

		Width in Inches and Meters								
		12	18	24	30	36	42	48	54	60
Height in Inches and Meters	12	0.21	0.39	0.56	0.73	0.90	1.07	1.24	1.41	1.58
	0.30	0.02	0.04	0.05	0.07	0.08	0.10	0.12	0.13	0.15
	18	0.42	0.76	1.10	1.44	1.78	2.12	2.46	2.80	3.13
	0.46	0.04	0.07	0.10	0.13	0.17	0.20	0.23	0.26	0.29
	24	0.63	1.14	1.65	2.15	2.66	3.17	3.67	4.18	4.69
	0.61	0.06	0.11	0.15	0.20	0.25	0.29	0.34	0.39	0.44
	30	0.84	1.52	2.19	2.87	3.54	4.21	4.89	5.56	6.24
	0.76	0.08	0.14	0.20	0.27	0.33	0.39	0.45	0.52	0.58
	36	1.05	1.89	2.74	3.58	4.42	5.26	6.10	6.95	7.79
	0.36	0.10	0.18	0.25	0.33	0.41	0.49	0.57	0.65	0.72
	42	1.26	2.27	3.28	4.29	5.30	6.31	7.32	8.33	9.34
	1.07	0.12	0.21	0.30	0.40	0.49	0.59	0.68	0.77	0.87
	48	1.47	2.65	3.83	5.00	6.18	7.36	8.53	9.71	10.89
	1.22	0.14	0.25	0.36	0.46	0.57	0.68	0.79	0.90	1.01
	54	1.68	3.03	4.37	5.72	7.06	8.41	9.75	11.09	12.44
	1.37	0.16	0.28	0.41	0.53	0.66	0.78	0.91	1.03	1.16
	60	1.89	3.40	4.92	6.43	7.94	9.45	10.97	12.48	13.99
	1.52	0.18	0.32	0.46	0.60	0.74	0.88	1.02	1.16	1.30
	66	2.10	3.78	5.46	7.14	8.82	10.50	12.18	13.86	15.54
	1.68	0.20	0.35	0.51	0.66	0.82	0.98	1.13	1.29	1.44
72	2.31	4.16	6.01	7.85	9.70	11.55	13.40	15.24	17.09	
1.83	0.21	0.39	0.56	0.73	0.90	1.07	1.24	1.42	1.59	
78	2.52	4.53	6.55	8.57	10.58	12.60	14.61	16.63	18.64	
1.98	0.23	0.42	0.61	0.80	0.98	1.17	1.36	1.54	1.73	
84	2.73	4.91	7.10	9.28	11.46	13.64	15.83	18.01	20.19	
2.13	0.25	0.46	0.66	0.86	1.06	1.27	1.47	1.67	1.88	
90	2.94	5.29	7.64	9.99	12.34	14.69	17.04	19.39	21.75	
2.29	0.27	0.49	0.71	0.93	1.15	1.36	1.58	1.80	2.02	
96	3.15	5.67	8.19	10.70	13.22	15.74	18.26	20.78	23.30	
2.44	0.29	0.53	0.76	0.99	1.23	1.46	1.70	1.93	2.16	
102	3.36	6.04	8.73	11.42	14.10	16.79	19.47	22.16	24.85	
2.59	0.31	0.56	0.81	1.06	1.31	1.56	1.81	2.06	2.31	
108	3.57	6.42	9.27	12.13	14.98	17.84	20.69	23.54	26.40	
2.74	0.33	0.60	0.86	1.13	1.39	1.66	1.92	2.19	2.45	
114	3.78	6.80	9.82	12.84	15.86	18.88	21.91	24.93	27.95	
2.90	0.35	0.63	0.91	1.19	1.47	1.75	2.04	2.32	2.60	
120	3.99	7.18	10.36	13.55	16.74	19.93	23.12	26.31	29.50	
3.05	0.37	0.67	0.96	1.26	1.56	1.85	2.15	2.44	2.74	



This label does not signify AMCA airflow performance certification.

SCHEDULE TYPE:	Page 2 of 3			
PROJECT:	Dimensions are in inches (mm).			
ENGINEER:	DATE	B SERIES	SUPERSEDES	DRAWING NO.
CONTRACTOR:	7 - 6 - 21	1600M	NEW	1609H



**EXTRUDED ALUMINUM STATIONARY HYBRID LOUVER
HIGH VELOCITY WIND-DRIVEN RAIN AND IMPACT RESISTANT
9" (229) DEEP • HORIZONTAL AND VERTICAL BLADE
PERFORMANCE DATA
MODEL: 1609H**

**AIRFLOW/WATER PENETRATION DATA
for 48" x 48" (1219 x 1219) Louver Size**

Free Area %	53%	
Free Area sq. ft. (sq. m.)	8.53 (0.79)	
INTAKE	Free Area Velocity at Point of Beginning Water Penetration at .01 oz./sq. ft. (3 ml/sq. m) (15 min. test duration)	1011 fpm (308 m/min.)
	Air Volume at 1011 fpm	8,624 cfm (4070 l/s)
	Free Area Velocity	
	Pressure Drop @ 1011 fpm	.34 in. w.g. (85 Pa)

NOTE: To minimize water penetration when sizing intake louvers, select a Free Area Velocity that is **below** the beginning point of water penetration.

WIND DRIVEN RAIN PERFORMANCE

Core Ventilation	0	99	198	297	393	494	590	690	789	889	985
Rate in fpm (m/s)	(0.00)	(0.50)	(1.01)	(1.51)	(2.00)	(2.51)	(3.00)	(3.51)	(4.01)	(4.52)	(5.00)
Free Area Ventilation	0	187	374	560	742	932	1113	1302	1489	1677	1858
Rate in fpm (m/s)	(0.00)	(0.95)	(1.90)	(2.84)	(3.77)	(4.73)	(5.65)	(6.61)	(7.56)	(8.52)	(9.44)
Effectiveness Ratio (%)	100	100	100	100	100	100	100	100	100	100	99.9
Penetration Class	A	A	A	A	A	A	A	A	A	A	A

Test was based on a 39.375" x 39.375" (1.0 m x 1.0 m) core area louver tested at a rainfall rate of 3" per hour (76 mm/hour) with a wind velocity of **29 mph (13 m/s)**.

DISCHARGE LOSS COEFFICIENT CLASS (INTAKE): 3. (Discharge Loss Coefficient Classification is as follows: 1=0.4 and above, 2=0.3 to 0.399, 3 = 0.2 to 0.299, 4 = 0.199 and below.)

Core Ventilation	0	96	197	288	396	482	593	691	793	894	988
Rate in fpm (m/s)	(0.00)	(0.49)	(1.00)	(1.46)	(2.01)	(2.45)	(3.01)	(3.51)	(4.03)	(4.54)	(5.02)
Free Area Ventilation	0	181	372	543	747	909	1119	1304	1496	1687	1864
Rate in fpm (m/s)	(0.00)	(0.92)	(1.89)	(2.76)	(3.79)	(4.62)	(5.68)	(6.62)	(7.60)	(8.57)	(9.47)
Effectiveness Ratio (%)	100	100	100	100	100	100	99.8	99.6	99.1	98.5	97.9
Penetration Class	A	A	A	A	A	A	A	A	A	B	B

Test was based on a 39.375" x 39.375" (1.0 m x 1.0 m) core area louver tested at a rainfall rate of 8" per hour (203 mm/hour) with a wind velocity of **50 mph (22 m/s)**.

DISCHARGE LOSS COEFFICIENT CLASS (INTAKE): 3. (Discharge Loss Coefficient Classification is as follows: 1=0.4 and above, 2=0.3 to 0.399, 3 = 0.2 to 0.299, 4 = 0.199 and below.)



Nailor Industries Inc. certifies the Model 1609H shown herein is licensed to bear the AMCA Seal. The ratings shown are based on tests and procedures performed in accordance with AMCA Publication 511 and comply with the requirements of the AMCA Certified Ratings Program. Seal applies to air performance, water penetration and wind driven rain performance ratings.

PRESSURE DROP

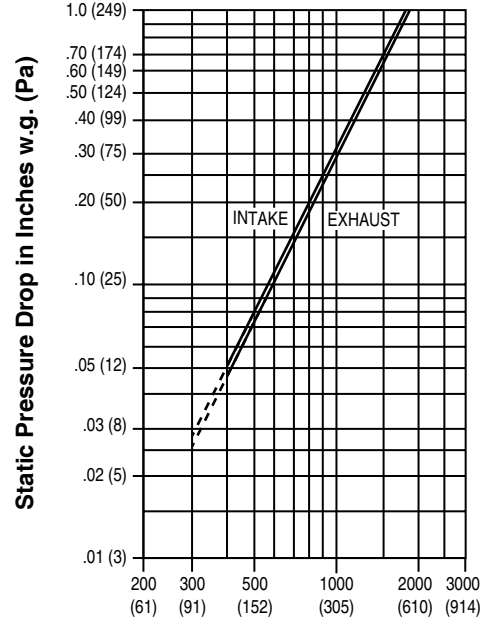

**Air Velocity in Feet (Meters) Per Minute
Through Free Area**

Louver test size: 48" x 48" (1219 x 1219 mm).
Standard air density @ 0.075 lbs/ft³.
Tested to AMCA Fig. 5.5 – 6.5.



**HIGH VELOCITY RAIN
RESISTANT WITH BLADES
FULLY OPEN AND
IMPACT RESISTANT LOUVER
Enhanced Protection Level E**
See www.AMCA.org for all certified or listed products

This label does not signify AMCA airflow performance certification.

Nailor Industries Inc. certifies that the 1609H shown herein is approved to bear the AMCA Listing Label. The ratings shown are based on tests and procedures performed in accordance with AMCA publications and comply with the requirements of the AMCA Listing Label Program. The AMCA Listing Label applies to Wind Borne Debris Impact Resistant Louvers. The AMCA Listing Label applies to High Velocity Wind Driven Rain Resistant Louvers.

SCHEDULE TYPE:				
PROJECT:				
ENGINEER:	DATE	B SERIES	SUPERSEDES	DRAWING NO.
CONTRACTOR:	7 - 6 - 21	1600M	NEW	1609H

Page 3 of 3
Dimensions are in inches (mm).

 Slate Blue **LF01**

 Medium Bronze **LF02**

 Sandstone **LF03**

 Light Gray **LF04**

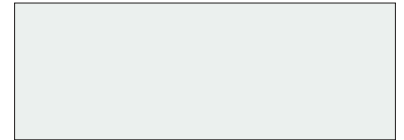
 Charcoal **LF05**

 Bone White **LF06**

 Western Tan **LF07**

 Architectural Bronze **LF08**

 Regal Blue **LF09**

 Forest Green **LF10**

 Surrey Beige **LF11**

 Royal Brown **LF12**

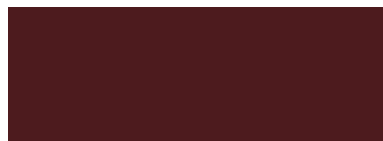
 Barn Red **LF13**

 Burgundy **LF14**

 Clay **LF15**

 Almond **LF16**

 Coastal White **LF17**

 Vista Green **LF18**

 Black **LF19**

 Gloss Black **LF20**

 Campus Green **LF21**

Nailor offers 21 standard paint colors selected for architectural exterior use which meet or exceed AAMA specifications and performance requirements for color retention, chalk resistance, gloss retention, erosion, corrosion and chemical resistance as well as dry film thickness and hardness. Our state-of-the-art powder coat system provides an environment friendly finishing solution with more uniform coverage and coating thickness. The result is an exceptional finish that better resists scratching, fading and general wear. Additional liquid coat facilities for special requirements complete our ability to provide unmatched beauty and durability for any application.

Custom color matching is also available upon request. Contact your local Nailor representative.

Available Finishes

FINISH TYPE	DESCRIPTION	STANDARD WARRANTY
Fluoropolymer Powder Coat AAMA 2605-Superior Finish (AKA: Powdura® 5000, Corafalon® Powder, Interpon® D3000-Fluoromax, IFS 500FP)	"Ultimate" - A next generation hyper durable powder coating, based on FEVE fluoropolymer resins and ceramic pigmentation that the industry has acknowledged as the foundation for superior performance coatings. They provide a hard surface that is resistant to scratching and scuffing, with superior color and gloss retention, when applied to a variety of exterior architectural applications. This technology represents the "ultimate" in environmentally friendly finishes, with Zero-VOC emissions. A superior alternative to traditional 70% Kynar 500® / Hylar 500® PVDF fluoropolymer liquid coatings.	10 years (Consult Nailor for availability of extended warranty)
High Performance Powder Coat AAMA 2604 - High Performance Finish (AKA: Powdura® 4000, Envirocron® Ultra Durable Powder, Dynadure™ 400, Interpon® D2000, IFS 400SD)	"Better" - A high performance polyester powder coating, based on "super durable" resins that utilize infrared reflective pigments, which provides excellent resistance to outdoor weathering. A harder and more environmentally friendly coating than other liquid paint counterparts and with Zero-VOC emissions. A good alternative to 50% Kynar 500® / Hylar 5000® liquid coatings.	5 years
Durable Powder Coat AAMA 2603 - Pigmented Organic Coatings (AKA: Powdura® 3000, Envirocron® Durable Powder, Dynadure™ 300, Interpon® D1000, IFS 300SP)	"Good" - A durable powder coat based on thermosetting polyester resin technology. Provides a good economical combination of physical and chemical resistance properties. Environmentally superior to liquid spray paints and Zero – VOC emissions.	1 year
Clear Anodize 215-R1 AA-M10C22A41 (0.7 mil. min.)	Architectural Class I. Clear, colorless and hard oxide aluminum coating that resists weathering and chemical attack. Recommended for severely corrosive and abrasive atmospheric exposure.	5 years
Clear Anodize 204-R1 AA-M10C22A31 (0.4 - 0.7 mil.)	Architectural Class II. Clear, colorless and hard oxide aluminum coating that resists weathering and chemical attack. Recommended for normal weather exposure.	1 year
Color Anodize AA-M10C22A44 (0.7 mil. min.)	Architectural Class I. "Two-step" aluminum coating process. Following a standard anodizing procedure, a second electrolytic process deposits colored metallic pigments which penetrate the aluminum oxide pores, producing a corrosion resistant, colorfast finish. Available in light, medium, dark bronze and black.	5 years
Prime Coat	Prime coat provides a stable base for painting of louvers in the field. Surface pretreatment includes degreasing and a chemical cleaning before an epoxy prime coat is applied. Finish coat should be field applied as soon as possible for best adhesion, after a thorough cleaning for dust etc. that can contaminate the final finish and cause premature flaking or peeling.	N/A

Paint finish warranties are not applicable to steel products.

Powdura® is a registered trademark of The Sherwin-Williams Company.

Corafalon® and Envirocron® are registered trademarks of PPG Industries Ohio, Inc.

Interpon® is a registered trademark of Akzo Nobel Powder Coatings Ltd.

Kynar 500® is a registered trademark of Arkema, Inc.

Hylar 5000® is a registered trademark of Solvay Solexis, Inc.