

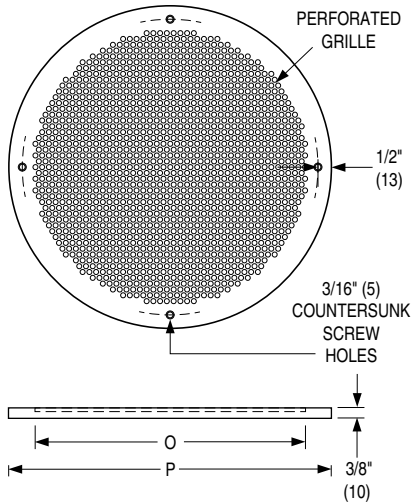

**ROUND PERFORATED GRILLES**  
 STEEL OR ALUMINUM • WALL OR CEILING MOUNT  
 ROUND NECK  
 MODEL: RPG

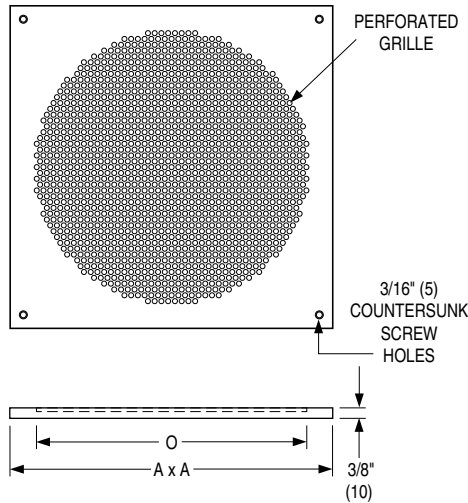

SM Frame  
 (Surface Mount)  
 Round Panel



SMP Frame  
 (Surface Mount)  
 Square Panel

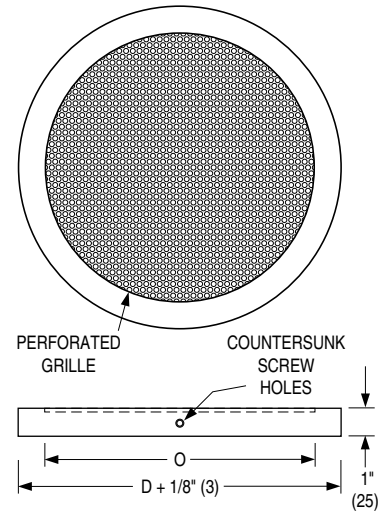

RD Frame  
 (Exposed Round Duct)

Nominal Size	SM Frame		SMP Frame			RD Frame	
	O	P	O	D x D	A x A	O	D
4	4 (102)	6 (152)	4 (102)	4 x 4 (102 x 102)	6 x 6 (152 x 152)	4 (102)	6 (152)
5	5 (127)	8 (203)	5 (127)	5 x 5 (127 x 127)	8 x 8 (203 x 203)	5 (127)	6 (152)
6	6 (152)	8 (203)	6 (152)	6 x 6 (152 x 152)	8 x 8 (203 x 203)	6 (152)	8 (203)
8	8 (203)	10 (254)	8 (203)	8 x 8 (203 x 203)	10 x 10 (254 x 254)	8 (203)	10 (254)
10	10 (254)	12 (305)	10 (254)	10 x 10 (254 x 254)	12 x 12 (305 x 305)	10 (254)	12 (305)
12	12 (305)	14 (356)	12 (305)	12 x 12 (305 x 305)	14 x 14 (356 x 356)	12 (305)	14 (356)
14	14 (356)	16 (406)	14 (356)	14 x 14 (356 x 356)	16 x 16 (406 x 406)	14 (356)	16 (406)
16	16 (406)	18 (457)	16 (406)	16 x 16 (406 x 406)	18 x 18 (457 x 457)	16 (406)	18 (457)

Inches are measured to the nearest 1/16" (2).

**DESCRIPTION:**

1. Material: Heavy gauge steel construction is standard.
2. Model RPG Round Perforated Grille combines versatility and modern esthetics of a flowing circular design with superior performance and high quality. The architectural grilles are designed for applications requiring wall or ceiling mount and are not intended for floor use. They can be used for supply, return or exhaust air.
3. Frame Type SM – Round panel wall or ceiling mount. Mounting screws are provided.  
 Frame Type SMP – Square panel wall or ceiling mount. Mounting screws are provided.  
 Frame Type RD – Exposed round duct work for wall or ceiling mount. Mounts cleanly to exposed duct work.
4. Standard finish is AW Appliance White.

**OPTIONS:**

Frame:

- SM Surface Mount (Wall/Ceiling)
- SMP Surface Mount (Wall/Ceiling) Square Panel
- RD Exposed Round Duct
- ALC Aluminum construction

Finish:

- SP Special.
- Specify: \_\_\_\_\_ .

**SCHEDULE TYPE**

**PROJECT**

**ENGINEER**

**CONTRACTOR**

Dimensions are in inches (mm).

**DATE**

**B SERIES**

**SUPERSEDES**

**DRAWING NO.**

3 - 7 - 19

RPG

11 - 29 - 18

RPG-1

## PERFORMANCE DATA:

### MODEL RPG

Return / Exhaust Airflow Data										
Nom. Size	Opening Size Dia. "O"	Opening Area	Duct Velocity (fpm) Static Pressure (in. w.g.)	400 -0.05	500 -0.08	600 -0.12	700 -0.16	800 -0.21	1000 -0.32	1200 -0.48
4	4	0.087	CFM	35	44	52	61	70	87	105
			Noise Criteria	—	—	—	—	22	28	34
5	5	0.136	CFM	55	68	82	95	109	136	164
			Noise Criteria	—	—	—	21	24	30	36
6	6	0.196	CFM	79	98	118	137	157	196	236
			Noise Criteria	—	—	—	23	26	32	38
8	8	0.349	CFM	140	175	209	244	279	349	419
			Noise Criteria	—	—	20	25	28	34	40
10	10	0.545	CFM	218	273	327	382	436	545	655
			Noise Criteria	—	—	23	27	30	36	42
12	12	0.786	CFM	314	393	471	550	628	786	943
			Noise Criteria	—	—	24	29	32	38	44
14	14	1.069	CFM	428	535	641	748	855	1069	1283
			Noise Criteria	—	20	25	30	33	39	45
16	16	1.396	CFM	559	698	838	978	1117	1396	1676
			Noise Criteria	—	21	26	31	34	40	46

Supply Airflow Data										
Nom. Size	Opening Size Dia. "O"	Opening Area	Duct Velocity (fpm) Static Pressure (in. w.g.)	400 0.06	500 0.09	600 0.13	700 0.17	800 0.22	1000 0.35	1200 0.5
4	4	0.087	CFM	35	44	52	61	70	87	105
			Noise Criteria	—	—	—	—	—	23	28
			Throw	2-4-8	3-6-10	4-8-13	4-10-14	5-11-16	7-12-16	8-13-19
5	5	0.136	CFM	55	68	82	95	109	136	164
			Noise Criteria	—	—	—	—	—	25	30
			Throw	3-6-11	4-9-14	5-10-15	6-12-17	7-14-19	8-15-21	10-17-24
6	6	0.196	CFM	79	98	118	137	157	196	236
			Noise Criteria	—	—	—	—	20	27	32
			Throw	4-9-13	5-11-16	6-13-18	8-15-20	9-16-23	10-18-26	12-21-29
8	8	0.349	CFM	140	175	209	244	279	349	419
			Noise Criteria	—	—	—	—	22	29	34
			Throw	5-11-19	7-13-21	8-15-24	10-19-26	11-22-30	14-25-34	16-28-38
10	10	0.545	CFM	218	273	327	382	436	545	655
			Noise Criteria	—	—	—	20	24	31	36
			Throw	6-12-22	9-16-29	11-20-32	12-24-35	13-27-38	17-31-43	20-34-48
12	12	0.786	CFM	314	393	471	550	628	786	943
			Noise Criteria	—	—	—	22	26	33	37
			Throw	7-14-28	10-19-33	12-24-36	14-27-39	18-31-45	20-34-48	24-40-55
14	14	1.069	CFM	428	535	641	748	855	1069	1283
			Noise Criteria	—	—	—	24	28	34	39
			Throw	8-17-33	12-22-37	15-28-44	16-32-48	18-37-56	23-42-60	28-45-62
16	16	1.396	CFM	559	698	838	978	1117	1396	1676
			Noise Criteria	—	—	20	25	29	35	40
			Throw	9-20-38	14-28-46	17-32-52	20-37-58	23-40-62	27-45-65	30-50-70

#### Performance Notes:

- AIRFLOW CFM:** Standard air density and isothermal conditions.
- STATIC PRESSURE:** Inches of water gauge required.
- NOISE CRITERIA:** Noise Criteria [NC] curve which is not exceeded with a Room Attenuation of 10 dB and based on Sound Power Level, re 10<sup>-12</sup> watts.
- THROW:** Projection distance in feet from outlet at which the maximum velocity from outlet has reduced to 200, 100 and 50 fpm respectively.
- Data derived from tests conducted in accordance with ANSI/ASHRAE Standard 70 – 2006.