



COUNTERBALANCED BACKDRAFT DAMPER
STANDARD PERFORMANCE • MEDIUM DUTY
EXTRUDED ALUMINUM BLADES & FRAME
MODEL: 1370CB

Model 1370CB is a standard performance counterbalanced backdraft damper designed to automatically prevent the backflow of air while allowing for automatic air intake or exhaust/pressure relief in medium duty HVAC applications. Corrosion-resistant extruded aluminum construction highlights the model's features which include a reinforced mitered corner frame that resists racking, and aerodynamic blades that overlap the jambs for maximum weather protection. Extruded PVC blade seals provide quiet closure as well as extra weather protection. Blade linkage is concealed in jamb for low pressure drop and provides smooth operation at system velocities of up to 1500 fpm. Blade mounted counterweights are easily adjusted to desired opening pressure.

STANDARD CONSTRUCTION:

FRAME: 2" (51) wide x .090" (2.3) nominal wall thickness type 6063-T5 extruded aluminum. Corners are mitered.

BLADES: .050" (1.3) nominal wall thickness type 6063-T5 extruded aluminum on 3 5/8" (92) centers.

LINKAGE: Concealed in jamb.

BEARINGS: Synthetic type.

BLADE SEALS: Extruded PVC.

COUNTER-BALANCE: Adjustable, plated steel weights mounted internally (in the airstream).

FINISH: Mill.

MINIMUM SIZE: 6" x 7" (152 x 178).

MAXIMUM SIZE: Single Section: 40" x 48" (1016 x 1219).

Multiple section: Unlimited.

MAXIMUM TEMPERATURE: 200°F (93°C).

MAXIMUM BACK PRESSURE: 3 to 6 in. w.g. (see page 2).

MAX. SYSTEM VELOCITY: 1500 fpm (2500 fpm maximum spot velocity).

MOUNTING:

- VM Vertical mount (standard)
- HMU Horizontal mount (airflow up)
- HMD Horizontal mount (airflow down)

OPTIONS:

- FF Front flange
- FFB Front flange with bolt holes
- FR Rear flange
- FRB Rear flange with bolt holes
- Special features: _____ .

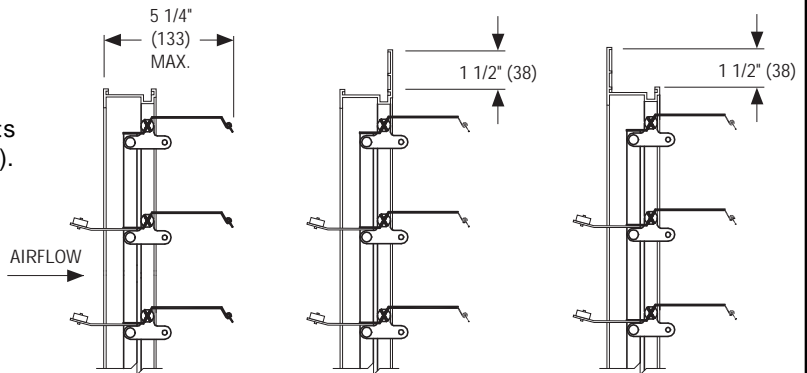
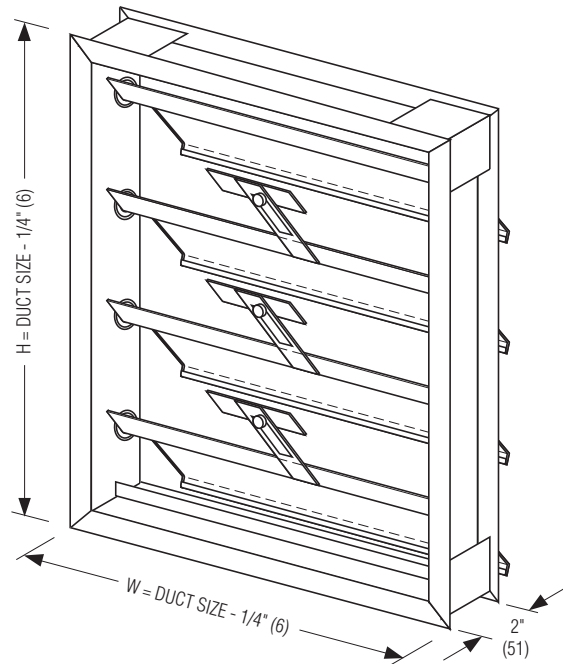

Channel Frame (Duct Mount) (Standard CF)

Front Flange (on discharge side) (Option FF)

Rear Flange (on intake side) (Option FR)

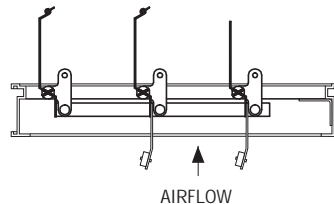

Horizontal Mount – Airflow up (Option HMU) (Available on all frame styles)

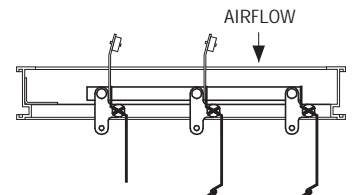

Horizontal Mount – Airflow down (Option HMD) (Available on all frame styles)

SCHEDULE TYPE:

PROJECT:

ENGINEER:

CONTRACTOR:

Page 1 of 2
 Dimensions are in inches (mm).

DATE

B SERIES

SUPERSEDES

DRAWING NO.

1 - 1 - 12

1300

10 - 1 - 04

1370CB



**COUNTERBALANCED BACKDRAFT DAMPER
STANDARD PERFORMANCE • MEDIUM DUTY
EXTRUDED ALUMINUM BLADES & FRAME
PERFORMANCE DATA
MODEL: 1370CB**

PERFORMANCE LIMITATIONS AND LEAKAGE DATA:

Damper Width	Maximum Back Pressure	Maximum System Velocity	Operational Data		Leakage*	
			Blades Begin Opening	Blades Fully Open	% of Maximum Flow	CFM per Sq. Ft.
40" (1016)	3.0" w.g.	1500 fpm	.01" w.g. (2 Pa)	.10" w.g. (25 Pa)	1.00	15
36" (914)	4.0" w.g.	1500 fpm			1.00	15
24" (610)	5.0" w.g.	1500 fpm			1.20	18
12" (305)	6.0" w.g.	1500 fpm			2.67	40

Pressure and velocity limitations shown are guidelines for design purposes. Although ratings are on the conservative side, contact Nailor for requirements beyond limitations shown.

*Leakage data is based upon a pressure differential of 1 in. w.g., tested in accordance with AMCA Standard 500-D.

PRESSURE DROP: SIZE: 36" x 36" (914 x 914)

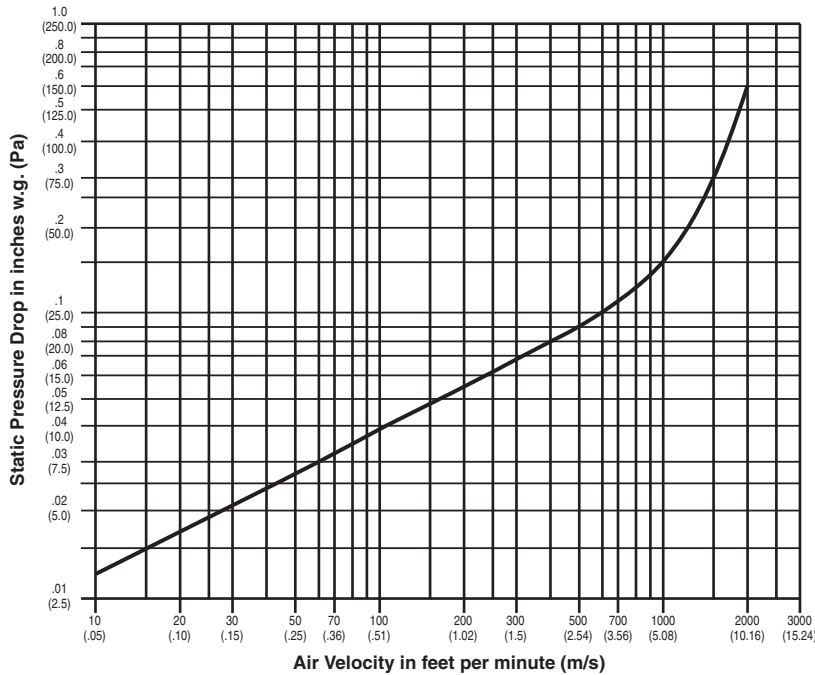

Tested per AMCA Standard 500-D using test set-up Figure 5.5, plenum mounted.

SCHEDULE TYPE:	Page 2 of 2 Dimensions are in inches (mm).			
PROJECT:				
ENGINEER:	DATE	B SERIES	SUPERSEDES	DRAWING NO.
CONTRACTOR:	1 - 1 - 12	1300	10 - 1 - 04	1370CB



COUNTERBALANCED BACKDRAFT DAMPER
HIGH PERFORMANCE • HEAVY DUTY
EXTRUDED ALUMINUM BLADES & FRAME
MODEL: 1380CB

Model 1380CB is a high performance counterbalanced backdraft damper designed to automatically prevent the backflow of air while allowing for automatic air intake or exhaust/pressure relief in medium to heavy duty commercial and light duty industrial HVAC applications. Corrosion-resistant extruded aluminum construction highlights the model's features which include a reinforced mitered corner frame that resists racking, and aerodynamic blades that overlap the jambs for maximum weather protection. Extruded PVC blade seals provide quiet closure as well as extra weather protection. Blade linkage is mounted out of view on the rear of the blades and provides smooth operation at system velocities of up to 2500 fpm. Blade mounted counterweights are easily adjusted to desired opening pressure.

STANDARD CONSTRUCTION:

- FRAME:** 2 1/4" (57) deep channel type, .125" (3.2) nominal wall thickness type 6063-T5 extruded aluminum. Corners are mitered.
- BLADES:** .070" (1.8) nominal wall thickness type 6063-T5 extruded aluminum.
- LINKAGE:** Non-adjustable, face mounted on rear of blades.
- BEARINGS:** Synthetic, sleeve type.
- BLADE SEALS:** Extruded PVC.
- COUNTER-BALANCE:** Adjustable, plated steel weights mounted internally (in the airstream).
- FINISH:** Mill.
- MINIMUM SIZE:** 6" x 10" (152 x 254).
- MAXIMUM SIZE:** Single Section: 48" x 52" (1219 x 1321).
Multiple section: Unlimited.

- MAXIMUM TEMPERATURE:** 200°F (93°C).
- MAXIMUM BACK PRESSURE:** 4 to 16 in. w.g. (see page 2).
- MAX. SYSTEM VELOCITY:** 2500 fpm (3500 fpm maximum spot velocity).

- MOUNTING:**
- VM Vertical mount (standard)
 - HMU Horizontal mount (airflow up)
 - HMD Horizontal mount (airflow down)

- OPTIONS:**
- FF Front flange
 - FFB Front flange with bolt holes
 - FR Rear flange
 - FRB Rear flange with bolt holes
 - Special features: _____ .

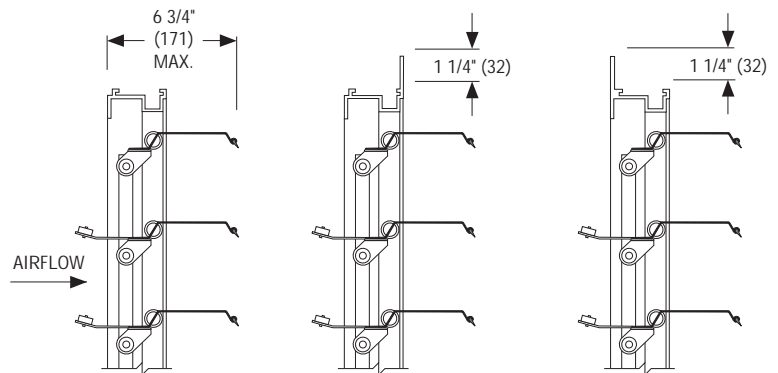
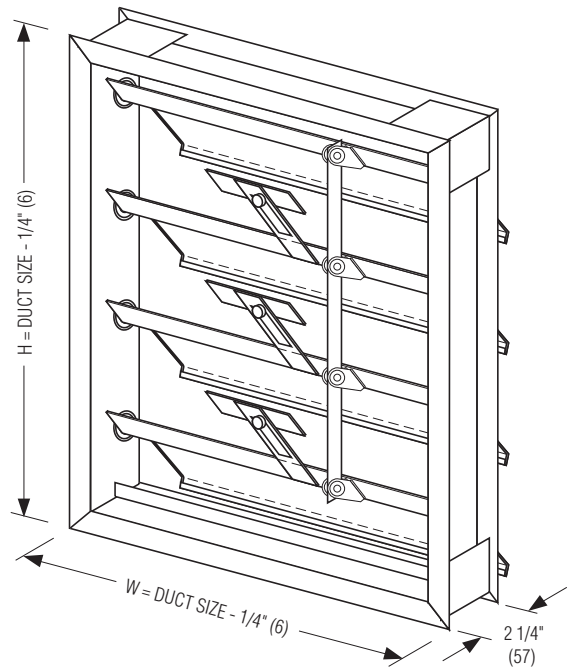

Channel Frame (Duct Mount) (Standard CF)

Front Flange (on discharge side) (Option FF)

Rear Flange (on intake side) (Option FR)

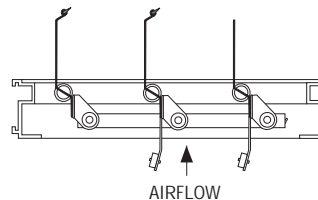

Horizontal Mount – Airflow up (Option HMU) (Available on all frame styles)

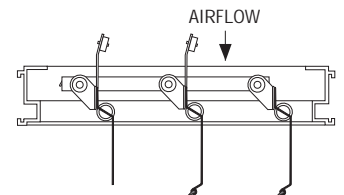

Horizontal Mount – Airflow down (Option HMD) (Available on all frame styles)

SCHEDULE TYPE:	
PROJECT:	
ENGINEER:	
CONTRACTOR:	

Page 1 of 2
 Dimensions are in inches (mm).

DATE	B SERIES	SUPERSEDES	DRAWING NO.
1 - 1 - 12	1300	11 - 8 - 06	1380CB



COUNTERBALANCED BACKDRAFT DAMPER
HIGH PERFORMANCE • HEAVY DUTY
EXTRUDED ALUMINUM BLADES & FRAME
PERFORMANCE DATA
MODEL: 1380CB

PERFORMANCE LIMITATIONS AND LEAKAGE DATA:

Damper Width	Maximum Back Pressure	Maximum System Velocity	Operational Data		Leakage*	
			Blades Begin Opening	Blades Fully Open	% of Maximum Flow	CFM per Sq. Ft.
48" (1219)	4.0" w.g.	2500 fpm	.01" w.g. (2.5 Pa)	.05" w.g. (12.4 Pa)	0.60	15
36" (914)	8.0" w.g.	2500 fpm			0.60	15
24" (610)	12.0" w.g.	2500 fpm			0.72	18
12" (305)	16.0" w.g.	2500 fpm			1.00	25

Pressure and velocity limitations shown are guidelines for design purposes. Although ratings are on the conservative side, contact Nailor for requirements beyond limitations shown.

*Leakage data is based upon a pressure differential of 1 in. w.g., tested in accordance with AMCA Standard 500-D.

PRESSURE DROP: SIZE: 36" x 36" (914 x 914)

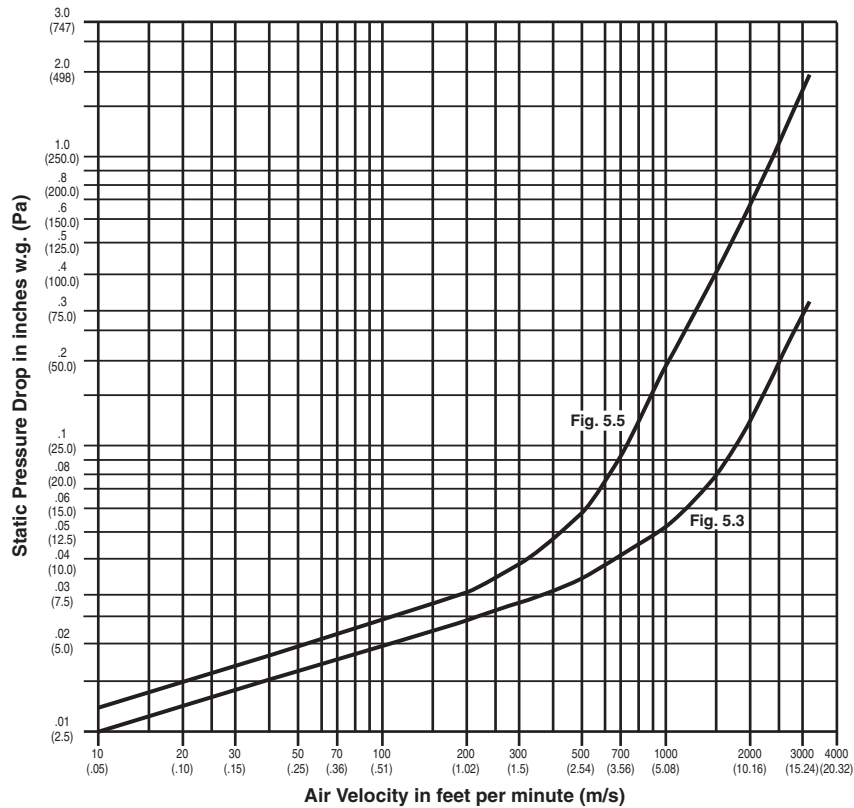

Tested per AMCA Standard 500-D using test set-up Figure 5.3, fully ducted and Figure 5.5, plenum mounted.

SCHEDULE TYPE:	Page 2 of 2 Dimensions are in inches (mm).			
PROJECT:				
ENGINEER:	DATE	B SERIES	SUPERSEDES	DRAWING NO.
CONTRACTOR:	1 - 1 - 12	1300	11 - 8 - 06	1380CB



COUNTERBALANCED BACKDRAFT DAMPER
HIGH PERFORMANCE • HEAVY DUTY
STEEL FRAME • EXTRUDED ALUMINUM BLADES
MODEL: 1390CB

Model 1390CB is a counterbalanced backdraft damper designed for pressure relief to automatically assist in maintaining and limiting desired pressures in medium to heavy duty commercial and light duty industrial HVAC or process air systems. The unique extruded aluminum blade design and fully adjustable counterbalance assembly offer pressure relief at extremely low pressure differentials. The rugged steel mitered corner frame is reinforced to resist racking, and ball bearings provide extreme sensitivity and ultra-smooth operation. Neoprene blade seals provide quiet closure as well as extra weather protection.

STANDARD CONSTRUCTION:

FRAME: 5" x 7/8" x 16 ga. (127 x 22 x 1.6) galvanized steel hat channel with die-formed corner gussets. Low profile (flat top and bottom) for 12" (305) high and under.

BLADES: .070" (1.8) nominal wall thickness Type 6063-T5 extruded aluminum on 5 1/2" (140) centers.

LINKAGE: Non-adjustable, face mounted on rear of blades. Plated steel.

AXLES: 1/2" (13) dia. plated steel.

BEARINGS: Ball bearing type, pressed into frame.

BLADE SEALS: Neoprene.

FINISH: Mill.

COUNTER-BALANCE: CBE Adjustable, externally mounted (standard). Counter-balance assembly may be rotated through 360° to assist opening or closure.

MINIMUM SIZE: 6" x 10" (152 x 254).

MAXIMUM SIZE: Single section: 48" x 60" (1219 x 1524).
 Multiple section: 96" (2413) wide x unlimited height.

MAX. TEMPERATURE: 200°F (93°C).

MAX. PRESSURE: 4 to 16 in. w.g. (see page 2).

MAX. SYSTEM VELOCITY: 2500 fpm (3500 fpm max. spot velocity).

MOUNTING:

- VM Vertical mount (standard)
- HMU Horizontal mount (airflow up)
- HMD Horizontal mount (airflow down)

OPTIONS:

- EAF Extruded aluminum frame. 0.125" (3.2) wall thickness. Type 6063-T5.
- FF Front flange
- FFB Front flange with bolt holes
- FR Rear flange
- FRB Rear flange with bolt holes
- CBI Internal Counterbalance
- Special features: _____

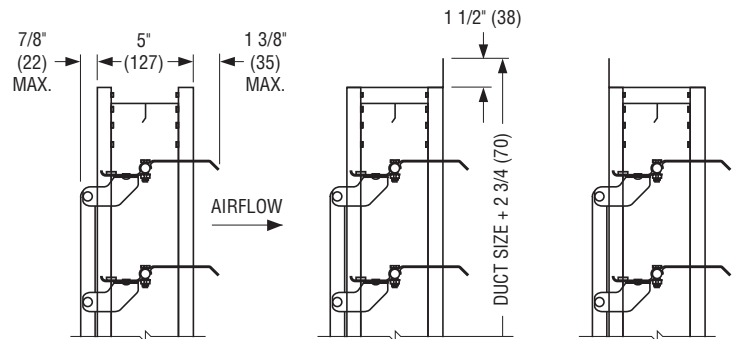
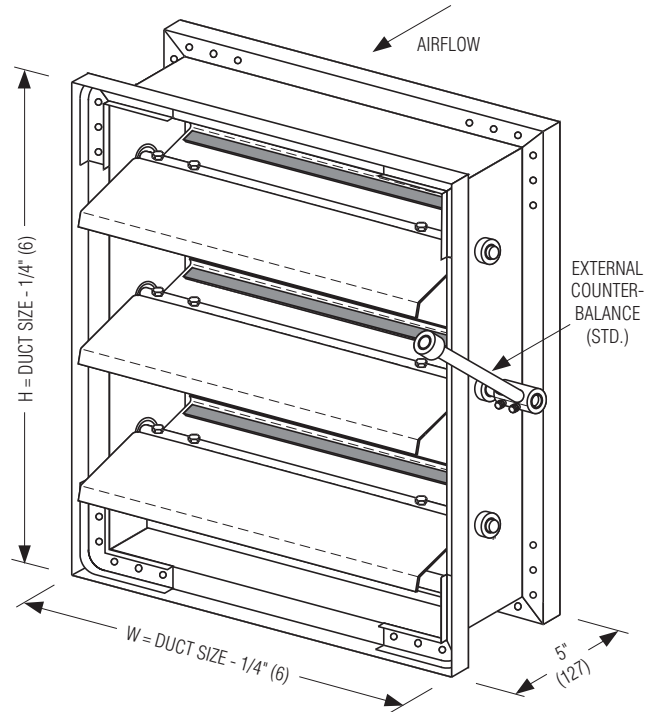
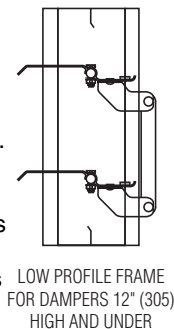

Channel Frame (Duct Mount) (Standard CF)

Front Flange (on discharge side) (Option FF)

Rear Flange (on intake side) (Option FR)

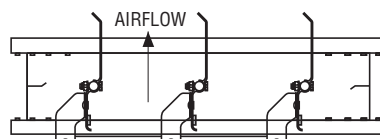

Horizontal Mount – Airflow up (Option HMU)

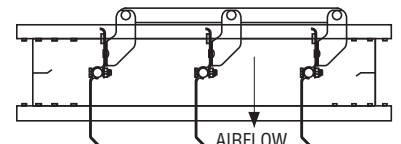

Horizontal Mount – Airflow down (Option HMD)

SCHEDULE TYPE:	
PROJECT:	
ENGINEER:	
CONTRACTOR:	

Page 1 of 2
 Dimensions are in inches (mm).

DATE	B SERIES	SUPERSEDES	DRAWING NO.
2 - 5 - 07	1300	10 - 1 - 04	1390CB



COUNTERBALANCED BACKDRAFT DAMPER
HIGH PERFORMANCE • HEAVY DUTY
PERFORMANCE DATA
MODEL: 1390CB

PERFORMANCE LIMITATIONS AND LEAKAGE DATA:

Damper Width	Maximum Back Pressure	Maximum System Velocity	Operational Data		Leakage*	
			Blades Begin Opening	Blades Fully Open	% of Maximum Flow	CFM per Sq. Ft.
48" (1219)	4.0" w.g.	2500 fpm	.01" w.g. (2.5 Pa)	.06" w.g. (14.9 Pa)	1.48	37.0
36" (914)	8.0" w.g.	2500 fpm			1.68	42.0
24" (610)	12.0" w.g.	2500 fpm			2.04	51.0
12" (305)	16.0" w.g.	2500 fpm			3.36	84.0

Pressure and velocity limitations shown are guidelines for design purposes. Although ratings are on the conservative side, contact Nailor for requirements beyond limitations shown.

*Leakage data is based upon a pressure differential of 1 in. w.g., tested in accordance with AMCA Standard 500-D.

PRESSURE DROP: SIZE: 36" x 36" (914 x 914)

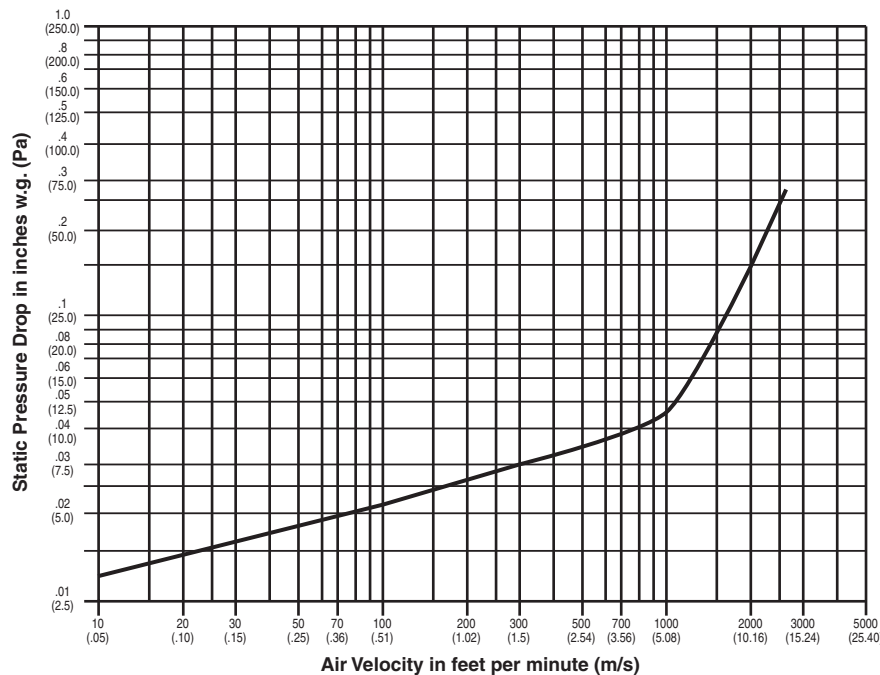

Tested per AMCA Standard 500-D using test set-up figure 5.3, ductwork upstream and downstream.

SCHEDULE TYPE:		Page 2 of 2			
PROJECT:		Dimensions are in inches (mm).			
ENGINEER:	DATE	B SERIES	SUPERSEDES	DRAWING NO.	
CONTRACTOR:	2 - 5 - 07	1300	10 - 1 - 04	1390CB	

RECEIVING/INSPECTION

Upon delivery, inspect shipping containers and dampers carefully. Note any damage on trucker's delivery receipt. Contact the freight company within 24 hours for inspection. Do not install dampers. It is easier to repair on the floor than in the duct.

STORAGE

Store in an orderly manner. Do not pile dampers on each other. Cover with plastic sheeting to protect from excessive moisture, dirt and debris. Avoid unnecessary handling of dampers.

GENERAL INSTALLATION

Handle and lift dampers by frame only. Do not lift by blades or linkage. Use sufficient people and appropriate rigging (if required) to evenly lift multiple section assemblies. Do not drop, drag or twist dampers. Inspect ductwork or opening where damper will be installed for any obstructions and to ensure it is straight and level. Ductwork should be supported to prevent sagging due to damper weight. Ensure dampers are installed completely square and plumb, and that blades are free to operate without binding. Use shims as appropriate between damper frame and duct opening to prevent distortion of the frame by fasteners. Care must be taken to ensure that any fasteners used do not interfere with linkage or blade operation. If applicable, counterbalance assembly must be adjusted for damper to open at desired pressure.

MULTIPLE SECTION ASSEMBLIES

Backdraft dampers larger than single section maximum sizes will be manufactured in equal size sections and must be assembled together in the field. Assemble sections together as shown in Figures 1 and 2 using 1/4" (6) - 20 bolts and locknuts or #10 Tek screws (fasteners by others) spaced on approximately 6" (152) centers. In addition, for single section high dampers install 10" (254) long x 1/16" (1.6) thick aluminum plates on top and bottom, as shown in Figures 1 and 3, using #8 Tek screws or AAP-64 rivets, or similar. For multiple section high dampers install aluminum plates on top, bottom and sides as shown in Figure 2. For larger size dampers not shown follow the same methods. Additional bracing (by others) may be required to support the weight of the assembly and to resist system pressure.

IMPORTANT: BE SURE ALL FASTENERS (BY OTHERS) DO NOT INTERFERE WITH DAMPER LINKAGE AND BLADE OPERATION!

FIGURE 1:

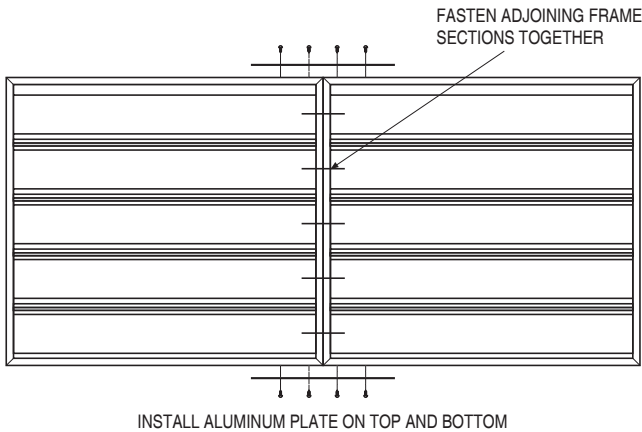
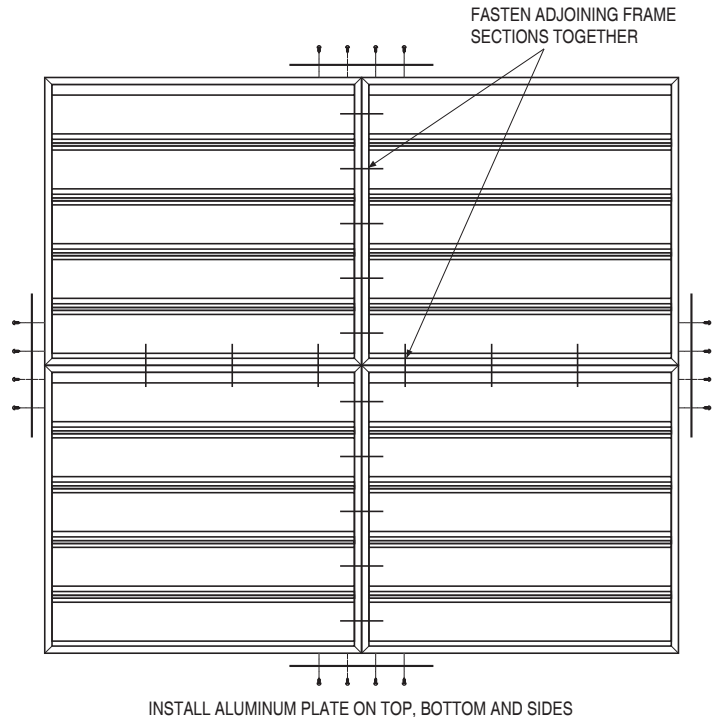
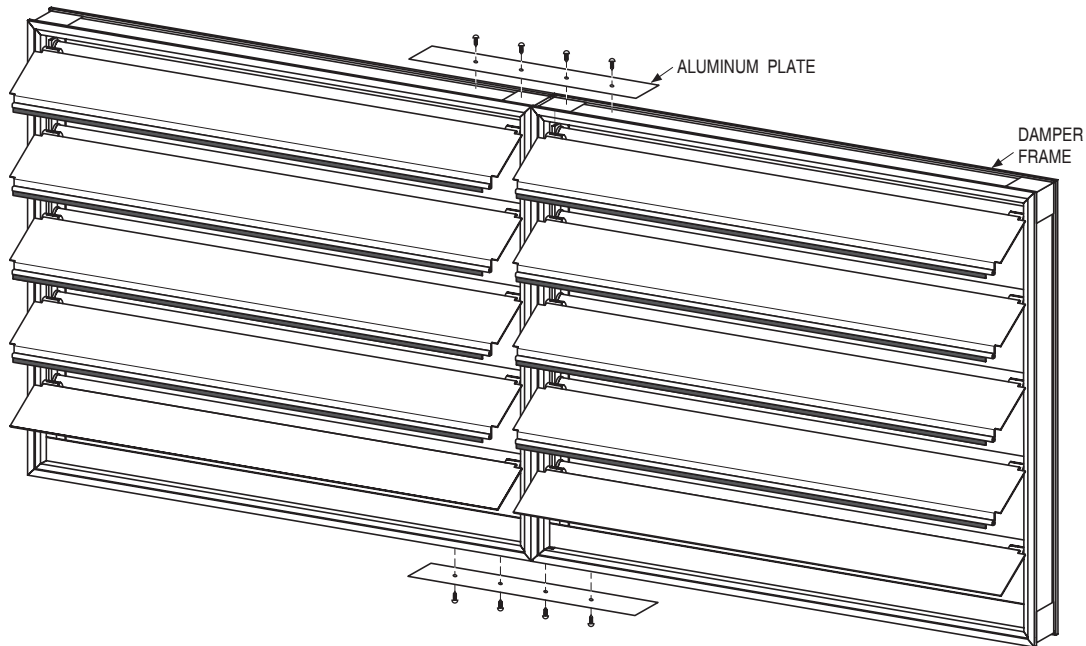

FIGURE 2:



IMPORTANT: BE SURE ALL FASTENERS (BY OTHERS) DO NOT INTERFERE WITH DAMPER LINKAGE AND BLADE OPERATION!

FIGURE 3:



COUNTERBALANCE ADJUSTMENT

Nailor counterbalanced backdraft dampers can be adjusted to open at a specific pressure. Before making adjustments, be sure that the damper is installed square and plumb and that the blades move freely. Damper should be fully closed under conditions of no airflow. Opening pressure can be adjusted by sliding counterbalance weights (further from blade to further assist opening). If full adjustment has been made and blades still don't open fully then more weight should be added. Repeat process if necessary to achieve final positioning.

MAINTENANCE

Dampers should be inspected at least once every two years, depending upon operating conditions, as part of a regular maintenance program. Wipe any dirt, dust etc. from blades and linkage. Lightly lubricate linkage and other moving parts with a dry type lube such as Moli-Spray Oil #3. Cycle damper by hand to ensure all blades and linkages move freely.

Dimensions are in inches (mm).

Page 2 of 2



Houston, Texas
Tel: 281-590-1172
Fax: 281-590-3086

Las Vegas, Nevada
Tel: 702-648-5400
Fax: 702-638-0400

Toronto, Canada
Tel: 416-744-3300
Fax: 416-744-3360

Calgary, Canada
Tel: 403-279-8619
Fax: 403-279-5035