



**COUNTERBALANCED BACKDRAFT DAMPER**  
**STANDARD PERFORMANCE • MEDIUM DUTY**  
**EXTRUDED ALUMINUM BLADES & FRAME**  
**MODEL: 1370CB**

Model 1370CB is a standard performance counterbalanced backdraft damper designed to automatically prevent the backflow of air while allowing for automatic air intake or exhaust/pressure relief in medium duty HVAC applications. Corrosion-resistant extruded aluminum construction highlights the model's features which include a reinforced mitered corner frame that resists racking, and aerodynamic blades that overlap the jambs for maximum weather protection. Extruded PVC blade seals provide quiet closure as well as extra weather protection. Blade linkage is concealed in jamb for low pressure drop and provides smooth operation at system velocities of up to 1500 fpm. Blade mounted counterweights are easily adjusted to desired opening pressure.

**STANDARD CONSTRUCTION:**

- Frame:** 2" (51) wide x .090" (2.3) nominal wall thickness type 6063-T5 extruded aluminum. Corners are mitered.
- Blades:** .050" (1.3) nominal wall thickness type 6063-T5 extruded aluminum on 3 5/8" (92) centers.
- Linkage:** Concealed in jamb.
- Bearings:** Synthetic type.
- Blade Seals:** Extruded PVC.
- Counterbalance:** Adjustable, plated steel weights mounted internally (in the airstream).
- Finish:** Mill.
- Minimum Size:** 6" x 7" (152 x 178).
- Maximum Size:** Single Section: 40" x 48" (1016 x 1219).  
Multiple section: Unlimited.
- Maximum Temperature:** 200°F (93°C).
- Maximum Back Pressure:** 3 to 6 in. w.g. (see page 2).
- Max. System Velocity:** 2000 fpm (2500 fpm maximum spot velocity).

**MOUNTING:**

- VM** Vertical mount (standard)
- HMU** Horizontal mount (airflow up)
- HMD** Horizontal mount (airflow down)

**OPTIONS:**

- FF** Front flange
- FFB** Front flange with bolt holes
- FR** Rear flange
- FRB** Rear flange with bolt holes
- Special features: \_\_\_\_\_

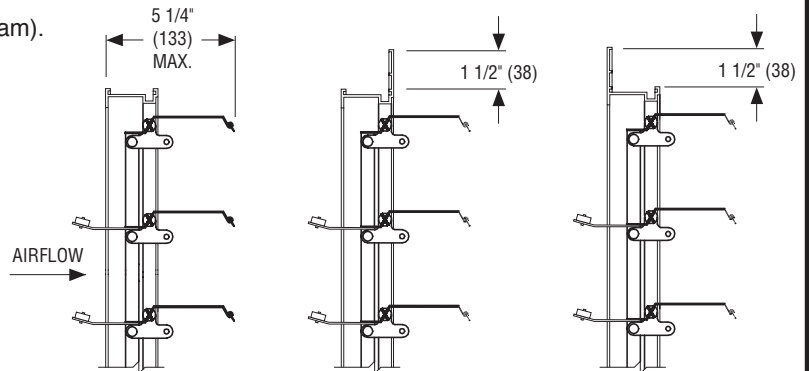
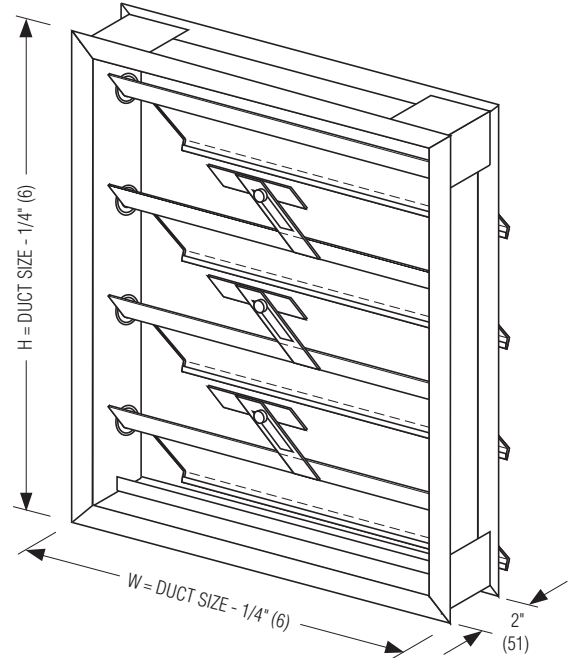

**Channel Frame (Duct Mount) (Standard CF)**

**Front Flange (on discharge side) (Option FF)**

**Rear Flange (on intake side) (Option FR)**

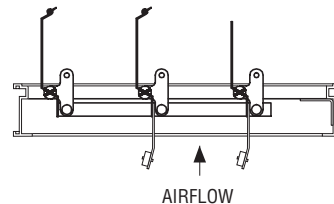

**Horizontal Mount – Airflow up (Option HMU) (Available on all frame styles)**

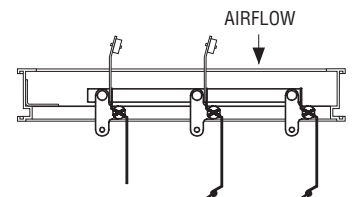

**Horizontal Mount – Airflow down (Option HMD) (Available on all frame styles)**

<b>SCHEDULE TYPE:</b>	Page 1 of 2			
<b>PROJECT:</b>	Dimensions are in inches (mm).			
<b>ENGINEER:</b>	<b>DATE</b>	<b>B SERIES</b>	<b>SUPERSEDES</b>	<b>DRAWING NO.</b>
<b>CONTRACTOR:</b>	6 - 15 - 26	1300	12 - 17 - 25	1370CB



**COUNTERBALANCED BACKDRAFT DAMPER**  
**STANDARD PERFORMANCE • MEDIUM DUTY**  
**EXTRUDED ALUMINUM BLADES & FRAME**  
**PERFORMANCE DATA**  
**MODEL: 1370CB**

**PERFORMANCE LIMITATIONS AND LEAKAGE DATA:**

Damper Width	Maximum Back Pressure	Maximum System Velocity	Operational Data		Leakage*	
			Blades Begin Opening	Blades Fully Open	% of Maximum Flow	CFM per Sq. Ft.
40" (1016)	3.0" w.g.	2000 fpm	.01" w.g. (2 Pa)	.10" w.g. (25 Pa)	1.00	15
36" (914)	4.0" w.g.	2000 fpm			1.00	15
24" (610)	5.0" w.g.	2000 fpm			1.20	18
12" (305)	6.0" w.g.	2000 fpm			2.67	40

Pressure and velocity limitations shown are guidelines for design purposes. Although ratings are on the conservative side, contact Nailor for requirements beyond limitations shown.

\*Leakage data is based upon a pressure differential of 1 in. w.g., tested in accordance with AMCA Standard 500-D.

**PRESSURE DROP: SIZE: 36" x 36" (914 x 914)**

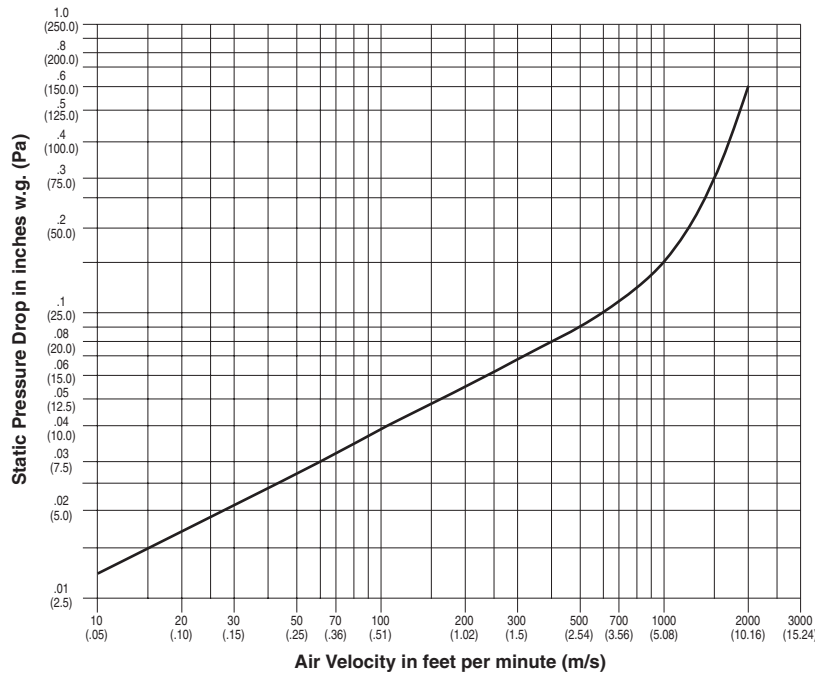

Tested per AMCA Standard 500-D using test set-up Figure 5.5, plenum mounted.

<b>SCHEDULE TYPE:</b>	Page 2 of 2			
<b>PROJECT:</b>	Dimensions are in inches (mm).			
<b>ENGINEER:</b>	<b>DATE</b>	<b>B SERIES</b>	<b>SUPERSEDES</b>	<b>DRAWING NO.</b>
<b>CONTRACTOR:</b>	6 - 15 - 26	1300	12 - 17 - 25	1370CB



**COUNTERBALANCED BACKDRAFT DAMPER**  
 HIGH PERFORMANCE • HEAVY DUTY  
 EXTRUDED ALUMINUM BLADES & FRAME  
**MODEL: 1380CB**

Model 1380CB is a high performance counterbalanced backdraft damper designed to automatically prevent the backflow of air while allowing for automatic air intake or exhaust/pressure relief in medium to heavy duty commercial and light duty industrial HVAC applications. Corrosion-resistant extruded aluminum construction highlights the model's features which include a reinforced mitered corner frame that resists racking, and aerodynamic blades that overlap the jambs for maximum weather protection. Extruded PVC blade seals provide quiet closure as well as extra weather protection. Blade linkage is mounted out of view on the rear of the blades and provides smooth operation at system velocities of up to 2500 fpm. Blade mounted counterweights are easily adjusted to desired opening pressure.

**STANDARD CONSTRUCTION:**

- Frame:** 2 1/4" (57) deep channel type, .125" (3.2) nominal wall thickness type 6063-T5 extruded aluminum. Corners are mitered.
- Blades:** .070" (1.8) nominal wall thickness type 6063-T5 extruded aluminum.
- Linkage:** Non-adjustable, face mounted on rear of blades.
- Bearings:** Synthetic, sleeve type.
- Blade Seals:** Extruded PVC.
- Counterbalance:** Adjustable, plated steel weights mounted internally (in the airstream).
- Finish:** Mill.
- Minimum Size:** 6" x 10" (152 x 254).
- Maximum Size:** Single Section: 48" x 72" (1219 x 1829).  
Multiple section: Unlimited.
- Maximum Temperature:** 200°F (93°C).
- Maximum Back Pressure:** 4 to 16 in. w.g. (see page 2).
- Max. System Velocity:** 3000 fpm (3500 fpm maximum spot velocity).

**MOUNTING:**

- VM** Vertical mount (standard)
- HMU** Horizontal mount (airflow up)
- HMD** Horizontal mount (airflow down)

**OPTIONS:**

- FF** Front flange
- FFB** Front flange with bolt holes
- FR** Rear flange
- FRB** Rear flange with bolt holes
- Special features: \_\_\_\_\_ .

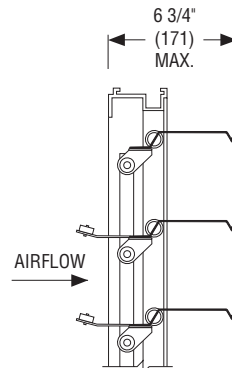
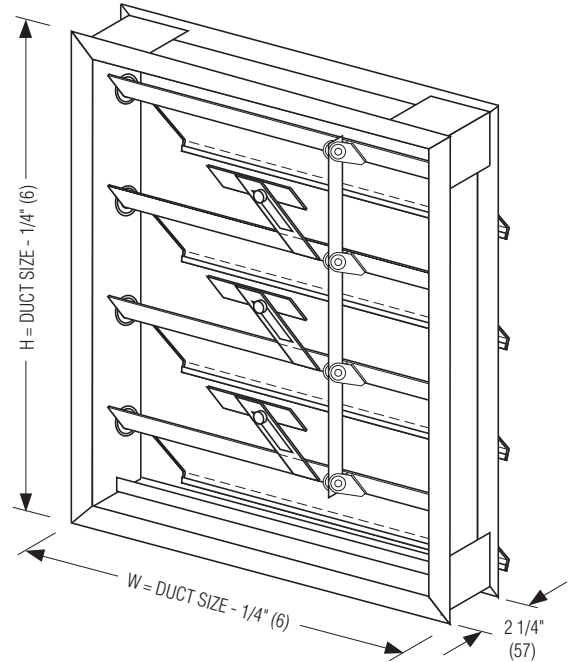

**Channel Frame (Duct Mount) (Standard CF)**

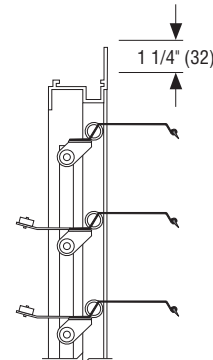

**Front Flange (on discharge side) (Option FF)**

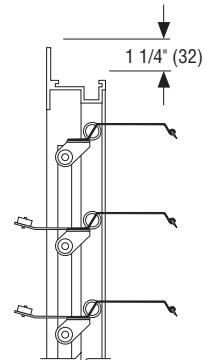

**Rear Flange (on intake side) (Option FR)**

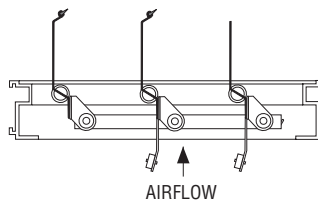

**Horizontal Mount - Airflow up (Option HMU) (Available on all frame styles)**

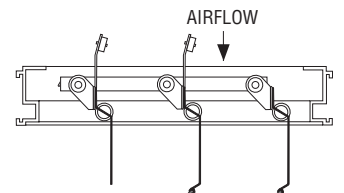

**Horizontal Mount - Airflow down (Option HMD) (Available on all frame styles)**

**SCHEDULE TYPE:**

**PROJECT:**

**ENGINEER:**

**CONTRACTOR:**

Page 1 of 2  
 Dimensions are in inches (mm).

DATE	B SERIES	SUPERSEDES	DRAWING NO.
6 - 15 - 26	1300	12 - 19 - 25	1380CB



**COUNTERBALANCED BACKDRAFT DAMPER**  
 HIGH PERFORMANCE • HEAVY DUTY  
 EXTRUDED ALUMINUM BLADES & FRAME  
**PERFORMANCE DATA**  
**MODEL: 1380CB**

**PERFORMANCE LIMITATIONS AND LEAKAGE DATA:**

Damper Width	Maximum Back Pressure	Maximum System Velocity	Operational Data		Leakage*	
			Blades Begin Opening	Blades Fully Open	% of Maximum	CFM per Sq. Ft.
48" (1219)	4.0" w.g.	3000 fpm	.01" w.g. (2.5 Pa)	.05" w.g. (12.4 Pa)	0.60	15
36" (914)	8.0" w.g.	3000 fpm			0.60	15
24" (610)	12.0" w.g.	3000 fpm			0.72	18
12" (305)	16.0" w.g.	3000 fpm			1.00	25

Pressure and velocity limitations shown are guidelines for design purposes. Although ratings are on the conservative side, contact Nailor for requirements beyond limitations shown.

\*Leakage data is based upon a pressure differential of 1 in. w.g., tested in accordance with AMCA Standard 500-D.

**PRESSURE DROP: SIZE: 36" x 36" (914 x 914)**

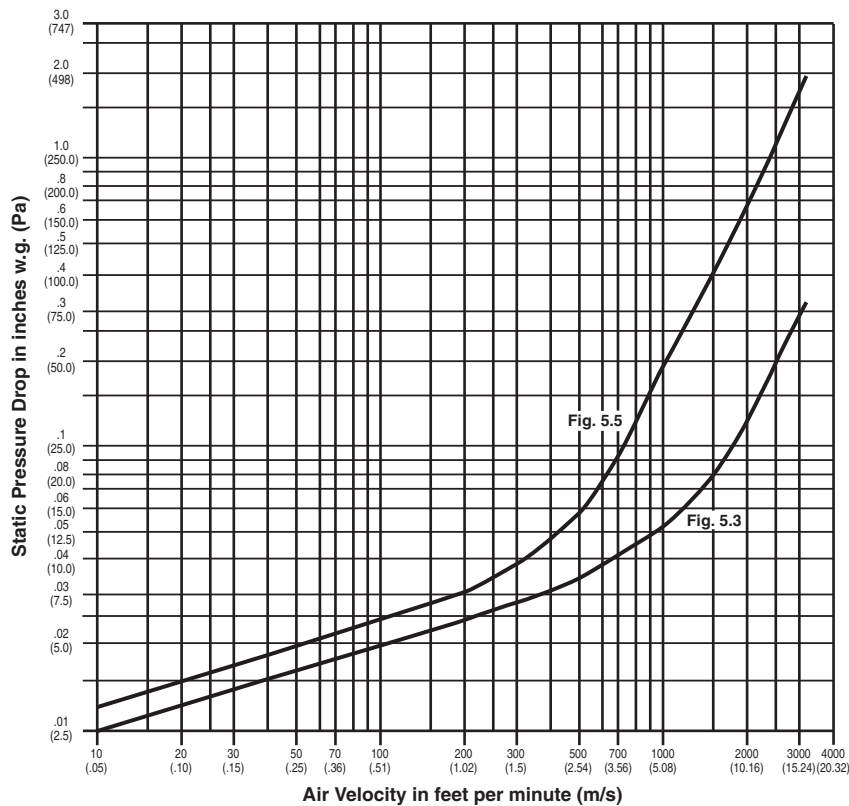

Tested per AMCA Standard 500-D using test set-up Figure 5.3, fully ducted and Figure 5.5, plenum mounted.

<b>SCHEDULE TYPE:</b>	Page 2 of 2			
<b>PROJECT:</b>	Dimensions are in inches (mm).			
<b>ENGINEER:</b>	<b>DATE</b>	<b>B SERIES</b>	<b>SUPERSEDES</b>	<b>DRAWING NO.</b>
<b>CONTRACTOR:</b>	6 - 15 - 26	1300	12 - 19 - 25	1380CB



**COUNTERBALANCED BACKDRAFT DAMPER**  
 HIGH PERFORMANCE • HEAVY DUTY  
 STEEL FRAME • EXTRUDED ALUMINUM BLADES  
 MODEL: 1390CB

Model 1390CB is a counterbalanced backdraft damper designed for pressure relief to automatically assist in maintaining and limiting desired pressures in medium to heavy duty commercial and light duty industrial HVAC or process air systems. The unique extruded aluminum blade design and fully adjustable counterbalance assembly offer pressure relief at extremely low pressure differentials. The rugged steel mitered corner frame is reinforced to resist racking, and ball bearings provide extreme sensitivity and ultra-smooth operation. Neoprene blade seals provide quiet closure as well as extra weather protection.

**STANDARD CONSTRUCTION:**

- Frame:** 5" x 7/8" x 16 ga. (127 x 22 x 1.6) galvanized steel hat channel with die-formed corner gussets. Low profile (flat top and bottom) for 12" (305) high and under.
- Blades:** .070" (1.8) nominal wall thickness Type 6063-T5 extruded aluminum on 5 1/2" (140) centers.
- Linkage:** Non-adjustable, face mounted on rear of blades. Plated steel.
- Axles:** 1/2" (13) dia. plated steel.
- Bearings:** Ball bearing type, pressed into frame.
- Blade Seals:** Neoprene.
- Finish:** Mill.
- Counter-Balance:** CBE Adjustable, externally mounted (standard). Counter-balance assembly may be rotated through 360° to assist opening or closure.
- Minimum Size:** 6" x 10" (152 x 254).
- Maximum Size:** Single section: 48" x 60" (1219 x 1524).  
Multiple section: 96" (2413) wide x unlimited height.
- Max Temp:** 200°F (93°C).
- Max Pressure:** 4 to 16 in. w.g. (see page 2).
- Max Velocity:** 3000 fpm (3500 fpm max. spot velocity).

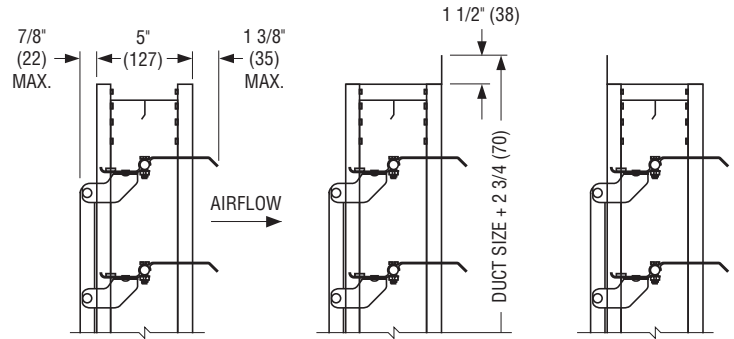
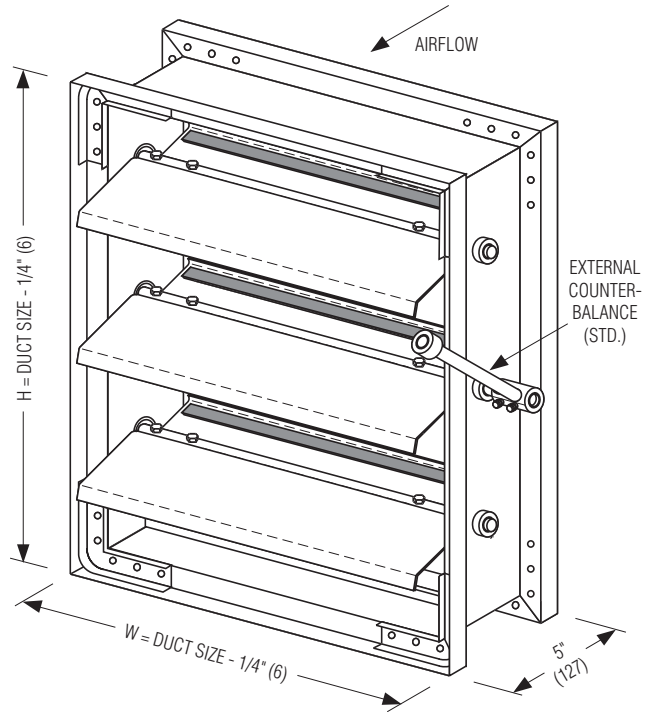

**MOUNTING:**

- VM** Vertical mount (standard)
- HMU** Horizontal mount (airflow up)
- HMD** Horizontal mount (airflow down)

**OPTIONS:**

- EAF** Extruded aluminum frame. 0.125" (3.2) wall thickness. Type 6063-T5.
- FF** Front flange
- FFB** Front flange with bolt holes
- FR** Rear flange
- FRB** Rear flange with bolt holes
- CBI** Internal Counterbalance
- Special features:** \_\_\_\_\_

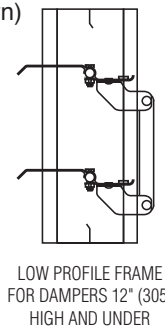

**Channel Frame (Duct Mount) (Standard CF)**

**Front Flange (on discharge side) (Option FF)**

**Rear Flange (on intake side) (Option FR)**

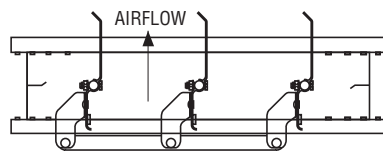

**Horizontal Mount – Airflow up (Option HMU)**

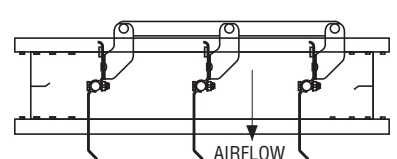

**Horizontal Mount – Airflow down (Option HMD)**

**SCHEDULE TYPE:**

**PROJECT:**

**ENGINEER:**

**CONTRACTOR:**

Page 1 of 2  
 Dimensions are in inches (mm).

DATE	B SERIES	SUPERSEDES	DRAWING NO.
6 - 15 - 26	1300	12 - 17 - 25	1390CB



**COUNTERBALANCED BACKDRAFT DAMPER**  
 HIGH PERFORMANCE • HEAVY DUTY  
**PERFORMANCE DATA**  
 MODEL: 1390CB

**PERFORMANCE LIMITATIONS AND LEAKAGE DATA:**

Damper Width	Maximum Back Pressure	Maximum System Velocity	Operational Data		Leakage*	
			Blades Begin Opening	Blades Fully Open	% of Maximum Flow	CFM per Sq. Ft.
48" (1219)	4.0" w.g.	3000 fpm	.01" w.g. (2.5 Pa)	.06" w.g. (14.9 Pa)	1.48	37
36" (914)	8.0" w.g.	3000 fpm			1.68	42
24" (610)	12.0" w.g.	3000 fpm			2.04	51
12" (305)	16.0" w.g.	3000 fpm			3.36	84

Pressure and velocity limitations shown are guidelines for design purposes. Although ratings are on the conservative side, contact Nailor for requirements beyond limitations shown.

\*Leakage data is based upon a pressure differential of 1 in. w.g., tested in accordance with AMCA Standard 500-D.

**PRESSURE DROP: SIZE: 36" x 36" (914 x 914)**

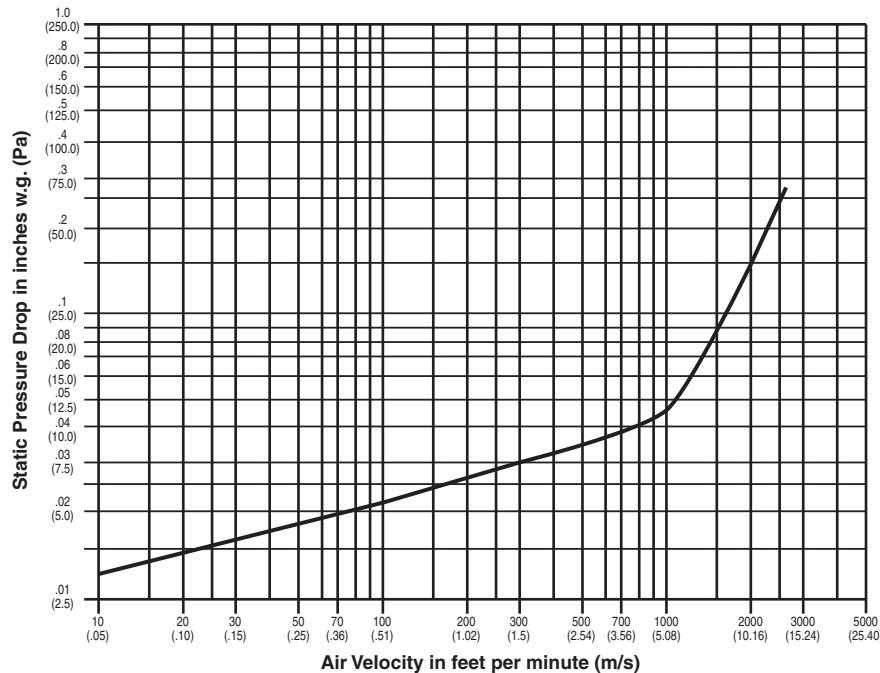

Tested per AMCA Standard 500-D using test set-up figure 5.3, ductwork upstream and downstream.

<b>SCHEDULE TYPE:</b>	Page 2 of 2			
<b>PROJECT:</b>	Dimensions are in inches (mm).			
<b>ENGINEER:</b>	<b>DATE</b>	<b>B SERIES</b>	<b>SUPERSEDES</b>	<b>DRAWING NO.</b>
<b>CONTRACTOR:</b>	6 - 15 - 26	1300	12 - 17 - 25	1390CB