

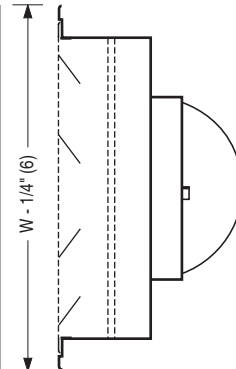

RADIAL PATTERN DIFFUSER
ALUMINUM • FLUSH FACE
MODELS: 92FRP-1AL 90° PATTERN
92FRP-2AL 180° PATTERN

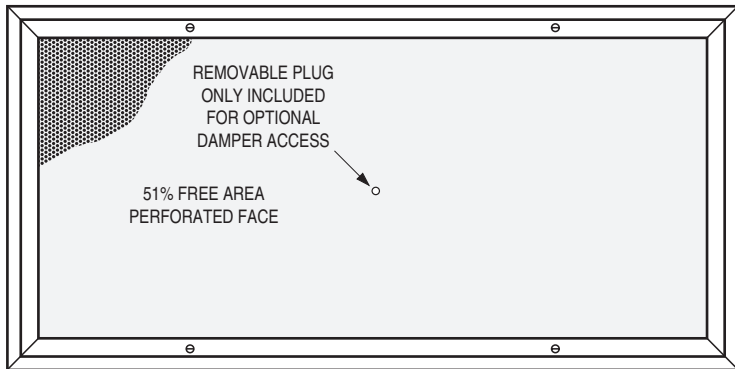

TYPE S Surface Mount Detail

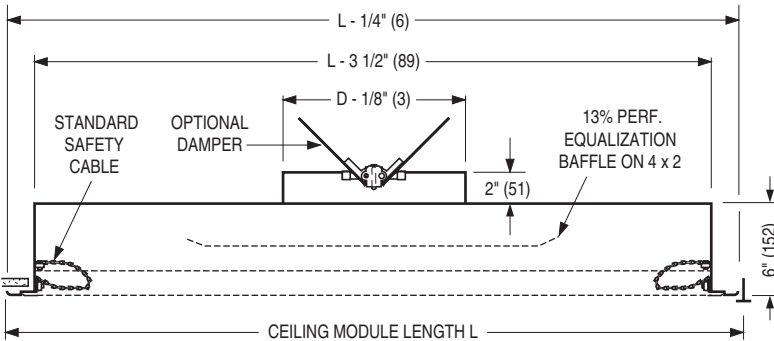
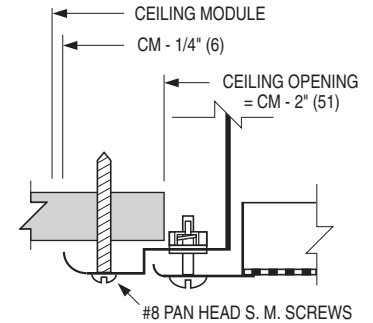

TYPE L* Lay-in T-Bar Detail

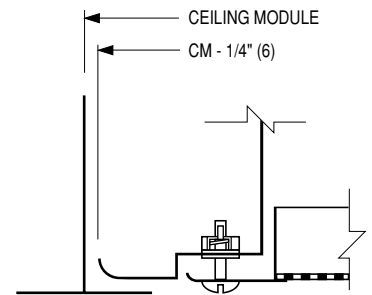

Note: 92FRP-2AL pattern controllers illustrated.

*Compatible with all T-Bars up to 2" (51) wide.

Ceiling Module Sizes L x W & Nominal Round Duct Sizes D

L x W	Imperial Modules (inches)		24 x 24	48 x 24
	Metric Modules (mm)		600 x 600	1200 x 600
	Duct Size D	(inches)	8, 10	10, 12
		(mm)	203, 254	254, 305

DESCRIPTION:

The Model 92FRP Series has been designed to produce a radial air pattern utilizing a non-intrusive flush perforated face design. The 92FRP-1AL produces a one-way 90° pattern. The 92FRP-2AL produces a hemispherical 180° pattern. Suitable for pharmaceutical manufacturing, biotechnology research, animal labs, food processing and other clean applications where high airflows with short throws are required.

The design features solid baffles behind a 51% free area perforated face, which maximizes capacity while allowing low initial face velocities. The radial air pattern flushes the critical area underneath the diffuser with large volumes of clean conditioned air, minimizing entrainment and hence mixing with contaminated air.

CONSTRUCTION:

1. Extruded aluminum frame and aluminum perforated face with 3/16" (5) dia. holes on 1/4" (6) staggered centers (51% free area). The face plate is removable for cleaning and is secured by 1/4 turn fasteners.
2. Aluminum backpan and pattern controllers.
3. Standard safety cables prevent accidental dropping of removable face.
4. Standard finish is AW Appliance White. BA Appliance White Face/Black backpan and other finishes are available.

OPTIONS:

- BD** Butterfly damper, coated steel, AW Appliance White finish.
- EX05** 0.5" (13) External Foil-Back Fiberglass Insulation.
- EX15** 1.5" (38) External Foil-Back Fiberglass Insulation, R-4.2.
- SSF** Type 304 Stainless Steel Perforated Face.
- Other** _____ .

ACCESSORIES:

- DFA** Aluminum Drywall/Plaster Frame. Provides simple easy installation of Type L in hard ceilings. (See submittal dwg. ACC-DFA). Ordered separately.

SCHEDULE TYPE:

PROJECT:

ENGINEER:

CONTRACTOR:

Dimensions are in inches (mm).

DATE	B SERIES	SUPERSEDES	DRAWING NO.
5 - 11 - 22	9200	10 - 29 - 15	92FRP-AL