

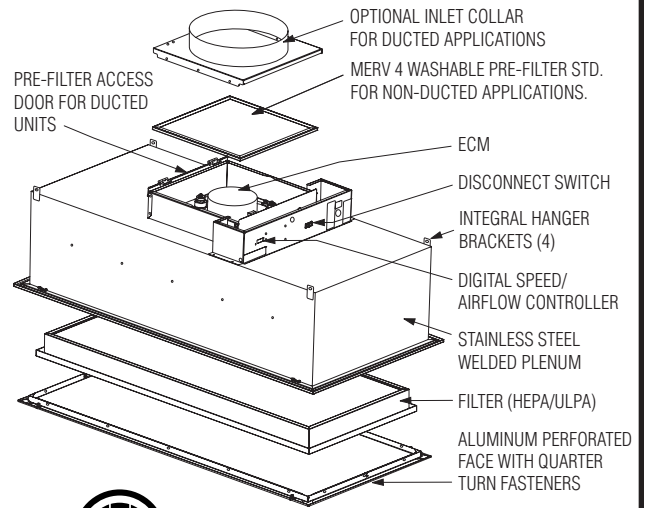

FAN FILTER DIFFUSER
CRITICAL ENVIRONMENT APPLICATIONS
ALUMINUM • ECM • HEPA OR ULPA FILTER
MODEL: 92FFD

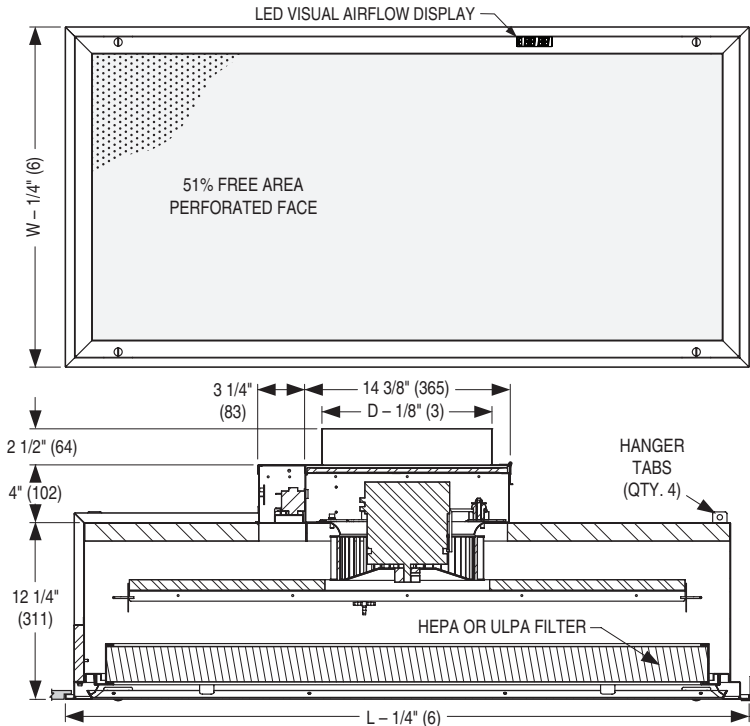

TYPE S Surface Mount Detail

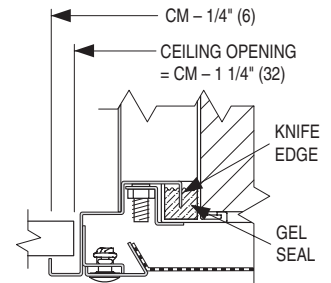

TYPE L Lay-in T-Bar Detail

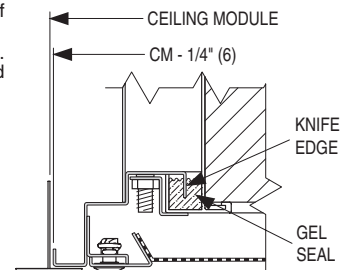

* COMPATIBLE WITH T-BARS UP TO 1 1/2" (38) WIDE

(Standard) 1 1/2" (38) wide.

L20 (Optional) 2" (51) wide.

SPP Standard

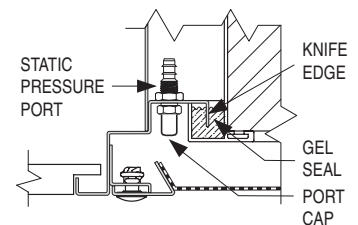

Ceiling Module Sizes

Ceiling Module Size		Inlet Size	
Imperial (inches)	Metric (mm)	Inches	(mm)
Standard (Ductless)			
24 x 24	600 x 600	14 x 14	356 x 356
36 x 24	900 x 600	Optional (Ducted)	
48 x 24	1200 x 600		
		10, 12, 14	254, 305, 356

DESCRIPTION:

Nailor 92FFD Series Fan Filter Diffusers are designed to supply HEPA/ULPA filtered air to a cleanroom environment. The units are intended for use in cleanroom applications such as microelectronics, pharmaceutical, biotechnology as well as aerospace manufacturing/assembly and laser/optic industries.

All 92FFD series plenums consist of a robotically welded plenum and fan/motor assembly to ensure a repeatable, rigid, clean and near leak free design, meeting the most stringent of current leak tests.

ECM technology provides an ultra-energy efficient design with the ability to precisely set a constant air volume. As filter loading increases fan external static pressure, the ECM will compensate to maintain set airflow.

Filters are secured within the plenum against a continuous knife edge that contacts the gel channel of the filter, providing a leak proof seal. Filters are protected by a perforated face, room-side-removable via quarter turn fasteners.

STANDARD FEATURES:

1. Aluminum frame and perforated face with 3/16" (5) dia. holes on 60° 1/4" (6) staggered centers (51% free area). The face plate is removable for cleaning, filter replacement and is secured by 1/4 turn fasteners.
2. 304 Stainless Steel fully welded plenum.
3. Internal Urethane Foam insulation to reduce sound levels.
4. Heavy duty hanger brackets.
5. LED fan operation indicator (on during normal operation).
6. AW Appliance White finish.
7. Two Stainless Steel safety cables to prevent accidental dropping of removable face.
8. High Efficiency ECM for precise constant airflow and field balancing. Available: 120V/1PH/60Hz, 208V/1PH/60Hz, 240V/1PH/60Hz and 277V/1PH/60Hz.
9. Digital speed controller with airflow readout.
10. Face accessible SPP.
11. HEPA filter (99.99% on 0.3 µm).
12. PAO scan tested to IEST RP Standards.
13. QF Toggle disconnect switch.
14. ETL Listed and Tested to UL 507 Standard.
15. Face adjustable airflow control.

OPTIONS:

- UL ULPA Filter (99.9995% on 0.12 µm).
- FBO Filter by others.
- CF Constant Flow EC Motor Program is standard (default).
- CT Constant Torque EC Motor Program is optional.
- RMB Room side removable motor/blower.
- RMBC Room side removable motor/blower/controls.
- PFM4 MERV 4 washable prefilter. (Std. for non-ducted app.).
- LFI Loaded Filter Indicator Package (factory mounted and wired).
- CPM DOP/PAO Challenge Port and Manifold.
- WMK Wall Mount Speed Control Kit.
- HHRC Hand Held Remote Control.
- STC Scan Testing Certificate
- 10" (254) or 12" (305) or 14" (356) Duct Collar.

Finish:
 SP Special _____

SCHEDULE TYPE:

PROJECT:

ENGINEER:

CONTRACTOR:

Dimensions are in inches (mm).

DATE	B SERIES	SUPERSEDES	DRAWING NO.
9 - 10 - 20	9200	1 - 2 - 20	92FFD



FAN FILTER DIFFUSER

CRITICAL ENVIRONMENT APPLICATIONS

STAINLESS STEEL • ECM • HEPA OR ULPA FILTER

MODEL: 92FFD-SS

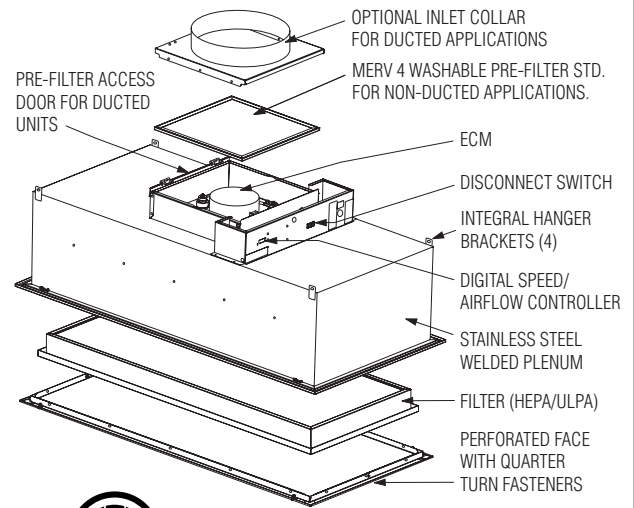
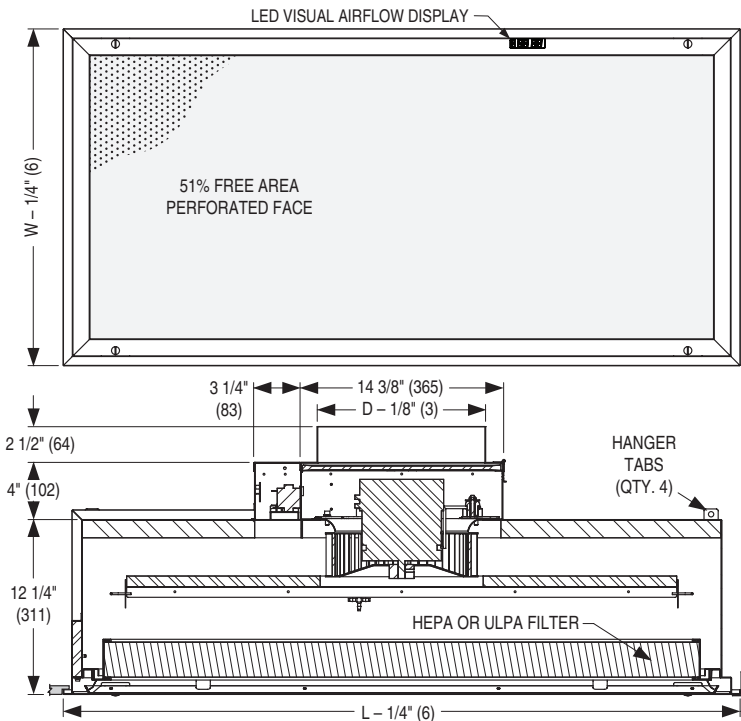

Ceiling Module Sizes

Ceiling Module Size		Inlet Size	
Imperial (inches)	Metric (mm)	Inches	(mm)
24 x 24	600 x 600	Standard (Ductless)	
		14 x 14	356 x 356
36 x 24	900 x 600	Optional (Ducted)	
		10, 12, 14	254, 305, 356
48 x 24	1200 x 600		

DESCRIPTION:

Nailor 92FFD-SS Series Fan Filter Diffusers are designed to supply HEPA/ULPA filtered air to a cleanroom environment. The units are intended for use in cleanroom applications such as microelectronics, pharmaceutical, biotechnology as well as aerospace manufacturing/assembly and laser/optic industries.

All 92FFD-SS series plenums consist of a robotically welded plenum and fan/motor assembly to ensure a repeatable, rigid, clean and near leak free design, meeting the most stringent of current leak tests.

ECM technology provides an ultra-energy efficient design with the ability to precisely set a constant air volume. As filter loading increases fan external static pressure, the ECM will compensate to maintain set airflow.

Filters are secured within the plenum against a continuous knife edge that contacts the gel channel of the filter, providing a leak proof seal. Filters are protected by a perforated face, room-side-removable via quarter turn fasteners.

STANDARD FEATURES:

- 304 Stainless Steel frame and perforated face with 3/16" (5) dia. holes on 60° 1/4" (6) staggered centers (51% free area). The face plate is removable for cleaning, filter replacement and is secured by 1/4 turn fasteners.
- 304 Stainless Steel fully welded plenum.
- Internal Urethane Foam insulation to reduce sound levels.
- Heavy duty hanger brackets.
- LED fan operation indicator (on during normal operation).
- #4 Brushed Satin Polished finish.
- Two Stainless Steel safety cables to prevent accidental dropping of removable face.
- High Efficiency ECM for precise constant airflow and field balancing. Available: 120V/1PH/60Hz, 208V/1PH/60Hz, 240V/1PH/60Hz and 277V/1PH/60Hz.
- Digital speed controller with airflow readout.
- Face accessible SPP.
- HEPA filter (99.99% on 0.3 µm).
- PAO scan tested to IEST RP Standards.
- QF Toggle disconnect switch.
- ETL Listed and Tested to UL 507 Standard.
- Face adjustable airflow control.

OPTIONS:

- 316 Stainless Steel construction.
- UL ULPA Filter (99.9995% on 0.12 µm).
- FBO Filter by others.
- CF Constant Flow EC Motor Program is standard (default).
- CT Constant Torque EC Motor Program is optional.
- RMB Room side removable motor/blower.
- RMBC Room side removable motor/blower/controls.
- PFM4 MERV 4 washable prefilter. (Std. for non-ducted app.).
- LFI Loaded Filter Indicator Package (factory mounted and wired).
- CPM DOP/PAO Challenge Port and Manifold.
- WMK Wall Mount Speed Control Kit.
- HHRC Hand Held Remote Control.
- STC Scan Testing Certificate
- 10" (254) or 12" (305) or 14" (356) Duct Collar.
- Finish:
 - AW Appliance White Epoxy-Polyester Powder Coat
 - SP Special _____

TYPE S Surface Mount Detail

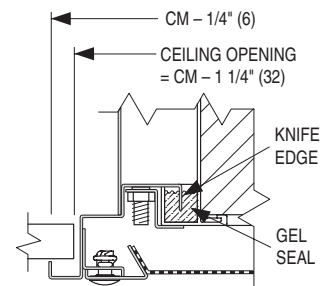

TYPE L Lay-in T-Bar Detail

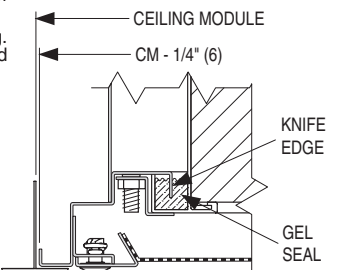

* COMPATIBLE WITH T-BARS UP TO 1 1/2" (38) WIDE

(Standard) 1 1/2" (38) wide.

L20 (Optional) 2" (51) wide.

SPP Standard

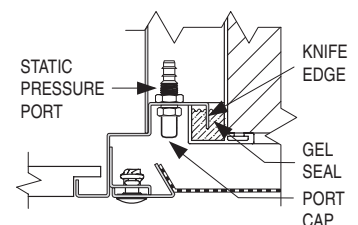

Dimensions are in inches (mm).

SCHEDULE TYPE:

PROJECT:

ENGINEER:

CONTRACTOR:

DATE

B SERIES

SUPERSEDES

DRAWING NO.

9 - 10 - 20

9200

1 - 2 - 20

92FFD-SS

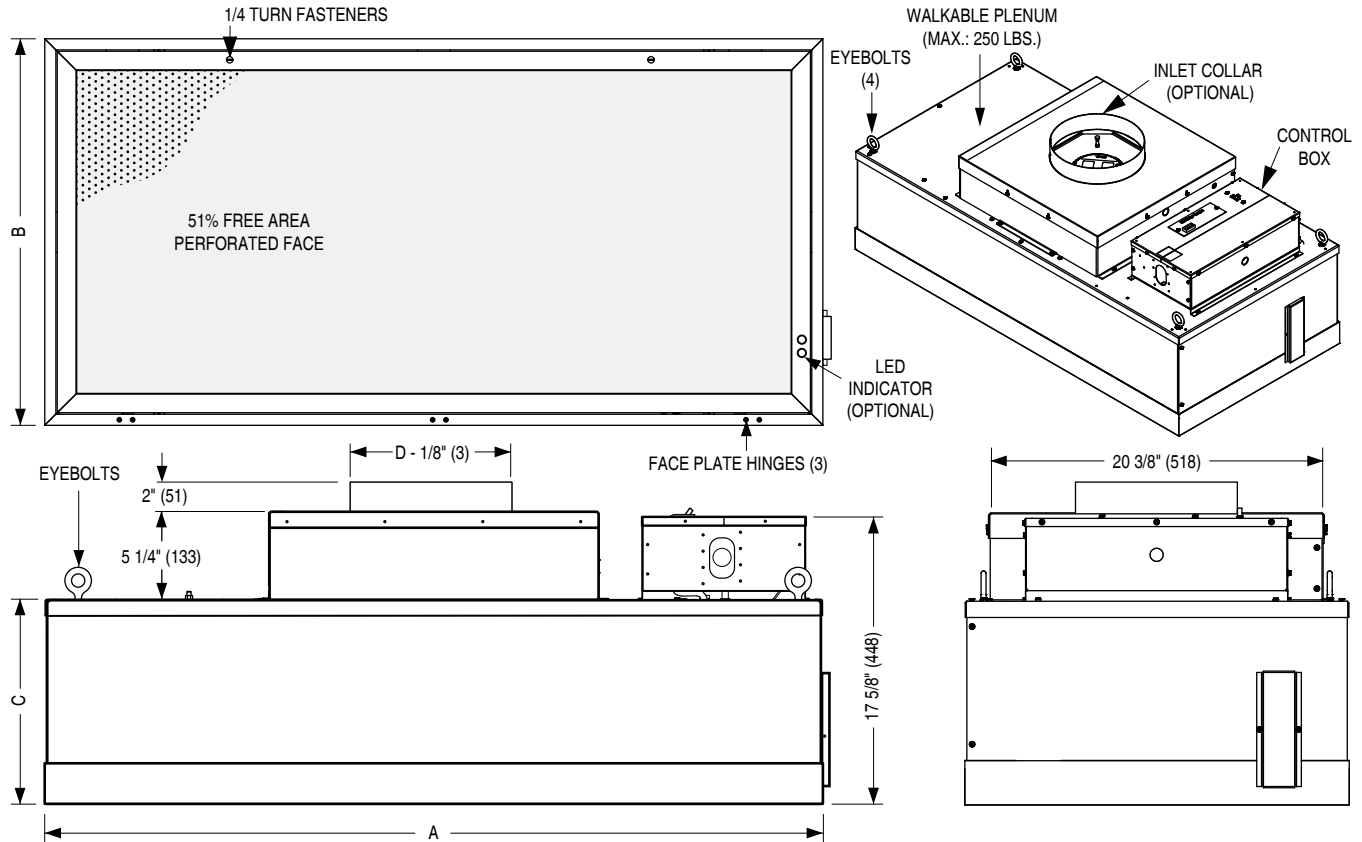

DIMENSIONAL AND ELECTRICAL DATA

Ceiling Module Size Imperial Modules	Unit Measurements			Optional Round Duct Sizes D	ECM FLA (120/208/240/277)V		Weight lbs(kg)
	A	B	C		Backward Curved (BC)	Forward Curved (FC)	
24 x 24	23 11/16 (602)	23 11/16 (602)	12 5/8 (318)	08 (203), 10 (254), 12 (305)	-	3.0/2.0/1.9/1.9	58 (26)
36 x 24	35 11/16 (904)	23 11/16 (602)	12 5/8 (318)	08 (203), 10 (254)	2/1.6/1.5/1.5	4.5/3.0/2.9/2.8	65 (29)
48 x 24	47 11/16 (1211)	23 11/16 (602)	12 5/8 (318)	12 (305), 14 (356)	1.8/1.2/1.1/1.1	4.2/2.8/2.7/2.6	80 (36)

TYPE L Lay-in T-Bar Detail

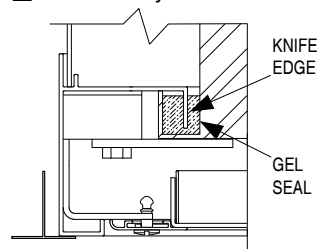

SMFG Surface mount frame w/ gasket (optional accessory)

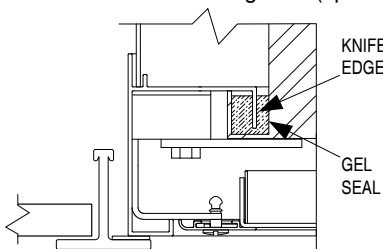

SPP Standard

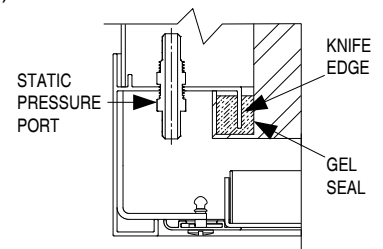

DESCRIPTION:

Nailor 92FFU Fan Filter Units have been designed to supply HEPA/ULPA filtered air to a cleanroom environment in a very efficient manner. The incredibly quiet units offer one of the highest CFM outputs on the market. The units are intended for use in cleanroom applications such as microelectronics, pharmaceutical, biotechnology as well as aerospace manufacturing/assembly and laser/optic industries. All 92FFU series consist of an aluminum welded plenum and fan/motor assembly to ensure a repeatable, rigid, clean and near leak free design, meeting the most stringent of current leak tests. ECM technology provides an ultra-energy efficient design. Filters are secured within the plenum against a continuous knife edge that contacts the gel channel of the filter, providing a leak proof seal. Filters are protected by a perforated hinged face held close by quarter turn fasteners.

SCHEDULE TYPE:	Page 1 of 2			
PROJECT:	Dimensions are in inches (mm).			
ENGINEER:	DATE	B SERIES	SUPERSEDES	DRAWING NO.
CONTRACTOR:	12 - 2 - 25	9200	3 - 13 - 24	92FFU-1



FAN FILTER UNIT • CRITICAL ENVIRONMENT
APPLICATIONS • ALUMINUM FRAME AND PLENUM
ECM • HEPA / ULPA FILTER
MODEL: 92FFU



STANDARD FEATURES:

1. Aluminum frame and perforated face with 3/16" (5) dia. holes on 60° 1/4" (6) staggered centers (51% free area). The face plate is hinged for cleaning, filter replacement, and is secured by two 1/4 turn fasteners.
2. Internal fiber free insulation to reduce sound levels.
3. Eyebolts for ceiling suspension.
4. Plenum and face in Appliance White paint finish.
5. High efficiency EC motor (ECM), single phase, 1/3HP, 60Hz at 24V.
6. Face accessible 3/8" (10) diameter SPP/PAO sample port.
7. Roomside removable HEPA filter (2" media) (99.99% on 0.3 µm).
8. QF Toggle disconnect switch.
9. ETL Listed & Tested to UL 507 Standard.
10. Lay-in T-Bar mounting (Up to 1 1/2" (38) wide)
11. MERV 8 pre-filter. (Standard for non-ducted applications.)
12. Standalone Universal Control Card (UCC)
 - Manual Mode: Onboard trim potentiometer adjustment
 - Analog Mode: 0 – 10 VDC Input
 - Network Mode: Modbus RTU
13. Open plenum square inlet.
14. Topside removable motor/blower.
15. Walkable plenum up to 250 lbs.

OPTIONS:

Ceiling Module Size (inches):

- 24 x 24
- 36 x 24
- 48 x 24

Inlet Size (inches):

- 08 8" dia. round collar
- 10 10" dia. round collar
- 12 12" dia. round collar
- 14 14" dia. round collar

Fan Wheel Type:

- FC Forward Curved (std. eff.)
- BC Backward Curved (high eff.)

Fan Motor Voltage:

- V18 120V ECM
- V19 208V ECM
- V20 240V ECM
- V21 277V ECM

EC Motor Program:

- CF Constant Flow (default for FC blower)
- CT Constant Torque (default for BC blower)

Control:

- LAN Local Area Network (Modbus)

Motor/Blower Access:

- RTMB Roomside and topside removable

Filter Efficiency:

- ULP2 ULPA (2" media) (99.9995% on 0.12 µm)
- NFTR No Filter (order separately)

Plenum Finish:

- PBW British White
- PMI Mill

Face Finish:

- FBW British White
- FMI Mill

Pre-Filter:

- NPF No Pre-filter (default for ducted inlet)
- PF8H MERV 8 w/ side access housing (ducted)
- PFW Washable
- PFWH Washable w/side access housing (ducted)

ACCESSORIES

Motor Run Indicator:

- MRI Face mounted LED light (green)

Loaded Filter Indicator:

- LFI Face mounted LED light (red)

Continuous Filter Monitoring:

- CFM1 Transducer (Modbus)
- CFM2 Transducer (0-10 Vdc terminal block)

PAO Challenge:

- AICP Aerosol Injection Challenge Port (1/2" (13) dia.)

Mounting Accessory:

- SMFG Surface mount frame w/gasket (ships separately)
(See separate submittal 92FFU-SMFG)

Control Option:

- WMK Wall Mount Speed Control Kit
(one per unit. Standalone)

SCHEDULE TYPE:		Page 2 of 2			
PROJECT:		Dimensions are in inches (mm).			
ENGINEER:		DATE	B SERIES	SUPERSEDES	DRAWING NO.
CONTRACTOR:		12 - 2 - 25	9200	3 - 13 - 24	92FFU-1

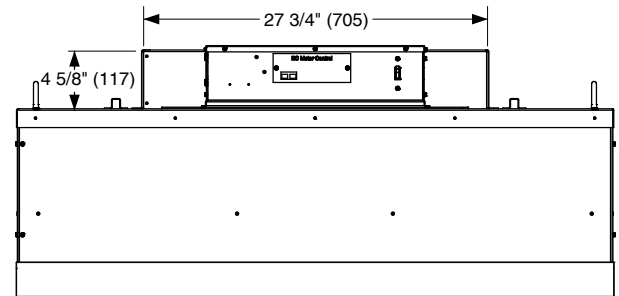
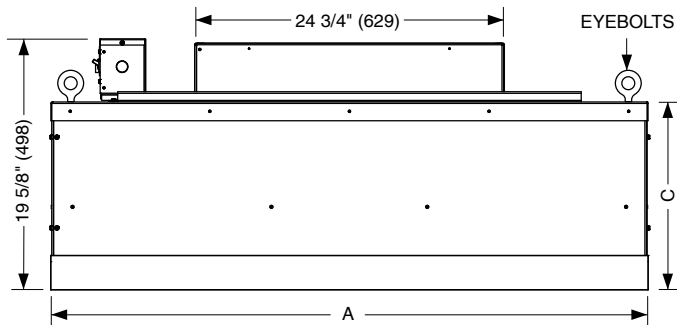
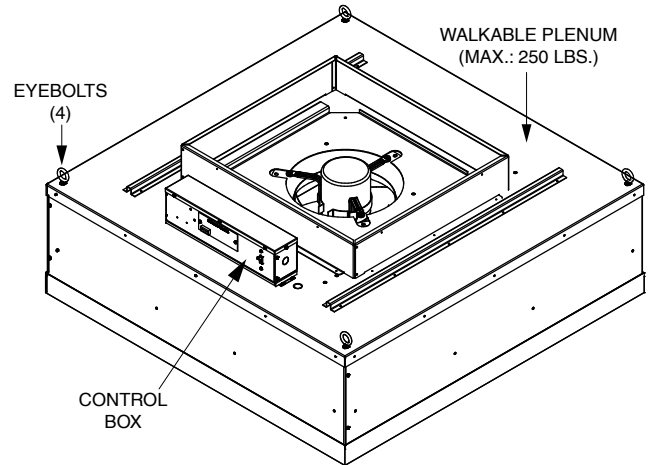
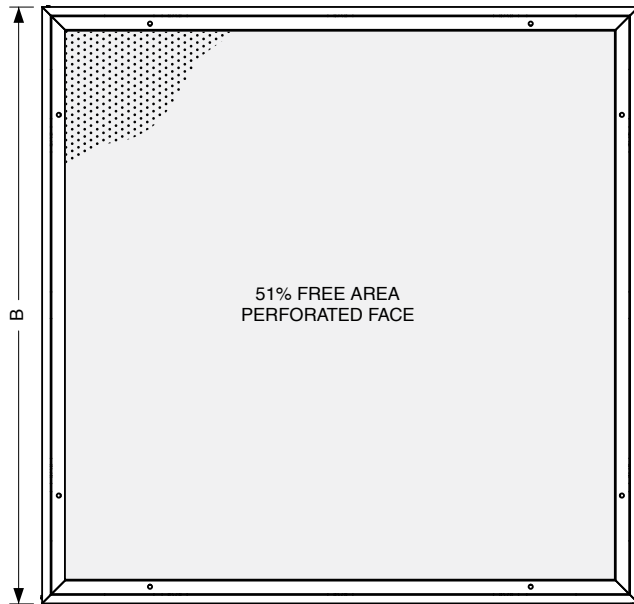

DIMENSIONAL DATA

Ceiling Module Size Imperial Modules	Unit Measurements			Optional Round Duct Sizes D	Weight
	A	B	C		
48 x 48	47 11/16 (1211)	47 11/16 (1211)	14 7/8 (378)	12 (305) 14 (356) 16 (402)	150lbs (68kg)

The 48 x 48 (1219 x 1219) module is only available with the Type L frame. Grid module must be extended by 1/2" for 2" T-bar grids.

DESCRIPTION:

Nailor 92FFU Fan Filter Units have been designed to supply HEPA/ULPA filtered air to a cleanroom environment in a very efficient manner. The larger 48" x 48" sized unit is supplied in a backward curved configuration wheel on a constant torque programmed motor. The larger size makes the unit more cost effective as it will involve less parts for installation, simplify electronic connections to other units and provide the largest amount of surface area for airflow. The units are intended for use in cleanroom applications such as microelectronics, pharmaceutical, biotechnology as well as aerospace manufacturing/assembly and laser/optic industries. All 92FFU series consist of an aluminum welded plenum and fan/motor assembly to ensure a repeatable, rigid, clean and near leak free design, meeting the most stringent of current leak tests. ECM technology provides an ultra-energy efficient design. Filters are secured within the plenum against a continuous knife edge that contacts the gel channel of the filter, providing a leak proof seal. Filters are protected by a perforated hinged face held close by quarter turn fasteners.

SPP Standard

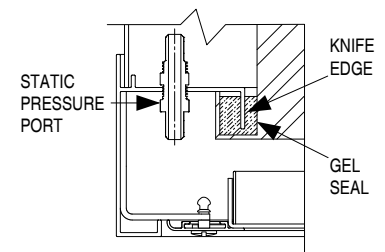

TYPE L Lay-in T-Bar Detail

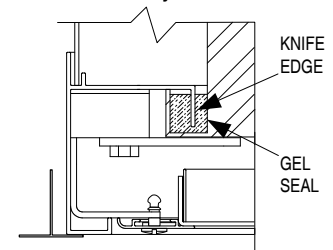

SCHEDULE TYPE:

PROJECT:

ENGINEER:

CONTRACTOR:

Page 1 of 2
Dimensions are in inches (mm).

DATE	B SERIES	SUPERSEDES	DRAWING NO.
12 - 1 - 25	9200	NEW	92FFU-2



FAN FILTER UNIT • CRITICAL ENVIRONMENT
APPLICATIONS • ALUMINUM FRAME AND PLENUM
ECM • HEPA / ULPA FILTER
MODEL: 92FFU 48 x 48 MODULE



STANDARD FEATURES:

1. Aluminum frame and perforated face with 3/16" (5) dia. holes on 60° 1/4" (6) staggered centers (51% free area). The face plate is removable for cleaning, filter replacement, and is secured by 8 bolt fasteners.
2. Standard safety cables prevent accidental dropping of removable face
3. Internal fiber free insulation to reduce sound levels.
4. Eyebolts for ceiling suspension.
5. Plenum and face in Appliance White paint finish.
6. High efficiency EC motor (ECM), single phase, 1/2HP, 60Hz at 24V.
7. Face accessible 3/8" (10) diameter SPP/PAO sample port.
8. QF Toggle disconnect switch.
9. Roomside removable HEPA filter (2" media) (99.99% on 0.3 μm).
10. ETL Listed & Tested to UL 507 Standard.
11. Lay-in T-Bar mounting (Up to 1 1/2" (38) wide) 2" T-Bar must be on 48 1/2" (1232) O.C. modules.
12. MERV 8 pre-filter. (Standard for non-ducted applications.)
13. Standalone Universal Control Card (UCC)
 - Manual Mode: Onboard trim potentiometer adjustment
 - Analog Mode: 0 – 10 VDC Input
 - Network Mode: Modbus RTU
14. Open plenum square inlet.
15. Topside removable motor/blower.
16. Walkable plenum up to 250 lbs.

OPTIONS:

Ceiling Module Size (inches):

- 48 x 48

Inlet Size (inches):

- 12 12" dia. round collar
- 14 14" dia. round collar
- 16 16" dia. round collar

Fan Wheel Type:

- BC Backward Curved (high eff.)

Fan Motor Voltage:

- V18 120V ECM, 6.1 FLA
- V19 208V ECM, 4.2 FLA
- V20 240V ECM, 4.1 FLA
- V21 277V ECM, 4 FLA

EC Motor Program:

- CT Constant Torque (default for BC blower)

Control:

- LAN Local Area Network (Modbus)

Motor/Blower Access:

- RTMB Roomside and topside removable

Filter Efficiency:

- ULP2 ULPA (2" media) (99.9995% on 0.12 μm)
- NFTR No Filter (order separately)

Plenum Finish:

- PBW British White
- PMI Mill

Face Finish:

- FBW British White
- FMI Mill

Pre-Filter:

- NPF No Pre-filter (default for ducted inlet)
- PF8H MERV 8 w/ side access housing (ducted)
- PFW Washable
- PFWH Washable w/side access housing (ducted)

ACCESSORIES

Motor Run Indicator:

- MRI Face mounted LED light (green)

Loaded Filter Indicator:

- LFI Face mounted LED light (red)

Continuous Filter Monitoring:

- CFM1 Transducer (Modbus)
- CFM2 Transducer (0-10 Vdc terminal block)

PAO Challenge:

- AICP Aerosol Injection Challenge Port (1/2" (13) dia.)

Mounting Accessory:

- SMFG Surface mount frame w/gasket (ships separately) (See separate submittal 92FFU-SMFG)

Control Option:

- WMK Wall Mount Speed Control Kit (one per unit. Standalone)

SCHEDULE TYPE:		Page 2 of 2			
PROJECT:		Dimensions are in inches (mm).			
ENGINEER:		DATE	B SERIES	SUPERSEDES	DRAWING NO.
CONTRACTOR:		12 - 1 - 25	9200	NEW	92FFU-2



FAN FILTER UNIT ACCESSORIES
SURFACE MOUNTING FRAME WITH GASKET
ALUMINUM
MODEL: 92FFU-SMFG

ALUMINUM SURFACE MOUNT ADAPTOR FRAME FOR
MODEL SERIES 92FFU FAN FILTER UNIT

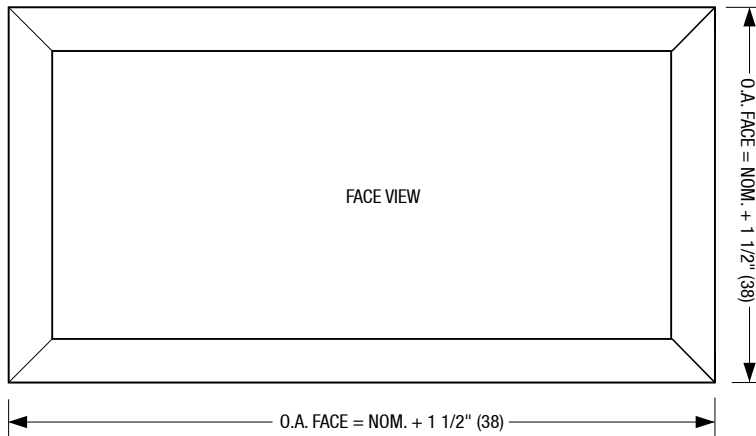
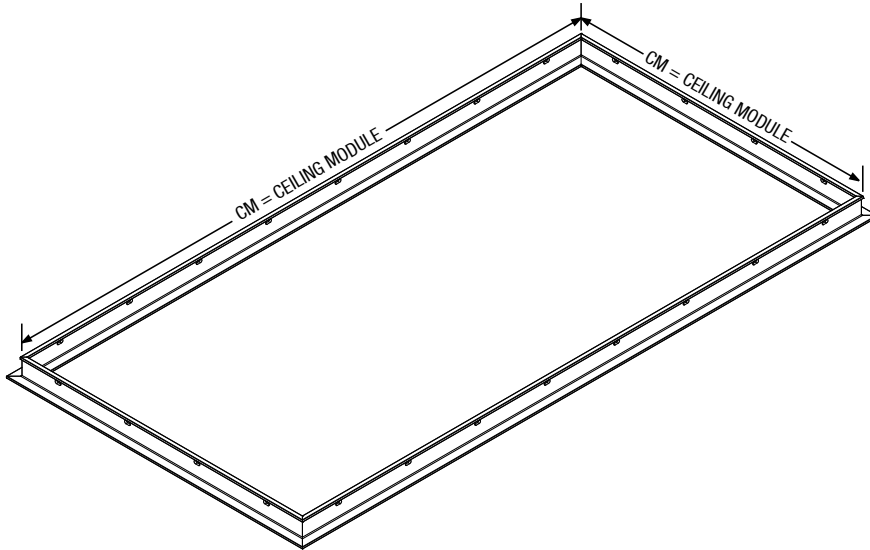

DESCRIPTION:

The Model 92FFU-SMFG for mounting in finished drywall or plaster ceilings to accept the 92FFU fan filter unit.

It allows the retrofit of fan filter units and simplified installation in surface mount applications.

Model 92FFU-SMFG is installed quickly and easily and is suitable for variable ceiling thicknesses. Installation requires hanging the frame up by the punched holes every 6" (152) along the tee to the ceiling using hanger wire (by others). The frame should be hung to a supporting member of the ceiling. The unit can then be mounted onto the frame and supported utilizing the eyebolts installed on the unit.

The finished appearance is professional and aesthetically pleasing.

Material: Heavy duty extruded aluminum extrusion with gasket.

Standard Finish: AW Appliance White.

OPTIONS:

Finish:

SP Special _____

AVAILABLE CEILING MODULES:

IMPERIAL MODULES		METRIC MODULES
Imperial Units (inches)	S.I. Units (mm)	S.I. Units (mm)
24 x 24	610 x 610	600 x 600
36 x 24	914 x 610	900 x 600
48 x 24	1219 x 610	1200 x 600
48 x 48	1219 x 1219	1200 x 1200

Ceiling opening = CM + 3/4" (19)

TYPICAL INSTALLATION

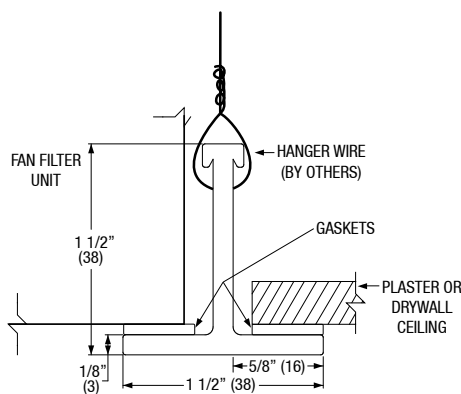

SCHEDULE TYPE:	
PROJECT:	
ENGINEER:	
CONTRACTOR:	

Dimensions are in inches (mm).

DATE	B SERIES	SUPERSEDES	DRAWING NO.
1 - 29 - 26	ACC-9200	NEW	ACC-SMFG

Nailor offers a selection of standard colors and finishes available on our grilles, registers and diffusers. For painted finishes, our state-of-the-art paint systems provide environmentally friendly finishing solutions with uniform coverage and coating thickness. The result is an exceptionally durable finish that resists scratching, corrosion and general wear. Additional facilities for special requirements, as well as a selection of anodized or brushed finishes, complete our ability to provide unmatched beauty and durability for any application.

NAILOR POWDER COAT PROPERTIES

FILM THICKNESS	2.0 to 3.0 mils
HARDNESS	2 H
IMPACT RESISTANCE	Direct: 160 inch - lbs. Reverse 160 inch - lbs.
SALT SPRAY	1000 hours

ELECTROCOATING PROPERTIES

FILM THICKNESS	.8 to 1.2 mils
HARDNESS	HB TO H
IMPACT RESISTANCE	80 inch - lbs
SALT SPRAY	100 hours

POWDER COAT

Nailor's powder coat is a high-tech thermosetting polyester powder coating with superior physical properties that provide excellent color and gloss retention. The finish offers extreme durability and hardness that resists scratching, chipping and general wear. Surface preparation includes degreasing and a chemical cleaning followed by a clean rinse before a final powder coat finish is applied and baked. The environmentally friendly Nailor powder coat system assures uniform coverage and color consistency resulting in a long lasting superior finish. Colors, including simulated anodizing, which is far more economical than color anodizing, can be selected from Nailor's standard color chart or non-standard colors and can be matched from sample chips provided to Nailor.

ELECTROCOATING

E-Coat is an environmentally friendly coating that provides complete coverage and a wide range of performance properties, formulated to meet corrosion, durability and other performance specifications. Electrocoating is a highly automated process in which paint is electrically deposited onto a metal foundation. Film build thickness is uniform and overall application efficiencies are in excess of 90%. Paint is consistent on all part-to-part surfaces, preventing sags, runs or drips. E-Coat offers flexibility, better first yield pass and quicker production times compared to other forms of paint applications. Electrocoating is an excellent solution that offers superior properties and uniform finish.

CLEAR ANODIZING (Aluminum products only)

Clear anodizing is a clear oxide coating that exemplifies an aluminum surface's natural oxide coating producing a hard, scratch resistant surface that is resistant to general wear and mild chemicals. The process provides a natural looking, virtually maintenance free finish that will endure for many years.

COLOR ANODIZING (Aluminum products only)

Color anodizing is an electrolytic process where, after standard anodizing procedures, colored metallic pigments penetrate the oxide surface pores producing a corrosion resistant, colorfast finish. The process results in a natural metallic appearance that requires little maintenance.

BRUSHED AND CLEAR COAT

Available on specific aluminum products (consult applicable product page for availability). Surface is brushed to achieve a scratch finish texture before being degreased and chemically cleaned. A clear lacquer coating is then applied to provide a durable protective finish.

#4 BRUSHED SATIN POLISHED (Stainless Steel products only)

Surface is polished to ASTM A480 #4 standard to achieve a bright durable finish that is resistant to mild chemicals and corrosion. A final coating is not required due to the inherent anti-corrosion properties of the stainless steel.

PRIME COAT

Prime coat provides a stable base for painting in the field. Surface pretreatment includes degreasing and a chemical cleaning before an alkyd prime coat is applied. After a thorough cleaning for dust, etc. that can contaminate the final finish and cause premature flaking or peeling, finish coat should be field applied as soon as possible.

PAINT PREPARED ALUMINUM (Aluminum products only)

Allows for field applied paint. Surface preparation includes degreasing and a chemical cleaning followed by a clean rinse. Finish coat should be field applied as soon as possible.

MILL FINISH

Surface is left untreated and requires cleaning, degreasing, etc. in the field before final finish can be applied if required.



Nailor[®]
Industries Inc.

STANDARD AND OPTIONAL FINISHES FOR GRILLES AND DIFFUSERS

The following standard colors and finishes are available on applicable Nailor air distribution products. Consult individual product pages for availability

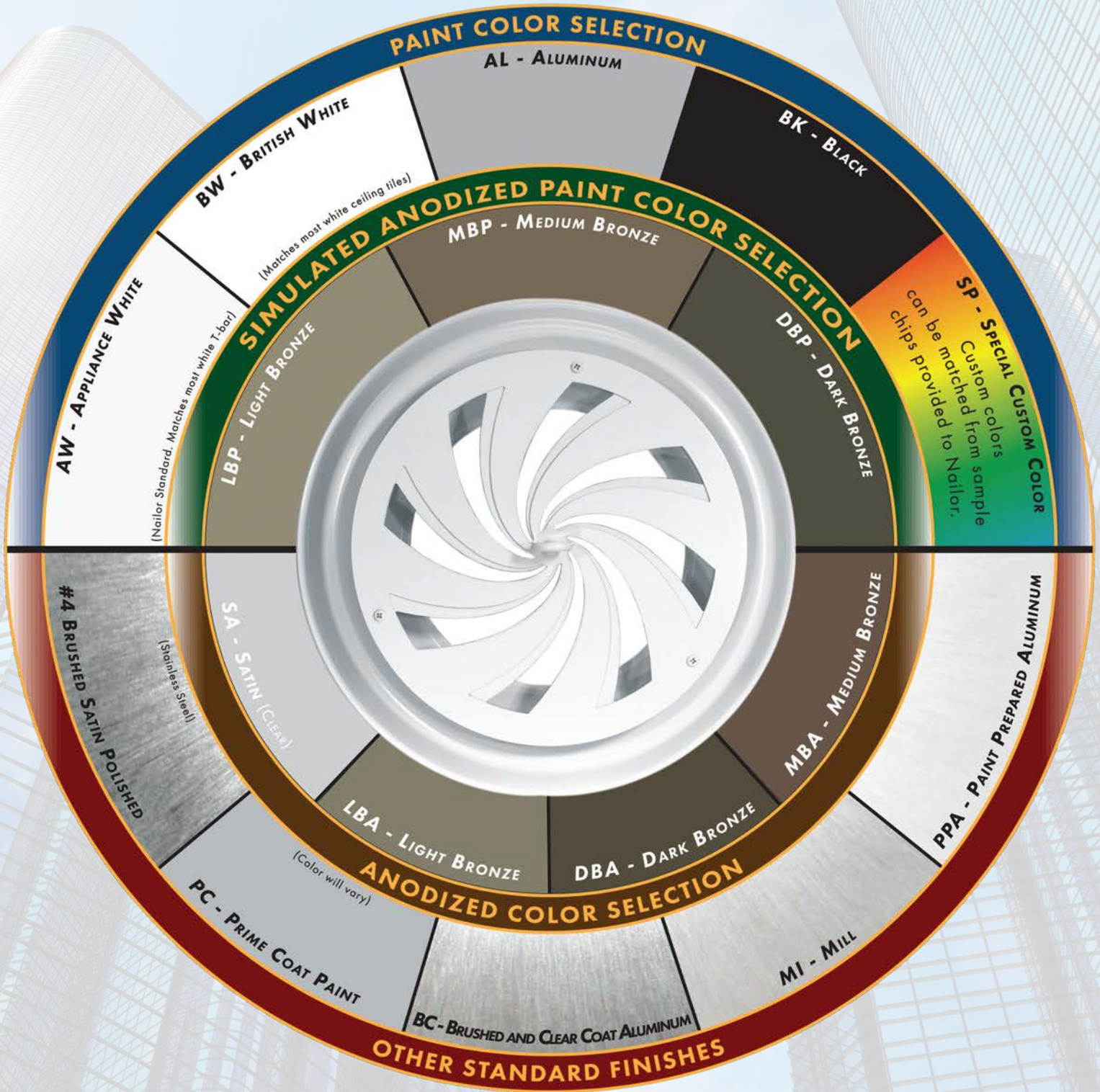

The pictured finishes have been represented as best as possible within printing limitations. However, actual finish may vary. Contact your Nailor representative for a color chip sample on the material specified for a more accurate representation.

DBK - Black (for registers ordered with factory mounted dampers) - **BA** - Perforated Diffusers (4300 series only) Appliance White (AW) face with black back pan and pattern controllers.

"Complete Air Control and Distribution Solutions."

WGDSOF2015

www.nailor.com

PERFORMANCE DATA:

92FFD SERIES • FAN PERFORMANCE CURVES

ECM • With HEPA Filter • 99.99% Minimum Removal Efficiency on 0.30 Micrometer Particle Size

Unit Size 24" x 24" (610 x 610)

120V, 208V, 240V and 277V

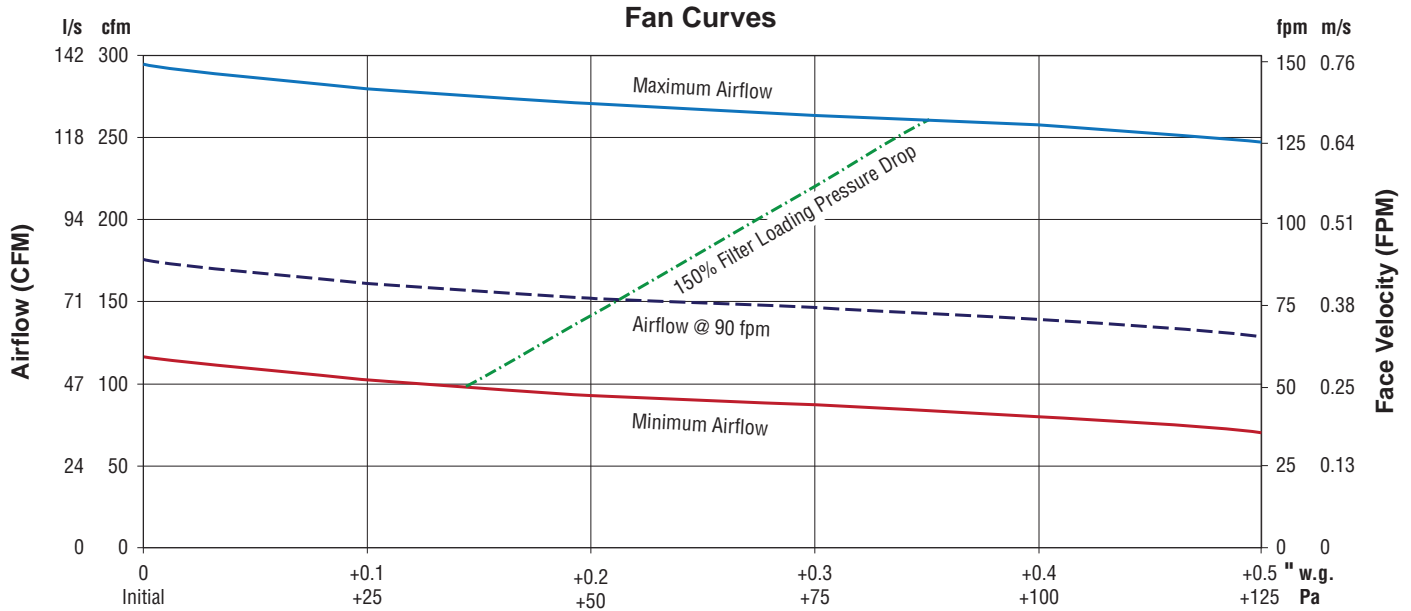

**Airflow @ Initial Filter Resistance
Loaded Filter Static (" w.g.) Coefficient***

1. A coefficient for factory supplied filter loading can be obtained from the provided line. IEST recommends the filter be replaced @ 150% of initial pressure drop.
2. For example: If initial filter resistance = .5" w.g., use the provided line to estimate the additional static pressure, @ indicated airflow, for a 150% loaded filter. Add the additional static pressure to the initial pressure drop, @ indicated airflow, to determine maximum allowable pressure drop.

Unit Size 36" x 24" (914 x 610)

120V, 208V, 240V and 277V

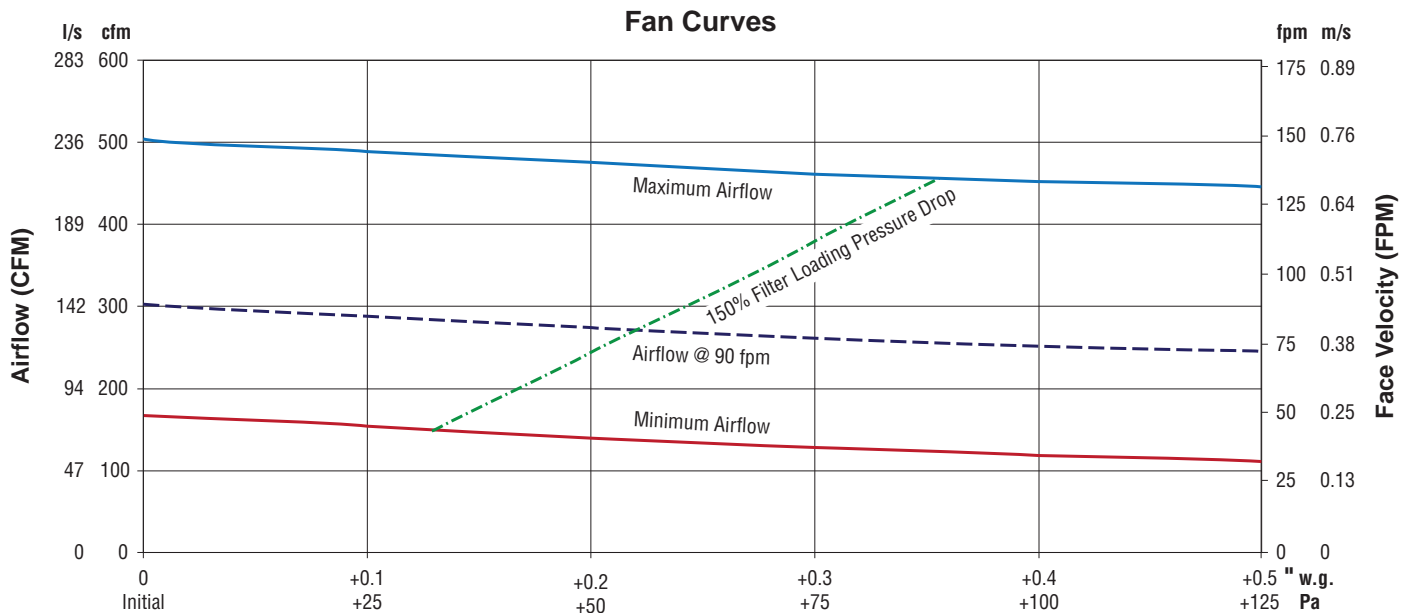

**Airflow @ Initial Filter Resistance
Loaded Filter Static (" w.g.) Coefficient***

1. A coefficient for factory supplied filter loading can be obtained from the provided line. IEST recommends the filter be replaced @ 150% of initial pressure drop.
2. For example: If initial filter resistance = .5" w.g., use the provided line to estimate the additional static pressure, @ indicated airflow, for a 150% loaded filter. Add the additional static pressure to the initial pressure drop, @ indicated airflow, to determine maximum allowable pressure drop.

PERFORMANCE DATA:

92FFD SERIES • FAN PERFORMANCE CURVES

ECM • With HEPA Filter • 99.99% Minimum Removal Efficiency on 0.30 Micrometer Particle Size

Unit Size 48" x 24" (1219 x 610)

120V, 208V, 240V and 277V

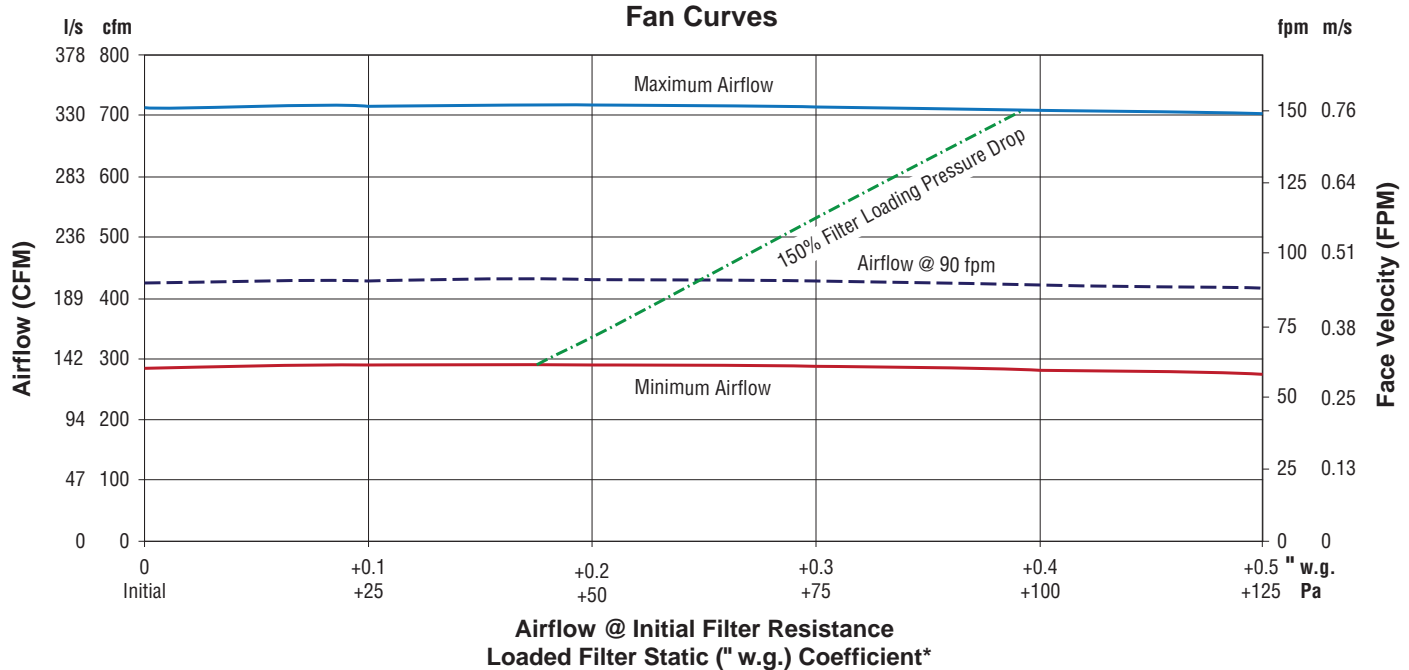

1. A coefficient for factory supplied filter loading can be obtained from the provided line. IEST recommends the filter be replaced @ 150% of initial pressure drop.
2. For example: If initial filter resistance = .5" w.g., use the provided line to estimate the additional static pressure, @ indicated airflow, for a 150% loaded filter. Add the additional static pressure to the initial pressure drop, @ indicated airflow, to determine maximum allowable pressure drop.

PERFORMANCE DATA:

92FFD SERIES

ECM • With HEPA Filter • 99.99% Minimum Removal Efficiency on 0.30 Micrometer Particle Size

Nominal Unit Size	Voltage [V/PH/Hz]	Active Filter Area [sq. ft.]	Operating Range [fpm]	Max. Airflow [cfm]	Min. Airflow [cfm]	Airflow @ 90 fpm [cfm]	Amps @ 90 fpm	Watts @ 90 fpm	Initial Resistance @ 90 fpm [in. - w.g.]	Weight [lbs.]	Motor Heat Gain [BTU]	Sound @ 90 fpm [dBA]
24 x 24	120/1/60	1.96	50 - 160	310	100	176	1.20	75	0.45	60	257	50
24 x 24	208/1/60	1.96	55 - 170	330	105	176	0.65	71	0.45	60	242	50
24 x 24	240/1/60	1.96	55 - 170	330	105	176	0.65	71	0.45	60	242	50
24 x 24	277/1/60	1.96	60 - 170	330	115	176	0.65	74	0.45	60	253	50
36 x 24	120/1/60	3.37	45 - 170	575	160	303	1.20	73	0.45	70	248	47
36 x 24	208/1/60	3.37	45 - 165	555	155	303	0.70	76	0.45	70	259	47
36 x 24	240/1/60	3.37	45 - 165	555	155	303	0.70	76	0.45	70	259	47
36 x 24	277/1/60	3.37	50 - 160	535	165	303	0.60	77	0.45	70	261	47
48 x 24	120/1/60	4.77	25 - 145	685	120	429	2.00	131	0.45	90	446	51
48 x 24	208/1/60	4.77	25 - 145	705	125	429	1.05	117	0.45	90	401	51
48 x 24	240/1/60	4.77	25 - 145	705	125	429	1.05	117	0.45	90	401	51
48 x 24	277/1/60	4.77	60 - 145	700	280	429	1.05	124	0.45	90	422	51

NOTES:

1. All airflow tested in accordance with current version of IEST-RP-CC002.3 UNI DIRECTIONAL – FLOW, clean air devices.
2. Initial resistance refers to the static pressure associated with a clean filter at the corresponding face velocity.
3. Active filter area is based on factory supplied filter. Use of field supplied filters will result in different active filter areas.
4. Per IEST-RP-CC002.3, filters should be replaced once the internal static pressure has reached 1.5 times initial resistance at corresponding face velocity.