

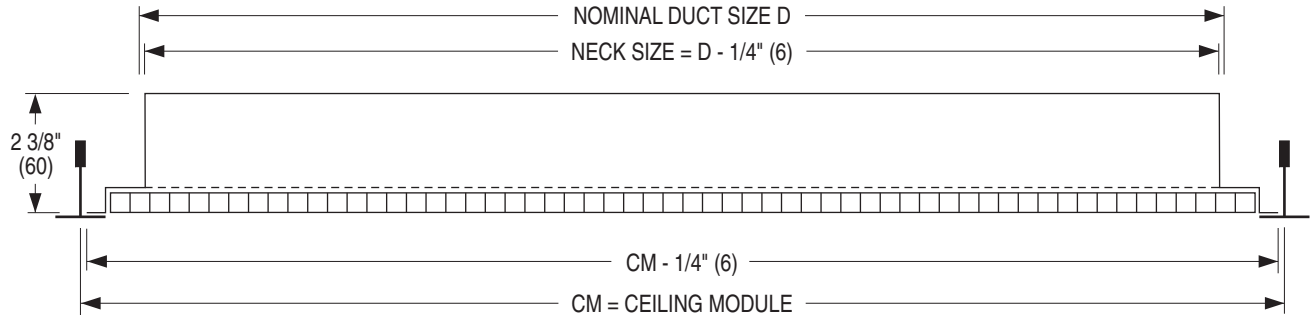

**EGGCRATE RETURN CEILING DIFFUSERS**  
**SQUARE NECK (FULL SIZE)**  
**MODELS: 4260, 4260AA**

**TYPE L Lay-in T-Bar**



**Imperial Module & Metric Module Table**

Ceiling Module CM		Nominal Duct Size D	
Imperial Modules	Metric Modules	Square Neck	
		Imperial Modules (inches)	Metric Modules (mm)
12 x 12	300 x 300	10 x 10	250 x 250
24 x 12	600 x 300	22 x 10	550 x 250
20 x 20	500 x 500	18 x 18	450 x 450
24 x 24	600 x 600	22 x 22	550 x 550
48 x 24	1200 x 600	46 x 22	1150 x 550

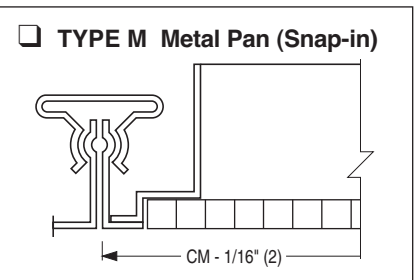
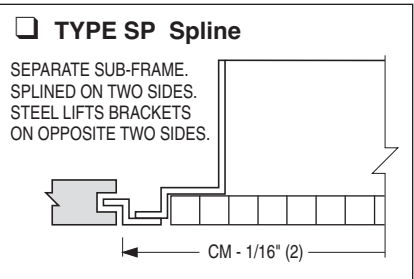
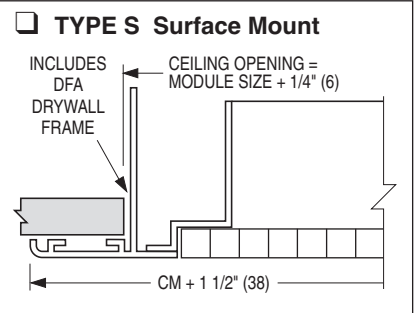

**DESCRIPTION:**

1. Material: Corrosion-resistant steel frame with 1/2" x 1/2" x 1/2" (13 x 13 x 13) aluminum grid core (Model 4260 is standard).
2. Full face eggcrate architecturally pleasing design provides a high free area for high volume capacity with low sound levels and pressure drop. This version is for ducted or ductless return applications. Features a dedicated frame assembly which has a neck that is 2" (51) less than the ceiling module size for maximum free area.
3. Removable core. Secured with four semi-concealed screws.
4. Optional damper for balancing is supplied with steel barbed S-clips for easy field mounting directly on the neck. Adjustment is with a flat blade screwdriver through the face.
5. Standard finish is AW Appliance White.

**OPTIONS:**

- Aluminum core with aluminum frame. (Model 4260AA).  
Finish:
- BA Black back pan with Appliance White face.
- SP Special \_\_\_\_\_.

**ACCESSORIES** (ordered separately):

- OBD Type SL. Steel opposed blade damper.
- OBD-A Type SL. Aluminum opposed blade damper.

<b>SCHEDULE TYPE:</b>
<b>PROJECT:</b>
<b>ENGINEER:</b>
<b>CONTRACTOR:</b>

Dimensions are in inches (mm).

<b>DATE</b>	<b>B SERIES</b>	<b>SUPERSEDES</b>	<b>DRAWING NO.</b>
2 - 6 - 17	4200	3 - 10 - 16	4260-1



# EGGCRATE RETURN CEILING DIFFUSERS

## ROUND OR SQUARE NECK

### MODELS: 4260, 4260AA

**TYPE L Lay-in T-Bar**

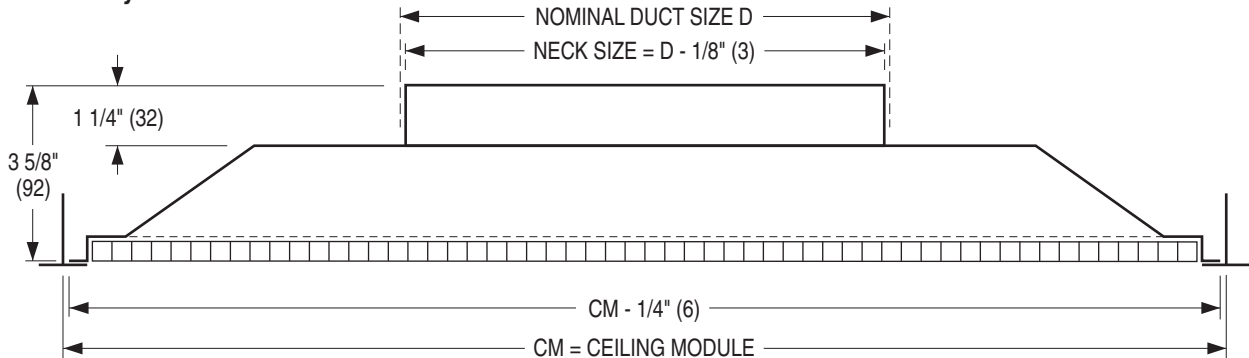

**Available Combinations of Ceiling Module vs. Neck Size**

Ceiling Module CM		Nominal Duct Size D			
Imperial Modules	Metric Modules	Round Neck		Square Neck	
		Imperial Units (in.)	Metric Units (mm)	Imperial Units (in.)	Metric Units (mm)
12 x 12	300 x 300	6, 8	152, 203	6 x 6, 8 x 8	152 x 152, 203 x 203
24 x 12	600 x 300	6, 8	152, 203	6 x 6, 8 x 8, 18 x 6,	152 x 152, 203 x 203, 457 x 152
20 x 20	500 x 500	6, 8, 10, 12, 14	152, 203, 254, 305, 356	6 x 6, 8 x 8, 10 x 10, 12 x 12, 14 x 14	152 x 152, 203 x 203, 254 x 254, 305 x 305, 356 x 356
24 x 24	600 x 600	6, 8, 10, 12, 14, 15, 16, 18	152, 203, 254, 305, 356, 381, 406, 457	6 x 6, 8 x 8, 10 x 10, 12 x 12, 14 x 14, 15 x 15, 16 x 16, 18 x 18	152 x 152, 203 x 203, 254 x 254, 305 x 305, 356 x 356, 381 x 381, 406 x 406, 457 x 457

**TYPE S Surface Mount**

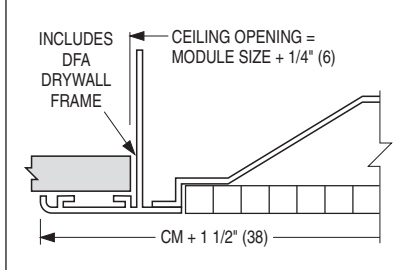

**TYPE SP Spline**

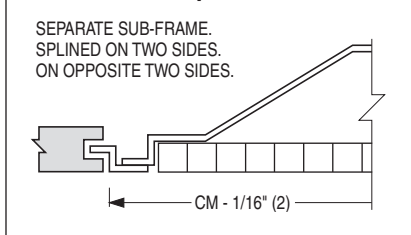

**TYPE M Metal Pan (Snap-in)**

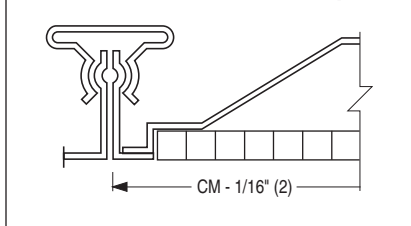

**DESCRIPTION:**

1. Material: Corrosion-resistant steel backpan with 1/2" x 1/2" x 1/2" (13 x 13 x 13) aluminum grid core. (Model 4260 is standard).
2. Full face eggcrate architecturally pleasing design provides a high free area for high volume capacity with low sound levels and pressure drop. This version is for ducted return applications; for connection to flexible or rigid round duct or square duct.
3. Removable core. Secured with four semi-concealed screws.
4. Optional damper for balancing is supplied with steel barbed S-clips for easy field mounting directly on the neck. Adjustment is with a flat blade screwdriver through the face.
5. Standard finish is AW Appliance White.

**OPTIONS:**

- Aluminum core with aluminum frame. (Model 4260AA).
- Finish:
  - BA Black back pan with Appliance White face.
  - SP Special \_\_\_\_\_.

**ACCESSORIES (ordered separately):**

**Round Neck:**

- 4250 Radial sliding damper.
- 4275 Radial opposed blade damper.

**Square Neck:**

- OBD Type SL. Steel opposed blade damper.
- OBD-A Type SL. Aluminum opposed blade damper.

<b>SCHEDULE TYPE:</b>		Dimensions are in inches (mm).			
<b>PROJECT:</b>					
<b>ENGINEER:</b>	<b>DATE</b>	<b>B SERIES</b>	<b>SUPERSEDES</b>	<b>DRAWING NO.</b>	
<b>CONTRACTOR:</b>	2 - 6 - 17	4200	3 - 22 - 16	4260-2	

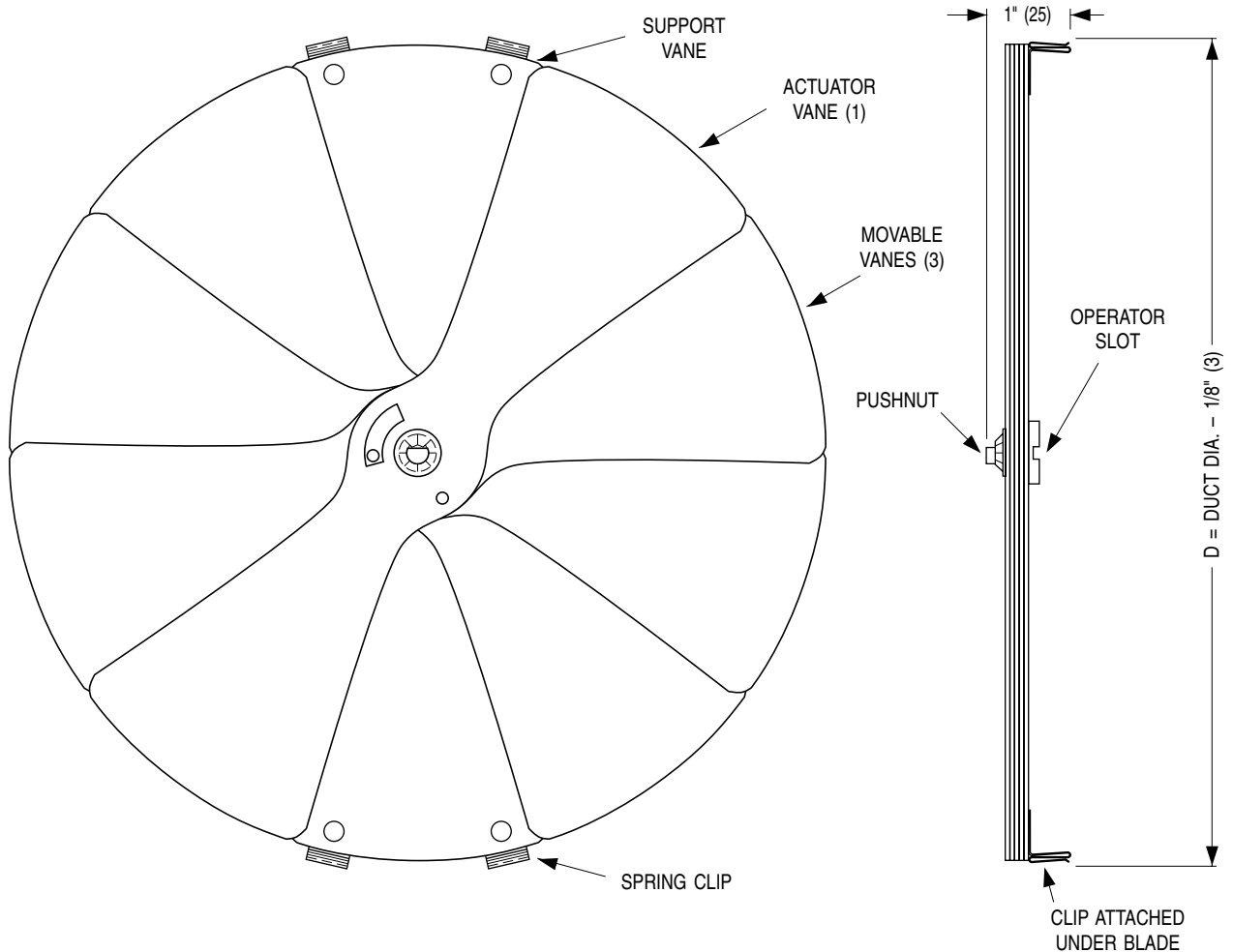
**DESCRIPTION:**

1. Material: Heavy gauge corrosion-resistant steel.
2. The Nailor Model 4250 is a neck mounted, radial sliding blade damper used in round neck diffuser applications to provide fine volume control.
3. Dampers have gang operated radial blades. Blades slide at right angles to the duct with protrusion above the diffuser neck, allowing the damper to work effectively in flexible duct applications.
4. The 4250 is neck mounted with steel barb clips providing secure attachment.
5. Adjustments are made at the screwdriver operator slot.
6. Available Sizes: 6", 8", 10", 12" and 14" (152, 203, 254, 305 and 356) dia..

**SCHEDULE TYPE:**
**PROJECT:**
**ENGINEER:**
**CONTRACTOR:**

Dimensions are in inches (mm).

**DATE**
**B SERIES**
**SUPERSEDES**
**DRAWING NO.**

10 - 24 - 01

ACC.DIF.

25 - 8 - 99R

ABD-4250



# AIR BALANCING DEVICE RADIAL OPPOSED BLADE DAMPER STEEL • FOR ROUND NECK DIFFUSERS MODEL: 4275 (5" - 16" DIA.)

## DESCRIPTION:

A unique method of controlling volume through a diffuser providing premium design quality and performance. The multi-blade perimeter design offers true radial flow at any setting.

A screwdriver slot, accessible through the diffuser, requires only a half turn to adjust from fully closed to fully open. The damper is designed to fit directly on the neck of the diffuser. Simple convenient and accurate installation and operation.

## OPERATION:

Size 5 through 8 are friction type. Use screwdriver and turn operator to adjust damper setting.

Size 10 through 16 use a detent mechanism to positively hold damper setting. Using screwdriver, lift up and turn operator to desired damper setting.

1. Material: Corrosion-resistant steel construction.
2. Damper mounts directly to diffuser collar.
3. Standard Finish: Mill.

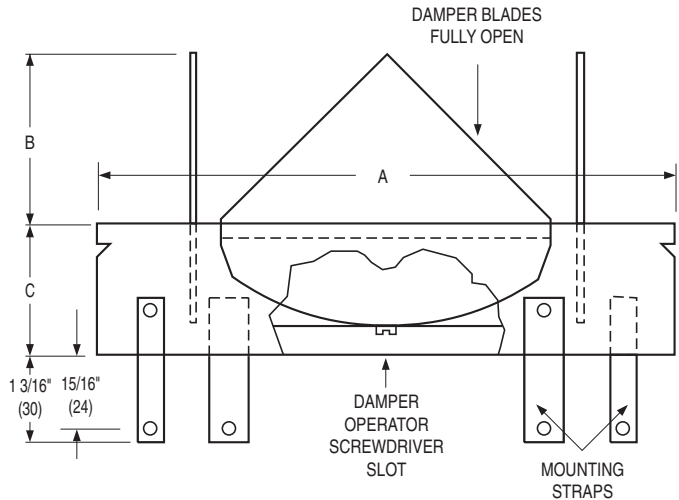
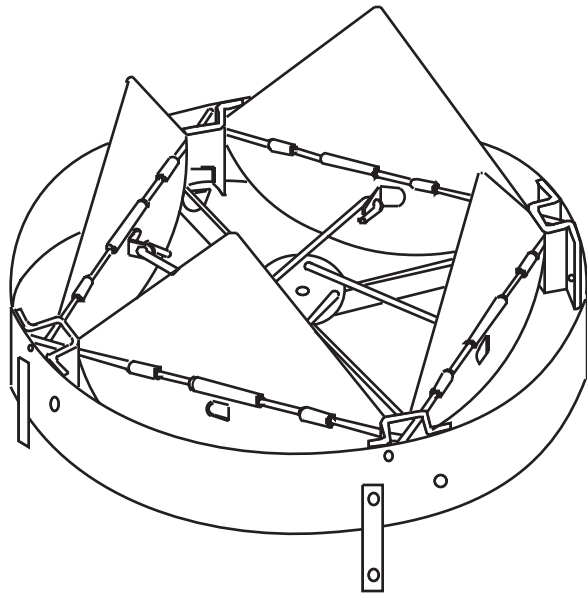

	Nominal Size (inches)								Nominal Size (mm)							
	5	6	8	10	12	14	15	16	127	152	203	254	305	356	381	406
A	4 7/8	5 7/8	7 7/8	9 7/8	11 7/8	13 7/8	14 7/8	15 7/8	124	149	200	251	302	352	378	403
B	1 1/8	1 5/8	2 1/2	2 1/4	2 7/8	3 3/8	3 3/4	4 3/8	29	41	64	57	73	86	95	111
C	1 5/8				2 1/2				41				64			

SCHEDULE TYPE:

PROJECT:

ENGINEER:

CONTRACTOR:

Dimensions are in inches (mm).

DATE

B SERIES

SUPERSEDES

DRAWING NO.

8 - 29 - 05

ABD

3 - 1 - 02

ABD-4275-1



**AIR BALANCING DEVICE**  
**RADIAL OPPOSED BLADE DAMPER**  
 STEEL • FOR ROUND NECK DIFFUSERS  
**MODEL: 4275 (18" DIA.)**

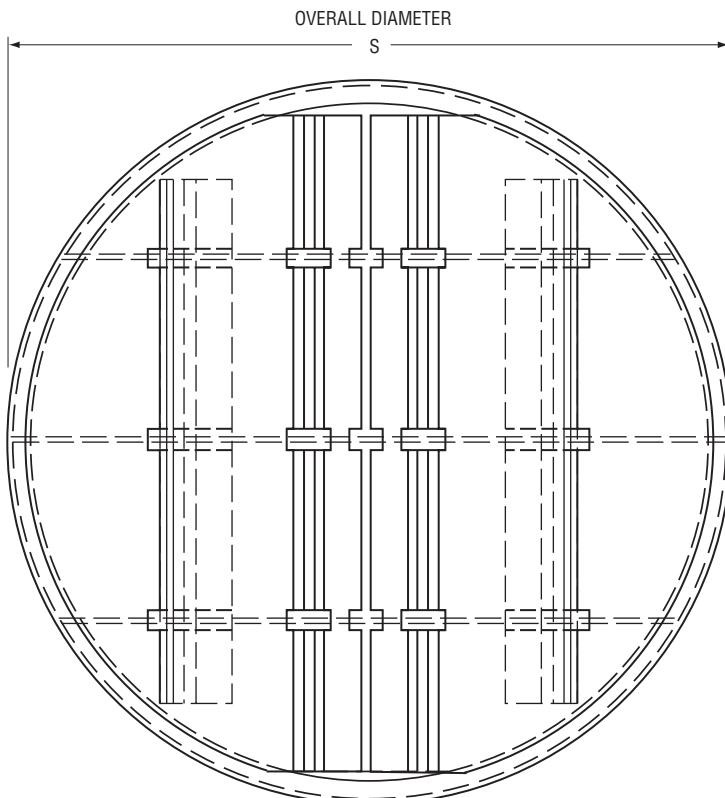

**TOP VIEW**  
**VALVES CLOSED**

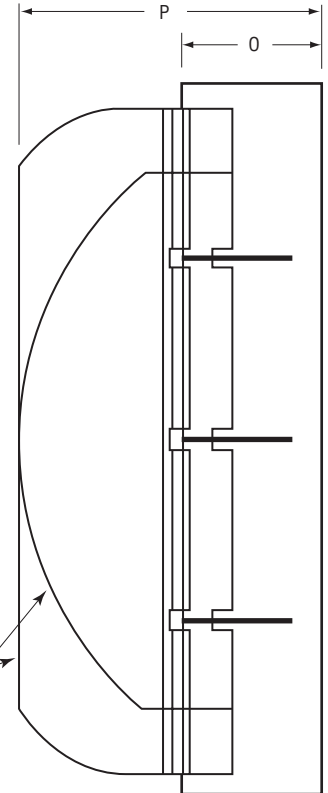

OPPOSED BLADE  
 DAMPER VALVES  
 FULLY OPEN

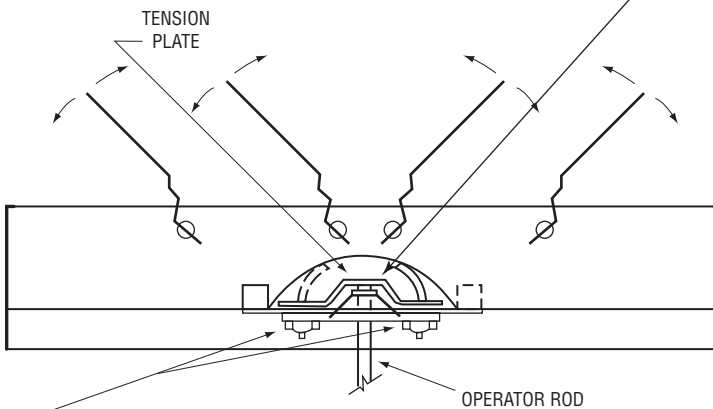

**CROSS SECTION WITH VALVES PARTLY OPEN**  
**SHOWING OPPOSED BLADE OPERATION.**

IF OPERATOR IS TO BE REMOVED AFTER SETTING DAMPER, DO NOT DRIVE INTO TENSION PLATE AS THIS LOCKS ROD IN PLACE FOR PERMANENT INSTALLATION.

LOCK NUTS:  
 LOOSEN BEFORE ADJUSTING DAMPER.  
 TIGHTEN AFTER ADJUSTING DAMPER TO PROVIDE POSITIVE LOCK.

**DESCRIPTION:**

1. Material: Steel construction.
2. Screw or rivet to duct.
3. Opposed blade operation.
4. Finish: Black.

List Dia.	Imperial Modules			Metric Modules		
	Imperial Units (inches)			SI Units (mm)		
	S	O	P	S	O	P
18"	17 7/8	1 3/4	4 3/4	454	44	121

**SCHEDULE TYPE:**

**PROJECT:**

**ENGINEER:**

**CONTRACTOR:**

Dimensions are in inches (mm).

DATE	B SERIES	SUPERSEDES	DRAWING NO.
11 - 26 - 07	4200	8 - 30 - 05	ABD-4275-3



**AIR BALANCING DEVICE  
BUTTERFLY DAMPER  
STEEL • FOR ROUND NECK DIFFUSERS  
MODEL: 4675**

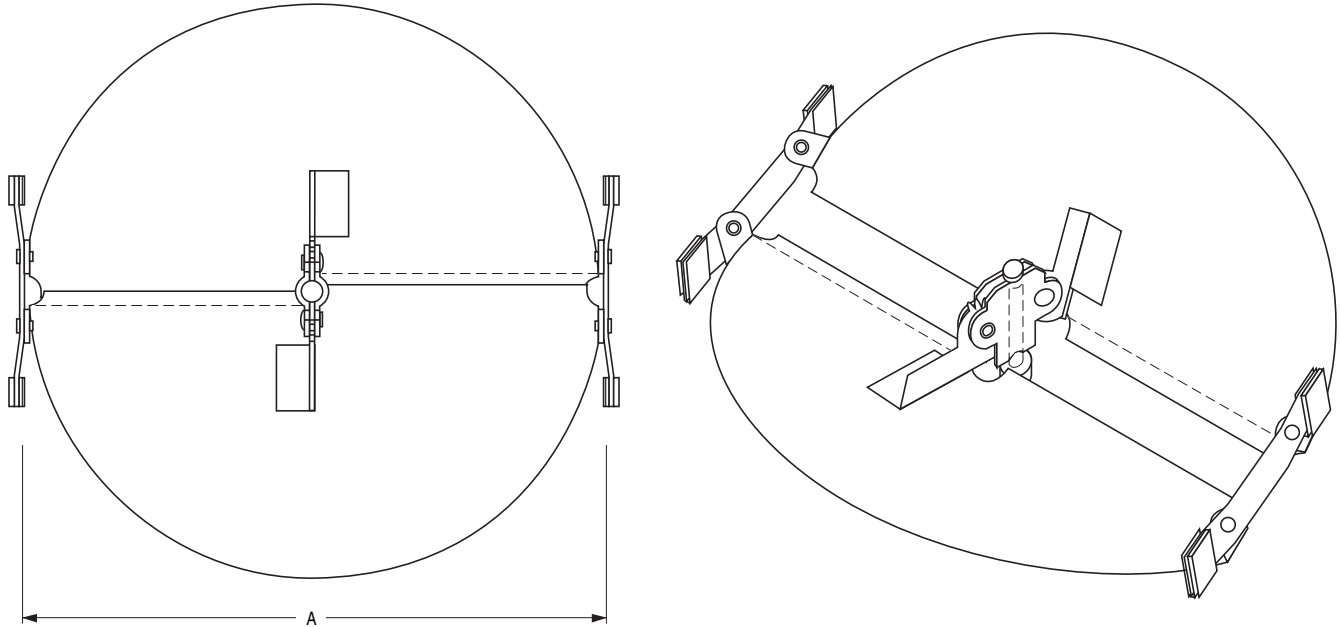

**DESCRIPTION:**

The Model 4675 Butterfly Damper is an economical damper for volume balancing in round neck diffusers. Adjustable friction pivots hold the blades at the required setting.

1. Material: Corrosion-resistant steel. Mill finish.
2. The 4675 damper mounts directly to diffuser collar. Not compatible with Model Series RNSA, RNR, RNRA1, 6300 or 6300R diffusers.
3. Screwdriver slot operator is adjustable from the face of the diffuser.

	Nominal Size (inches)					Nominal Size (mm)				
	6	8	10	12	14	152	203	254	305	356
A	5 7/8	7 7/8	9 7/8	11 7/8	13 7/8	149	200	251	302	352
B	2 1/2	3 1/2	4 1/2	5 1/2	6 1/2	64	89	114	140	165

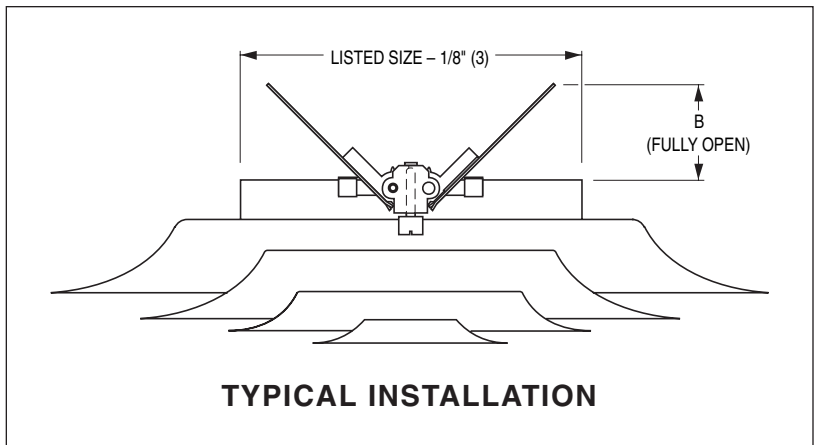

<b>SCHEDULE TYPE:</b>					Dimensions are in inches (mm).				
<b>PROJECT:</b>									
<b>ENGINEER:</b>					<b>DATE</b>	<b>B SERIES</b>	<b>SUPERSEDES</b>	<b>DRAWING NO.</b>	
<b>CONTRACTOR:</b>					11 - 14 - 08	ACC.DIF.	5 - 28 - 08	ABD-4675	



**AIR BALANCING DEVICES  
OPPOSED BLADE DAMPER • NECK MOUNTED  
FOR SQUARE AND RECTANGULAR NECKS  
MODEL: OBD TYPE SL & PL**

**TYPE SL** Screwdriver Slot Face Operator (Standard)

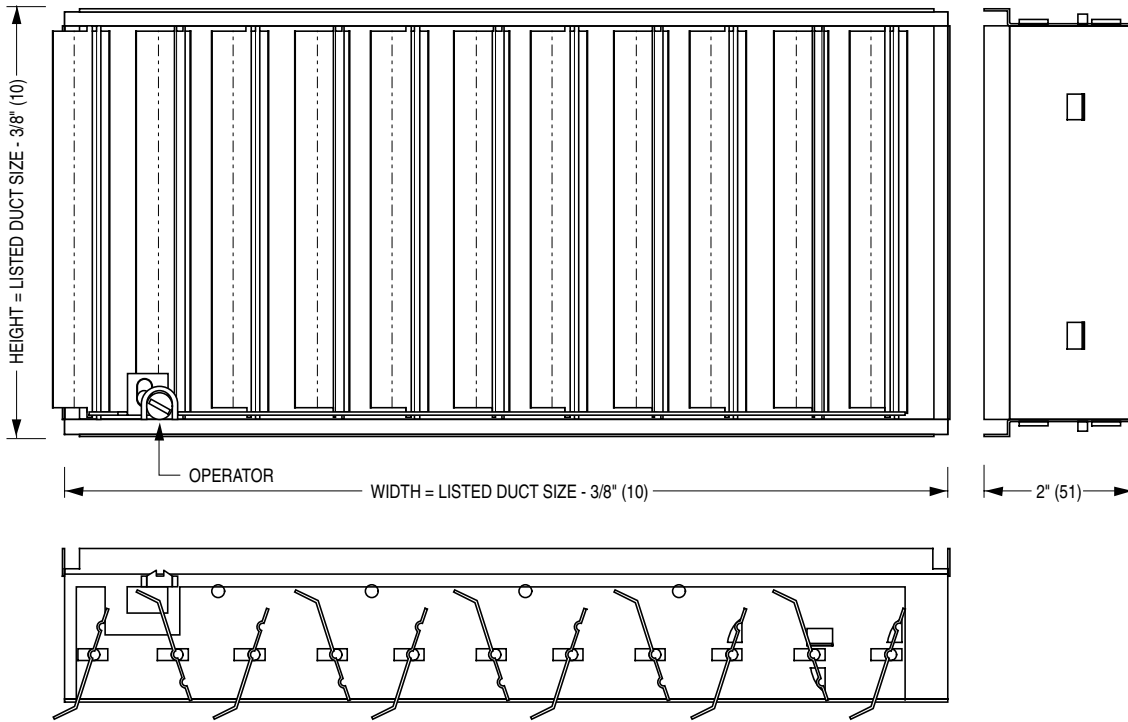

**OBD-L** Long Blades

**OBD-S** Short Blades

Minimum Size = 4" x 2 1/2" (102 x 64)

Maximum Size = 24" x 24" (610 x 610)

**DESCRIPTION:**

1. Material: Roll-formed, corrosion-resistant steel. Mill finish.
2. Designed to mount directly on the neck of a grille or diffuser in square and rectangular neck applications. Supplied with steel barbed S-clips for easy field mounting. Supplied as standard with a screwdriver slot operator.
3. Gang operated blades on 1" (25) centers move simultaneously in opposite directions and close at 45° to permit precise metering of the air with a minimal disturbance to the air pattern.

**SPECIAL FEATURES:**

\_\_\_\_\_.

**OPTIONS:**

Type PL Pivot Lever Operator.

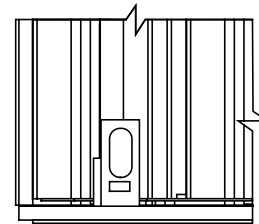

For fixed, angled deflection return grilles. Blade orientation of damper must be opposite of grille. Adjusted with a screwdriver.

<b>SCHEDULE TYPE:</b>		Dimensions are in inches (mm).			
<b>PROJECT:</b>					
<b>ENGINEER:</b>	<b>DATE</b>	<b>B SERIES</b>	<b>SUPERSEDES</b>	<b>DRAWING NO.</b>	
<b>CONTRACTOR:</b>	26 - 8 - 99RR	ACC.DIF/GR	6-94/5100-21	ACC.ABD-1	



**AIR BALANCING DEVICES  
OPPOSED BLADE DAMPER • DUCT MOUNTED  
FOR SQUARE AND RECTANGULAR NECKS  
MODEL: OBD-A TYPE SL & PL**

**TYPE SL** Screwdriver Slot Face Operator (Standard)

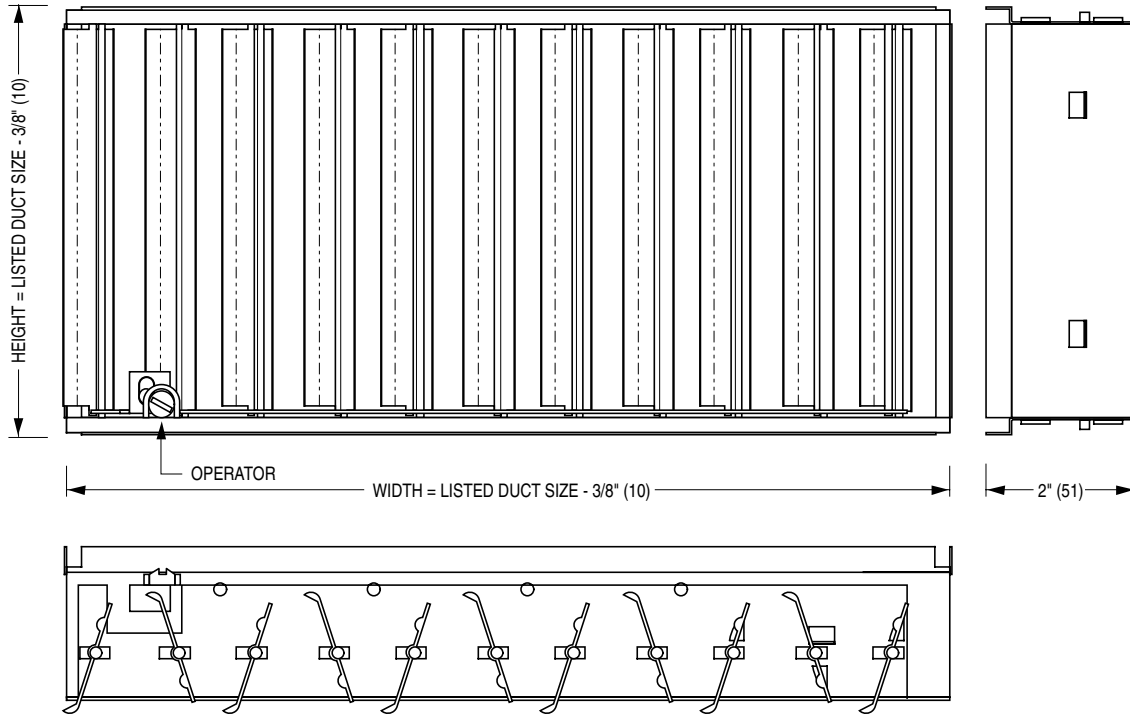

**OBD-A-L** Long Blades

**OBD-A-S** Short Blades

Minimum Size = 4" x 2 1/2" (102 x 64)

Maximum Size = 24" x 24" (610 x 610)

**DESCRIPTION:**

1. Material: Heavy gauge, extruded aluminum with miscellaneous steel components. Mill finish.
2. Designed to mount directly on the neck of a grille or diffuser in square and rectangular neck applications. Supplied with steel barbed S-clips for easy field mounting. Supplied as standard with a screwdriver slot operator.
3. Gang operated blades on 1" (25) centers move simultaneously in opposite directions and close at 45° to permit precise metering of the air with a minimal disturbance to the air pattern.

**SPECIAL FEATURES:**

\_\_\_\_\_.

**OPTIONS:**

Type PL Pivot Lever Operator.

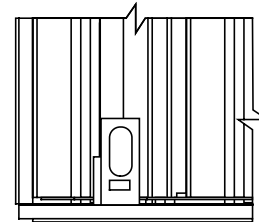

For fixed, angled deflection return grilles. Blade orientation of damper must be opposite of grille. Adjusted with a screwdriver.

<b>SCHEDULE TYPE:</b>		Dimensions are in inches (mm).			
<b>PROJECT:</b>					
<b>ENGINEER:</b>	<b>DATE</b>	<b>B SERIES</b>	<b>SUPERSEDES</b>	<b>DRAWING NO.</b>	
<b>CONTRACTOR:</b>	26 - 8 - 99RR	ACC.DIF/GR	NEW	ACC.ABD-2	



Nailor offers a selection of standard colors and finishes available on our grilles, registers and diffusers. For painted finishes, our state-of-the-art paint systems provide environmentally friendly finishing solutions with uniform coverage and coating thickness. The result is an exceptionally durable finish that resists scratching, corrosion and general wear. Additional facilities for special requirements, as well as a selection of anodized or brushed finishes, complete our ability to provide unmatched beauty and durability for any application.

**NAILOR POWDER COAT PROPERTIES**

FILM THICKNESS	2.0 to 3.0 mils
HARDNESS	2 H
IMPACT RESISTANCE	Direct: 160 inch - lbs. Reverse 160 inch - lbs.
SALT SPRAY	1000 hours

**ELECTROCOATING PROPERTIES**

FILM THICKNESS	.8 to 1.2 mils
HARDNESS	HB TO H
IMPACT RESISTANCE	80 inch - lbs
SALT SPRAY	100 hours

**POWDER COAT**

Nailor's powder coat is a high-tech thermosetting polyester powder coating with superior physical properties that provide excellent color and gloss retention. The finish offers extreme durability and hardness that resists scratching, chipping and general wear. Surface preparation includes degreasing and a chemical cleaning followed by a clean rinse before a final powder coat finish is applied and baked. The environmentally friendly Nailor powder coat system assures uniform coverage and color consistency resulting in a long lasting superior finish. Colors, including simulated anodizing, which is far more economical than color anodizing, can be selected from Nailor's standard color chart or non-standard colors and can be matched from sample chips provided to Nailor.

**ELECTROCOATING**

E-Coat is an environmentally friendly coating that provides complete coverage and a wide range of performance properties, formulated to meet corrosion, durability and other performance specifications. Electrocoating is a highly automated process in which paint is electrically deposited onto a metal foundation. Film build thickness is uniform and overall application efficiencies are in excess of 90%. Paint is consistent on all part-to-part surfaces, preventing sags, runs or drips. E-Coat offers flexibility, better first yield pass and quicker production times compared to other forms of paint applications. Electrocoating is an excellent solution that offers superior properties and uniform finish.

**CLEAR ANODIZING** (Aluminum products only)

Clear anodizing is a clear oxide coating that exemplifies an aluminum surface's natural oxide coating producing a hard, scratch resistant surface that is resistant to general wear and mild chemicals. The process provides a natural looking, virtually maintenance free finish that will endure for many years.

**COLOR ANODIZING** (Aluminum products only)

Color anodizing is an electrolytic process where, after standard anodizing procedures, colored metallic pigments penetrate the oxide surface pores producing a corrosion resistant, colorfast finish. The process results in a natural metallic appearance that requires little maintenance.

**BRUSHED AND CLEAR COAT**

Available on specific aluminum products (consult applicable product page for availability). Surface is brushed to achieve a scratch finish texture before being degreased and chemically cleaned. A clear lacquer coating is then applied to provide a durable protective finish.

**#4 BRUSHED SATIN POLISHED** (Stainless Steel products only)

Surface is polished to ASTM A480 #4 standard to achieve a bright durable finish that is resistant to mild chemicals and corrosion. A final coating is not required due to the inherent anti-corrosion properties of the stainless steel.

**PRIME COAT**

Prime coat provides a stable base for painting in the field. Surface pretreatment includes degreasing and a chemical cleaning before an alkyd prime coat is applied. After a thorough cleaning for dust, etc. that can contaminate the final finish and cause premature flaking or peeling, finish coat should be field applied as soon as possible.

**PAINT PREPARED ALUMINUM** (Aluminum products only)

Allows for field applied paint. Surface preparation includes degreasing and a chemical cleaning followed by a clean rinse. Finish coat should be field applied as soon as possible.

**MILL FINISH**

Surface is left untreated and requires cleaning, degreasing, etc. in the field before final finish can be applied if required.



**Nailor**<sup>®</sup>  
Industries Inc.

## STANDARD AND OPTIONAL FINISHES FOR GRILLES AND DIFFUSERS

The following standard colors and finishes are available on applicable Nailor air distribution products. Consult individual product pages for availability

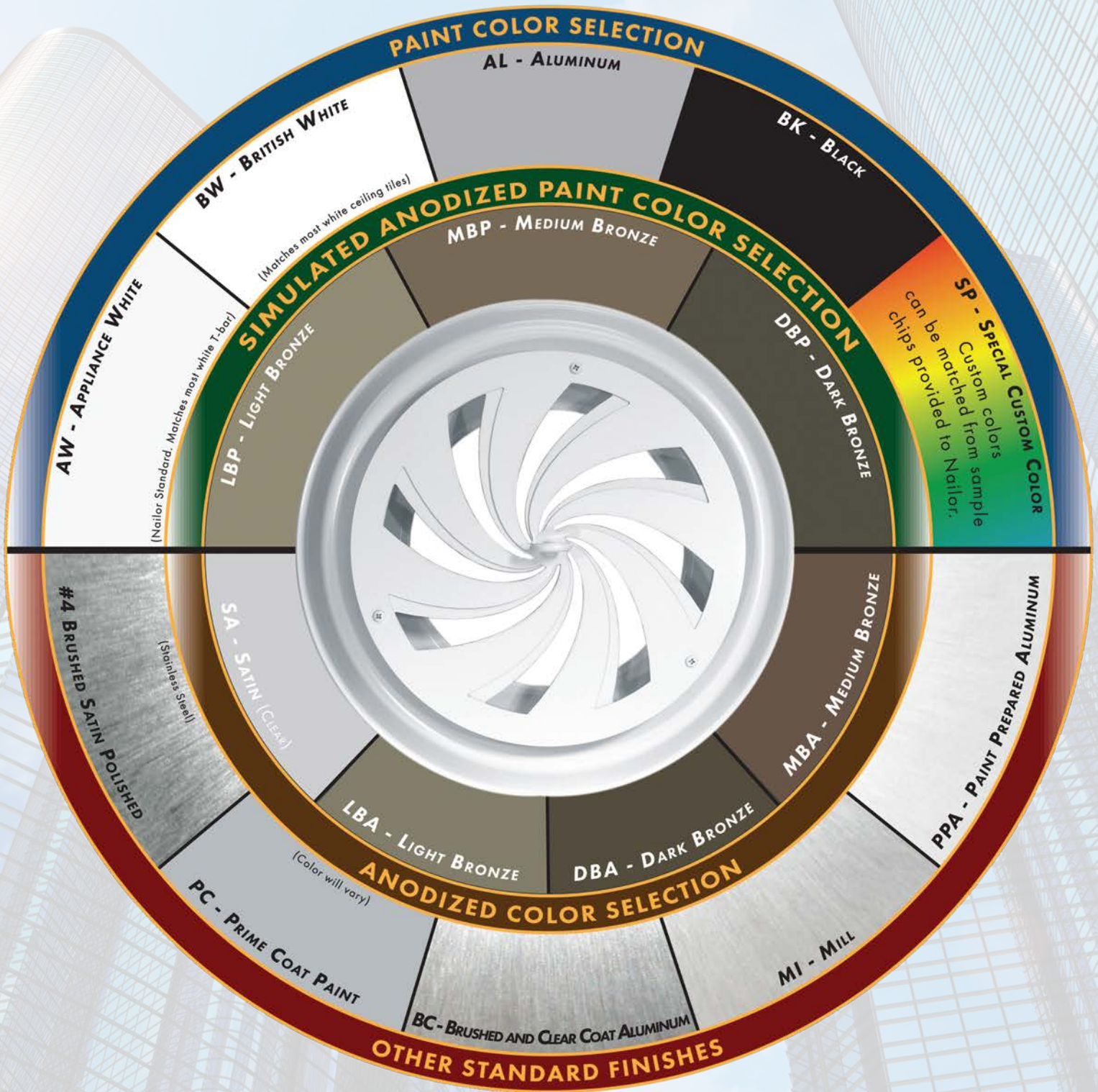

The pictured finishes have been represented as best as possible within printing limitations. However, actual finish may vary. Contact your Nailor representative for a color chip sample on the material specified for a more accurate representation.

**DBK** - Black (for registers ordered with factory mounted dampers) - **BA** - Perforated Diffusers (4300 series only) Appliance White (AW) face with black back pan and pattern controllers.

"Complete Air Control and Distribution Solutions."

WGDSOF2015

[www.nailor.com](http://www.nailor.com)

## PERFORMANCE DATA:

### Models 4260, 4260AA • Full Face • Round or Square Neck

Nominal Neck Size	Neck Velocity, FPM	300	400	500	600	700	800	900	1000	1200	1400
	Velocity Pressure	.006	.010	.016	.023	.031	.040	.051	.063	.090	.122
6" Dia.	Airflow, CFM	59	78	98	118	137	157	176	196	235	274
	Neg. Static Pressure	.011	.019	.029	.042	.056	.073	.092	.113	.162	.218
	Noise Criteria	—	—	—	—	—	—	—	16	20	29
6 x 6	Airflow, CFM	75	100	125	150	175	200	225	250	300	350
	Neg. Static Pressure	.011	.018	.029	.041	.055	.072	.091	.111	.160	.217
	Noise Criteria	—	—	—	—	—	—	16	19	23	32
8" Dia.	Airflow, CFM	105	140	175	209	244	279	314	349	419	489
	Neg. Static Pressure	.011	.019	.030	.042	.057	.074	.092	.113	.163	.218
	Noise Criteria	—	—	—	—	—	15	18	21	25	34
8 x 8	Airflow, CFM	133	178	222	267	311	356	400	444	533	622
	Neg. Static Pressure	.011	.018	.029	.042	.057	.074	.093	.115	.164	.223
	Noise Criteria	—	—	—	—	—	16	19	22	26	35
10" Dia.	Airflow, CFM	164	218	273	327	382	436	491	545	654	763
	Neg. Static Pressure	.011	.020	.031	.044	.058	.076	.095	.118	.165	.226
	Noise Criteria	—	—	—	—	15	19	22	26	32	38
10 x 10	Airflow, CFM	208	278	347	416	486	555	625	694	833	972
	Neg. Static Pressure	.011	.019	.03	.043	.058	.076	.094	.119	.169	.228
	Noise Criteria	—	—	—	—	16	20	23	27	33	39
12" Dia.	Airflow, CFM	236	314	393	471	550	628	707	785	942	1100
	Neg. Static Pressure	.011	.019	.030	.043	.058	.076	.096	.118	.170	.232
	Noise Criteria	—	—	—	—	18	22	25	28	34	41
12 x 12	Airflow, CFM	300	400	500	600	700	800	900	1000	1200	1400
	Neg. Static Pressure	.011	.020	.031	.045	.062	.08	.100	.124	.174	.239
	Noise Criteria	—	—	—	15	19	23	26	29	35	42
14" Dia.	Airflow, CFM	321	428	535	641	748	855	962	1069	1282	1497
	Neg. Static Pressure	.011	.020	.031	.044	.06	.079	.100	.123	.177	.241
	Noise Criteria	—	—	—	16	20	24	27	30	36	43
14 x 14	Airflow, CFM	408	544	681	817	953	1089	1225	1361	1633	1905
	Neg. Static Pressure	.011	.020	.032	.046	.063	.082	.103	.128	.184	.250
	Noise Criteria	—	—	—	17	21	26	29	32	38	45
16" Dia.	Airflow, CFM	419	558	698	838	977	1117	1256	1396	1675	1954
	Neg. Static Pressure	.012	.021	.032	.046	.063	.082	.104	.129	.185	.252
	Noise Criteria	—	—	—	17	21	25	29	32	38	45
16 x 16	Airflow, CFM	533	711	889	1067	1245	1422	1600	1778	2134	2489
	Neg. Static Pressure	.012	.021	.034	.048	.066	.086	.109	.134	.193	.263
	Noise Criteria	—	—	15	20	24	28	31	34	40	47
18" Dia.	Airflow, CFM	530	707	884	1060	1237	1414	1590	1767	2120	2474
	Neg. Static Pressure	.012	.021	.033	.048	.066	.086	.108	.134	.193	.262
	Noise Criteria	—	—	15	20	24	28	31	34	40	47
18 x 18	Airflow, CFM	675	900	1125	1350	1575	1800	2025	2250	2700	3150
	Neg. Static Pressure	.013	.023	.035	.051	.070	.091	.115	.142	.204	.278
	Noise Criteria	—	—	17	22	27	32	35	38	45	51
22 x 22	Airflow, CFM	1008	1344	1681	2017	2353	2689	3025	3361	4033	4706
	Neg. Static Pressure	.014	.025	.040	.057	.078	.102	.129	.159	.229	.312
	Noise Criteria	—	—	19	24	29	34	37	40	47	53

#### Performance Notes:

- All pressures are in inches w.g..
- Neck Velocity is given in feet per minute (fpm). Airflow is given in cubic feet per minute (cfm).
- Noise Criteria (NC) values are based upon 10 dB room absorption, re 10<sup>-12</sup> watts. Dash (—) in space indicates an Noise Criteria of less than 15.
- Data derived from tests conducted in accordance with ANSI/ASHRAE Standard 70 – 2006.