

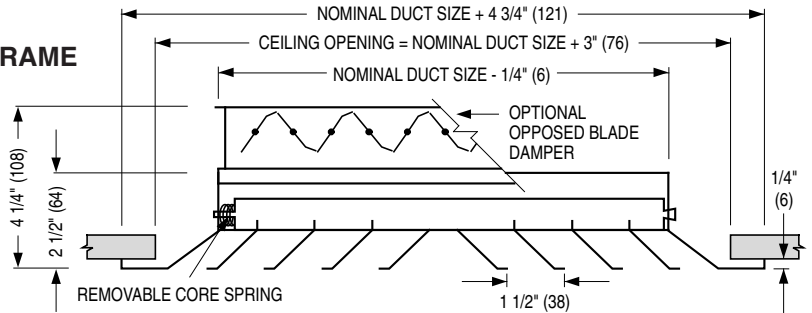

PATTERN CEILING DIFFUSERS
STEEL • SQUARE, RECTANGULAR OR
ROUND NECK
MODELS: 6500 AND 6500-O TYPES S & B

TYPE S • SURFACE MOUNT • FLAT FRAME

Minimum duct size: 6 x 6 (152 x 152)
 Maximum duct size: 36 x 36 (914 x 914)
 or 36 x 24 (914 x 610) with O.B.D.
 Available in 3" (76) increments only.



TYPE B • BEVELED DROP FACE
• SURFACE MOUNT

Minimum duct size: 6 x 6 (152 x 152)
 Maximum duct size: 36 x 36 (914 x 914)
 or 36 x 24 (914 x 610) with O.B.D.
 Available in 3" (76) increments only.

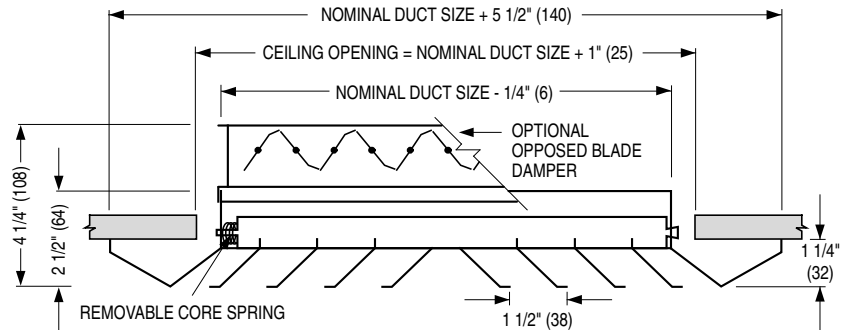

CORE STYLE SELECTION

	SQUARE	RECTANGULAR	
→ 1-WAY	<input type="checkbox"/> 1S	<input type="checkbox"/> 1A	<input type="checkbox"/> 1B
↕ 2-WAY	<input type="checkbox"/> 2S	<input type="checkbox"/> 2A	<input type="checkbox"/> 2B
↙↘ 2-WAY CORNER	<input type="checkbox"/> 2G	<input type="checkbox"/> 2E	<input type="checkbox"/> 2F
↕↔ 3-WAY	<input type="checkbox"/> 3A	<input type="checkbox"/> 3A1 (A is greater than B)	<input type="checkbox"/> 3A2 (B is less than A but greater than A/2)
	<input type="checkbox"/> 3H	<input type="checkbox"/> 3B (B is equal to A/2)	<input type="checkbox"/> 3E (B is less than A/2)
↕↔↕ 4-WAY	<input type="checkbox"/> 4A	<input type="checkbox"/> 4B	<input type="checkbox"/> 4C

Patterns are shown in plan view (looking down into inlet).

DESCRIPTION:

1. Material: Corrosion-resistant steel.
2. Model 6500 is a high capacity ceiling diffuser available in 1, 2, 3 or 4-way blow patterns to provide a tight horizontal airflow pattern from maximum to minimum airflow. Ideal for VAV applications.
3. Spring-loaded removable core.
4. Standard finish is AW Appliance White.

OPTIONS:

SQUARE AND RECTANGULAR NECK

Steel opposed blade damper. Model 6500-O.

ROUND NECK

- SR Square to round transition collar
- SR-O Square to round transition collar for use over O.B.D.
- 4275 Radial Opposed Blade Damper (round)
- 4250 Radial Sliding Blade Damper (round)
- 4675 Butterfly Damper (round)

EXTERNAL INSULATION

EX External Foil-Back Insulation, installed -R-4.2.

OPTIONAL FINISH:

SP Special. Specify _____ .

SCHEDULE TYPE:	Dimensions are in inches (mm).			
PROJECT:				
ENGINEER:	DATE	B SERIES	SUPERSEDES	DRAWING NO.
CONTRACTOR:	11 - 24 - 16	6500	5 - 11 - 15	6500-1



PATTERN CEILING DIFFUSERS
STEEL • SQUARE, RECTANGULAR OR
ROUND NECK
MODELS: 6500 AND 6500-O TYPE D

TYPE D DEEP DROP FACE

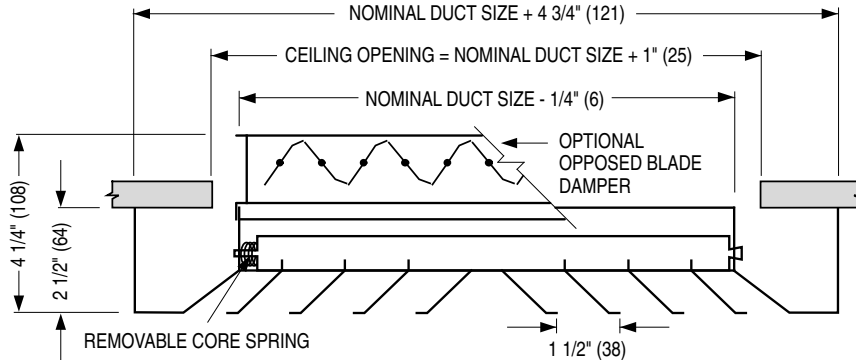

Minimum duct size: 6 x 6 (152 x 152).
 Maximum duct size: 36 x 36 (914 x 914) or 36 x 24 (914 x 610)
 with O.B.D.
 Available in 3" (76) increments only.

CORE STYLE SELECTION

	SQUARE	RECTANGULAR	
→ 1-WAY	<input type="checkbox"/> 1S	<input type="checkbox"/> 1A	<input type="checkbox"/> 1B
↕ 2-WAY	<input type="checkbox"/> 2S	<input type="checkbox"/> 2A	<input type="checkbox"/> 2B
↙↘ 2-WAY CORNER	<input type="checkbox"/> 2G	<input type="checkbox"/> 2E	<input type="checkbox"/> 2F
↕↔ 3-WAY	<input type="checkbox"/> 3A	<input type="checkbox"/> 3A1 A → ↑ B (A is greater than B)	<input type="checkbox"/> 3A2 A → ↑ B (B is less than A but greater than A/2)
		<input type="checkbox"/> 3B A → ↑ B (B is equal to A/2)	<input type="checkbox"/> 3E A → ↑ B (B is less than A/2)
		<input type="checkbox"/> 3H	
↕↔↕ 4-WAY	<input type="checkbox"/> 4A	<input type="checkbox"/> 4B	<input type="checkbox"/> 4C

Patterns are shown in plan view (looking down into inlet).

DESCRIPTION:

1. Material: Corrosion-resistant steel.
2. Model 6500 is a high capacity ceiling diffuser available in 1, 2, 3 or 4-way blow patterns to provide a tight horizontal airflow pattern from maximum to minimum airflow. Ideal for VAV applications.
3. Spring-loaded removable core.
4. Standard finish is AW Appliance White.

OPTIONS:

SQUARE AND RECTANGULAR NECK

Steel opposed blade damper. Model 6500-O.

ROUND NECK

- SR Square to round transition collar
- SR-O Square to round transition collar for use over O.B.D.
- 4275 Radial Opposed Blade Damper (round)
- 4250 Radial Sliding Blade Damper (round)
- 4675 Butterfly Damper (round)

EXTERNAL INSULATION

EX External Foil-Back Insulation, installed -R-4.2.

OPTIONAL FINISH:

SP Special. Specify _____ .

SCHEDULE TYPE:		Dimensions are in inches (mm).			
PROJECT:					
ENGINEER:	DATE	B SERIES	SUPERSEDES	DRAWING NO.	
CONTRACTOR:	11 - 24 - 16	6500	5 - 11 - 15	6500-2	



PATTERN CEILING DIFFUSER
STEEL • SQUARE OR ROUND NECK
MODELS: 6500 AND 6500-O TYPE DL

TYPE DL DROPPED FACE LAY-IN T-BAR MOUNT

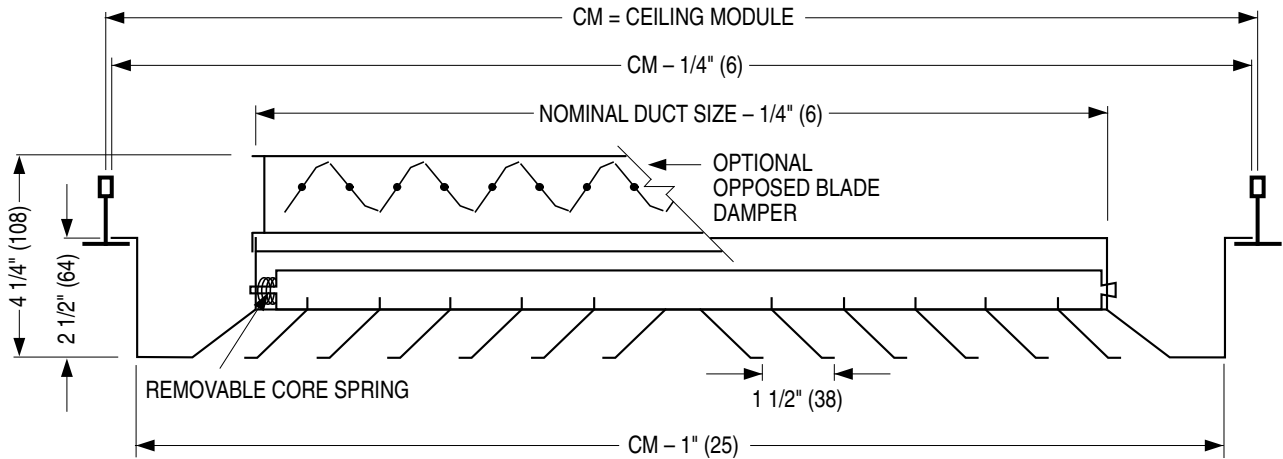

CORE STYLE SELECTION

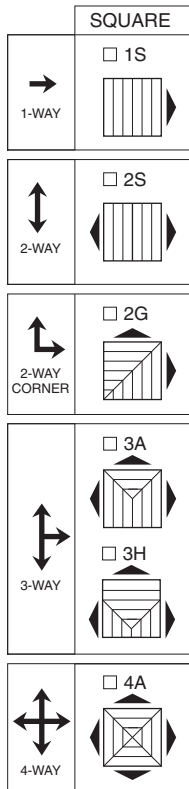

Patterns are shown in plan view (looking down into inlet).

AVAILABLE SIZES:

IMPERIAL MODULES				METRIC MODULES	
Imperial Units (in.)		Metric Units (mm)		Metric Units (mm)	
CM	Maximum Duct Size	CM	Maximum Duct Size	CM	Maximum Duct Size
24 x 24	18 x 18	610 x 610	457 x 457	600 x 600	457 x 457
48 x 24	42 x 18	1219 x 610	1067 x 457	1200 x 600	1067 x 457
48 x 48	42 x 42	1219 x 1219	1067 x 1067	1200 x 1200	1067 x 1067

Minimum duct (neck) size: 6" x 6" (152 x 152).

Maximum duct (neck) size: see table.

Available in 3" (76) increments only.

DESCRIPTION:

1. Material: Corrosion-resistant steel.
2. Model 6500 is a high capacity louvered ceiling diffuser available in 1, 2, 3 or 4-way blow patterns to provide a tight horizontal airflow pattern from maximum to minimum airflow. Ideal for VAV applications. The Type DL dropped face outer frame has been designed especially for exposed grid T-Bar ceiling systems. It provides an architecturally pleasing appearance and reduces ceiling smudging.
3. Spring-loaded removable core.
4. Standard finish is AW Appliance White.

OPTIONS:

SQUARE AND RECTANGULAR NECK

Steel opposed blade damper. Model 6500-O.

ROUND NECK

- SR Square to round transition collar
- SR-O Square to round transition collar for use over O.B.D.
- 4275 Radial Opposed Blade Damper (round)
- 4250 Radial Sliding Blade Damper (round)

EXTERNAL INSULATION

EX External Foil-Back Insulation, installed - R-4.2.

OPTIONAL FINISH:

SP Special. Specify _____ .

SCHEDULE TYPE:		Dimensions are in inches (mm).			
PROJECT:					
ENGINEER:	DATE	B SERIES	SUPERSEDES	DRAWING NO.	
CONTRACTOR:	11 - 24 - 16	6500	3 - 1 - 16	6500-2A	



PATTERN CEILING DIFFUSERS
STEEL • SQUARE, RECTANGULAR OR
ROUND NECK
MODELS: 6500 AND 6500-O TYPE L

TYPE L LAY-IN T-BAR

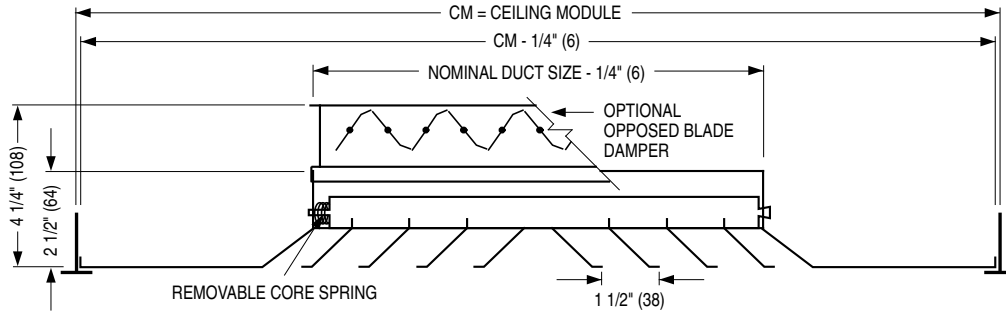

If the ceiling module is not 3" (76) or 6" (152) larger than the neck size of the diffuser in both dimensions, a module sized extended panel will be added.
 Minimum duct size: 6 x 6 (152 x 152).
 Maximum duct size: see table.
 Available in 3" (76) increments only.

IMPERIAL MODULES				METRIC MODULES	
Imperial Units (in.)		Metric Units (mm)		Metric Units (mm)	
CM	Maximum Duct Size	CM	Maximum Duct Size	CM	Maximum Duct Size
12 x 12	9 x 9	305 x 305	229 x 229	300 x 300	152 x 152
20 x 20	15 x 15	508 x 508	381 x 381	500 x 500	381 x 381
24 x 12	21 x 9	610 x 305	533 x 229	600 x 300	457 x 152
24 x 24	21 x 21	610 x 610	533 x 533	600 x 600	457 x 457
48 x 24	45 x 21	1219 x 610	1143 x 533	1200 x 600	1067 x 457

CORE STYLE SELECTION

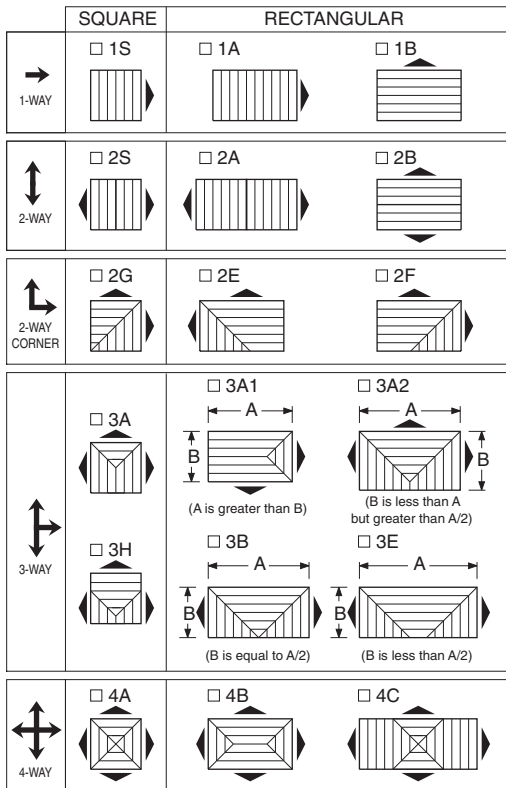

DESCRIPTION:

1. Material: Corrosion-resistant steel.
2. Model 6500 is a high capacity ceiling diffuser available in 1, 2, 3 or 4-way blow patterns to provide a tight horizontal airflow pattern from maximum to minimum airflow. Ideal for VAV applications.
3. Spring-loaded removable core.
4. Standard finish is AW Appliance White.

OPTIONS:

SQUARE AND RECTANGULAR NECK

Steel opposed blade damper. Model 6500-O.

ROUND NECK

- SR Square to round transition collar
- SR-O Square to round transition collar for use over O.B.D.
- 4275 Radial Opposed Blade Damper (round)
- 4250 Radial Sliding Blade Damper (round)
- 4675 Butterfly Damper (round)

EXTERNAL INSULATION

- EX External Foil-Back Insulation, installed -R-4.2.
- MIB Molded Insulation Blanket, -R-6.0. ('MIB' is available for Frame Types L, TL and F with a 24 x 24 CM only, 15 x 15 max. neck size and a 'SR' square-to-round transition collar).

OPTIONAL FINISH:

SP Special. Specify _____.

Patterns are shown in plan view (looking down into inlet).

SCHEDULE TYPE:	Dimensions are in inches (mm).			
PROJECT:				
ENGINEER:	DATE	B SERIES	SUPERSEDES	DRAWING NO.
CONTRACTOR:	2 - 8 - 18	6500	1 - 16 - 17	6500-3



PATTERN CEILING DIFFUSERS
STEEL • SQUARE, RECTANGULAR OR
ROUND NECK
MODELS: 6500 AND 6500-O TYPE SP

TYPE SP SPLINE

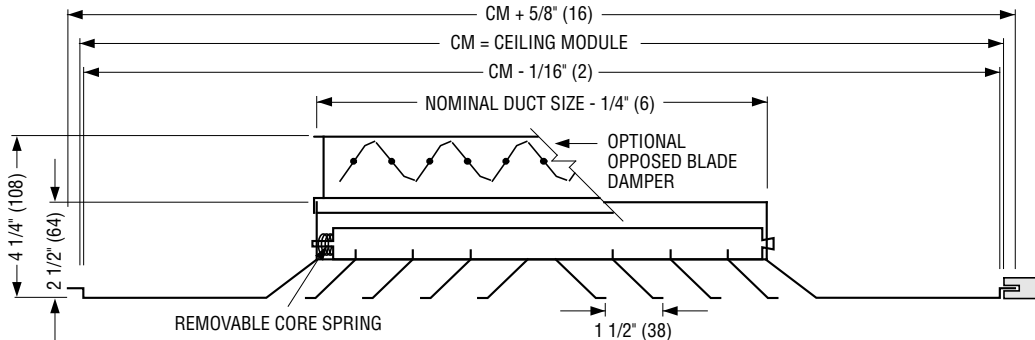

If the ceiling module is not 3" (76) larger than the neck size of the diffuser in both dimensions, a module sized extended panel will be added.

Minimum duct size: 6 x 6 (152 x 152).

Maximum duct size: see table.

Available in 3" (76) increments only.

IMPERIAL MODULES				METRIC MODULES	
Imperial Units (in.)		Metric Units (mm)		Metric Units (mm)	
CM	Maximum Duct Size	CM	Maximum Duct Size	CM	Maximum Duct Size
12 x 12	9 x 9	305 x 305	229 x 229	300 x 300	152 x 152
20 x 20	15 x 15	508 x 508	381 x 381	500 x 500	381 x 381
24 x 12	21 x 9	610 x 305	533 x 229	600 x 300	457 x 152
24 x 24	21 x 21	610 x 610	533 x 533	600 x 600	457 x 457
48 x 24	45 x 21	1219 x 610	1143 x 533	1200 x 600	1067 x 457

CORE STYLE SELECTION

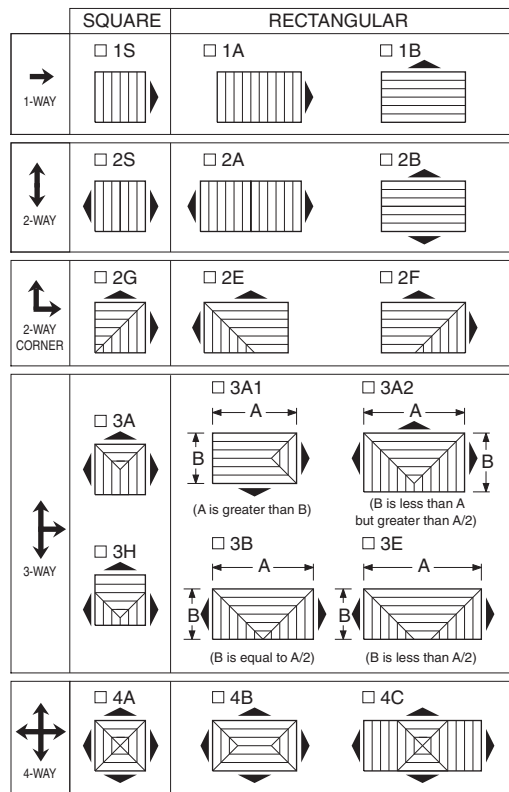

Patterns are shown in plan view (looking down into inlet).

Spline Type Diffuser for one-directional exposed T-bar lay-in grid or for concealed T-bar grid (splines on two opposite sides - steel lift brackets on other two sides).

DESCRIPTION:

1. Material: Corrosion-resistant steel.
2. Model 6500 is a high capacity ceiling diffuser available in 1, 2, 3 or 4-way blow patterns to provide a tight horizontal airflow pattern from maximum to minimum airflow. Ideal for VAV applications.
3. Spring-loaded removable core.
4. Standard finish is AW Appliance White.

OPTIONS:

SQUARE AND RECTANGULAR NECK

Steel opposed blade damper. Model 6500-O.

ROUND NECK

- SR Square to round transition collar
- SR-O Square to round transition collar for use over O.B.D.
- 4275 Radial Opposed Blade Damper (round)
- 4250 Radial Sliding Blade Damper (round)
- 4675 Butterfly Damper (round)

EXTERNAL INSULATION

EX External Foil-Back Insulation, installed -R-4.2.

OPTIONAL FINISH:

SP Special. Specify _____ .

SCHEDULE TYPE:	Dimensions are in inches (mm).			
PROJECT:				
ENGINEER:	DATE	B SERIES	SUPERSEDES	DRAWING NO.
CONTRACTOR:	2 - 8 - 18	6500	11 - 24 - 16	6500-4



PATTERN CEILING DIFFUSERS
STEEL • SQUARE, RECTANGULAR OR
ROUND NECK
MODELS: 6500 AND 6500-O TYPE F

FOR FINELINE® TYPE CEILING SYSTEMS

TYPE F FINELINE® T-BAR

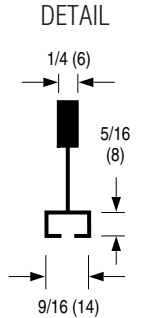
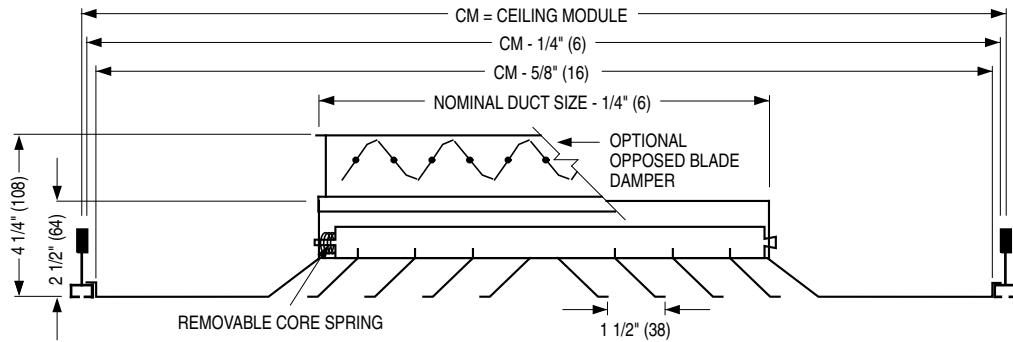

The diffuser is supplied in a module size extended panel.
 Minimum duct size: 6 x 6 (152 x 152).
 Maximum duct size: see table.
 Available in 3" (76) increments only.

IMPERIAL MODULES				METRIC MODULES	
Imperial Units (in.)		Metric Units (mm)		Metric Units (mm)	
CM	Maximum Duct Size	CM	Maximum Duct Size	CM	Maximum Duct Size
12 x 12	6 x 6	305 x 305	152 x 152	300 x 300	152 x 152
24 x 12	18 x 6	610 x 305	457 x 152	600 x 300	457 x 152
24 x 24	18 x 18	610 x 610	457 x 457	600 x 600	457 x 457

CORE STYLE SELECTION

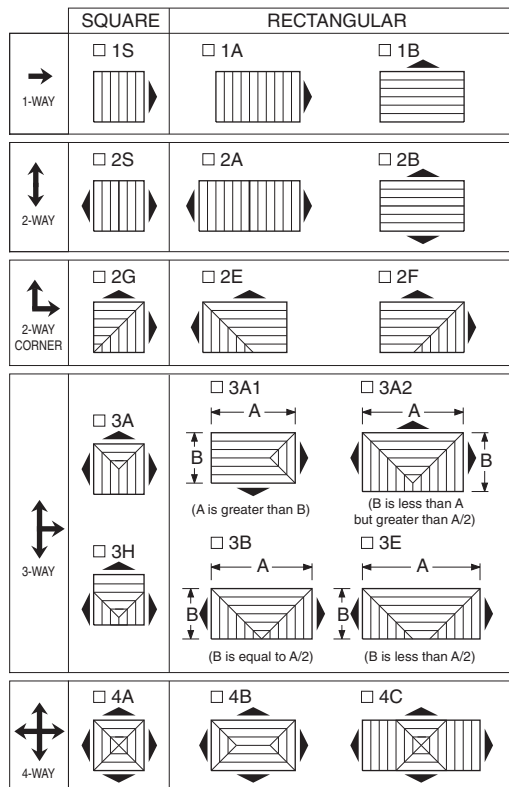

Patterns are shown in plan view (looking down into inlet).

DESCRIPTION:

1. Material: Corrosion-resistant steel.
2. Model 6500 is a high capacity ceiling diffuser available in 1, 2, 3 or 4-way blow patterns to provide a tight horizontal airflow pattern from maximum to minimum airflow. Ideal for VAV applications.
3. Spring-loaded removable core.
4. Standard finish is AW Appliance White.

OPTIONS:

SQUARE AND RECTANGULAR NECK

Steel opposed blade damper. Model 6500-O.

ROUND NECK

- SR Square to round transition collar
- SR-O Square to round transition collar for use over O.B.D.
- 4275 Radial Opposed Blade Damper (round)
- 4250 Radial Sliding Blade Damper (round)
- 4675 Butterfly Damper (round)

EXTERNAL INSULATION

- EX External Foil-Back Insulation, installed -R-4.2.
- MIB Molded Insulation Blanket, -R-6.0. ('MIB' is available for Frame Types L, TL and F with a 24 x 24 CM only, 15 x 15 max. neck size and a 'SR' square-to-round transition collar).

OPTIONAL FINISH:

SP Special. Specify _____.

Fineline® is a registered trademark of USG Interiors Inc..

Dimensions are in inches (mm).

SCHEDULE TYPE:				
PROJECT:				
ENGINEER:	DATE	B SERIES	SUPERSEDES	DRAWING NO.
CONTRACTOR:	1 - 16 - 17	6500	8 - 17 - 16	6500-5



PATTERN CEILING DIFFUSERS
STEEL • SQUARE, RECTANGULAR OR
ROUND NECK
MODELS: 6500 AND 6500-O TYPE TL

TYPE TL
REGULAR LAY-IN

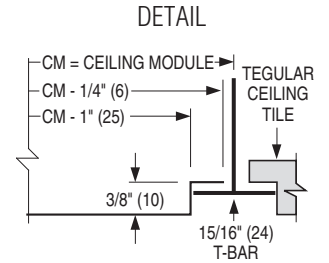
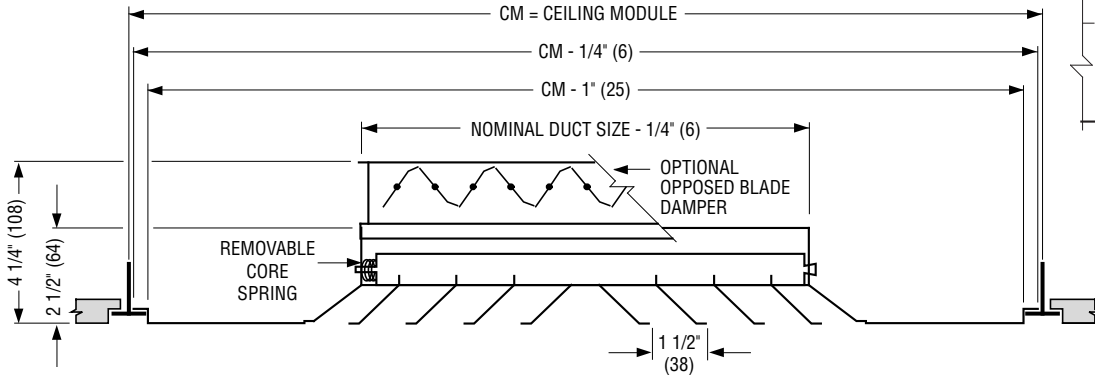

Minimum duct size: 6 x 6 (152 x 152).
 Maximum duct size: see table.
 Available in 3" (76) increments only.

IMPERIAL MODULES		METRIC MODULES		METRIC MODULES	
Imperial Units (in.)	Maximum Duct Size	Metric Units (mm)	Maximum Duct Size	Metric Units (mm)	Maximum Duct Size
CM		CM		CM	
12 x 12	6 x 6	305 x 305	152 x 152	300 x 300	152 x 152
24 x 12	18 x 6	610 x 305	457 x 152	600 x 300	457 x 152
24 x 24	18 x 18	610 x 610	457 x 457	600 x 600	457 x 457

CORE STYLE SELECTION

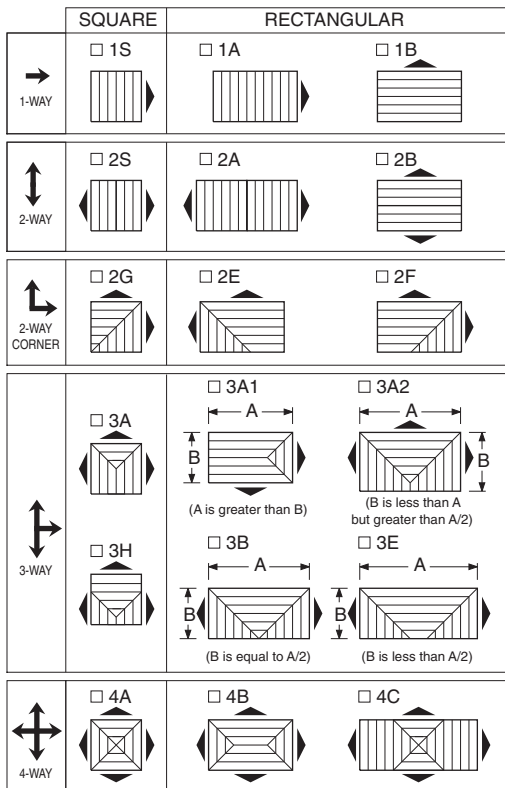

Patterns are shown in plan view (looking down into inlet).

DESCRIPTION:

1. Material: Corrosion-resistant steel.
2. Model 6500 is a high capacity ceiling diffuser available in 1, 2, 3 or 4-way blow patterns to provide a tight horizontal airflow pattern from maximum to minimum airflow. Ideal for VAV applications.

The diffuser is supplied in a module sized extended panel which drops the diffuser face below the T-bar so that it is flush with the tegular ceiling panels.

3. Spring-loaded removable core.
4. Standard finish is AW Appliance White.

OPTIONS:

SQUARE AND RECTANGULAR NECK

- Steel opposed blade damper. Model 6500-O.

ROUND NECK

- SR Square to round transition collar
- SR-O Square to round transition collar for use over O.B.D.
- 4275 Radial Opposed Blade Damper (round)
- 4250 Radial Sliding Blade Damper (round)
- 4675 Butterfly Damper (round)

EXTERNAL INSULATION

- EX External Foil-Back Insulation, installed -R-4.2.
- MIB Molded Insulation Blanket, -R-6.0. ('MIB' is available for Frame Types L, TL and F with a 24 x 24 CM only, 15 x 15 max. neck size and a 'SR' square-to-round transition collar).

OPTIONAL FINISH:

- SP Special. Specify _____.

SCHEDULE TYPE:

PROJECT:

ENGINEER:

CONTRACTOR:

Dimensions are in inches (mm).

DATE

B SERIES

SUPERSEDES

DRAWING NO.

1 - 16 - 17

6500

8 - 17 - 16

6500-6



PATTERN CEILING DIFFUSERS
STEEL • SQUARE, RECTANGULAR OR
ROUND NECK
MODELS: 6500 AND 6500-O TYPE M

TYPE M METAL PAN (SNAP-IN)

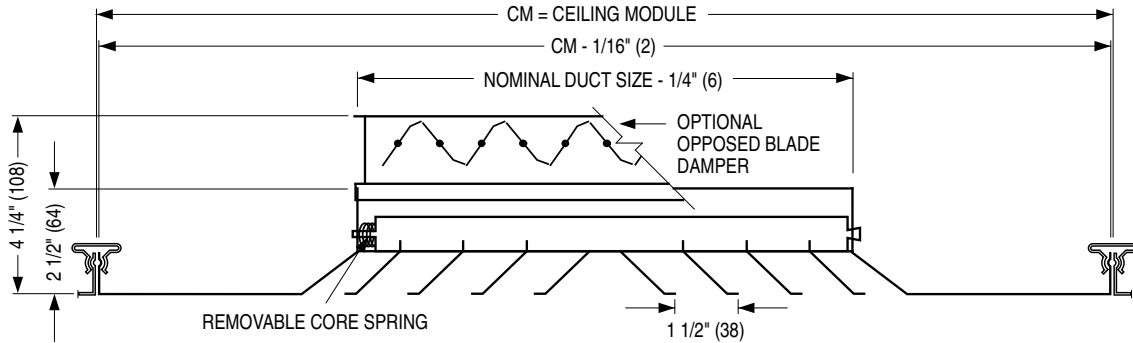

If the ceiling module is not 3" (76) larger than the neck size of the diffuser in both dimensions, a module sized extended panel will be added.
 Minimum duct size: 6 x 6 (152 x 152).
 Maximum duct size: see table.
 Available in 3" (76) increments only.

IMPERIAL MODULES				METRIC MODULES	
Imperial Units (in.)		Metric Units (mm)		Metric Units (mm)	
CM	Maximum Duct Size	CM	Maximum Duct Size	CM	Maximum Duct Size
12 x 12	9 x 9	305 x 305	229 x 229	300 x 300	152 x 152
24 x 12	21 x 9	610 x 305	533 x 229	600 x 300	457 x 152
24 x 24	21 x 21	610 x 610	533 x 533	600 x 600	457 x 457

CORE STYLE SELECTION

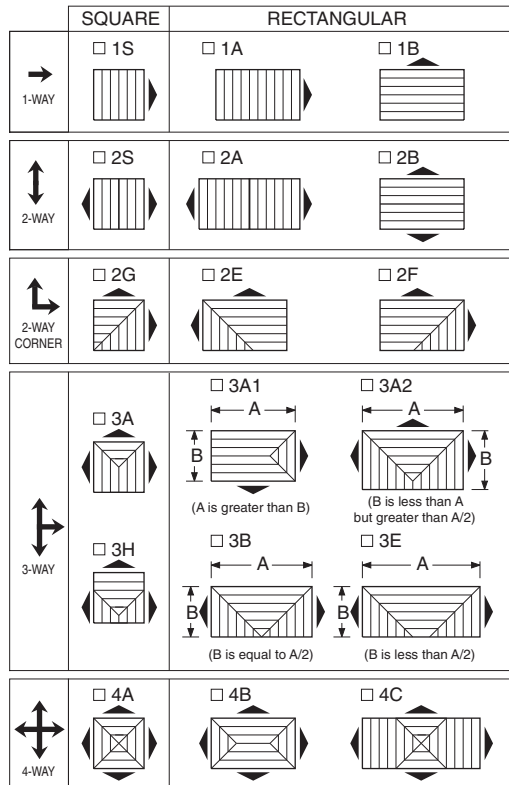

Patterns are shown in plan view (looking down into inlet).

DESCRIPTION:

1. Material: Corrosion-resistant steel.
2. Model 6500 is a high capacity ceiling diffuser available in 1, 2, 3 or 4-way blow patterns to provide a tight horizontal airflow pattern from maximum to minimum airflow. Ideal for VAV applications.
3. Spring-loaded removable core.
4. Standard finish is AW Appliance White.

OPTIONS:

SQUARE AND RECTANGULAR NECK

Steel opposed blade damper. Model 6500-O.

ROUND NECK

- SR Square to round transition collar
- SR-O Square to round transition collar for use over O.B.D.
- 4275 Radial Opposed Blade Damper (round)
- 4250 Radial Sliding Blade Damper (round)
- 4675 Butterfly Damper (round)

EXTERNAL INSULATION

EX External Foil-Back Insulation, installed-R-4.2.

OPTIONAL FINISH:

SP Special. Specify _____.

SCHEDULE TYPE:

PROJECT:

ENGINEER:

CONTRACTOR:

Dimensions are in inches (mm).

DATE

B SERIES

SUPERSEDES

DRAWING NO.

2 - 8 - 18

6500

11 - 24 - 16

6500-7



PATTERN CEILING DIFFUSER
STEEL LOUVERED FACE • FIBERGLASS
PLENUM • 24" x 24" MODULE FOR T-BAR CEILINGS
MODEL: 6500FP TYPE L

TYPE L LAY-IN T-BAR

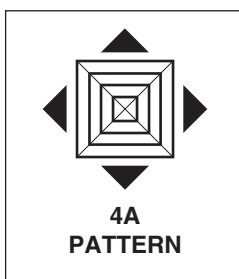
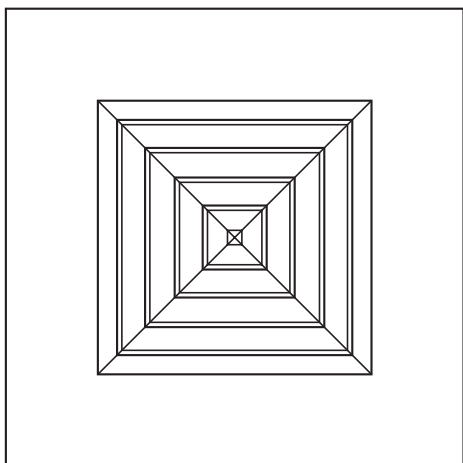
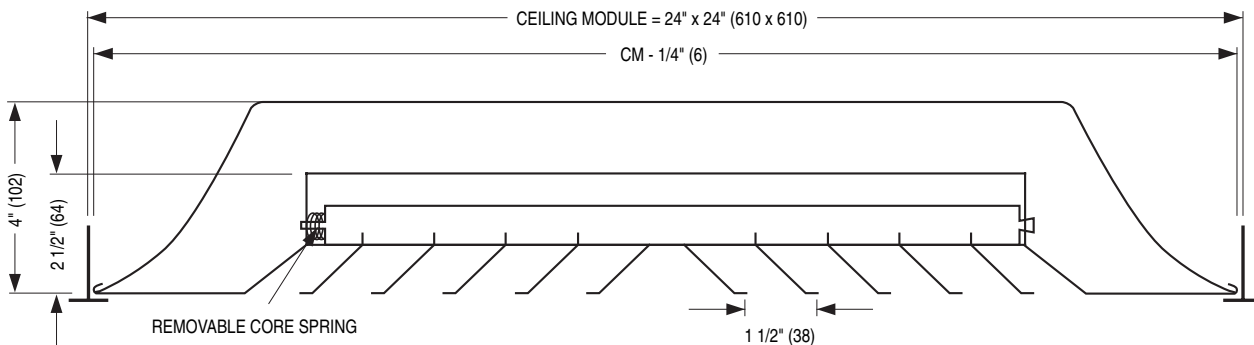

DESCRIPTION:

1. Corrosion-resistant steel diffuser face and core assembly. One piece molded fiberglass backpan with foil back vapour barrier. 6.0 R-value.
2. Model 6500FP is a high capacity ceiling diffuser with a 4-way blow pattern that provides a tight horizontal airflow pattern from maximum to minimum airflow. Ideal for VAV applications.
3. Spring-loaded 15" x 15" (381 x 381) removable core.
4. Pre-scored plenum for 6", 8", 10", 12", 14" or 15" (152, 203, 254, 305, 356 or 381) dia. spin-in or tab lock inlet collar (by others).
5. Standard finish is AW Appliance White.

ACCESSORIES (OPTIONAL):

- 4275 Radial Opposed Blade Damper.
 - 4250 Radial Sliding Blade Damper.
- Finish
- SP Special. Specify _____.

SCHEDULE TYPE:	
PROJECT:	
ENGINEER:	
CONTRACTOR:	

Dimensions are in inches (mm).

DATE	B SERIES	SUPERSEDES	DRAWING NO.
3 - 12 - 10	6500FP	NEW	6500FP-1



**PATTERN CEILING DIFFUSERS
WITH IV INDUCTION VANES**
STEEL • SQUARE, RECTANGULAR OR ROUND NECK
MODELS: 6500IV AND 6500IV-O TYPES S & B

OFFSET NECK OPTION

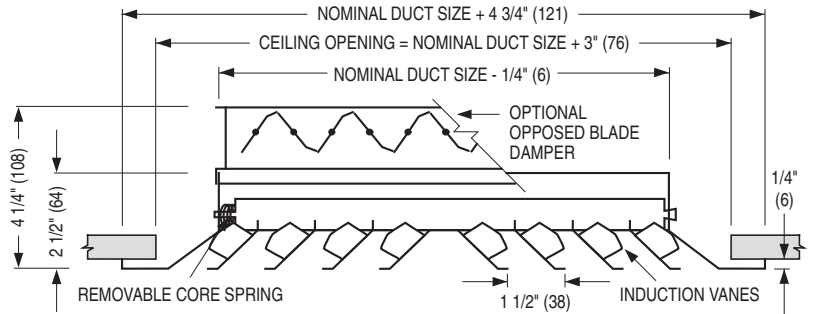
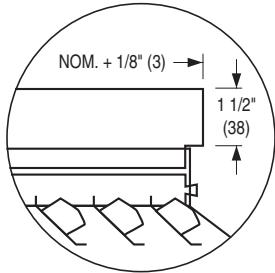

TYPE S • SURFACE MOUNT • FLAT FRAME

Minimum duct size: 6 x 6 (152 x 152)
Maximum duct size: 36 x 36 (914 x 914) or
36 x 24 (914 x 610) with O.B.D.
Available in 3" (76) increments only.

TYPE B • BEVELED DROP FACE • SURFACE MOUNT

Minimum duct size: 6 x 6 (152 x 152)
Maximum duct size: 36 x 36 (914 x 914) or
36 x 24 (914 x 610) with O.B.D.
Available in 3" (76) increments only.

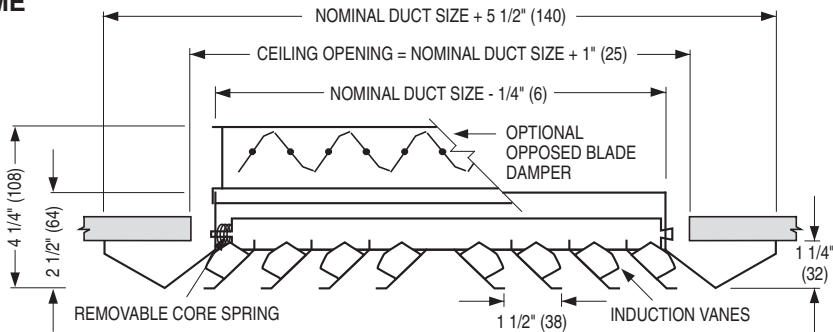

CORE STYLE SELECTION

	SQUARE	RECTANGULAR	
→ 1-WAY	<input type="checkbox"/> 1S	<input type="checkbox"/> 1A	<input type="checkbox"/> 1B
↕ 2-WAY	<input type="checkbox"/> 2S	<input type="checkbox"/> 2A	<input type="checkbox"/> 2B
↙ 2-WAY CORNER	<input type="checkbox"/> 2G	<input type="checkbox"/> 2E	<input type="checkbox"/> 2F
↕ 3-WAY	<input type="checkbox"/> 3A	<input type="checkbox"/> 3A1 (A is greater than B)	<input type="checkbox"/> 3A2 (B is less than A but greater than A/2)
		<input type="checkbox"/> 3B (B is equal to A/2)	<input type="checkbox"/> 3E (B is less than A/2)
↕ 4-WAY	<input type="checkbox"/> 4A	<input type="checkbox"/> 4B	<input type="checkbox"/> 4C

Patterns are shown in plan view (looking down into inlet).

DESCRIPTION:

1. Material: Corrosion-resistant steel.
2. Model 6500IV is a high capacity ceiling diffuser available in 1, 2, 3 or 4-way blow patterns to provide a tight horizontal airflow pattern from maximum to minimum airflow. The induction vanes consist of a set of 45° angled diffusion vanes spaced 1 1/2" (38) apart on the back of each diffuser louver. Vane sets on adjacent parallel louvers run in opposite directions and cause primary air to emerge from each louver at alternating angles. The resulting turbulent discharge air jets produce high induction rates and rapid temperature equalization, making the diffuser eminently suitable for VAV applications as the possibility of downdrafts (dumping) are eliminated.
3. Spring-loaded removable core.
4. Standard finish is AW Appliance White.

OPTIONS:

SQUARE AND RECTANGULAR NECK

- Steel opposed blade damper. Model 6500IV-O.
- ONA Offset neck adaptor. Fits outside duct (if a damper is required, order separately for remote mount. See Model OBDD).

ROUND NECK

- SR Square to round transition collar
- SR-O Square to round transition collar for use over O.B.D.
- 4275 Radial Opposed Blade Damper (round)
- 4250 Radial Sliding Blade Damper (round)
- 4675 Butterfly Damper (round)

EXTERNAL INSULATION

- EX External Foil-Back Insulation, installed - R - 4.2.

OPTIONAL FINISH:

- SP Special. Specify _____ .

Dimensions are in inches (mm).

SCHEDULE TYPE:

PROJECT:

ENGINEER:

CONTRACTOR:

DATE

B SERIES

SUPERSEDES

DRAWING NO.

11 - 24 - 16

6500

2 - 12 - 16

6500IV-1

PATTERN CEILING DIFFUSERS WITH IV INDUCTION VANES

STEEL • SQUARE, RECTANGULAR OR ROUND NECK
MODELS: 6500IV AND 6500IV-O TYPE D

OFFSET NECK OPTION

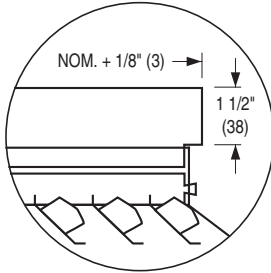

TYPE D • DEEP DROP FACE

Minimum duct size: 6 x 6 (152 x 152)
 Maximum duct size: 36 x 36 (914 x 914) or
 36 x 24 (914 x 610) with O.B.D.
 Available in 3" (76) increments only.

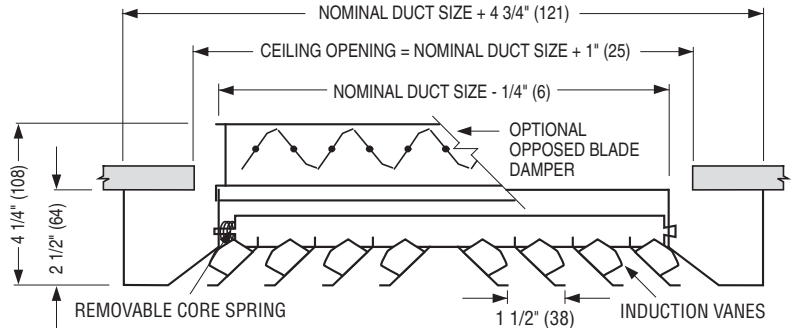

CORE STYLE SELECTION

	SQUARE	RECTANGULAR	
→ 1-WAY	<input type="checkbox"/> 1S	<input type="checkbox"/> 1A	<input type="checkbox"/> 1B
↕ 2-WAY	<input type="checkbox"/> 2S	<input type="checkbox"/> 2A	<input type="checkbox"/> 2B
↙ 2-WAY CORNER	<input type="checkbox"/> 2G	<input type="checkbox"/> 2E	<input type="checkbox"/> 2F
↕ 3-WAY	<input type="checkbox"/> 3A	<input type="checkbox"/> 3A1 A > B	<input type="checkbox"/> 3A2 B < A but > A/2
		<input type="checkbox"/> 3B B = A/2	<input type="checkbox"/> 3E B < A/2
↕ 4-WAY	<input type="checkbox"/> 4A	<input type="checkbox"/> 4B	<input type="checkbox"/> 4C

Patterns are shown in plan view (looking down into inlet).

DESCRIPTION:

1. Material: Corrosion-resistant steel.
2. Model 6500IV is a high capacity ceiling diffuser available in 1, 2, 3 or 4-way blow patterns to provide a tight horizontal airflow pattern from maximum to minimum airflow. The induction vanes consist of a set of 45° angled diffusion vanes spaced 1 1/2" (38) apart on the back of each diffuser louver. Vane sets on adjacent parallel louvers run in opposite directions and cause primary air to emerge from each louver at alternating angles. The resulting turbulent discharge air jets produce high induction rates and rapid temperature equalization, making the diffuser eminently suitable for VAV applications as the possibility of downdrafts (dumping) are eliminated.
3. Spring-loaded removable core.
4. Standard finish is AW Appliance White.

OPTIONS:

SQUARE AND RECTANGULAR NECK

- Steel opposed blade damper. Model 6500IV-O.
- ONA Offset neck adaptor. Fits outside duct (if a damper is required, order separately for remote mount. See Model OBDD).

ROUND NECK

- SR Square to round transition collar
- SR-O Square to round transition collar for use over O.B.D.
- 4275 Radial Opposed Blade Damper (round)
- 4250 Radial Sliding Blade Damper (round)
- 4675 Butterfly Damper (round)

EXTERNAL INSULATION

- EX External Foil-Back Insulation, installed -R-4.2.

OPTIONAL FINISH:

- SP Special. Specify _____.

SCHEDULE TYPE:

PROJECT:

ENGINEER:

CONTRACTOR:

Dimensions are in inches (mm).

DATE

B SERIES

SUPERSEDES

DRAWING NO.

11 - 24 - 16

6500

2 - 12 - 16

6500IV-2



**PATTERN CEILING DIFFUSERS
WITH IV INDUCTION VANES**
STEEL • SQUARE, RECTANGULAR OR ROUND NECK
MODELS: 6500IV AND 6500IV-O TYPE L

OFFSET NECK OPTION

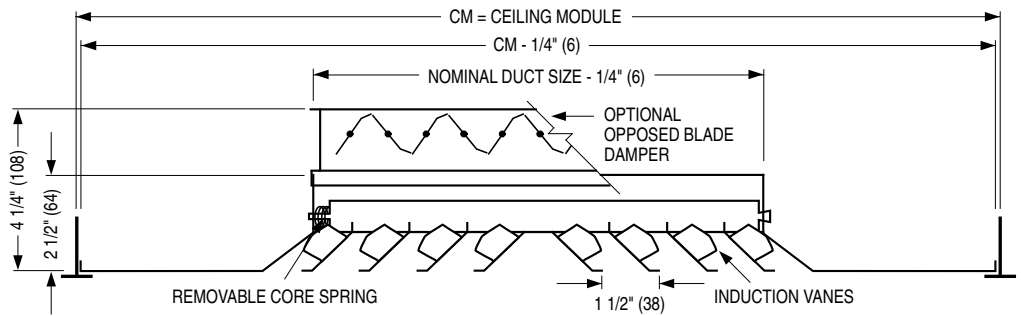
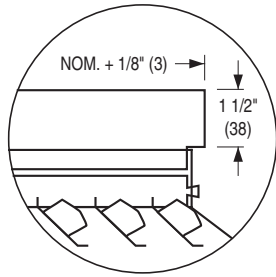

TYPE L • LAY-IN T-BAR

If the ceiling module is not 3" (76) or 6" (152) larger than the neck size of the diffuser in both dimensions, a module sized extended panel will be added.
Minimum duct size: 6 x 6 (152 x 152)
Maximum duct size: see table.
Available in 3" (76) increments only.

IMPERIAL MODULES				METRIC MODULES	
Imperial Units (in.)		Metric Units (mm)		Metric Units (mm)	
CM	Maximum Duct Size	CM	Maximum Duct Size	CM	Maximum Duct Size
12 x 12	9 x 9	305 x 305	229 x 229	300 x 300	152 x 152
20 x 20	15 x 15	508 x 508	381 x 381	500 x 500	381 x 381
24 x 12	21 x 9	610 x 305	533 x 229	600 x 300	457 x 152
24 x 24	21 x 21	610 x 610	533 x 533	600 x 600	457 x 457
48 x 24	45 x 21	1219 x 610	1143 x 533	1200 x 600	1067 x 457

CORE STYLE SELECTION

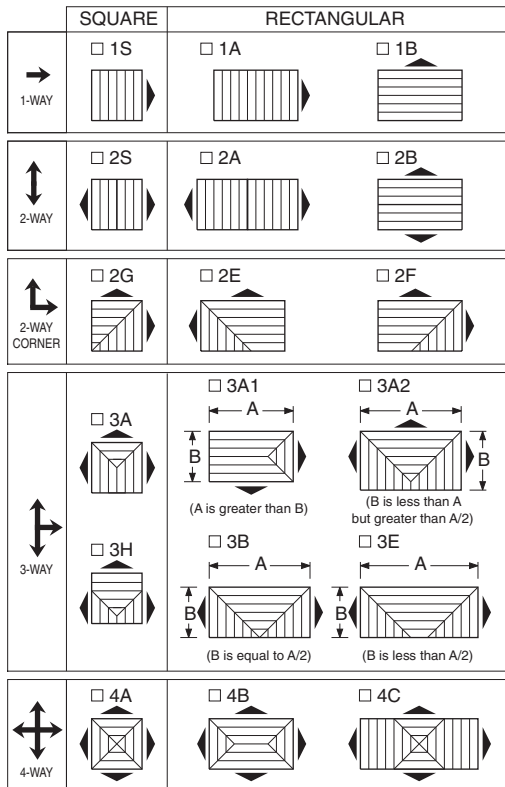

Patterns are shown in plan view (looking down into inlet).

DESCRIPTION:

1. Material: Corrosion-resistant steel.
2. Model 6500IV is a high capacity ceiling diffuser available in 1, 2, 3 or 4-way blow patterns to provide a tight horizontal airflow pattern from maximum to minimum airflow. The induction vanes consist of a set of 45° angled diffusion vanes spaced 1 1/2" (38) apart on the back of each diffuser louver. Vane sets on adjacent parallel louvers run in opposite directions and cause primary air to emerge from each louver at alternating angles. The resulting turbulent discharge air jets produce high induction rates and rapid temperature equalization, making the diffuser eminently suitable for VAV applications as the possibility of downdrafts (dumping) are eliminated.
3. Spring-loaded removable core.
4. Standard finish is AW Appliance White.

OPTIONS:

SQUARE AND RECTANGULAR NECK

- Steel opposed blade damper. Model 6500IV-O.
- ONA Offset neck adaptor. Fits outside duct (if a damper is required, order separately for remote mount. See Model OBDD).

ROUND NECK

- SR Square to round transition collar
- SR-O Square to round transition collar for use over O.B.D.
- 4275 Radial Opposed Blade Damper (round)
- 4250 Radial Sliding Blade Damper (round)
- 4675 Butterfly Damper (round)

EXTERNAL INSULATION

- EX External Foil-Back Insulation, installed -R-4.2.
- MIB Molded Insulation Blanket, -R-6.0. ('MIB' is available for Frame Types L, TL and F with a 24 x 24 CM only, 15 x 15 max. neck size and a 'SR' Square-to-round transition collar).

OPTIONAL FINISH:

- SP Special. Specify _____ .

SCHEDULE TYPE:	Dimensions are in inches (mm).			
PROJECT:				
ENGINEER:	DATE	B SERIES	SUPERSEDES	DRAWING NO.
CONTRACTOR:	2 - 8 - 18	6500	1 - 16 - 17	6500IV-3



**PATTERN CEILING DIFFUSERS
WITH IV INDUCTION VANES**
STEEL • SQUARE, RECTANGULAR OR ROUND NECK
MODELS: 6500IV AND 6500IV-O TYPE SP

OFFSET NECK OPTION

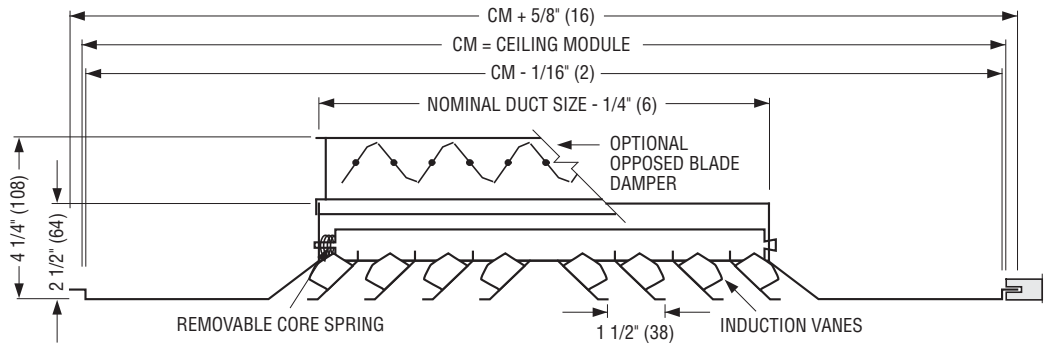
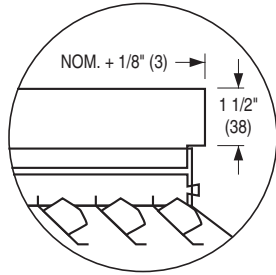

TYPE SP • SPLINE

If the ceiling module is not 3" (76) larger than the neck size of the diffuser in both dimensions, a module sized extended panel will be added.
Minimum duct size: 6 x 6 (152 x 152)
Maximum duct size: see table.
Available in 3" (76) increments only.

IMPERIAL MODULES				METRIC MODULES	
Imperial Units (in.)		Metric Units (mm)		Metric Units (mm)	
CM	Maximum Duct Size	CM	Maximum Duct Size	CM	Maximum Duct Size
12 x 12	9 x 9	305 x 305	229 x 229	300 x 300	152 x 152
24 x 12	21 x 9	610 x 305	533 x 229	600 x 300	457 x 152
24 x 24	21 x 21	610 x 610	533 x 533	600 x 600	457 x 457

CORE STYLE SELECTION

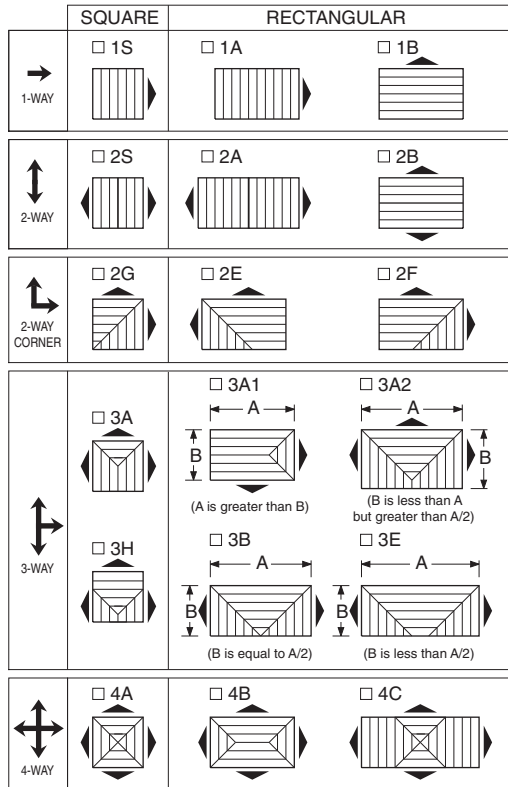

Patterns are shown in plan view (looking down into inlet).

Spline Type Diffuser for one-directional exposed T-bar lay-in grid or for concealed T-bar grid (splines on two opposite sides - steel lift brackets on other two sides).

DESCRIPTION:

1. Material: Corrosion-resistant steel.
2. Model 6500IV is a high capacity ceiling diffuser available in 1, 2, 3 or 4-way blow patterns to provide a tight horizontal airflow pattern from maximum to minimum airflow. The induction vanes consist of a set of 45° angled diffusion vanes spaced 1 1/2" (38) apart on the back of each diffuser louver. Vane sets on adjacent parallel louvers run in opposite directions and cause primary air to emerge from each louver at alternating angles. The resulting turbulent discharge air jets produce high induction rates and rapid temperature equalization, making the diffuser eminently suitable for VAV applications as the possibility of downdrafts (dumping) are eliminated.
3. Spring-loaded removable core.
4. Standard finish is AW Appliance White.

OPTIONS:

SQUARE AND RECTANGULAR NECK

- Steel opposed blade damper. Model 6500IV-O.
- ONA Offset neck adaptor. Fits outside duct (if a damper is required, order separately for remote mount. See Model OBDD).

ROUND NECK

- SR Square to round transition collar
- SR-O Square to round transition collar for use over O.B.D.
- 4275 Radial Opposed Blade Damper (round)
- 4250 Radial Sliding Blade Damper (round)
- 4675 Butterfly Damper (round)

EXTERNAL INSULATION

- EX External Foil-Back Insulation, installed -R-4.2.
- MIB Molded Insulation Blanket, -R-6.0.

OPTIONAL FINISH:

- SP Special. Specify _____.

SCHEDULE TYPE:	Dimensions are in inches (mm).			
PROJECT:				
ENGINEER:	DATE	B SERIES	SUPERSEDES	DRAWING NO.
CONTRACTOR:	2 - 8 - 18	6500	11 - 24 - 16	6500IV-4



**PATTERN CEILING DIFFUSERS
WITH IV INDUCTION VANES**
STEEL • SQUARE, RECTANGULAR OR ROUND NECK
MODELS: 6500IV AND 6500IV-O TYPE F

OFFSET NECK OPTION

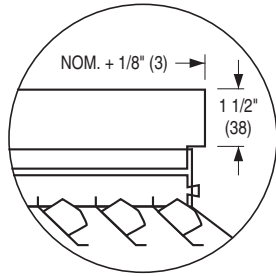

FOR FINELINE® TYPE CEILING SYSTEMS

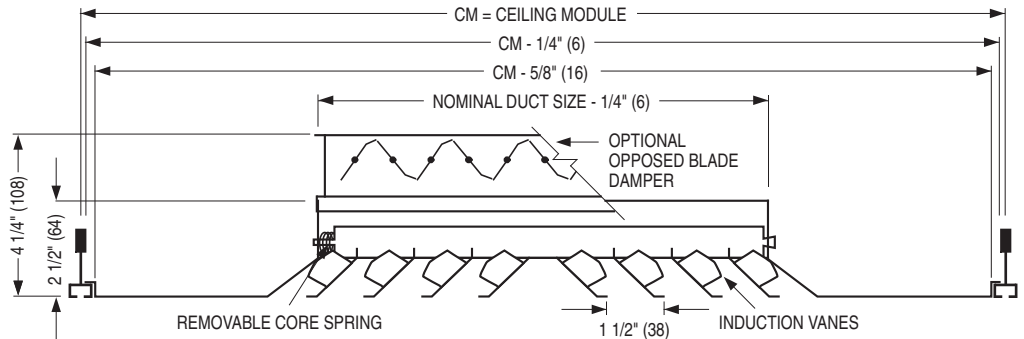

TYPE F • FINELINE® T-BAR

If the ceiling module is not 3" (76) larger than the neck size of the diffuser in both dimensions, a module sized extended panel will be added.
Minimum duct size: 6 x 6 (152 x 152)
Maximum duct size: see table.
Available in 3" (76) increments only.

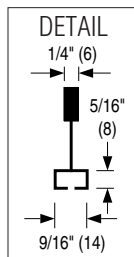

IMPERIAL MODULES				METRIC MODULES	
Imperial Units (in.)		Metric Units (mm)		Metric Units (mm)	
CM	Maximum Duct Size	CM	Maximum Duct Size	CM	Maximum Duct Size
12 x 12	6 x 6	305 x 305	152 x 152	300 x 300	152 x 152
24 x 12	18 x 6	610 x 305	457 x 152	600 x 300	457 x 152
24 x 24	18 x 18	610 x 610	457 x 457	600 x 600	457 x 457

Fineline® is a registered trademark of USG Interiors Inc.

CORE STYLE SELECTION

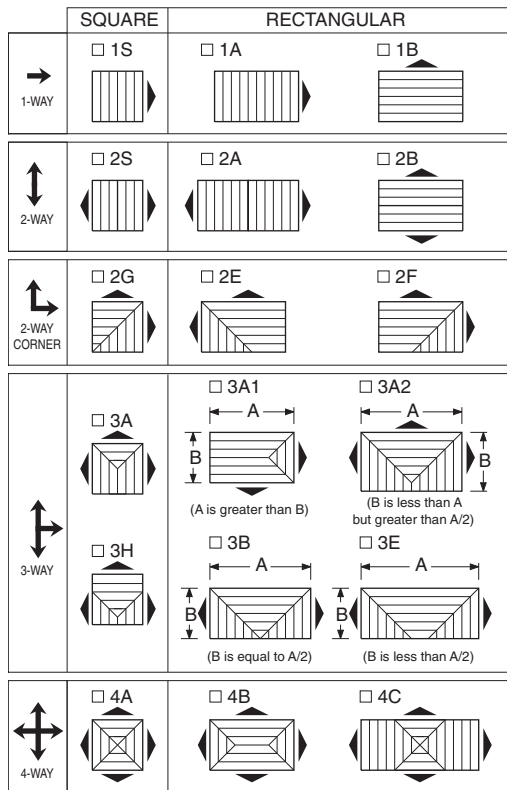

Patterns are shown in plan view (looking down into inlet).

DESCRIPTION:

- Material: Corrosion-resistant steel.
- Model 6500IV is a high capacity ceiling diffuser available in 1, 2, 3 or 4-way blow patterns to provide a tight horizontal airflow pattern from maximum to minimum airflow. The induction vanes consist of a set of 45° angled diffusion vanes spaced 1 1/2" (38) apart on the back of each diffuser louver. Vane sets on adjacent parallel louvers run in opposite directions and cause primary air to emerge from each louver at alternating angles. The resulting turbulent discharge air jets produce high induction rates and rapid temperature equalization, making the diffuser eminently suitable for VAV applications as the possibility of downdrafts (dumping) are eliminated.
- Spring-loaded removable core.
- Standard finish is AW Appliance White.

OPTIONS:

SQUARE AND RECTANGULAR NECK

- Steel opposed blade damper. Model 6500IV-O.
- ONA Offset neck adaptor. Fits outside duct (if a damper is required, order separately for remote mount. See Model OBDD).

ROUND NECK

- SR Square to round transition collar
- SR-O Square to round transition collar for use over O.B.D.
- 4275 Radial Opposed Blade Damper (round)
- 4250 Radial Sliding Blade Damper (round)
- 4675 Butterfly Damper (round)

EXTERNAL INSULATION

- EX External Foil-Back Insulation, installed -R-4.2.
- MIB Molded Insulation Blanket, -R-6.0. ('MIB' is available for Frame Types L, TL and F with a 24 x 24 CM only, 15 x 15 max. neck size and a 'SR' Square-to-round transition collar).

OPTIONAL FINISH:

- SP Special. Specify _____.

SCHEDULE TYPE:

PROJECT:

ENGINEER:

CONTRACTOR:

Dimensions are in inches (mm).

DATE

B SERIES

SUPERSEDES

DRAWING NO.

2 - 8 - 18

6500

1 - 16 - 17

6500IV-5



**PATTERN CEILING DIFFUSERS WITH IV
INDUCTION VANES**
STEEL • SQUARE, RECT. OR ROUND NECK
MODELS: 6500IV AND 6500IV-O TYPE TL

OFFSET NECK OPTION

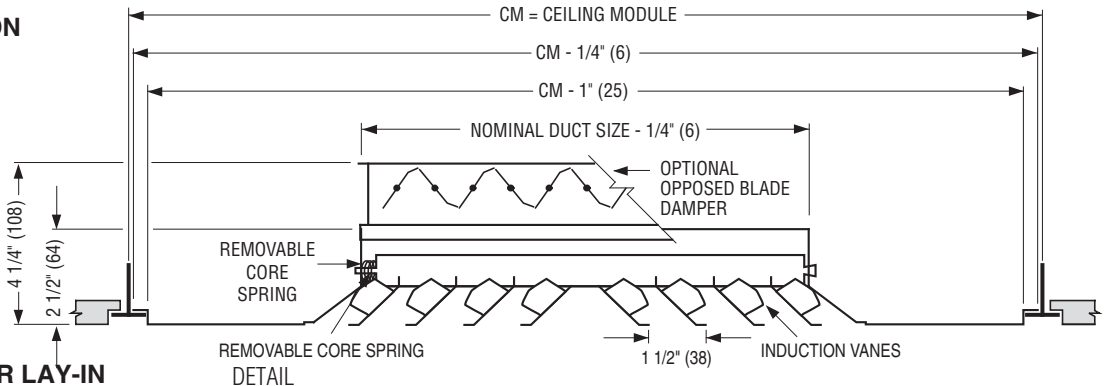
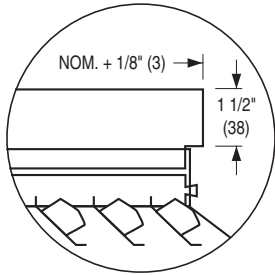

TYPE TL • TEGULAR LAY-IN

The diffuser is supplied in a module sized extended panel which drops the diffuser face below the T-bar so that it is flush with the tegular ceiling panels.

Minimum duct size: 6 x 6 (152 x 152)
Maximum duct size: see table.
Available in 3" (76) increments only.

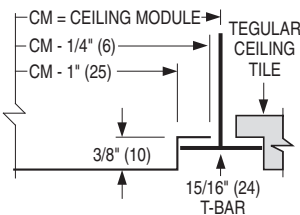

IMPERIAL MODULES				METRIC MODULES	
Imperial Units (in.)		Metric Units (mm)		Metric Units (mm)	
CM	Maximum Duct Size	CM	Maximum Duct Size	CM	Maximum Duct Size
12 x 12	6 x 6	305 x 305	152 x 152	300 x 300	152 x 152
24 x 12	18 x 6	610 x 305	457 x 152	600 x 300	457 x 152
24 x 24	18 x 18	610 x 610	457 x 457	600 x 600	457 x 457

CORE STYLE SELECTION

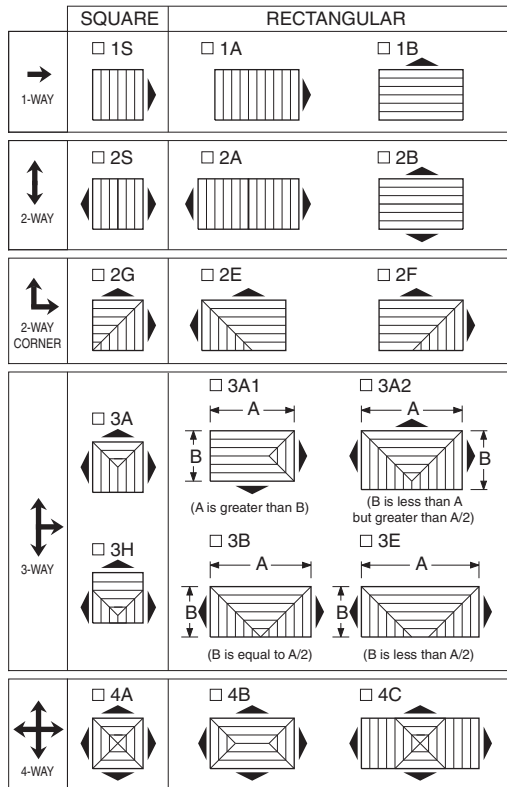

Patterns are shown in plan view (looking down into inlet).

DESCRIPTION:

1. Material: Corrosion-resistant steel.
2. Model 6500IV is a high capacity ceiling diffuser available in 1, 2, 3 or 4-way blow patterns to provide a tight horizontal airflow pattern from maximum to minimum airflow. The induction vanes consist of a set of 45° angled diffusion vanes spaced 1 1/2" (38) apart on the back of each diffuser louver. Vane sets on adjacent parallel louvers run in opposite directions and cause primary air to emerge from each louver at alternating angles. The resulting turbulent discharge air jets produce high induction rates and rapid temperature equalization, making the diffuser eminently suitable for VAV applications as the possibility of downdrafts (dumping) are eliminated.
3. Spring-loaded removable core.
4. Standard finish is AW Appliance White.

OPTIONS:

- PLA Aluminum Extended Panel.
- SQUARE AND RECTANGULAR NECK
- Steel opposed blade damper. Model 6500IV-O.
- ONA Offset neck adaptor. Fits outside duct (if a damper is required, order separately for remote mount. See Model OBDD).

ROUND NECK

- SR Square to round transition collar
- SR-O Square to round transition collar for use over O.B.D.
- 4275 Radial Opposed Blade Damper (round)
- 4250 Radial Sliding Blade Damper (round)
- 4675 Butterfly Damper (round)

EXTERNAL INSULATION

- EX External Foil-Back Insulation, installed -R-4.2.
- MIB Molded Insulation Blanket, -R-6.0. ('MIB' is available for Frame Types L, TL and F with a 24 x 24 CM only, 15 x 15 max. neck size and a 'SR' Square-to-round transition collar).

OPTIONAL FINISH:

- SP Special. Specify _____.

SCHEDULE TYPE:	Dimensions are in inches (mm).			
PROJECT:				
ENGINEER:	DATE	B SERIES	SUPERSEDES	DRAWING NO.
CONTRACTOR:	1 - 16 - 17	6500	2 - 12 - 16	6500IV-6



**PATTERN CEILING DIFFUSERS
WITH IV INDUCTION VANES**
STEEL • SQUARE, RECTANGULAR OR ROUND NECK
MODELS: 6500IV AND 6500IV-O TYPE M

OFFSET NECK OPTION

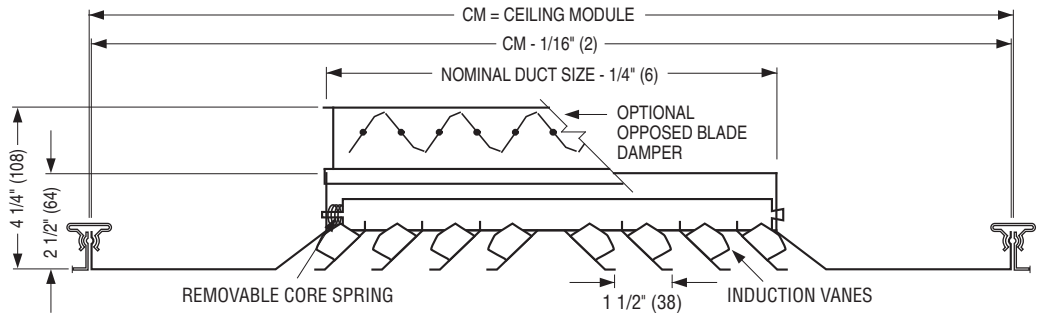
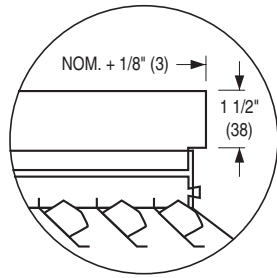

TYPE M • METAL PAN (SNAP-IN)

If the ceiling module is not 3" (76) larger than the neck size of the diffuser in both dimensions, a module sized extended panel will be added.

Minimum duct size: 6 x 6 (152 x 152)

Maximum duct size: see table.

Available in 3" (76) increments only.

IMPERIAL MODULES				METRIC MODULES	
Imperial Units (in.)		Metric Units (mm)		Metric Units (mm)	
CM	Maximum Duct Size	CM	Maximum Duct Size	CM	Maximum Duct Size
12 x 12	9 x 9	305 x 305	229 x 229	300 x 300	152 x 152
24 x 12	21 x 9	610 x 305	533 x 229	600 x 300	457 x 152
24 x 24	21 x 21	610 x 610	533 x 533	600 x 600	457 x 457

CORE STYLE SELECTION

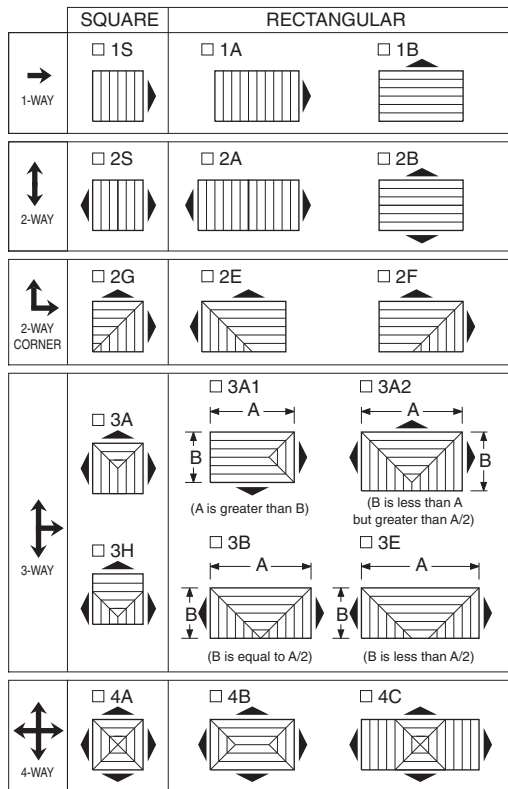

Patterns are shown in plan view (looking down into inlet).

DESCRIPTION:

1. Material: Corrosion-resistant steel.
2. Model 6500IV is a high capacity ceiling diffuser available in 1, 2, 3 or 4-way blow patterns to provide a tight horizontal airflow pattern from maximum to minimum airflow. The induction vanes consist of a set of 45° angled diffusion vanes spaced 1 1/2" (38) apart on the back of each diffuser louver. Vane sets on adjacent parallel louvers run in opposite directions and cause primary air to emerge from each louver at alternating angles. The resulting turbulent discharge air jets produce high induction rates and rapid temperature equalization, making the diffuser eminently suitable for VAV applications as the possibility of downdrafts (dumping) are eliminated.
3. Spring-loaded removable core.
4. Standard finish is AW Appliance White.

OPTIONS:

SQUARE AND RECTANGULAR NECK

- Steel opposed blade damper. Model 6500IV-O.
- ONA Offset neck adaptor. Fits outside duct (if a damper is required, order separately for remote mount. See Model OBDD).

ROUND NECK

- SR Square to round transition collar
- SR-O Square to round transition collar for use over O.B.D.
- 4275 Radial Opposed Blade Damper (round)
- 4250 Radial Sliding Blade Damper (round)
- 4675 Butterfly Damper (round)

EXTERNAL INSULATION

- EX External Foil-Back Insulation, installed -R-4.2.
- MIB Molded Insulation Blanket, -R-6.0.

OPTIONAL FINISH:

- SP Special. Specify _____ .

SCHEDULE TYPE:	Dimensions are in inches (mm).			
PROJECT:				
ENGINEER:	DATE	B SERIES	SUPERSEDES	DRAWING NO.
CONTRACTOR:	2 - 8 - 18	6500	11 - 24 - 16	6500IV-7



PATTERN CEILING DIFFUSERS
ADJUSTABLE VANES • STEEL
• SQUARE OR ROUND NECK
MODELS: 6550 AND 6550-O TYPES S & B

TYPE S • SURFACE MOUNT • FLAT FRAME

Minimum duct size: 6 x 6 (152 x 152)
 Maximum duct size: 24 x 24 (610 x 610)
 Available in 3" (76) increments only.

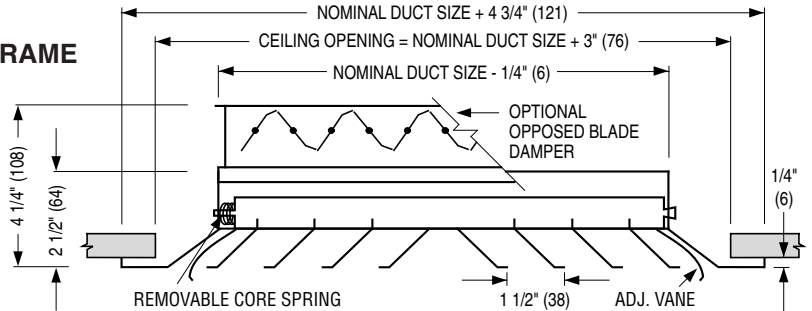

TYPE B • BEVELED DROP FACE
• SURFACE MOUNT

Minimum duct size: 6 x 6 (152 x 152)
 Maximum duct size: 24 x 24 (610 x 610)
 Available in 3" (76) increments only.

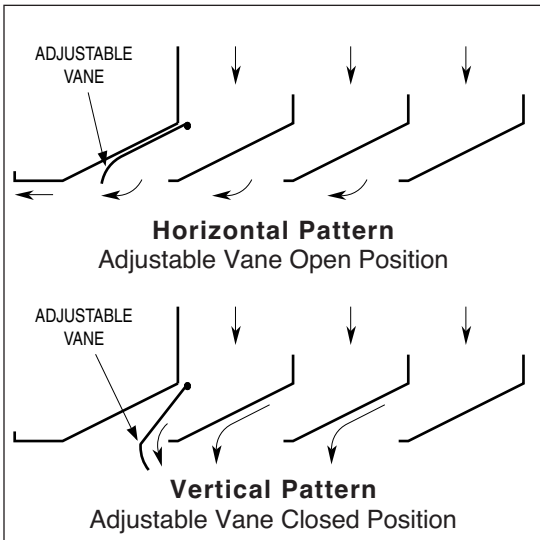
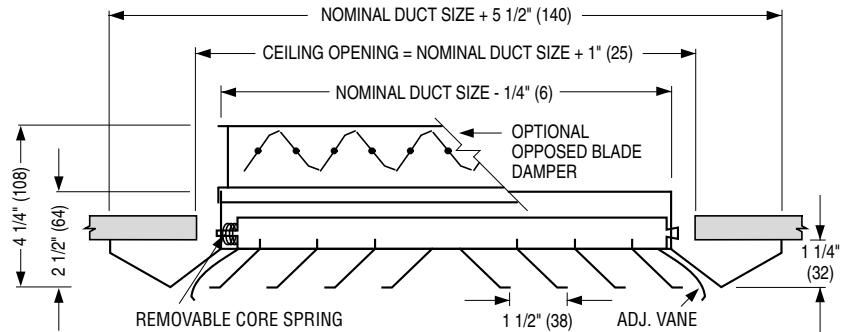

DESCRIPTION:

1. Material: Corrosion-resistant steel.
2. Model 6550 is a high capacity ceiling diffuser available with a square 4-way blow pattern as standard (optional core styles are available). The unit is supplied with independent movable vanes on all four sides to provide a horizontal to vertical throw adjustable discharge. In the horizontal setting, the diffuser provides a tight horizontal airflow pattern from maximum to minimum airflow. Ideal for VAV applications.
3. Spring-loaded removable core.
4. Standard finish is AW Appliance White.

OPTIONS:

SQUARE AND RECTANGULAR NECK

Steel opposed blade damper. Model 6550-O.

ROUND NECK

- SR Square to round transition collar
- SR-O Square to round transition collar for use over O.B.D.
- 4275 Radial Opposed Blade Damper (round)
- 4250 Radial Sliding Blade Damper (round)
- 4675 Butterfly Damper (round)

EXTERNAL INSULATION

EX External Foil-Back Insulation, installed -R-4.2.

OPTIONAL FINISH:

SP Special. Specify _____.

SCHEDULE TYPE:		Dimensions are in inches (mm).			
PROJECT:					
ENGINEER:	DATE	B SERIES	SUPERSEDES	DRAWING NO.	
CONTRACTOR:	11 - 24 - 16	6550	5 - 11 - 15	6550-1	



PATTERN CEILING DIFFUSERS
ADJUSTABLE VANES • STEEL
• SQUARE OR ROUND NECK
MODELS: 6550 AND 6550-O TYPE D

TYPE D DEEP DROP FACE

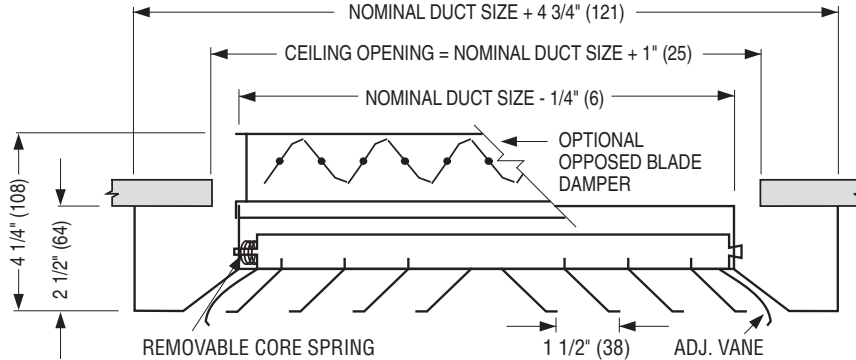

Minimum duct size: 6 x 6 (152 x 152).
 Maximum duct size: 36 x 36 (914 x 914) or 36 x 24 (914 x 610)
 with O.B.D.
 Available in 3" (76) increments only.

CORE STYLE SELECTION

	SQUARE	RECTANGULAR	
→ 1-WAY	<input type="checkbox"/> 1S	<input type="checkbox"/> 1A	<input type="checkbox"/> 1B
↕ 2-WAY	<input type="checkbox"/> 2S	<input type="checkbox"/> 2A	<input type="checkbox"/> 2B
↙↘ 2-WAY CORNER	<input type="checkbox"/> 2G	<input type="checkbox"/> 2E	<input type="checkbox"/> 2F
↕↔ 3-WAY	<input type="checkbox"/> 3A	<input type="checkbox"/> 3A1 A > B	<input type="checkbox"/> 3A2 B < A but > A/2
		<input type="checkbox"/> 3B B = A/2	<input type="checkbox"/> 3E B < A/2
↕↔↕ 4-WAY	<input type="checkbox"/> 4A	<input type="checkbox"/> 4B	<input type="checkbox"/> 4C

Patterns are shown in plan view (looking down into inlet).

DESCRIPTION:

1. Material: Corrosion-resistant steel.
2. Model 6550 is a high capacity ceiling diffuser available with a square 4-way blow pattern as standard (optional core styles are available). The unit is supplied with independent movable vanes on all four sides to provide a horizontal to vertical throw adjustable discharge. In the horizontal setting, the diffuser provides a tight horizontal airflow pattern from maximum to minimum airflow. Ideal for VAV applications.
3. Spring-loaded removable core.
4. Standard finish is AW Appliance White.

OPTIONS:

SQUARE AND RECTANGULAR NECK

Steel opposed blade damper. Model 6550-O.

ROUND NECK

- SR Square to round transition collar
- SR-O Square to round transition collar for use over O.B.D.
- 4275 Radial Opposed Blade Damper (round)
- 4250 Radial Sliding Blade Damper (round)
- 4675 Butterfly Damper (round)

EXTERNAL INSULATION

EX External Foil-Back Insulation, installed -R-4.2.

OPTIONAL FINISH:

SP Special. Specify _____ .

SCHEDULE TYPE:		Dimensions are in inches (mm).			
PROJECT:					
ENGINEER:	DATE	B SERIES	SUPERSEDES	DRAWING NO.	
CONTRACTOR:	11 - 24 - 16	6550	5 - 11 - 15	6550-2	



PATTERN CEILING DIFFUSERS
ADJUSTABLE VANES • STEEL
• SQUARE OR ROUND NECK
MODELS: 6550 AND 6550-O TYPE L

TYPE L LAY-IN T-BAR

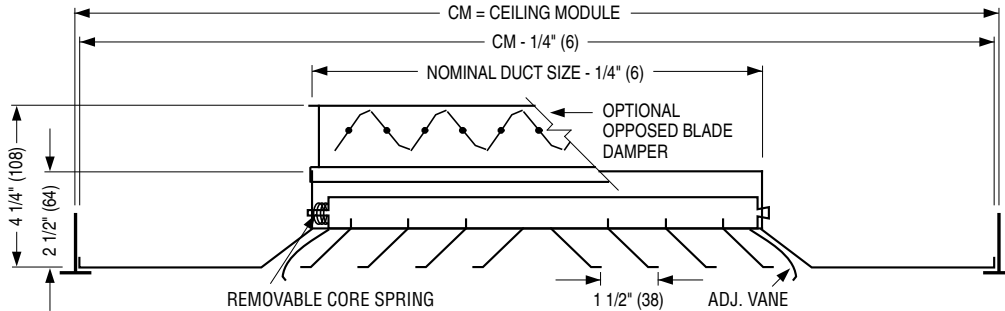

If the ceiling module is not 3" (76) or 6" (152) larger than the neck size of the diffuser in both dimensions, a module sized extended panel will be added.
 Minimum duct size: 6 x 6 (152 x 152).
 Maximum duct size: see table.
 Available in 3" (76) increments only.

IMPERIAL MODULES				METRIC MODULES	
Imperial Units (in.)		Metric Units (mm)		Metric Units (mm)	
CM	Maximum Duct Size	CM	Maximum Duct Size	CM	Maximum Duct Size
12 x 12	6 x 6	305 x 305	152 x 152	300 x 300	152 x 152
20 x 20	15 x 15	508 x 508	381 x 381	500 x 500	381 x 381
24 x 12	18 x 6	610 x 305	457 x 152	600 x 300	457 x 152
24 x 24	18 x 18	610 x 610	457 x 457	600 x 600	457 x 457
48 x 24	18 x 18	1219 x 610	457 x 457	1200 x 600	457 x 457

DESCRIPTION:

1. Material: Corrosion-resistant steel.
2. Model 6550 is a high capacity ceiling diffuser available with a square 4-way blow pattern as standard (optional core styles are available). The unit is supplied with independent movable vanes on all four sides to provide a horizontal to vertical throw adjustable discharge. In the horizontal setting, the diffuser provides a tight horizontal airflow pattern from maximum to minimum airflow. Ideal for VAV applications.
3. Spring-loaded removable core.
4. Standard finish is AW Appliance White.

OPTIONS:

SQUARE AND RECTANGULAR NECK

- Steel opposed blade damper. Model 6550-O.

ROUND NECK

- SR Square to round transition collar
- SR-O Square to round transition collar for use over O.B.D.
- 4275 Radial Opposed Blade Damper (round)
- 4250 Radial Sliding Blade Damper (round)
- 4675 Butterfly Damper (round)

EXTERNAL INSULATION

- EX External Foil-Back Insulation, installed -R-4.2.
- MIB Molded Insulation Blanket, -R-6.0. ('MIB' is available for Frame Types L, TL and F with a 24 x 24 CM only, 15 x 15 max. neck size and a 'SR' square-to-round transition collar).

OPTIONAL FINISH:

- SP Special. Specify _____ .

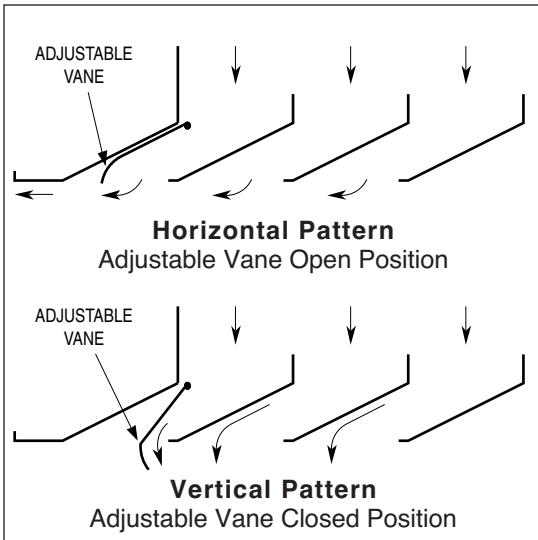

SCHEDULE TYPE:	Dimensions are in inches (mm).			
PROJECT:				
ENGINEER:	DATE	B SERIES	SUPERSEDES	DRAWING NO.
CONTRACTOR:	2 - 8 - 18	6550	1 - 16 - 17	6550-3



PATTERN CEILING DIFFUSERS
ADJUSTABLE VANES • STEEL
• SQUARE OR ROUND NECK
MODELS: 6550 AND 6550-O TYPE SP

TYPE SP SPLINE

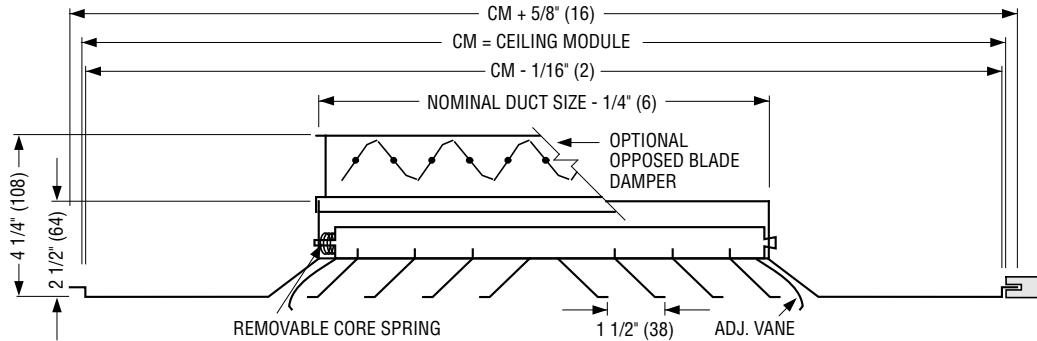

The diffuser is supplied in a module sized extended panel.
 Minimum duct size: 6 x 6 (152 x 152).
 Maximum duct size: see table.
 Available in 3" (76) increments only.

IMPERIAL MODULES				METRIC MODULES	
Imperial Units (in.)		Metric Units (mm)		Metric Units (mm)	
CM	Maximum Duct Size	CM	Maximum Duct Size	CM	Maximum Duct Size
12 x 12	6 x 6	305 x 305	152 x 152	300 x 300	152 x 152
24 x 12	18 x 6	610 x 305	457 x 152	600 x 300	457 x 152
24 x 24	18 x 18	610 x 610	457 x 457	600 x 600	457 x 457

Spline Type Diffuser for one-directional exposed T-bar lay-in grid or for concealed T-bar grid (splines on two opposite sides - steel lift brackets on other two sides).

DESCRIPTION:

1. Material: Corrosion-resistant steel.
2. Model 6550 is a high capacity ceiling diffuser available with a square 4-way blow pattern as standard (optional core styles are available). The unit is supplied with independent movable vanes on all four sides to provide a horizontal to vertical throw adjustable discharge. In the horizontal setting, the diffuser provides a tight horizontal airflow pattern from maximum to minimum airflow. Ideal for VAV applications.
3. Spring-loaded removable core.
4. Standard finish is AW Appliance White.

OPTIONS:

SQUARE AND RECTANGULAR NECK

Steel opposed blade damper. Model 6550-O.

ROUND NECK

- SR Square to round transition collar
- SR-O Square to round transition collar for use over O.B.D.
- 4275 Radial Opposed Blade Damper (round)
- 4250 Radial Sliding Blade Damper (round)
- 4675 Butterfly Damper (round)

EXTERNAL INSULATION

EX External Foil-Back Insulation, installed -R-4.2.

OPTIONAL FINISH:

SP Special. Specify _____ .

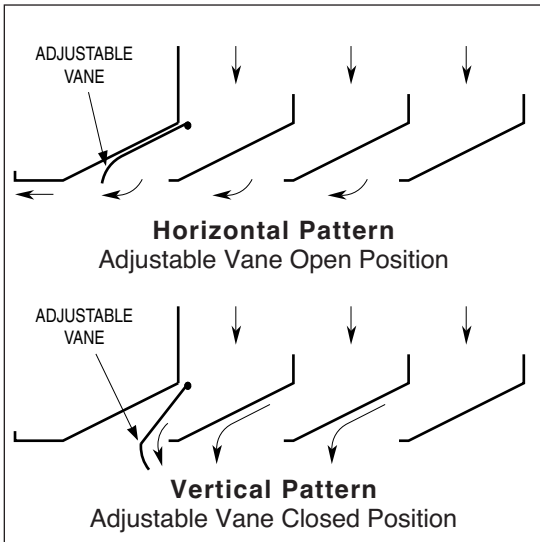

SCHEDULE TYPE:	
PROJECT:	
ENGINEER:	
CONTRACTOR:	

Dimensions are in inches (mm).

DATE	B SERIES	SUPERSEDES	DRAWING NO.
11 - 24 - 16	6550	5 - 11 - 15	6550-4



PATTERN CEILING DIFFUSERS
ADJUSTABLE VANES • STEEL
• SQUARE OR ROUND NECK
MODELS: 6550 AND 6550-O TYPE F

TYPE F FINELINE® T-BAR FOR FINELINE® TYPE CEILING SYSTEMS

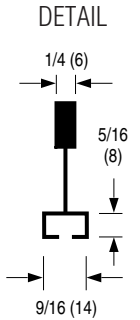
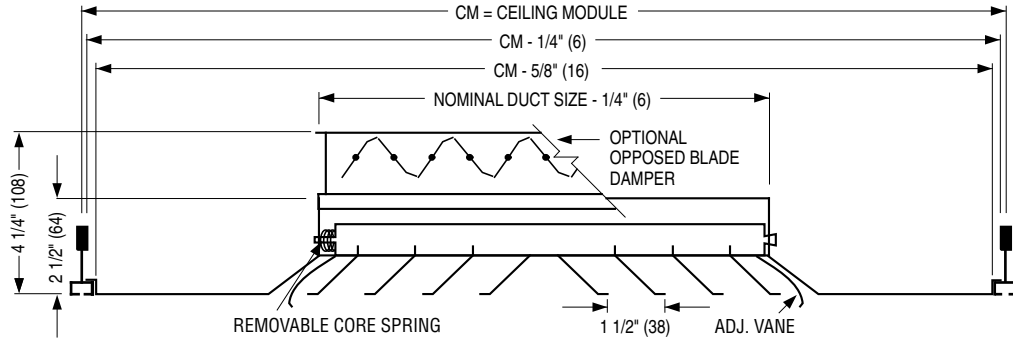

The diffuser is supplied in a module sized extended panel.
 Minimum duct size: 6 x 6 (152 x 152).
 Maximum duct size: see table.
 Available in 3" (76) increments only.

IMPERIAL MODULES				METRIC MODULES	
Imperial Units (in.)		Metric Units (mm)		Metric Units (mm)	
CM	Maximum Duct Size	CM	Maximum Duct Size	CM	Maximum Duct Size
12 x 12	6 x 6	305 x 305	152 x 152	300 x 300	152 x 152
24 x 12	18 x 6	610 x 305	457 x 152	600 x 300	457 x 152
24 x 24	18 x 18	610 x 610	457 x 457	600 x 600	457 x 457

DESCRIPTION:

1. Material: Corrosion-resistant steel.
2. Model 6550 is a high capacity ceiling diffuser available with a square 4-way blow pattern as standard (optional core styles are available). The unit is supplied with independent movable vanes on all four sides to provide a horizontal to vertical throw adjustable discharge. In the horizontal setting, the diffuser provides a tight horizontal airflow pattern from maximum to minimum airflow. Ideal for VAV applications.
3. Spring-loaded removable core.
4. Standard finish is AW Appliance White.

OPTIONS:

SQUARE AND RECTANGULAR NECK

- Steel opposed blade damper. Model 6550-O.

ROUND NECK

- SR Square to round transition collar
- SR-O Square to round transition collar for use over O.B.D.
- 4275 Radial Opposed Blade Damper (round)
- 4250 Radial Sliding Blade Damper (round)
- 4675 Butterfly Damper (round)

EXTERNAL INSULATION

- EX External Foil-Back Insulation, installed - R-4.2.
- MIB Molded Insulation Blanket, -R-6.0. ('MIB' is available for Frame Types L, TL and F with a 24 x 24 CM only, 15 x 15 max. neck size and a 'SR' square-to-round transition collar).

OPTIONAL FINISH:

- SP Special. Specify _____ .

Fineline® is a registered trademark of USG Interiors Inc..

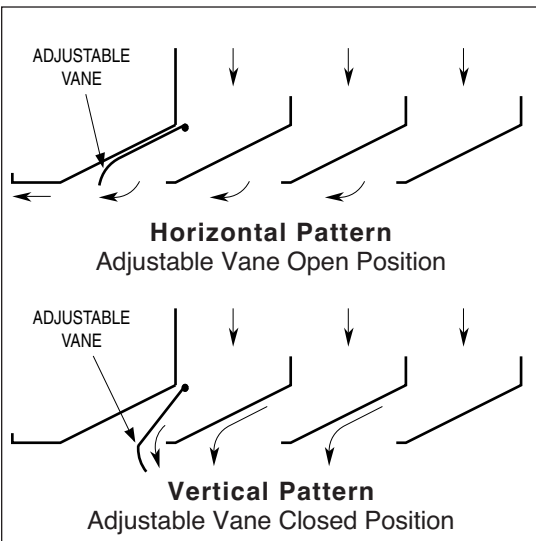

SCHEDULE TYPE:	Dimensions are in inches (mm).			
PROJECT:				
ENGINEER:	DATE	B SERIES	SUPERSEDES	DRAWING NO.
CONTRACTOR:	1 - 16 - 17	6550	5 - 11 - 15	6550-5



PATTERN CEILING DIFFUSERS
ADJUSTABLE VANES • STEEL
• SQUARE OR ROUND NECK
MODELS: 6550 AND 6550-O TYPE TL

TYPE TL
REGULAR LAY-IN

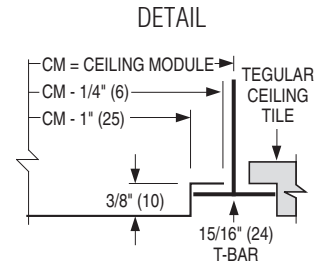
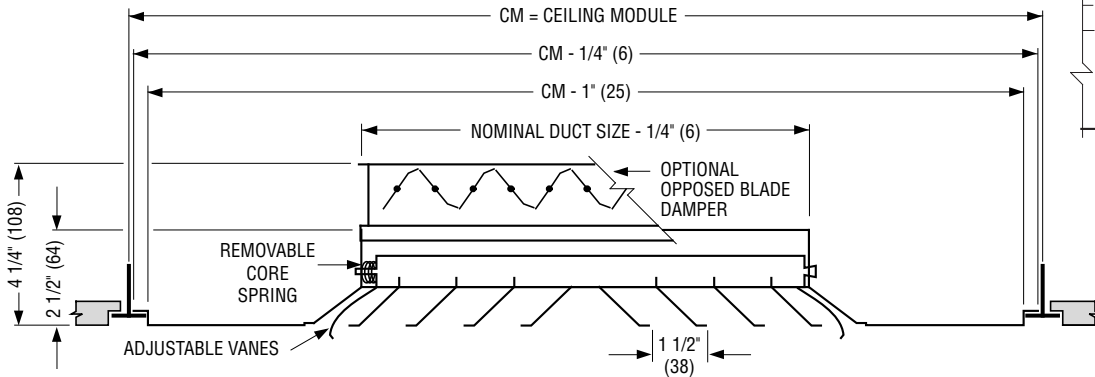

The diffuser is supplied in a module sized extended panel which drops the diffuser face below the T-bar so that it is flush with the tegular ceiling panels.

Minimum duct size: 6 x 6 (152 x 152).

Maximum duct size: see table.

Available in 3" (76) increments only.

IMPERIAL MODULES				METRIC MODULES	
Imperial Units (in.)		Metric Units (mm)		Metric Units (mm)	
CM	Maximum Duct Size	CM	Maximum Duct Size	CM	Maximum Duct Size
12 x 12	6 x 6	305 x 305	152 x 152	300 x 300	152 x 152
24 x 12	18 x 6	610 x 305	457 x 152	600 x 300	457 x 152
24 x 24	18 x 18	610 x 610	457 x 457	600 x 600	457 x 457

DESCRIPTION:

1. Material: Corrosion-resistant steel.
2. Model 6550 is a high capacity ceiling diffuser available with a square 4-way blow pattern (core style 4A) as standard (optional core styles are available). The unit is supplied with independent movable vanes on all four sides to provide a horizontal to vertical throw adjustable discharge. In the horizontal setting, the diffuser provides a tight horizontal airflow pattern from maximum to minimum airflow. Ideal for VAV applications.

The diffuser is supplied in a module sized extended panel which drops the diffuser face below the T-bar so that it is flush with the tegular ceiling panels.
3. Spring-loaded removable core.
4. Standard finish is AW Appliance White.

OPTIONS:

SQUARE AND RECTANGULAR NECK

- Steel opposed blade damper. Model 6550-O.

ROUND NECK

- SR Square to round transition collar
- SR-O Square to round transition collar for use over O.B.D.
- 4275 Radial Opposed Blade Damper (round)
- 4250 Radial Sliding Blade Damper (round)
- 4675 Butterfly Damper (round)

EXTERNAL INSULATION

- EX External Foil-Back Insulation, installed -R-4.2.
- MIB Molded Insulation Blanket, -R-6.0. ('MIB' is available for Frame Types L, TL and F with a 24 x 24 CM only, 15 x 15 max. neck size and a 'SR' square-to-round transition collar).

OPTIONAL FINISH:

- SP Special. Specify _____.

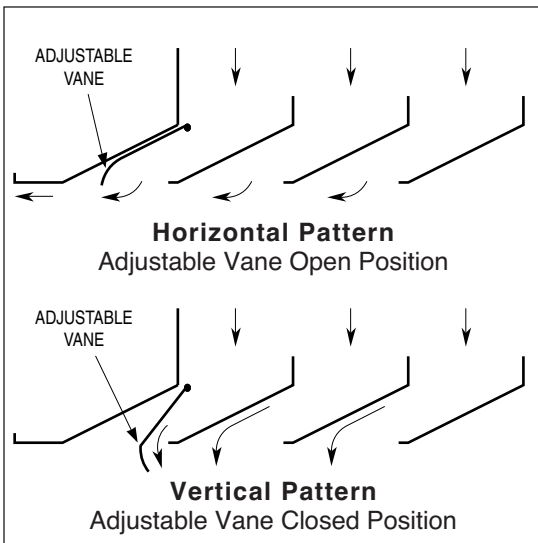

SCHEDULE TYPE:	
PROJECT:	
ENGINEER:	
CONTRACTOR:	

Dimensions are in inches (mm).

DATE	B SERIES	SUPERSEDES	DRAWING NO.
1 - 16 - 17	6550	5 - 11 - 15	6550-6



PATTERN CEILING DIFFUSERS
ADJUSTABLE VANES • STEEL
• SQUARE OR ROUND NECK
MODELS: 6550 AND 6550-O TYPE M

TYPE M METAL PAN (SNAP-IN)

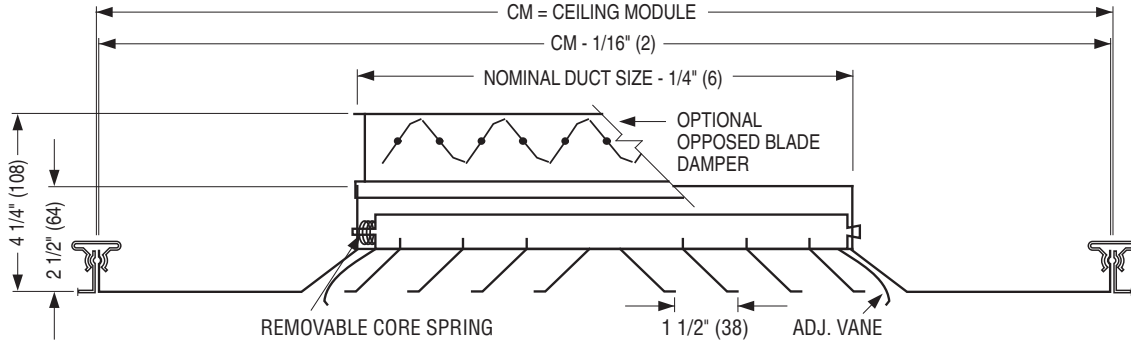

If the ceiling module is not 3" (76) larger than the neck size of the diffuser in both dimensions, a module sized extended panel will be added.

Minimum duct size: 6 x 6 (152 x 152).

Maximum duct size: see table.

Available in 3" (76) increments only.

IMPERIAL MODULES				METRIC MODULES	
Imperial Units (in.)		Metric Units (mm)		Metric Units (mm)	
CM	Maximum Duct Size	CM	Maximum Duct Size	CM	Maximum Duct Size
12 x 12	6 x 6	305 x 305	152 x 152	300 x 300	152 x 152
24 x 12	18 x 6	610 x 305	457 x 152	600 x 300	457 x 152
24 x 24	18 x 18	610 x 610	457 x 457	600 x 600	457 x 457

CORE STYLE SELECTION

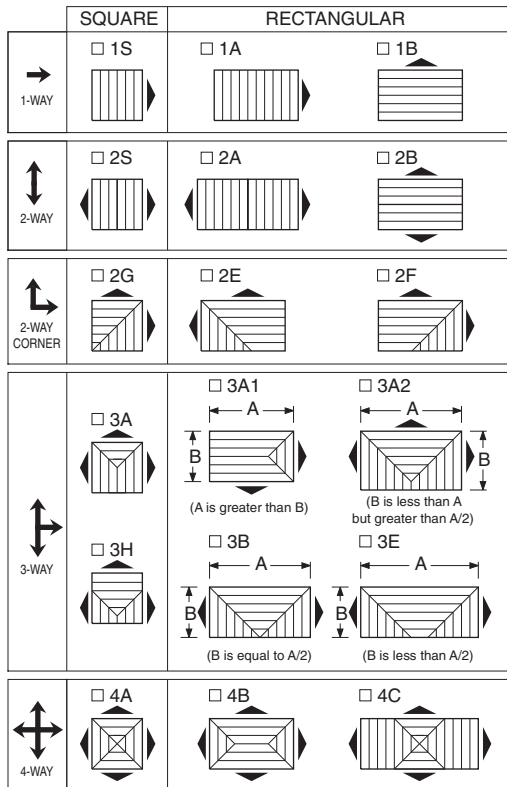

Patterns are shown in plan view (looking down into inlet).

DESCRIPTION:

1. Material: Corrosion-resistant steel.
2. Model 6550 is a high capacity ceiling diffuser available with a square 4-way blow pattern as standard (optional core styles are available). The unit is supplied with independent movable vanes on all four sides to provide a horizontal to vertical throw adjustable discharge. In the horizontal setting, the diffuser provides a tight horizontal airflow pattern from maximum to minimum airflow. Ideal for VAV applications.
3. Spring-loaded removable core.
4. Standard finish is AW Appliance White.

OPTIONS:

SQUARE AND RECTANGULAR NECK

Steel opposed blade damper. Model 6550-O.

ROUND NECK

- SR Square to round transition collar
- SR-O Square to round transition collar for use over O.B.D.
- 4275 Radial Opposed Blade Damper (round)
- 4250 Radial Sliding Blade Damper (round)
- 4675 Butterfly Damper (round)

EXTERNAL INSULATION

EX External Foil-Back Insulation, installed -R-4.2.

OPTIONAL FINISH:

SP Special. Specify _____.

SCHEDULE TYPE:	Dimensions are in inches (mm).			
PROJECT:				
ENGINEER:	DATE	B SERIES	SUPERSEDES	DRAWING NO.
CONTRACTOR:	2 - 8 - 18	6550	11 - 24 - 16	6550-7

OPPOSED BLADE DAMPER

Corrosion-resistant steel. 22 ga. roll-formed frame and blade.

- Model OBD Type SL Screwdriver slot operator
- Model OBD Type L Lever operator

Type SL requires diffuser face removal for access.
 Type L can be adjusted without removing core.

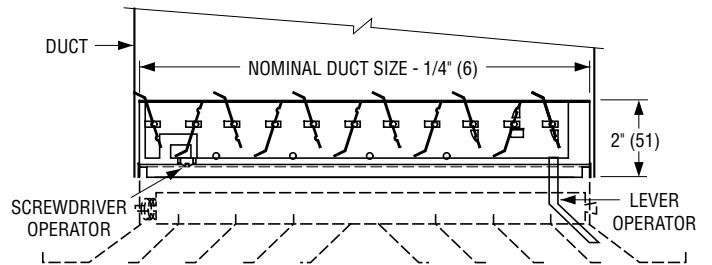
SQUARE-TO-ROUND TRANSITION COLLAR

- Model SR (for use with optional round neck damper)
- Model SR-O (for use over opposed blade damper)

CONSTRUCTION:
 22 ga. corrosion-resistant steel.

SQUARE NECK SIZE (INCHES)	ROUND NECK SIZE (INCHES)
6 x 6	4, 5, 6
8 x 8	4, 5, 6, 7, 8
9 x 9	6, 7, 8, 9
10 x 10	6, 7, 8, 9, 10
12 x 12	6, 8, 9, 10, 12
14 x 14	6, 8, 9, 10, 12, 14
15 x 15	6, 8, 10, 12, 14, 15
16 x 16	6, 8, 10, 12, 14, 15, 16
18 x 18	6, 8, 10, 12, 14, 15, 16, 18
20 x 20	6, 8, 10, 12, 14, 15, 16, 18, 20
21 x 21	6, 8, 10, 12, 14, 15, 16, 18, 20
22 x 22	6, 8, 10, 12, 14, 16, 18, 20
24 x 24	6, 8, 10, 12, 14, 15, 16, 18, 20, 22, 24

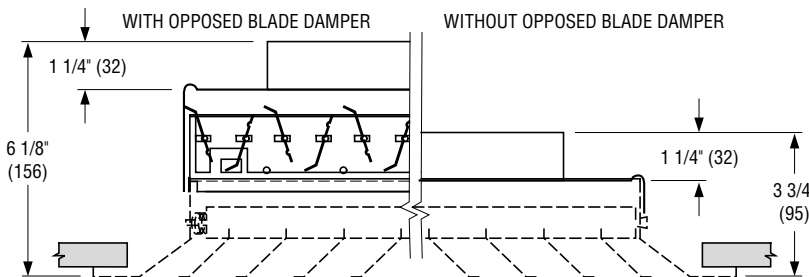

ROUND NECK DAMPERS

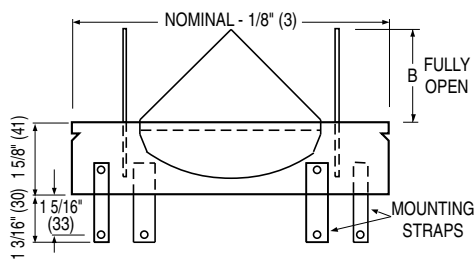
- Model 4275 Radial Damper

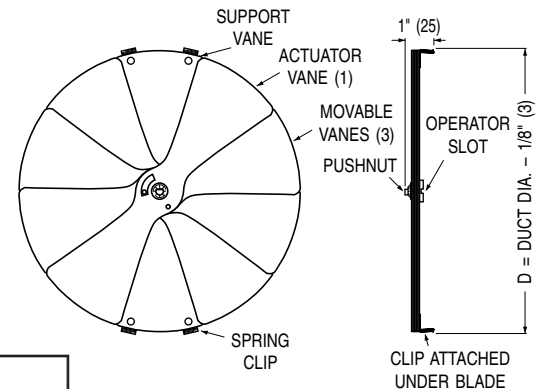

		NOMINAL SIZE						
B		6	8	10	12	14	15	16
4275		1 5/8 (41)	2 1/2 (64)	2 1/4 (57)	2 7/8 (73)	3 3/8 (86)	3 3/4 (95)	4 3/8 (111)

- Model 4250 Radial Sliding Blade Damper



Available Sizes: 6", 8", 10" and 12"
 (152, 203, 254 and 305) dia..

SCHEDULE TYPE:
PROJECT:
ENGINEER:
CONTRACTOR:

Dimensions are in inches (mm).

DATE	B SERIES	SUPERSEDES	DRAWING NO.
7 - 10 - 15	6500	2 - 13 - 06R	6500-8



SQUARE TO ROUND TRANSITION COLLARS

STEEL • DIFFUSER ACCESSORY

MODELS: SR, SR-O

DESCRIPTION:

Transition collars are for use with any Nailor square neck diffuser where a round duct connection is desired. Round necks are sized for flexible or hard duct connection. SR's ship loose for field installation and are supplied with barbed S-clips.

- Model SR
For direct attachment to diffuser neck. Round dampers may be added to neck.
- Model SR-O
For use over a square neck opposed blade damper.

CONSTRUCTION:

22 ga. corrosion-resistant steel.

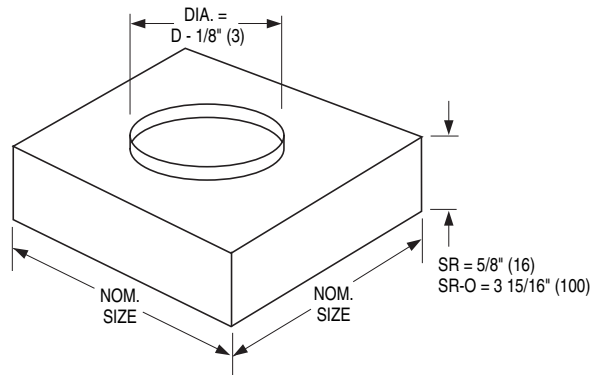

Square Neck Size (inches)	Round Neck Size D (inches)
6 x 6	4, 5, 6
8 x 8	4, 5, 6, 7, 8
9 x 9	6, 7, 8, 9
10 x 10	6, 7, 8, 9, 10
12 x 12	6, 8, 9, 10, 12
14 x 14	6, 8, 9, 10, 12, 14
15 x 15	6, 8, 10, 12, 14, 15
16 x 16	6, 8, 10, 12, 14, 15, 16
18 x 18	6, 8, 10, 12, 14, 15, 16, 18
20 x 20	6, 8, 10, 12, 14, 15, 16, 18, 20
21 x 21	6, 8, 10, 12, 14, 15, 16, 18, 20
22 x 22	6, 8, 10, 12, 14, 16, 18, 20
24 x 24	6, 8, 10, 12, 14, 15, 16, 18, 20, 22, 24

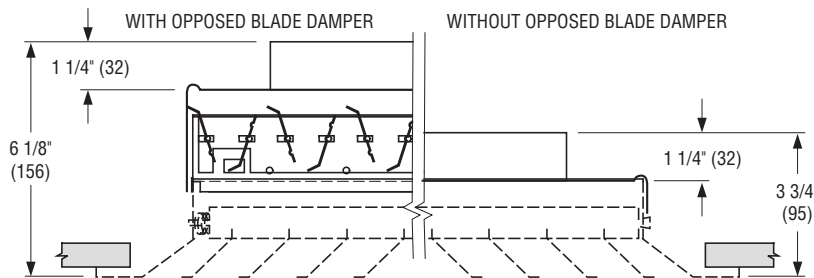

Example illustrated is Model 6500 Pattern Diffuser.

SCHEDULE TYPE:		Dimensions are in inches (mm).			
PROJECT:					
ENGINEER:	DATE	B SERIES	SUPERSEDES	DRAWING NO.	
CONTRACTOR:	3 - 4 - 16	ACC	10 - 27 - 05	ACC-SR	



**MOLDED INSULATION BLANKET
CEILING DIFFUSER ACCESSORY
24" x 24" MODULE FOR CEILING DIFFUSERS
MODEL/ACCESSORY: MIB**

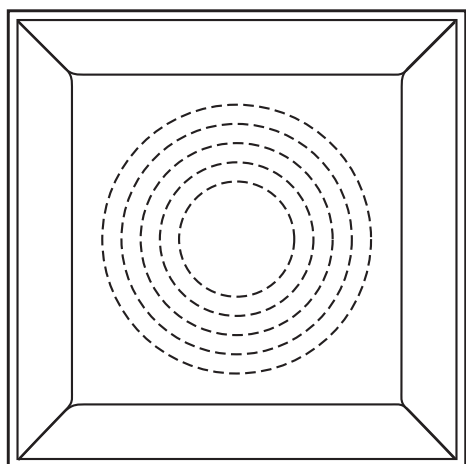
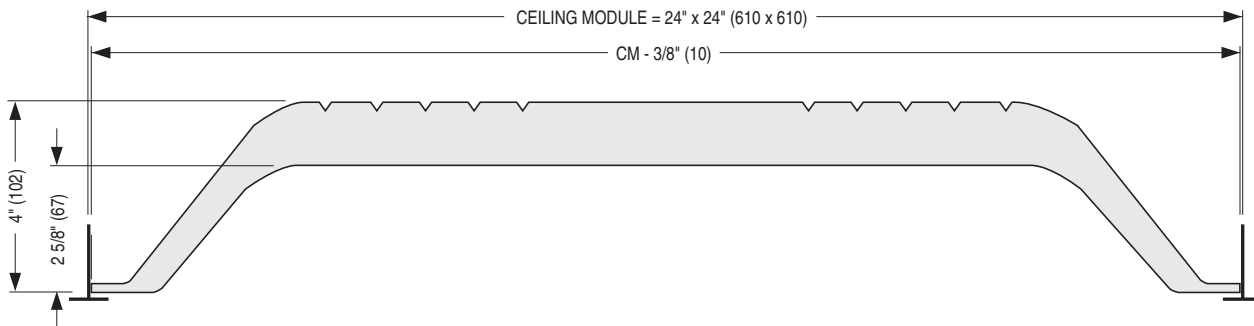

DESCRIPTION:

1. One piece molded fiberglass insulation blanket with foil back vapour barrier. 6.0 R-value.
2. Pre-scored plenum 6", 8", 10", 12" or 14" (152, 203, 254, 305 or 356) dia. for field cutting.
3. The Nailor Model MIB fits over the backpan of most full face 24" x 24" diffusers and provides thermal protection to reduce the risk of condensation forming on the diffuser face.
Compatible models include RNS, RNS2, RNS3, UNI, 6200, 6400, 6500 and 4320 series.
4. The Nailor Model MIB: resists ageing, thermal shock, is incombustible, immune to rot, corrosion, oxidation and insects.
5. Tested in compliance with surface burning characteristics (ASTM E-84) and erosion test (UL 181).
6. Standard finish has a black interior.

SCHEDULE TYPE:		Dimensions are in inches (mm).			
PROJECT:					
ENGINEER:	DATE	B SERIES	SUPERSEDES	DRAWING NO.	
CONTRACTOR:	1 - 16 - 17	MIB	2 - 1 - 11	MIB-1	

Nailor offers a selection of standard colors and finishes available on our grilles, registers and diffusers. For painted finishes, our state-of-the-art paint systems provide environmentally friendly finishing solutions with uniform coverage and coating thickness. The result is an exceptionally durable finish that resists scratching, corrosion and general wear. Additional facilities for special requirements, as well as a selection of anodized or brushed finishes, complete our ability to provide unmatched beauty and durability for any application.

NAILOR POWDER COAT PROPERTIES

FILM THICKNESS	2.0 to 3.0 mils
HARDNESS	2 H
IMPACT RESISTANCE	Direct: 160 inch - lbs. Reverse 160 inch - lbs.
SALT SPRAY	1000 hours

ELECTROCOATING PROPERTIES

FILM THICKNESS	.8 to 1.2 mils
HARDNESS	HB TO H
IMPACT RESISTANCE	80 inch - lbs
SALT SPRAY	100 hours

POWDER COAT

Nailor's powder coat is a high-tech thermosetting polyester powder coating with superior physical properties that provide excellent color and gloss retention. The finish offers extreme durability and hardness that resists scratching, chipping and general wear. Surface preparation includes degreasing and a chemical cleaning followed by a clean rinse before a final powder coat finish is applied and baked. The environmentally friendly Nailor powder coat system assures uniform coverage and color consistency resulting in a long lasting superior finish. Colors, including simulated anodizing, which is far more economical than color anodizing, can be selected from Nailor's standard color chart or non-standard colors and can be matched from sample chips provided to Nailor.

ELECTROCOATING

E-Coat is an environmentally friendly coating that provides complete coverage and a wide range of performance properties, formulated to meet corrosion, durability and other performance specifications. Electrocoating is a highly automated process in which paint is electrically deposited onto a metal foundation. Film build thickness is uniform and overall application efficiencies are in excess of 90%. Paint is consistent on all part-to-part surfaces, preventing sags, runs or drips. E-Coat offers flexibility, better first yield pass and quicker production times compared to other forms of paint applications. Electrocoating is an excellent solution that offers superior properties and uniform finish.

CLEAR ANODIZING (Aluminum products only)

Clear anodizing is a clear oxide coating that exemplifies an aluminum surface's natural oxide coating producing a hard, scratch resistant surface that is resistant to general wear and mild chemicals. The process provides a natural looking, virtually maintenance free finish that will endure for many years.

COLOR ANODIZING (Aluminum products only)

Color anodizing is an electrolytic process where, after standard anodizing procedures, colored metallic pigments penetrate the oxide surface pores producing a corrosion resistant, colorfast finish. The process results in a natural metallic appearance that requires little maintenance.

BRUSHED AND CLEAR COAT

Available on specific aluminum products (consult applicable product page for availability). Surface is brushed to achieve a scratch finish texture before being degreased and chemically cleaned. A clear lacquer coating is then applied to provide a durable protective finish.

#4 BRUSHED SATIN POLISHED (Stainless Steel products only)

Surface is polished to ASTM A480 #4 standard to achieve a bright durable finish that is resistant to mild chemicals and corrosion. A final coating is not required due to the inherent anti-corrosion properties of the stainless steel.

PRIME COAT

Prime coat provides a stable base for painting in the field. Surface pretreatment includes degreasing and a chemical cleaning before an alkyd prime coat is applied. After a thorough cleaning for dust, etc. that can contaminate the final finish and cause premature flaking or peeling, finish coat should be field applied as soon as possible.

PAINT PREPARED ALUMINUM (Aluminum products only)

Allows for field applied paint. Surface preparation includes degreasing and a chemical cleaning followed by a clean rinse. Finish coat should be field applied as soon as possible.

MILL FINISH

Surface is left untreated and requires cleaning, degreasing, etc. in the field before final finish can be applied if required.



Nailor[®]
Industries Inc.

STANDARD AND OPTIONAL FINISHES FOR GRILLES AND DIFFUSERS

The following standard colors and finishes are available on applicable Nailor air distribution products. Consult individual product pages for availability

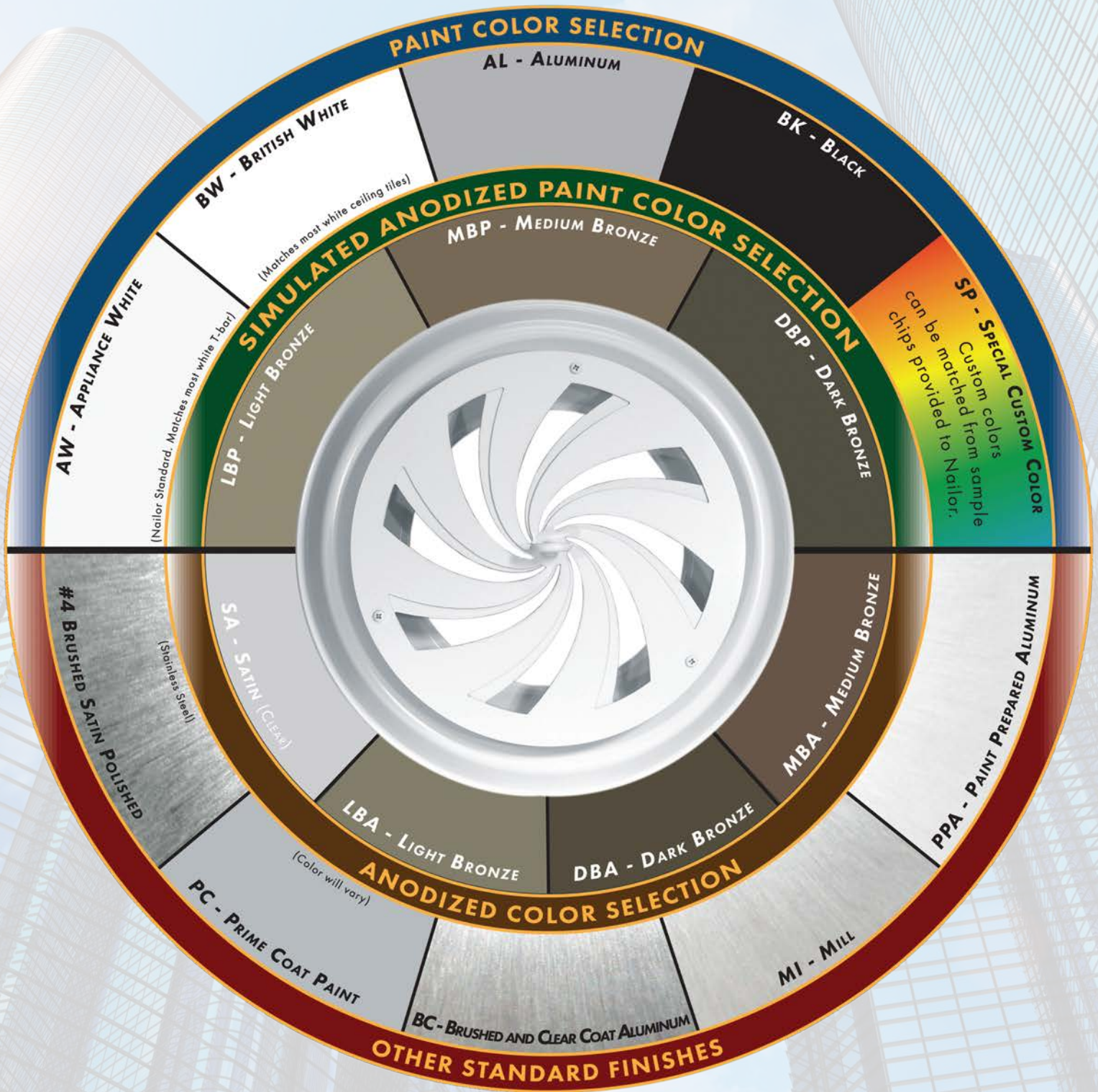

The pictured finishes have been represented as best as possible within printing limitations. However, actual finish may vary. Contact your Nailor representative for a color chip sample on the material specified for a more accurate representation.

DBK - Black (for registers ordered with factory mounted dampers) - **BA** - Perforated Diffusers (4300 series only) Appliance White (AW) face with black back pan and pattern controllers.

"Complete Air Control and Distribution Solutions."

WGDSOF2015

www.nailor.com

PERFORMANCE DATA:

MODELS 6500 AND 6200 • ROUND NECK

NOMINAL NECK SIZE	BLOW PATTERNS	NECK VELOCITY TP	400 .026	600 .058	800 .103	900 .130	1000 .161	1200 .231	1400 .315
18 x 18 6" ROUND	RETURN FACTORS —SP=0.7 TP NC + 0	CFM NC	78 —	118 11	157 19	176 21	196 25	235 30	274 35
	4A	CFM/SIDE THROW, FT.	20 2-4-6	29 4-7-10	39 6-8-11	44 7-8-12	49 7-8-13	59 8-9-14	69 8-10-15
	3A	CFM/SIDE THROW, FT.	20 29 2-4-6 2-4-7	29 44 4-7-10 4-8-11	39 59 6-8-11 7-9-12	44 66 7-8-12 8-9-13	49 74 7-8-13 8-9-14	59 88 8-9-14 9-10-15	69 103 8-10-15 9-11-17
	2S 2G	CFM/SIDE THROW, FT.	39 3-4-9	59 5-6-13	78 6-9-15	88 6-10-16	98 7-11-17	118 8-13-18	137 9-14-20
	1S	CFM/SIDE THROW, FT.	78 4-7-14	118 6-10-18	157 9-14-21	176 10-15-23	196 11-16-24	235 12-18-26	274 13-19-28
18 x 18 8" ROUND	RETURN FACTORS —SP=0.8 TP NC + 0	CFM NC	140 —	209 13	279 21	314 23	349 27	419 32	489 37
	4A	CFM/SIDE THROW, FT.	35 4-8-10	52 6-9-13	70 8-10-15	79 9-11-15	87 9-12-17	105 10-13-19	122 11-14-20
	3A	CFM/SIDE THROW, FT.	35 52 4-8-10 4-9-11	52 79 6-9-13 7-10-14	70 105 8-10-15 9-11-17	79 118 9-11-15 10-12-17	87 131 9-12-17 10-13-19	105 157 10-13-19 11-14-21	122 183 11-14-0 12-15-22
	2S 2G	CFM/SIDE THROW, FT.	70 5-17-14	105 6-9-17	140 8-13-20	157 9-14-22	175 10-15-23	209 12-17-25	244 10-13-1
	1S	CFM/SIDE THROW, FT.	140 7-12-19	209 9-14-24	279 13-19-28	314 14-21-30	349 15-22-32	419 16-24-34	489 17-26-37
18 x 18 10" ROUND	RETURN FACTORS —SP=0.9 TP NC + 2	CFM NC	218 —	327 16	436 24	491 26	545 30	654 35	763 40
	4A	CFM/SIDE THROW, FT.	55 4-8-12	82 8-11-17	109 10-13-19	123 11-14-20	136 12-15-21	164 12-16-23	191 13-17-24
	3A	CFM/SIDE THROW, FT.	55 82 4-8-12 4-9-13	82 123 8-11-17 9-12-19	109 164 10-13-19 11-14-21	123 184 11-14-20 12-15-22	136 204 12-15-21 13-17-23	164 245 12-16-23 13-18-25	191 286 13-17-24 14-19-26
	2S 2G	CFM/SIDE THROW, FT.	109 5-7-15	164 7-11-22	218 10-15-25	245 12-17-27	273 13-19-28	327 14-21-30	382 15-23-34
	1S	CFM/SIDE THROW, FT.	218 7-12-22	327 12-17-31	436 15-23-25	491 17-26-37	545 19-27-39	654 20-29-42	763 22-32-45
18 x 18 12" ROUND	RETURN FACTORS —SP=1.0 TP NC + 3	CFM NC	314 —	471 18	628 26	707 28	785 32	942 37	1099 42
	4A	CFM/SIDE THROW, FT.	79 6-9-15	118 8-11-18	157 10-15-23	177 13-17-24	196 14-18-25	236 15-20-28	275 17-21-30
	3A	CFM/SIDE THROW, FT.	79 118 6-9-15 7-10-17	118 177 8-11-18 9-12-20	157 236 10-15-23 11-17-25	177 265 13-17-24 14-19-26	196 294 14-18-25 15-20-28	236 353 15-20-28 17-23-31	275 412 17-21-30 19-23-33
	2S 2G	CFM/SIDE THROW, FT.	157 6-9-19	236 9-14-26	314 11-16-29	353 14-21-32	393 15-23-34	471 16-24-38	550 18-27-40
	1S	CFM/SIDE THROW, FT.	314 9-14-28	471 14-21-37	628 19-28-42	707 21-32-45	785 23-34-47	942 24-36-51	1099 27-39-55
18 x 18 14" ROUND	RETURN FACTORS —SP=1.1 TP NC + 4	CFM NC	427 —	641 20	854 28	961 30	1068 34	1282 39	1495 44
	4A	CFM/SIDE THROW, FT.	107 7-10-19	160 10-15-23	214 14-19-26	240 15-20-29	267 17-21-30	320 19-23-32	374 21-26-38
	3A	CFM/SIDE THROW, FT.	107 160 7-10-19 8-11-21	160 240 10-15-23 11-17-25	214 320 14-19-26 15-21-29	240 360 15-20-29 17-22-32	267 401 17-21-30 19-23-33	320 481 19-23-32 21-25-35	374 561 21-26-38 23-29-42
	2S 2G	CFM/SIDE THROW, FT.	214 7-11-22	320 11-16-31	427 14-22-36	481 16-24-38	534 18-27-40	641 19-28-43	748 21-31-47
	1S	CFM/SIDE THROW, FT.	427 11-16-32	641 16-24-42	854 24-33-50	961 24-37-52	1068 27-39-55	1282 29-42-60	1495 33-45-65
18 x 18 16" ROUND	RETURN FACTORS —SP=1.3 TP NC + 6	CFM NC	558 —	837 22	1116 30	1256 32	1395 36	1674 41	1953 46
	4A	CFM/SIDE THROW, FT.	140 8-12-21	209 12-19-26	279 17-21-31	314 19-23-32	349 20-25-35	419 22-28-42	488 24-30-48
	3A	CFM/SIDE THROW, FT.	140 209 8-12-21 9-13-23	209 314 12-19-26 13-21-29	279 419 17-21-31 19-23-34	314 471 19-23-32 21-25-35	349 523 20-25-35 22-28-39	419 628 22-28-42 24-31-46	488 732 24-30-48 26-33-53
	2S 2G	CFM/SIDE THROW, FT.	279 8-13-25	419 13-19-35	558 16-25-41	628 19-28-43	698 20-30-45	837 23-34-49	977 26-37-54
	1S	CFM/SIDE THROW, FT.	558 13-19-38	837 19-28-49	1116 25-38-57	1256 28-42-60	1395 31-44-63	1674 36-48-69	1953 42-52-75

For performance notes, see page D37.

PERFORMANCE DATA:

MODELS 6500 AND 6200 • RECTANGULAR NECK

NOMINAL NECK SIZE	BLOW PATTERNS	NECK VELOCITY TP	300 .033		400 .058		500 .090		600 .130		700 .177		800 .231		900 .293	
			CFM NC	1800 18	2400 25	3000 31	3600 36	4200 40	4800 43	5400 46						
36 x 24 6.0 SQ. FT.	RETURN FACTORS —SP=3.3 TP NC + 8	CFM NC	1800 18	2400 25	3000 31	3600 36	4200 40	4800 43	5400 46							
	4B 4C	CFM/SIDE THROW, FT.	600 300 29-37-51 19-22-31	800 400 34-41-58 22-25-37	1000 500 39-48-66 25-29-41	1200 600 41-51-70 27-31-44	1400 700 44-54-75 29-32-48	1600 800 49-59-80 31-37-51	1800 900 53-63-85 32-37-54							
	4E	CFM/SIDE THROW, FT.	450 450 25-31-42 24-31-42	600 600 29-37-51 29-37-51	750 750 32-41-58 32-41-58	900 900 35-44-61 35-44-61	1050 1050 37-48-66 37-48-66	1200 1200 41-51-71 41-51-71	1350 1350 42-54-75 42-54-75							
	3A1	CFM/SIDE THROW, FT.	750 300 31-37-54 19-22-31	1000 400 37-42-61 22-25-37	1250 500 41-49-70 25-29-41	1500 600 44-54-75 27-31-44	1750 700 48-58-80 29-32-48	2000 800 51-61-85 31-37-51	2250 900 54-65-90 32-37-54							
	3A2	CFM/SIDE THROW, FT.	676 562 27-32-48 24-29-41	900 750 34-37-54 27-32-48	1125 937 34-42-61 31-37-54	1350 1125 37-48-66 32-39-58	1575 1312 39-51-71 35-42-61	1800 1500 42-54-75 37-44-66	2025 1687 48-58-80 41-49-70							
	2A	CFM/SIDE THROW, FT.	900 32-41-56	1200 37-48-65	1500 42-54-73	1800 48-58-78	2100 51-61-85	2400 54-66-90	2700 58-70-97							
	2B	CFM/SIDE THROW, FT.	900 32-41-56	1200 37-48-65	1500 42-54-73	1800 48-58-78	2100 51-61-85	2400 54-66-90	2700 58-70-97							
	2C 2D	CFM/SIDE THROW, FT.	1200 600 37-42-63 25-31-42	1600 800 41-51-71 29-37-51	2000 1000 48-58-82 32-41-58	2400 1200 51-61-87 35-44-61	2800 1400 54-66-95 37-48-66	3200 1600 58-71-99 41-51-71	3600 1800 63-75-107 42-54-75							
	2E	CFM/SIDE THROW, FT.	1200 600 37-42-63 25-31-42	1600 800 41-51-71 29-37-51	2000 1000 48-58-82 32-41-58	2400 1200 51-61-87 35-44-61	2800 1400 54-66-95 37-48-66	3200 1600 58-71-99 41-51-71	3600 1800 63-75-107 42-54-75							
	1A 1B	CFM/SIDE THROW, FT.	1800 41-51-70	2400 48-58-80	3000 54-66-90	3600 58-70-99	4200 61-75-105	4800 66-80-114	5400 70-85-122							
36 x 30 7.5 SQ. FT.	RETURN FACTORS —SP=3.4 TP NC + 8	CFM NC	2250 19	3000 26	3750 32	4500 37	5250 41	6000 44	6750 47							
	4B 4C	CFM/SIDE THROW, FT.	657 468 29-37-51 20-25-34	875 625 34-41-58 24-29-39	1093 782 39-48-66 27-32-44	1313 937 41-51-70 29-37-49	1532 1093 44-54-75 31-37-53	1750 1250 49-59-80 32-41-56	1969 1406 53-63-85 37-42-59							
	3A1	CFM/SIDE THROW, FT.	890 468 32-41-56 20-25-34	1187 625 37-48-65 24-29-39	1484 782 42-54-73 27-32-44	1781 937 48-58-78 29-37-49	2078 1093 51-61-85 31-37-53	2375 1250 54-66-90 32-41-56	2672 1406 58-70-97 37-42-59							
	3A2	CFM/SIDE THROW, FT.	787 675 31-37-54 22-27-37	1050 900 37-42-61 25-31-42	1312 1125 41-49-70 29-34-49	1575 1350 44-54-75 31-37-54	1837 1575 48-58-80 32-39-58	2100 1800 51-61-85 37-42-61	2362 2025 54-65-90 37-48-65							
	2A	CFM/SIDE THROW, FT.	1125 34-42-59	1500 39-49-68	1875 44-56-76	2250 49-59-83	2625 53-65-88	3000 56-68-97	3375 59-73-102							
	2B	CFM/SIDE THROW, FT.	1125 34-42-59	1500 39-49-68	1875 44-56-76	2250 49-59-83	2625 53-65-88	3000 56-68-97	3375 59-73-102							
	2C 2D	CFM/SIDE THROW, FT.	1312 938 37-42-63 29-37-51	1750 1250 41-51-71 34-41-58	2188 1562 48-58-82 39-48-66	2625 1875 51-61-87 41-51-70	3063 2187 54-66-95 44-54-75	3500 2500 58-71-99 49-59-80	3938 2812 63-75-107 53-63-85							
	2E	CFM/SIDE THROW, FT.	1312 938 37-42-63 29-37-51	1750 1250 41-51-71 34-41-58	2188 1562 48-58-82 39-48-66	2625 1875 51-61-87 41-51-70	3063 2187 54-66-95 44-54-75	3500 2500 58-71-99 49-59-80	3938 2812 63-75-107 53-63-85							
	1A 1B	CFM/SIDE THROW, FT.	2250 48-60-82	3000 56-68-94	3750 64-78-106	4500 68-82-116	5250 72-88-124	6000 78-94-134	6750 82-100-144							

Notes:

1. Core style 4E is sized to give equal flow as near as possible in directions A and B.
2. For core styles 1A, 1B, 2A and 2B, the "A" direction is shown. Throw correction factor for "B" direction is: $A \times .82 = B$.

- CFM** - cubic feet per minute
TP - total pressure - inches w.g.
T - throw in feet
NC - Noise Criteria (values) based on 10 dB room absorption, re 10^{-12} watts.
Neck Velocity – feet per minute

Performance Notes:

1. Throw values are given for terminal velocities of 150, 100 and 50 fpm under isothermal conditions. Data applies to ceiling mounted units when the maximum coanda effect applies. When no ceiling is present (exposed duct), throws are reduced by approximately 25%.
2. Sound levels in performance tables are for steel construction – **Model 6500**. Apply the following corrections for aluminum construction – **Model 6200**.
 TP = Listed value x 1.25.
 NC = Listed value + 4.
3. Performance data as tabulated is for supply air conditions. Correction factors for return air application - see next page.
4. Correction factors for adjustable models - see next page.
5. Correction factors for round inlets - see next page.
6. Data derived from tests conducted in accordance with ANSI/ASHRAE Standard 70 – 2006.

PERFORMANCE DATA CORRECTIONS:

MODELS 6500 AND 6200

CORRECTION FACTORS FOR RETURN INLET

If the unit is used as a return inlet, the performance data is obtained by applying the return corrections, as follows:

- Add the NC correction at the left side of the table to the NC value listed in the performance table.
- Multiply the listed SP factor at the left side of the table by the total pressure (TP) listed at the top of the table.

CORRECTION FACTORS FOR MODELS 6550 AND 6250 (ADJUSTABLE PATTERN CONTROLLERS) – TABLE 2

Refer to the performance data for the **Models 6500 and 6200**. Apply the corrections from Table 2 to the data for square, 4-way core styles, as follows:

- NC = listed + correction
- Total Pressure = listed x factor
- Horizontal Throw = listed
- Vertical Throw = listed x factor

Apply the throw factor to the 50 fpm terminal velocity throw only.

Example:

18" x 18", **Model 6500**, 1350 cfm, 20°F temperature difference heating, vertical projection, (Page D23).

- NC = 31 + 6 = 37
- TP = .13 x 2.1 = .273
- Throw = 36 x .9 = 32.4 feet @ 50 fpm terminal velocity.

CORRECTION FACTORS WITH SQUARE TO ROUND INLET ADAPTOR – TABLE 3

- Add the NC correction factor from Table 3 and the NC value listed in the performance tables.
- Multiply the correction factor from Table 3 by the listed total pressure in the performance tables.
- Multiply the correction factor from Table 3 by the listed throws in the performance tables.

Example:

12" x 12" unit with 10" round adaptor handling 500 cfm supply air. (Page D23).

- NC = 23 + 7 = 30
- Total Pressure = .09 x 1.65 = 0.149
- Throw = 21 x 1.15 = 24.15 feet @ 50 fpm terminal velocity.

Example:

12" x 12" unit handling 600 cfm of return air. (Page D23).

- Return NC = 28 + 4 = 32.
- Return negative SP = 1.3 x (-.13) = -.169.

TABLE 2 Correction Factors 6550/6250 Adjustable

NECK SIZE	NC (add)		TOTAL PRESSURE (multiply)		VERTICAL THROW (multiply)			
					COOLING, ΔT		HEATING, ΔT	
	H	V	H	V	20°F	0°F	20°F	40°F
6 x 6	2	6	1.2	1.5	1.3	1.1	0.8	0.6
9 x 9	2	6	1.4	2.1	1.5	1.2	0.9	0.6
12 x 12	2	6	1.4	2.1	1.6	1.3	1.0	0.6
15 x 15	2	6	1.4	2.1	1.7	1.3	1.0	0.6
18 x 18	2	6	1.4	2.1	1.7	1.3	0.9	0.6
21 x 21	2	6	1.4	2.1	1.7	1.3	0.8	0.5
24 x 24	2	6	1.6	2.2	1.5	1.1	0.7	0.3

TABLE 3 Correction Factors for SR Adaptors

SQUARE INLET	ROUND INLET	NC (add)	TP (multiply)	THROW (multiply)		
				150	100	50
6 x 6	5	7	1.65	1.10	1.10	1.15
9 x 9	6	17	3.50	1.15	1.15	1.20
9 x 9	8	4	1.40	1.10	1.10	1.10
12 x 12	8	17	3.50	1.15	1.15	1.20
12 x 12	10	7	1.65	1.10	1.10	1.15
15 x 15	10	17	3.50	1.15	1.15	1.20
15 x 15	12	9	1.90	1.10	1.10	1.15
15 x 15	14	3	1.25	1.05	1.05	1.10
18 x 18	12	17	3.50	1.15	1.15	1.20
18 x 18	14	10	2.00	1.10	1.10	1.15
18 x 18	16	5	1.45	1.10	1.10	1.10
21 x 21	14	17	3.70	1.15	1.15	1.20
21 x 21	16	11	2.25	1.10	1.10	1.15
21 x 21	18	6	1.60	1.10	1.10	1.10
21 x 21	20	3	1.20	1.05	1.05	1.10
24 x 24	16	17	3.50	1.15	1.15	1.20
24 x 24	18	12	2.35	1.10	1.10	1.15
24 x 24	20	7	1.65	1.10	1.10	1.15
24 x 24	22	4	1.33	1.05	1.05	1.10

PERFORMANCE DATA:

MODELS 6500IV AND 6200IV • SQUARE NECK • INDUCTION VANES

NOMINAL NECK SIZE	BLOW PATTERNS	NECK VELOCITY TP	300 .035	400 .062	500 .097	600 .140	700 .191	800 .249	900 .316
6 x 6 .25 SQ. FT.	RETURN FACTORS —SP=1.1 TP NC + 1	CFM NC	75 —	100 14	125 21	150 26	175 30	200 35	225 39
	4A	CFM/SIDE THROW, FT.	19 3-4-6	25 3-5-8	31 5-6-8	37 5-6-9	44 6-7-10	50 6-7-10	56 7-8-10
	3A	CFM/SIDE THROW, FT.	19 28 3-4-6 4-6-9	25 38 3-5-8 5-7-10	31 47 5-6-8 6-8-11	37 56 5-6-9 6-9-12	44 66 6-7-10 7-10-13	50 75 6-7-10 7-10-14	56 85 7-8-10 8-10-14
	2S 2G	CFM/SIDE THROW, FT.	37 6-7-10	50 7-8-11	62 8-9-13	75 9-10-14	88 10-10-14	100 10-10-15	113 10-11-16
	1S	CFM/SIDE THROW, FT.	75 7-9-12	100 8-10-14	125 9-11-15	150 10-12-18	175 10-13-18	200 11-14-19	225 12-14-20
9 x 9 .56 SQ. FT.	RETURN FACTORS —SP=1.2 TP NC + 2	CFM NC	170 —	225 18	280 24	340 30	395 35	450 39	505 42
	4A	CFM/SIDE THROW, FT.	42 5-6-10	56 6-8-11	70 8-9-12	84 8-10-13	98 9-10-14	112 9-11-15	126 10-12-16
	3A	CFM/SIDE THROW, FT.	42 63 5-6-10 7-9-11	56 85 6-8-11 8-10-14	70 106 8-9-12 9-10-15	84 127 8-10-13 10-11-16	98 148 9-10-14 10-12-17	112 169 9-11-15 10-13-18	126 190 10-12-16 11-14-19
	2S 2G	CFM/SIDE THROW, FT.	84 7-8-12	112 9-10-14	141 10-12-16	169 10-13-18	197 11-14-18	225 12-14-20	253 13-15-22
	1S	CFM/SIDE THROW, FT.	169 10-12-16	225 11-14-18	282 13-15-21	338 14-18-23	394 14-18-25	450 15-19-26	507 18-20-28
12 x 12 1.0 SQ. FT.	RETURN FACTORS —SP=1.3 TP NC + 4	CFM NC	300 14	400 21	500 27	600 32	700 37	800 40	900 43
	4A	CFM/SIDE THROW, FT.	75 6-10-12	100 9-11-14	125 10-12-17	150 11-14-18	175 11-14-19	200 12-16-20	225 14-17-22
	3A	CFM/SIDE THROW, FT.	75 112 6-10-12 9-11-15	100 150 9-11-14 11-13-17	125 187 10-12-17 11-14-19	150 225 11-14-18 12-15-21	175 262 11-14-19 13-16-22	200 300 12-16-20 14-17-24	225 338 14-17-22 15-18-25
	2S 2G	CFM/SIDE THROW, FT.	150 10-12-16	200 12-14-20	250 14-15-22	300 14-16-23	350 15-17-25	400 16-20-27	450 17-20-29
	1S	CFM/SIDE THROW, FT.	300 13-16-22	400 14-18-26	500 17-20-30	600 18-21-31	700 18-22-33	800 20-23-33	900 22-26-38
15 x 15 1.56 SQ. FT.	RETURN FACTORS —SP=1.8 TP NC + 4	CFM NC	465 14	625 23	780 29	935 34	1090 37	1250 43	1400 45
	4A	CFM/SIDE THROW, FT.	117 10-13-17	156 11-14-19	195 13-15-22	234 14-17-23	273 15-18-24	312 16-19-26	350 17-21-28
	3A	CFM/SIDE THROW, FT.	117 175 10-13-17 11-14-18	156 234 11-14-19 14-18-23	195 292 13-15-22 15-18-25	234 351 14-17-23 17-18-27	273 409 15-18-24 18-20-29	312 468 16-19-26 18-23-31	350 527 17-21-28 20-23-34
	2S 2G	CFM/SIDE THROW, FT.	234 13-16-22	312 15-18-25	390 17-20-29	468 18-22-32	546 19-23-34	625 22-25-36	700 22-28-38
	1S	CFM/SIDE THROW, FT.	467 17-20-29	625 18-23-34	780 21-26-38	935 23-29-41	1090 24-31-44	1250 26-34-46	1400 29-35-49
18 x 18 2.25 SQ. FT.	RETURN FACTORS —SP=2.1 TP NC + 6	CFM NC	675 16	900 25	1125 31	1350 35	1575 40	1800 43	2025 46
	4A	CFM/SIDE THROW, FT.	168 12-15-20	225 14-16-23	281 15-19-26	337 16-20-29	394 18-22-30	450 19-23-33	506 20-25-34
	3A	CFM/SIDE THROW, FT.	168 253 12-15-20 14-18-23	225 338 14-16-23 16-20-26	281 422 15-19-26 18-22-30	337 506 16-20-29 20-26-34	394 590 18-22-30 21-26-36	450 675 19-23-33 22-28-38	506 760 20-25-34 26-29-41
	2S 2G	CFM/SIDE THROW, FT.	337 15-18-26	450 18-21-30	562 19-24-34	675 21-25-37	787 24-27-39	900 24-28-42	1012 26-31-44
	1S	CFM/SIDE THROW, FT.	675 20-26-36	900 24-29-41	1125 27-34-46	1350 29-36-49	1575 31-38-53	1800 34-42-56	2025 37-44-60

For performance notes, see D44.

D

CEILING DIFFUSERS

PERFORMANCE DATA:

MODELS 6500IV AND 6200IV • SQUARE NECK • INDUCTION VANES

NOMINAL NECK SIZE	BLOW PATTERNS	NECK VELOCITY TP	300 .035	400 .062	500 .097	600 .140	700 .191	800 .249	900 .316
21 x 21 3.06 SQ. FT.	RETURN FACTORS —SP=2.6 TP NC + 8	CFM NC	915 18	1225 26	1530 32	1835 36	2140 41	2450 44	2750 47
			A B	A B	A B	A B	A B	A B	A B
	4A	CFM/SIDE THROW, FT.	230 14-17-24	306 15-20-27	382 17-22-31	460 18-24-33	535 20-27-35	612 21-27-37	688 22-31-41
	3A	CFM/SIDE THROW, FT.	230 345 12-15-21 16-20-27	306 460 14-18-23 18-22-31	382 573 15-20-27 21-25-36	460 688 16-21-29 22-27-40	535 802 18-22-31 23-29-42	612 918 18-23-32 27-31-45	688 1030 20-27-36 27-34-47
2S	2G	CFM/SIDE THROW, FT.	458 18-22-31	612 20-25-36	765 22-28-40	917 25-31-44	1070 27-34-47	1225 27-36-50	1375 31-38-48
	1S	CFM/SIDE THROW, FT.	917 23-30-41	1225 27-34-47	1530 31-40-54	1835 34-42-57	2140 37-45-62	2450 40-48-66	2750 42-51-70
24 x 24 4.0 SQ. FT.	RETURN FACTORS —SP=2.7 TP NC + 8	CFM NC	1200 19	1600 27	2000 33	2400 37	2800 41	3200 45	3600 48
			A B	A B	A B	A B	A B	A B	A B
	4A	CFM/SIDE THROW, FT.	300 16-19-26	400 19-22-32	500 22-25-35	600 23-26-38	700 25-28-41	800 26-32-44	900 28-32-46
	3A	CFM/SIDE THROW, FT.	300 450 16-19-26 18-22-31	400 600 19-22-32 19-25-37	500 750 22-25-35 23-29-42	600 900 23-26-38 25-30-45	700 1050 25-28-41 29-33-47	800 1200 26-32-44 29-34-51	900 1350 28-32-46 31-38-54
2S	2G	CFM/SIDE THROW, FT.	600 20-26-36	800 24-29-41	1000 27-34-46	1200 29-36-49	1400 31-38-53	1600 34-42-56	1800 37-44-60
	1S	CFM/SIDE THROW, FT.	1200 28-32-47	1600 30-38-54	2000 36-43-62	2400 38-46-66	2800 41-50-72	3200 43-54-74	3600 47-56-81
30 x 30 6.25 SQ. FT.	RETURN FACTORS —SP=3.1 TP NC + 8	CFM NC	1875 20	2500 28	3125 34	3750 39	4375 43	5000 46	5625 50
			A B	A B	A B	A B	A B	A B	A B
	4A	CFM/SIDE THROW, FT.	469 20-25-34	625 23-29-38	782 27-32-44	937 29-35-49	1093 30-37-52	1250 32-40-55	1406 37-42-58
	3A	CFM/SIDE THROW, FT.	469 703 20-25-34 22-27-39	625 938 23-29-38 26-31-46	782 1172 27-32-44 28-35-51	937 1405 29-35-49 31-39-55	1093 1640 30-37-52 33-39-59	1250 1875 32-40-55 35-46-62	1406 2110 37-42-58 39-48-66
2S	2G	CFM/SIDE THROW, FT.	937 26-32-44	1250 30-38-50	1562 34-42-58	1875 38-46-62	2187 40-48-66	2500 42-52-70	2812 46-54-76
	1S	CFM/SIDE THROW, FT.	1875 34-42-58	2500 39-48-66	3125 45-55-74	3750 48-58-82	4375 50-62-87	5000 55-66-117	5625 58-70-98
36 x 36 9.0 SQ. FT.	RETURN FACTORS —SP=3.6 TP NC + 9	CFM NC	2700 22	3600 29	4500 35	5400 40	6300 44	7200 48	8100 52
			A B	A B	A B	A B	A B	A B	A B
	4A	CFM/SIDE THROW, FT.	675 24-30-41	900 27-33-46	1125 31-37-54	1350 33-41-59	1575 35-42-62	1800 41-46-66	2025 41-51-70
	3A	CFM/SIDE THROW, FT.	675 1010 24-30-41 27-35-46	900 1350 27-33-46 32-38-54	1125 1687 31-37-54 37-45-62	1350 2025 33-41-59 38-48-66	1575 2362 35-42-62 42-51-70	1800 2700 41-46-66 46-56-75	2025 3038 41-51-70 50-59-80
2S	2G	CFM/SIDE THROW, FT.	1350 32-36-54	1800 34-43-61	2250 40-49-69	2700 43-52-74	3150 46-56-81	3600 49-61-83	4050 54-63-90
	1S	CFM/SIDE THROW, FT.	2700 39-49-68	3600 47-56-79	4500 53-64-91	5400 58-68-98	6300 61-73-105	7200 66-78-114	8100 70-85-120

D
CEILING DIFFUSERS

CFM - cubic feet per minute
 Neck Velocity - feet per minute
 TP - total pressure - inches w.g.
 NC - Noise Criteria (values) based on 10 dB room absorption, re 10⁻¹² watts.

Performance Notes:

1. Throw values are given for terminal velocities of 150, 100 and 50 fpm under isothermal conditions. Data applies to ceiling mounted units when the maximum coanda effect applies. When no ceiling is present (exposed duct), throws are reduced by approximately 25%.

2. Sound levels in performance tables are for steel construction – **Model 6500IV**. Apply the following corrections for aluminum construction – **Model 6200IV**.

TP = Listed value x 1.25.
 NC = Listed value + 4.

3. Performance data as tabulated is for supply air conditions. Correction factors for return air application - see next page.
 4. Correction factors for round inlets - see next page.
 5. Data derived from tests conducted in accordance with ANSI/ASHRAE Standard 70 – 2006.

PERFORMANCE DATA CORRECTIONS :

MODEL SERIES 6500IV AND 6200IV

CORRECTION FACTORS FOR RETURN INLET

If the unit is used as a return inlet, the performance data is obtained by applying the return corrections, as follows:

- Add the NC correction at the left side of the table to the NC value listed in the performance table.
- Multiply the listed SP factor at the left side of the table by the total pressure (TP) listed at the top of the table.

Example:

12" x 12" unit handling 600 cfm of return air. (Page D43).

- Return NC = 32 + 4 = 36.
- Return negative SP = 1.3 x (- .14) = - .182.

CORRECTION FACTORS WITH SQUARE TO ROUND INLET ADAPTOR

- Add the NC correction factor from Table 2 and the NC value listed in the performance tables.
- Multiply the correction factor from Table 2 by the listed total pressure in the performance tables.
- Multiply the correction factor from Table 2 by the listed throws in the performance tables.

Example:

12" x 12" unit with 10" round adaptor handling 500 cfm supply air. (Page D43).

- NC = 27 + 7 = 34
- Total Pressure = .097 x 1.65 = 0.160
- Throw = 17 x 1.15 = 19.55 feet @ 50 fpm terminal velocity.

TABLE 2 Correction Factors for SR Adaptors

SQUARE INLET	ROUND INLET	NC (add)	TP (multiply)	THROW (multiply)		
				150	100	50
6 x 6	5	7	1.65	1.10	1.10	1.15
9 x 9	6	17	3.50	1.15	1.15	1.20
9 x 9	8	4	1.40	1.10	1.10	1.10
12 x 12	8	17	3.50	1.15	1.15	1.20
12 x 12	10	7	1.65	1.10	1.10	1.15
15 x 15	10	17	3.50	1.15	1.15	1.20
15 x 15	12	9	1.90	1.10	1.10	1.15
15 x 15	14	3	1.25	1.05	1.05	1.10
18 x 18	12	17	3.50	1.15	1.15	1.20
18 x 18	14	10	2.00	1.10	1.10	1.15
18 x 18	16	5	1.45	1.10	1.10	1.10
21 x 21	14	17	3.70	1.15	1.15	1.20
21 x 21	16	11	2.25	1.10	1.10	1.15
21 x 21	18	6	1.60	1.10	1.10	1.10
21 x 21	20	3	1.20	1.05	1.05	1.10
24 x 24	16	17	3.50	1.15	1.15	1.20
24 x 24	18	12	2.35	1.10	1.10	1.15
24 x 24	20	7	1.65	1.10	1.10	1.15
24 x 24	22	4	1.33	1.05	1.05	1.10

PERFORMANCE DATA:

MODELS 6500 AND 6200 • RECTANGULAR NECK

NOMINAL NECK SIZE	BLOW PATTERNS	NECK VELOCITY TP	300 .033		400 .058		500 .090		600 .130		700 .177		800 .231		900 .293	
			CFM NC	— —	A	B	A	B	A	B	A	B	A	B	A	B
9 x 6 .375 SQ. FT.	RETURN FACTORS —SP=1.2 TP NC + 0	CFM NC	110 —	—	150 14	—	185 20	—	225 25	—	260 29	—	300 33	—	335 37	—
	4B	CFM/SIDE THROW, FT.	37 18 7-11-13 5-6-10	50 25 10-12-16 6-7-11	62 31 11-13-18 7-10-12	75 37 12-14-19 7-10-13	87 44 12-16-20 10-11-14	100 50 13-17-22 10-12-15	112 56 14-18-23 11-12-16							
	3A1	CFM/SIDE THROW, FT.	47 18 10-11-14 5-6-10	62 25 11-12-17 6-7-11	78 31 12-13-19 7-10-12	94 37 13-14-20 7-10-13	109 44 14-16-22 10-11-14	125 50 14-17-23 10-12-15	140 56 16-18-26 11-12-16							
	3A2	CFM/SIDE THROW, FT.	42 35 8-12-14 6-8-13	55 47 10-13-17 8-10-14	70 58 12-14-19 10-12-16	84 70 13-16-21 10-13-17	98 82 13-17-22 12-13-18	112 94 14-18-23 12-14-19	126 105 16-19-25 13-16-21							
	2A 2B	CFM/SIDE THROW, FT.	56 11-12-16	75 12-14-19	93 13-16-22	112 14-18-23	131 16-19-24	150 17-20-26	168 18-22-29							
	2C 2E	CFM/SIDE THROW, FT.	75 37 12-14-19 8-12-14	100 50 13-16-22 10-13-17	125 62 14-18-25 12-14-19	150 75 16-19-29 13-16-21	175 87 17-21-29 13-17-25	200 100 18-22-31 14-18-23	225 112 20-23-33 16-20-25							
1A 1B	CFM/SIDE THROW, FT.	112 14-17-23	150 17-19-29	187 19-22-31	225 21-23-34	262 22-25-36	300 23-29-39	337 25-29-42								
12 x 6 .50 SQ. FT.	RETURN FACTORS —SP=1.6 TP NC + 1	CFM NC	150 —	—	200 14	—	250 20	—	300 26	—	350 31	—	400 35	—	450 39	—
	4B	CFM/SIDE THROW, FT.	56 18 11-13-17 5-6-10	75 25 12-14-19 6-7-11	94 31 13-17-22 7-10-12	113 37 14-18-23 7-10-13	131 44 16-19-26 10-11-14	150 50 17-20-26 10-11-14	169 56 18-22-29 11-12-16							
	3A1	CFM/SIDE THROW, FT.	66 18 11-13-18 5-6-10	87 25 12-14-20 6-7-11	109 31 13-17-23 7-10-12	131 37 14-18-26 7-10-13	153 44 16-19-26 10-11-14	175 50 17-20-29 10-11-14	197 56 18-22-30 11-12-16							
	3B	CFM/SIDE THROW, FT.	75 37 11-16-20 8-12-14	100 50 14-18-23 10-13-17	126 62 16-20-27 12-14-19	150 75 18-22-29 13-16-21	176 87 18-23-31 13-17-25	200 100 20-25-32 14-18-23	226 112 22-27-34 16-20-25							
	2A 2B	CFM/SIDE THROW, FT.	75 11-13-18	100 12-14-20	125 13-17-23	150 14-18-26	175 16-19-26	200 17-20-29	225 18-22-30							
	2C 2E	CFM/SIDE THROW, FT.	112 37 14-17-23 8-12-14	150 50 17-19-29 10-13-17	188 62 19-22-31 12-14-19	225 75 21-23-34 13-16-21	263 87 22-25-36 13-17-25	300 100 23-29-39 14-18-23	338 112 25-29-42 16-20-25							
1A 1B	CFM/SIDE THROW, FT.	150 14-17-23	200 17-19-29	250 19-22-31	300 21-23-34	350 22-25-36	400 23-29-39	450 25-29-42								
15 x 6 .625 SQ. FT.	RETURN FACTORS —SP=1.9 TP NC + 1	CFM NC	190 —	—	250 15	—	310 21	—	375 27	—	440 32	—	500 36	—	565 40	—
	4B	CFM/SIDE THROW, FT.	75 18 11-13-18 5-6-10	100 25 12-14-20 6-7-11	125 31 13-17-23 7-10-12	150 37 14-18-26 7-10-13	175 44 16-19-26 10-11-14	200 50 17-20-29 10-11-14	225 56 18-22-30 11-12-16							
	4E	CFM/SIDE THROW, FT.	56 37 11-12-16 10-11-14	75 50 12-14-19 11-12-17	94 62 12-17-22 12-13-19	113 75 14-18-23 13-14-20	131 87 16-19-26 14-16-22	150 100 16-20-26 14-17-23	169 112 18-22-29 16-18-26							
	3A1	CFM/SIDE THROW, FT.	84 18 12-13-19 5-6-10	112 25 13-16-22 6-7-11	140 31 14-18-24 7-10-12	169 37 16-19-26 7-10-13	197 44 17-20-28 10-11-14	225 50 18-22-30 10-11-14	253 56 19-23-34 11-12-16							
	2A 2B	CFM/SIDE THROW, FT.	94 12-14-20	125 13-16-23	156 14-19-26	187 16-20-28	219 17-22-30	250 18-23-31	281 19-26-35							
	2C 2E	CFM/SIDE THROW, FT.	150 37 14-17-23 8-12-14	200 50 17-19-29 10-13-17	250 62 19-22-31 12-14-19	300 75 21-23-34 13-16-21	350 87 22-25-36 13-17-22	400 100 23-29-39 14-18-23	450 112 25-29-42 16-20-25							
1A 1B	CFM/SIDE THROW, FT.	188 16-19-26	250 18-22-30	312 21-25-34	375 22-29-38	438 23-29-40	500 25-31-43	563 29-32-45								

Notes:

1. Core style 4E is sized to give equal flow as near as possible in directions A and B.
2. For core styles 1A, 1B, 2A and 2B, the "A" direction is shown. Throw correction factor for "B" direction is: A x .82 = B.

For performance notes, see page D37.

D
CEILING DIFFUSERS

PERFORMANCE DATA:

MODELS 6500 AND 6200 • RECTANGULAR NECK

NOMINAL NECK SIZE	BLOW PATTERNS	NECK VELOCITY TP	300 .033		400 .058		500 .090		600 .130		700 .177		800 .231		900 .293		
			CFM NC	—	A	B	A	B	A	B	A	B	A	B	A	B	A
18 x 6 .75 SQ. FT.	RETURN FACTORS —SP=2.6 TP NC + 2	CFM NC	225 —		300 16		375 22		450 28		525 33		600 37		675 41		
	4B 4C	CFM/SIDE THROW, FT.	94 18	125 25	156 31	188 37	218 44	250 50	281 56								
	4E	CFM/SIDE THROW, FT.	56 56	75 75	94 94	113 113	131 131	150 150	169 169								
	3A1	CFM/SIDE THROW, FT.	103 18	137 25	172 31	206 37	240 44	275 50	309 56								
	2A 2B	CFM/SIDE THROW, FT.	112	150	187	225	262	300	337								
	2C 2D 2E 2F	CFM/SIDE THROW, FT.	187 37	250 50	313 62	375 75	438 87	500 100	563 112								
	1A 1B	CFM/SIDE THROW, FT.	225	300	375	450	525	600	675								
21 x 6 .875 SQ. FT.	RETURN FACTORS —SP=3.2 TP NC + 3	CFM NC	260 —		350 16		435 22		525 29		610 33		700 38		785 41		
	4B 4C	CFM/SIDE THROW, FT.	112 18	150 25	187 31	225 37	262 44	300 50	337 56								
	4E	CFM/SIDE THROW, FT.	75 56	100 75	125 94	150 113	175 131	200 150	225 169								
	3A1	CFM/SIDE THROW, FT.	122 18	162 25	203 31	244 37	284 44	325 50	365 56								
	2A 2B	CFM/SIDE THROW, FT.	131	175	218	262	306	350	393								
	2C 2D 2E 2F	CFM/SIDE THROW, FT.	225 37	300 50	375 62	450 75	525 87	600 100	675 112								
	1A 1B	CFM/SIDE THROW, FT.	262	350	437	525	612	700	787								
24 x 6 1.0 SQ. FT.	RETURN FACTORS —SP=3.9 TP NC + 4	CFM NC	300 —		400 16		500 23		600 30		700 34		800 39		900 42		
	4B 4C	CFM/SIDE THROW, FT.	131 18	175 25	219 31	263 37	306 44	350 50	394 56								
	4E	CFM/SIDE THROW, FT.	75 75	100 100	125 125	150 150	175 175	200 200	225 225								
	3A1	CFM/SIDE THROW, FT.	141 18	187 25	234 31	281 37	328 44	375 50	422 56								
	2A 2B	CFM/SIDE THROW, FT.	150	200	250	300	350	400	450								
	2C 2D 2E 2F	CFM/SIDE THROW, FT.	260 37	350 50	438 62	525 75	613 87	700 100	788 112								
	1A 1B	CFM/SIDE THROW, FT.	300	400	500	600	700	800	900								

Notes:

1. Core style 4E is sized to give equal flow as near as possible in directions A and B.
2. For core styles 1A, 1B, 2A and 2B, the "A" direction is shown. Throw correction factor for "B" direction is: A x .82 = B.

For performance notes, see page D37.

PERFORMANCE DATA:

MODELS 6500 AND 6200 • RECTANGULAR NECK

NOMINAL NECK SIZE	BLOW PATTERNS	NECK VELOCITY TP	300 .033		400 .058		500 .090		600 .130		700 .177		800 .231		900 .293	
			CFM NC	A	B	A	B	A	B	A	B	A	B	A	B	A
30 x 6 1.25 SQ. FT.	RETURN FACTORS —SP=3.2 TP NC + 3	CFM NC	375 —		500 17		625 24		750 30		875 35		1000 40		1125 43	
	4B 4C	CFM/SIDE THROW, FT.	169	18	225	25	281	31	338	37	393	44	450	50	506	56
	4E	CFM/SIDE THROW, FT.	94	94	125	125	156	156	188	188	219	219	250	250	282	282
	3A1	CFM/SIDE THROW, FT.	178	18	237	25	297	31	356	37	415	44	475	50	534	56
	2A 2B	CFM/SIDE THROW, FT.	187		250		312		375		437		500		562	
	2C 2D 2E 2F	CFM/SIDE THROW, FT.	337	37	450	50	563	62	675	75	788	87	900	100	1013	112
1A 1B	CFM/SIDE THROW, FT.	375		500		625		750		875		1000		1125		
12 x 9 .75 SQ. FT.	RETURN FACTORS —SP=3.9 TP NC + 4	CFM NC	225 —		300 17		375 23		450 28		525 33		600 36		675 40	
	4B 4C	CFM/SIDE THROW, FT.	70	42	94	56	117	70	141	84	164	98	188	112	211	126
	3A1	CFM/SIDE THROW, FT.	91	42	121	56	152	70	183	84	213	98	244	112	274	126
	3A2	CFM/SIDE THROW, FT.	75	75	100	100	125	125	150	150	175	175	200	200	225	225
	2A 2B	CFM/SIDE THROW, FT.	112		150		187		225		262		300		337	
	2C 2D 2E 2F	CFM/SIDE THROW, FT.	141	84	188	112	234	141	281	169	328	197	375	225	422	253
1A 1B	CFM/SIDE THROW, FT.	225		300		375		450		525		600		675		
15 x 9 .93 SQ. FT.	RETURN FACTORS —SP=1.7 TP NC + 3	CFM NC	280 —		375 18		470 24		565 29		655 34		750 37		845 41	
	4B 4C	CFM/SIDE THROW, FT.	98	42	131	56	165	70	198	84	230	98	263	112	296	126
	4E	CFM/SIDE THROW, FT.	70	70	94	94	117	117	141	141	164	164	188	188	211	211
	3A1	CFM/SIDE THROW, FT.	120	42	159	56	200	70	240	84	279	98	319	112	359	126
	3A2	CFM/SIDE THROW, FT.	117	82	155	110	196	137	233	165	272	192	312	219	351	247
	2A 2B	CFM/SIDE THROW, FT.	140		187		235		281		328		375		422	
2C 2D 2E 2F	CFM/SIDE THROW, FT.	197	84	263	112	329	141	394	169	459	197	525	225	592	253	
1A 1B	CFM/SIDE THROW, FT.	281		375		470		563		656		750		845		

Notes:

1. Core style 4E is sized to give equal flow as near as possible in directions A and B.
2. For core styles 1A, 1B, 2A and 2B, the "A" direction is shown. Throw correction factor for "B" direction is: $A \times .82 = B$.

For performance notes, see page D37.

D
CEILING DIFFUSERS

PERFORMANCE DATA:

MODELS 6500 AND 6200 • RECTANGULAR NECK

NOMINAL NECK SIZE	BLOW PATTERNS	NECK VELOCITY TP	300 .033		400 .058		500 .090		600 .130		700 .177		800 .231		900 .293	
			CFM NC	A	B	A	B	A	B	A	B	A	B	A	B	A
18 x 9 1.125 SQ. FT.	RETURN FACTORS —SP=2.1 TP NC + 3	CFM NC	335		450		560		675		790		900		1010	
	4B 4C	CFM/SIDE THROW, FT.	126	42	169	56	211	70	254	84	296	98	338	112	380	126
	4E	CFM/SIDE THROW, FT.	99	70	132	94	164	117	197	141	230	164	263	188	296	211
	3A1	CFM/SIDE THROW, FT.	147	42	197	56	246	70	295	84	345	98	394	112	443	126
	3B	CFM/SIDE THROW, FT.	168	84	225	112	281	141	337	169	394	197	450	225	506	253
	2A 2B	CFM/SIDE THROW, FT.	163		225		281		337		394		450		506	
	2C 2E 2D 2F	CFM/SIDE THROW, FT.	253	84	338	112	421	141	506	169	591	197	675	225	759	253
1A 1B	CFM/SIDE THROW, FT.	337		450		562		675		788		900		1012		
21 x 9 1.125 SQ. FT.	RETURN FACTORS —SP=2.5 TP NC + 4	CFM NC	395		525		655		785		915		1050		1180	
	4B 4C	CFM/SIDE THROW, FT.	154	42	206	56	258	70	309	84	360	98	413	112	464	126
	4E	CFM/SIDE THROW, FT.	98	98	131	131	163	163	196	196	229	229	261	261	294	294
	3A1	CFM/SIDE THROW, FT.	175	42	234	56	292	70	351	84	410	98	468	112	527	126
	2A 2B	CFM/SIDE THROW, FT.	196		262		327		393		458		525		590	
	2C 2E 2D 2F	CFM/SIDE THROW, FT.	308	84	412	112	514	141	617	169	720	197	825	225	927	253
	1A 1B	CFM/SIDE THROW, FT.	393		524		655		786		917		1050		1180	
24 x 9 1.5 SQ. FT.	RETURN FACTORS —SP=2.9 TP NC + 4	CFM NC	450		600		750		900		1050		1200		1350	
	4B 4C	CFM/SIDE THROW, FT.	183	42	244	56	305	70	366	84	427	98	488	112	549	126
	4E	CFM/SIDE THROW, FT.	126	99	169	132	211	164	253	197	295	230	337	263	379	296
	3A1	CFM/SIDE THROW, FT.	204	42	272	56	340	70	408	84	476	98	544	112	612	126
	2A 2B	CFM/SIDE THROW, FT.	225		300		375		450		525		600		675	
	2C 2E 2D 2F	CFM/SIDE THROW, FT.	365	84	488	112	609	141	731	169	853	197	975	225	1097	253
	1A 1B	CFM/SIDE THROW, FT.	450		600		750		900		1050		1200		1350	

Notes:

1. Core style 4E is sized to give equal flow as near as possible in directions A and B.
2. For core styles 1A, 1B, 2A and 2B, the "A" direction is shown. Throw correction factor for "B" direction is: $A \times .82 = B$.

For performance notes, see page D37.

PERFORMANCE DATA:

MODELS 6500 AND 6200 • RECTANGULAR NECK

NOMINAL NECK SIZE	BLOW PATTERNS	NECK VELOCITY TP	300 .033		400 .058		500 .090		600 .130		700 .177		800 .231		900 .293	
			CFM NC	A	B	A	B	A	B	A	B	A	B	A	B	A
30 x 9 1.875 SQ. FT.	RETURN FACTORS —SP=3.9 TP NC + 5	CFM NC	560 —		750 20		935 26		1125 32		1310 37		1500 39		1685 44	
	4B 4C	CFM/SIDE THROW, FT.	238	42	319	56	398	70	478	84	557	98	638	112	716	126
	4E	CFM/SIDE THROW, FT.	155	126	206	169	258	211	310	253	361	295	413	337	465	379
	3A1	CFM/SIDE THROW, FT.	259	42	347	56	433	70	520	84	606	98	694	112	779	126
	2A 2B	CFM/SIDE THROW, FT.	281		375		468		562		655		750		842	
	2C 2E	CFM/SIDE THROW, FT.	476	84	638	112	796	141	956	169	1113	197	1275	225	1432	253
	1A 1B	CFM/SIDE THROW, FT.	562		750		937		1125		1310		1500		1685	
36 x 9 2.25 SQ. FT.	RETURN FACTORS —SP=5.0 TP NC + 6	CFM NC	675 —		900 21		1125 27		1350 33		1575 38		1800 40		2025 44	
	4B 4C	CFM/SIDE THROW, FT.	295	42	394	56	492	70	591	84	689	98	788	112	886	126
	4E	CFM/SIDE THROW, FT.	183	155	244	206	305	258	366	310	427	361	488	413	549	465
	3A1	CFM/SIDE THROW, FT.	316	42	422	56	527	70	633	84	738	98	844	112	949	126
	2A 2B	CFM/SIDE THROW, FT.	337		450		562		675		787		900		1012	
	2C 2E	CFM/SIDE THROW, FT.	590	84	788	112	984	141	1181	169	1378	197	1575	225	1772	253
	1A 1B	CFM/SIDE THROW, FT.	675		900		1125		1350		1575		1800		2025	
15 x 12 1.25 SQ. FT.	RETURN FACTORS —SP=1.6 TP NC + 2	CFM NC	375 —		500 19		625 25		750 30		875 34		1000 38		1125 41	
	4B 4C	CFM/SIDE THROW, FT.	112	75	150	100	187	125	225	150	262	175	300	200	337	225
	3A1	CFM/SIDE THROW, FT.	150	75	200	100	250	125	300	150	350	175	400	200	450	225
	3A2	CFM/SIDE THROW, FT.	117	129	156	172	195	215	234	258	273	301	312	344	351	387
	2A 2B	CFM/SIDE THROW, FT.	187		250		312		375		437		500		567	
	2C 2E	CFM/SIDE THROW, FT.	225	150	300	200	375	250	450	300	525	350	600	400	675	450
	1A 1B	CFM/SIDE THROW, FT.	375		500		625		750		875		1000		1125	

Notes:

1. Core style 4E is sized to give equal flow as near as possible in directions A and B.
2. For core styles 1A, 1B, 2A and 2B, the "A" direction is shown. Throw correction factor for "B" direction is: $A \times .82 = B$.

For performance notes, see page D37.

D
CEILING DIFFUSERS

PERFORMANCE DATA:

MODELS 6500 AND 6200 • RECTANGULAR NECK

NOMINAL NECK SIZE	BLOW PATTERNS	NECK VELOCITY TP	300 .033	400 .058	500 .090	600 .130	700 .177	800 .231	900 .293	
18 x 12 1.5 SQ. FT.	RETURN FACTORS —SP=1.9 TP NC + 3	CFM NC	450 —	600 20	750 26	900 31	1050 35	1200 39	1350 42	
			A B	A B	A B	A B	A B	A B	A B	
			CFM/SIDE THROW, FT.	150 75 15-18-25 8-13-15	200 100 18-21-31 11-14-18	250 125 21-24-34 13-15-21	300 150 22-25-36 14-17-22	350 175 24-27-39 14-18-24	400 200 25-31-42 15-20-25	450 225 27-31-45 17-21-27
		CFM/SIDE THROW, FT.	187 75 17-21-28 8-13-15	250 100 20-24-32 11-14-18	312 125 22-27-36 13-15-21	375 150 24-31-41 14-17-22	437 175 25-31-43 14-18-24	500 200 27-34-46 15-20-25	562 225 31-35-49 17-21-27	
		CFM/SIDE THROW, FT.	168 141 14-17-24 13-15-21	225 187 15-20-27 14-17-24	281 234 17-22-31 15-20-27	337 281 18-24-32 17-21-31	394 328 20-25-35 18-22-31	450 375 21-27-36 20-24-34	506 422 22-31-41 21-25-35	
		CFM/SIDE THROW, FT.	225 18-22-31	300 21-25-35	375 24-28-41	450 25-31-45	525 27-32-48	600 29-35-50	675 31-39-53	
			CFM/SIDE THROW, FT.	300 150 20-24-34 14-17-24	400 200 22-27-39 15-20-27	500 250 25-31-45 17-22-31	600 300 27-32-48 18-24-32	700 350 29-35-50 20-25-35	800 400 31-36-55 21-27-36	900 450 34-41-57 22-31-41
	CFM/SIDE THROW, FT.	450 21-25-35	600 24-31-42	750 27-34-48	900 29-36-50	1050 31-39-55	1200 34-42-59	1350 35-45-62		
21 x 12 1.75 SQ. FT.	RETURN FACTORS —SP=2.2 TP NC + 5	CFM NC	525 —	700 20	875 26	1050 31	1225 35	1400 39	1575 42	
			A B	A B	A B	A B	A B	A B	A B	
			CFM/SIDE THROW, FT.	187 75 17-21-28 8-13-15	250 100 20-24-32 11-14-18	312 125 22-27-36 13-15-21	375 150 24-31-41 14-17-22	437 175 25-32-43 14-18-24	500 200 27-34-46 15-20-25	562 225 31-35-49 17-21-27
		CFM/SIDE THROW, FT.	150 112 15-18-25	200 150 18-21-31 15-18-25	250 187 21-24-34	300 225 22-25-36	350 262 24-27-39	400 300 25-31-42 22-25-36	450 337 27-31-45	
		CFM/SIDE THROW, FT.	225 75 18-22-31 8-13-15	300 100 21-25-35 11-14-18	375 125 24-28-41 13-15-21	450 150 25-31-45 14-17-22	525 175 27-32-48 14-18-24	600 200 29-35-50 15-20-25	675 225 31-39-53 17-21-27	
		CFM/SIDE THROW, FT.	230 148 14-17-24 13-15-21	306 197 15-20-27 14-17-24	382 246 17-22-31 15-20-27	460 295 18-24-32 17-21-31	535 345 20-25-35 18-22-31	612 394 21-27-36 20-24-34	688 443 22-31-41 21-25-35	
		CFM/SIDE THROW, FT.	262 18-22-31	350 21-25-35	437 24-28-41	525 25-31-45	612 27-32-48	700 29-35-50	787 31-39-53	
		CFM/SIDE THROW, FT.	375 150 21-25-35 14-17-24	500 200 24-31-42 15-20-27	625 250 27-34-48 17-22-31	750 300 29-36-50 18-24-32	875 350 31-39-55 20-25-35	1000 400 34-42-59 21-27-36	1125 450 35-45-62 22-31-41	
	CFM/SIDE THROW, FT.	525 22-27-39	700 25-31-45	875 28-35-50	1050 31-39-55	1225 32-42-59	1400 35-45-62	1575 39-48-66		
24 x 12 2.0 SQ. FT.	RETURN FACTORS —SP=2.6 TP NC + 5	CFM NC	600 12	800 21	1000 27	1200 32	1400 36	1600 40	1800 43	
			A B	A B	A B	A B	A B	A B	A B	
			CFM/SIDE THROW, FT.	225 75 18-22-31 8-13-15	300 100 21-25-35 11-14-18	375 125 24-28-41 13-15-21	450 150 25-31-45 14-17-22	525 175 27-32-48 14-18-24	600 200 31-35-50 15-20-25	675 225 31-39-53 17-21-27
		CFM/SIDE THROW, FT.	150 150 15-18-25 15-18-25	200 200 18-21-31 18-21-31	250 250 21-24-34 21-24-34	300 300 22-25-36 22-25-36	350 350 24-27-39 24-27-39	400 400 25-31-42 25-31-42	450 450 27-31-45 27-31-45	
		CFM/SIDE THROW, FT.	262 75 18-22-31 8-13-15	350 100 21-25-35 11-14-18	437 175 24-28-41 13-15-21	525 150 25-31-45 14-17-22	612 175 27-32-48 14-18-24	700 200 29-35-50 15-20-25	787 225 31-39-53 17-21-27	
		CFM/SIDE THROW, FT.	300 150 15-18-25 14-17-24	400 200 18-21-31 15-20-27	500 250 21-24-34 17-22-31	600 300 22-25-36 18-24-32	700 350 24-27-39 20-25-35	800 400 25-31-42 21-27-36	900 450 27-31-45 22-31-41	
		CFM/SIDE THROW, FT.	300 20-24-34	400 22-27-39	500 25-31-45	600 27-32-48	700 29-35-50	800 31-36-55	900 34-41-57	
		CFM/SIDE THROW, FT.	450 150 21-25-35 14-17-24	600 200 24-31-42 15-20-27	750 250 27-34-48 17-22-31	900 300 29-36-50 18-24-32	1050 350 31-39-55 20-25-35	1200 400 34-42-59 21-27-36	1350 450 35-45-62 22-31-41	
	CFM/SIDE THROW, FT.	600 24-31-42	800 28-34-48	1000 32-39-55	1200 34-42-57	1400 36-45-62	1600 41-49-66	1800 43-52-70		

Notes:

1. Core style 4E is sized to give equal flow as near as possible in directions A and B.
2. For core styles 1A, 1B, 2A and 2B, the "A" direction is shown. Throw correction factor for "B" direction is: A x .82 = B.

For performance notes, see page D37.

PERFORMANCE DATA:

MODELS 6500 AND 6200 • RECTANGULAR NECK

NOMINAL NECK SIZE	BLOW PATTERNS	NECK VELOCITY TP	300 .033		400 .058		500 .090		600 .130		700 .177		800 .231		900 .293		
			CFM NC	300 15	400 23	500 29	600 33	700 37	800 41	900 43	A	B	A	B	A	B	A
30 x 12 2.5 SQ. FT.	RETURN FACTORS —SP=3.3 TP NC + 6	CFM NC	750 15	1000 23	1250 29	1500 33	1750 37	2000 41	2250 43								
	4B 4C	CFM/SIDE THROW, FT.	300 75 20-24-34 8-13-15	400 100 22-27-39 11-14-18	500 125 25-31-45 13-15-21	600 150 27-32-48 14-17-22	700 175 29-35-50 14-18-24	800 200 31-36-55 15-20-25	900 225 34-41-57 17-21-27								
	4E	CFM/SIDE THROW, FT.	183 183 17-21-28 17-21-28	250 250 20-24-32 20-24-32	313 313 22-27-36 22-27-36	375 375 24-31-41 24-31-41	437 437 25-31-43 25-31-43	500 500 27-34-46 27-34-46	562 562 31-35-49 31-35-49								
	3A1	CFM/SIDE THROW, FT.	337 75 20-24-34 8-13-15	450 100 22-27-39 11-14-18	562 125 25-31-45 13-15-21	675 150 27-32-48 14-17-22	787 175 29-35-50 14-18-24	900 200 31-36-55 15-20-25	1012 225 34-41-57 17-21-27								
	2A 2B	CFM/SIDE THROW, FT.	375 21-25-35	500 24-31-42	625 27-34-48	750 29-36-50	875 31-39-55	1000 34-42-59	1125 35-45-62								
	2C 2D 2E 2F	CFM/SIDE THROW, FT.	600 150 24-31-41 14-17-24	800 200 28-34-48 15-20-27	1000 250 32-39-55 17-22-31	1200 300 34-42-57 18-24-32	1400 350 36-45-62 20-25-35	1600 400 41-49-66 21-27-36	1800 450 43-52-70 22-31-41								
1A 1B	CFM/SIDE THROW, FT.	750 25-31-45	1000 31-35-50	1250 34-41-57	1500 36-45-62	1750 39-48-66	2000 42-50-70	2250 45-53-74									
36 x 12 3.0 SQ. FT.	RETURN FACTORS —SP=4.0 TP NC + 7	CFM NC	900 16	1200 25	1500 30	1800 34	2100 38	2400 42	2700 44								
	4B 4C	CFM/SIDE THROW, FT.	375 75 21-25-35 8-13-15	500 100 24-31-42 11-14-18	625 125 27-34-48 13-15-21	750 150 29-36-50 14-17-22	875 175 31-39-55 14-18-24	1000 200 34-42-59 15-20-25	1125 225 35-45-62 17-21-27								
	4E	CFM/SIDE THROW, FT.	225 225 18-22-31 18-22-31	300 300 21-25-35 21-25-35	375 375 24-28-41 24-28-41	450 450 25-31-45 25-31-45	525 525 27-32-48 27-32-48	600 600 29-35-50 29-35-50	675 675 31-39-53 31-39-53								
	3A1	CFM/SIDE THROW, FT.	412 75 21-25-35 8-13-15	550 100 24-31-42 11-14-18	687 125 27-34-48 13-15-21	825 150 29-36-50 14-17-22	962 175 31-39-55 14-18-24	1100 200 34-42-59 15-20-25	1237 225 35-45-62 17-21-27								
	2A 2B	CFM/SIDE THROW, FT.	450 21-25-35	600 24-31-42	750 27-34-48	900 29-36-50	1050 31-39-55	1200 34-42-59	1350 35-45-62								
	2C 2D 2E 2F	CFM/SIDE THROW, FT.	750 150 25-31-45 14-17-24	1000 200 31-35-50 15-20-27	1250 250 34-41-57 17-22-31	1500 300 36-45-62 18-24-32	1750 350 39-48-66 20-25-35	2000 400 42-50-70 21-27-36	2250 450 45-53-74 22-31-41								
1A 1B	CFM/SIDE THROW, FT.	900 27-34-46	1200 31-39-53	1500 35-45-60	1800 39-48-64	2100 42-50-70	2400 45-55-74	2700 48-57-80									
18 x 15 1.875 SQ. FT.	RETURN FACTORS —SP=2.0 TP NC + 4	CFM NC	560 14	750 21	935 28	1125 32	1310 36	1500 39	1685 43								
	4B 4C	CFM/SIDE THROW, FT.	164 117 14-17-24 11-14-18	219 156 15-20-27 13-15-21	273 195 17-22-31 14-17-24	328 234 18-24-32 15-18-25	383 273 20-25-35 17-20-27	438 312 21-27-36 17-21-31	492 351 22-31-41 18-22-31								
	3A1	CFM/SIDE THROW, FT.	222 117 18-22-31 11-14-18	297 156 21-25-35 13-15-21	371 195 24-28-41 14-17-24	445 234 25-31-45 15-18-25	519 273 31-39-55 17-20-27	594 312 31-35-50 17-21-31	668 351 31-39-53 18-22-31								
	3A2	CFM/SIDE THROW, FT.	168 197 13-16-22 18-22-30	225 262 15-18-25 21-25-34	281 328 16-21-28 24-28-39	337 394 18-22-33 25-33-43	394 459 19-24-33 27-33-46	450 525 21-25-36 28-36-49	506 590 22-27-37 33-37-52								
	2A 2B	CFM/SIDE THROW, FT.	281 20-24-34	375 22-27-39	468 25-31-45	562 27-32-48	656 29-35-50	750 31-36-55	843 34-41-57								
	2C 2D 2E 2F	CFM/SIDE THROW, FT.	329 234 25-33-45 18-22-30	438 312 30-36-51 21-25-34	547 390 34-42-58 24-28-39	657 468 36-45-61 25-31-43	766 546 39-48-66 27-33-46	876 624 43-52-70 28-36-49	985 702 46-55-75 33-37-52								
1A 1B	CFM/SIDE THROW, FT.	562 24-28-42	750 27-33-48	937 30-37-54	1125 33-42-58	1312 34-45-63	1500 37-48-66	1687 42-51-70									

Notes:

1. Core style 4E is sized to give equal flow as near as possible in directions A and B.
2. For core styles 1A, 1B, 2A and 2B, the "A" direction is shown. Throw correction factor for "B" direction is: A x .82 = B.

For performance notes, see page D37.

PERFORMANCE DATA:

MODELS 6500 AND 6200 • RECTANGULAR NECK

NOMINAL NECK SIZE	BLOW PATTERNS	NECK VELOCITY TP	300 .033		400 .058		500 .090		600 .130		700 .177		800 .231		900 .293	
			CFM NC	655 14	875 21	1090 28	1310 33	1530 36	1750 39	1970 43	A	B	A	B	A	B
21 x 15 SQ. FT.	RETURN FACTORS —SP=2.1 TP NC + 5	CFM NC	655 14	875 21	1090 28	1310 33	1530 36	1750 39	1970 43							
	4B 4C	CFM/SIDE THROW, FT.	210 117	281 156	361 195	422 234	493 273	563 312	634 351							
	4E	CFM/SIDE THROW, FT.	164 164	218 218	273 273	327 327	382 382	437 437	491 491							
	3A1	CFM/SIDE THROW, FT.	269 117	359 156	448 195	539 234	629 273	719 312	809 351							
	3A2	CFM/SIDE THROW, FT.	230 213	306 284	382 355	460 426	535 498	612 569	688 641							
	2A 2B	CFM/SIDE THROW, FT.	327	437	596	656	766	875	985							
	2C 2D 2E	CFM/SIDE THROW, FT.	422 234	563 312	702 390	844 468	966 546	1126 624	1268 702							
	1A 1B	CFM/SIDE THROW, FT.	655	875	1092	1312	1532	1750	1970							
24 x 15 SQ. FT.	RETURN FACTORS —SP=2.6 TP NC + 6	CFM NC	750 14	1000 22	1250 29	1500 34	1750 37	2000 39	2250 44							
	4B 4C	CFM/SIDE THROW, FT.	258 117	344 156	430 195	516 234	602 273	688 312	774 351							
	4E	CFM/SIDE THROW, FT.	164 211	218 281	273 352	327 422	382 492	437 563	491 633							
	3A1	CFM/SIDE THROW, FT.	316 117	422 156	527 195	633 234	738 273	844 312	949 351							
	3A2	CFM/SIDE THROW, FT.	300 225	400 300	500 375	600 450	700 525	800 600	900 675							
	2A 2B	CFM/SIDE THROW, FT.	375	500	625	750	875	1000	1125							
	2C 2D 2E	CFM/SIDE THROW, FT.	516 234	688 312	860 390	1032 468	1204 546	1376 624	1548 702							
	1A 1B	CFM/SIDE THROW, FT.	750	1000	1250	1500	1750	2000	2250							
30 x 15 SQ. FT.	RETURN FACTORS —SP=3.1 TP NC + 7	CFM NC	935 14	1250 23	1565 30	1875 36	2190 39	2500 40	2810 45							
	4B 4C	CFM/SIDE THROW, FT.	351 117	469 156	587 195	703 234	822 273	938 312	1054 351							
	4E	CFM/SIDE THROW, FT.	258 211	344 281	430 352	516 422	602 492	688 583	775 633							
	3A1	CFM/SIDE THROW, FT.	410 117	547 156	685 195	820 234	958 273	1094 312	1224 351							
	3B	CFM/SIDE THROW, FT.	468 234	625 312	782 391	937 469	1095 547	1250 625	1406 702							
	2A 2B	CFM/SIDE THROW, FT.	468	625	782	937	1095	1250	1405							
	2C 2D 2E	CFM/SIDE THROW, FT.	702 234	938 312	1175 390	1407 468	1644 546	1876 624	2108 702							
	1A 1B	CFM/SIDE THROW, FT.	937	1250	1565	1875	2190	2500	2810							

Notes:

1. Core style 4E is sized to give equal flow as near as possible in directions A and B.
2. For core styles 1A, 1B, 2A and 2B, the "A" direction is shown. Throw correction factor for "B" direction is: $A \times .82 = B$.

For performance notes, see page D37.

PERFORMANCE DATA:

MODELS 6500 AND 6200 • RECTANGULAR NECK

NOMINAL NECK SIZE	BLOW PATTERNS	NECK VELOCITY TP	300 .033		400 .058		500 .090		600 .130		700 .177		800 .231		900 .293		
			CFM NC	THROW, FT.	A	B	A	B	A	B	A	B	A	B	A	B	A
36 x 15 3.75 SQ. FT.	RETURN FACTORS —SP=3.8 TP NC + 7	CFM NC	1125 13	1500 23	1875 31	2250 37	2625 40	3000 41	3375 46								
	4B 4C	CFM/SIDE THROW, FT.	446 117 22-27-37 12-15-19	594 156 25-33-45 13-16-22	742 195 28-36-51 15-18-25	891 234 33-39-54 16-19-27	1039 273 33-45-58 18-21-28	1188 312 36-45-63 18-22-30	1336 351 37-48-66 19-24-33								
	4E	CFM/SIDE THROW, FT.	306 258 21-25-36 19-24-33	408 344 24-28-42 22-27-37	510 430 27-33-48 25-30-43	612 516 28-34-51 27-33-48	714 602 33-37-54 28-34-51	816 688 33-39-58 33-37-54	918 775 36-43-61 33-42-57								
	3A1	CFM/SIDE THROW, FT.	504 117 24-28-42 12-15-19	672 156 27-33-48 13-16-22	840 195 30-37-54 15-18-25	1008 234 33-45-58 16-19-27	1176 273 34-45-63 18-21-28	1344 312 37-48-66 18-22-30	1512 351 42-51-70 19-24-33								
	2A 2B	CFM/SIDE THROW, FT.	562 24-28-42	750 27-33-48	937 30-37-54	1125 33-42-58	1312 34-45-63	1500 37-48-66	1682 42-51-70								
	2C 2E 2D 2F	CFM/SIDE THROW, FT.	890 234 28-36-49 18-22-30	1188 312 33-42-49 21-25-34	1485 390 37-48-64 24-28-39	1782 468 42-51-69 25-33-43	2079 546 45-54-75 27-33-46	2376 624 48-58-79 28-36-49	2873 702 51-61-85 33-37-52								
1A 1B	CFM/SIDE THROW, FT.	1125 30-37-52	1500 34-43-60	1875 39-48-67	2250 42-52-73	2625 46-57-78	3000 49-60-85	3375 52-64-90									
21 x 18 2.625 SQ. FT.	RETURN FACTORS —SP=2.2 TP NC + 5	CFM NC	785 14	1050 21	1310 27	1575 32	1840 36	2100 40	2360 43								
	4B 4C	CFM/SIDE THROW, FT.	225 169 16-19-27 13-16-22	300 225 19-22-33 15-18-25	375 280 22-25-36 16-21-28	450 337 24-27-40 18-22-30	526 394 25-28-42 19-24-33	600 450 27-33-45 21-25-36	674 506 28-33-48 22-27-37								
	3A1	CFM/SIDE THROW, FT.	309 169 21-25-36 13-16-22	412 225 24-28-42 15-18-25	514 281 27-33-48 16-21-28	619 337 28-34-51 18-22-30	723 394 33-37-54 19-24-33	825 450 33-39-58 21-25-36	927 506 36-43-61 22-27-37								
	3A2	CFM/SIDE THROW, FT.	279 230 21-25-36 15-18-25	372 306 24-28-42 16-21-28	464 382 27-33-48 18-24-33	557 460 28-34-51 19-25-34	652 535 33-37-54 21-27-37	744 612 33-39-58 22-28-39	836 688 36-43-61 24-33-43								
	2A 2B	CFM/SIDE THROW, FT.	393 22-27-37	525 25-33-42	655 28-36-46	787 30-39-54	920 33-42-58	1050 36-45-63	1180 37-48-66								
	2C 2E 2D 2F	CFM/SIDE THROW, FT.	450 338 22-27-37 19-24-33	600 450 25-33-42 22-27-37	750 560 28-36-46 25-30-43	900 675 30-39-54 27-33-48	1060 790 33-42-58 28-34-51	1200 900 36-45-63 33-37-54	1350 1010 37-48-66 33-42-57								
1A 1B	CFM/SIDE THROW, FT.	787 29-35-51	1050 35-40-58	1310 38-46-66	1575 42-51-70	1840 45-54-75	2100 48-58-80	2360 51-61-85									
24 x 18 3.0 SQ. FT.	RETURN FACTORS —SP=2.5 TP NC + 6	CFM NC	900 15	1200 22	1500 28	1800 33	2100 37	2400 40	2700 43								
	4B 4C	CFM/SIDE THROW, FT.	281 169 22-27-38 14-18-24	375 225 26-30-45 16-19-27	469 281 29-35-51 18-22-30	563 337 30-37-54 19-24-33	656 394 33-40-58 21-26-35	750 450 35-42-62 22-27-38	844 506 38-46-66 24-29-40								
	4E	CFM/SIDE THROW, FT.	225 225 21-26-35 21-26-35	300 300 24-29-40 24-29-40	375 375 27-32-46 27-32-46	450 450 29-35-51 29-35-51	525 525 30-37-54 30-37-54	600 600 33-40-58 33-40-58	675 675 35-45-61 35-45-61								
	3A1	CFM/SIDE THROW, FT.	366 169 24-29-40 14-18-24	487 225 27-35-48 16-19-27	609 281 30-38-54 18-22-30	731 337 35-42-58 19-24-33	853 394 35-45-62 21-26-35	975 450 38-48-67 22-27-38	1098 506 40-51-70 24-29-40								
	3A2	CFM/SIDE THROW, FT.	300 300 25-31-43 20-23-32	400 400 29-34-50 23-27-40	500 500 32-40-58 27-31-43	600 600 34-41-61 29-32-47	700 700 40-45-65 31-34-50	800 800 40-47-70 32-40-54	900 900 43-52-74 34-40-58								
	2A 2B	CFM/SIDE THROW, FT.	450 24-29-40	600 27-35-48	750 30-38-54	900 35-42-58	1050 35-45-62	1200 38-48-67	1350 40-51-70								
2C 2E 2D 2F	CFM/SIDE THROW, FT.	562 338 26-30-45 21-26-35	750 450 29-35-51 24-29-40	938 562 32-40-58 27-32-46	1125 675 35-45-62 29-35-51	1313 787 37-48-67 30-37-54	1500 900 40-51-70 33-40-58	1688 1012 45-54-75 35-45-61									
1A 1B	CFM/SIDE THROW, FT.	900 30-38-53	1200 35-45-61	1500 40-51-69	1800 45-54-74	2100 48-58-80	2400 51-62-85	2700 54-66-91									

Notes:

1. Core style 4E is sized to give equal flow as near as possible in directions A and B.
2. For core styles 1A, 1B, 2A and 2B, the "A" direction is shown. Throw correction factor for "B" direction is: $A \times .82 = B$.

For performance notes, see page D37.

PERFORMANCE DATA:

MODELS 6500 AND 6200 • RECTANGULAR NECK

NOMINAL NECK SIZE	BLOW PATTERNS	NECK VELOCITY TP	300 .033		400 .058		500 .090		600 .130		700 .177		800 .231		900 .293		
			CFM NC	A B	A B	A B	A B	A B	A B	A B	A B	A B					
30 x 18 SQ. FT.	RETURN FACTORS —SP=3.1 TP NC + 7	CFM NC	1125 15		1500 23		1875 29		2250 34		2625 38		3000 42		3375 45		
	4B 4C	CFM/SIDE THROW, FT.	394 169 24-29-40 14-18-24	525 225 27-35-48 16-19-27	657 281 30-38-54 18-22-30	788 337 35-42-58 19-24-35	918 394 35-45-62 21-26-35	1050 450 38-48-67 22-27-38	1181 506 40-51-70 24-29-40								
	4E	CFM/SIDE THROW, FT.	281 281 22-27-38 22-27-38	375 375 26-30-45 26-30-45	469 469 29-35-51 29-35-51	563 563 30-37-54 30-37-54	657 657 32-40-58 32-40-58	750 750 35-42-62 35-42-62	845 845 38-46-66 38-46-66								
	3A1	CFM/SIDE THROW, FT.	478 169 26-30-45 14-18-24	637 225 29-35-51 16-19-27	797 281 32-40-58 18-22-30	956 337 35-45-62 19-24-35	1115 394 37-48-67 21-26-35	1275 450 40-51-70 22-27-38	1434 506 45-54-75 24-29-40								
	3A2	CFM/SIDE THROW, FT.	469 327 22-27-38 19-24-32	625 437 26-30-45 22-27-37	782 546 29-35-51 26-30-42	937 656 30-37-54 27-35-46	1093 766 32-40-58 29-35-50	1250 875 35-42-62 30-38-53	1406 984 38-46-66 35-40-56								
	2A 2B	CFM/SIDE THROW, FT.	562 26-30-45	750 29-35-51	937 32-40-58	1125 35-45-62	1312 37-48-67	1500 40-51-70	1687 45-54-75								
	2C 2E	CFM/SIDE THROW, FT.	787 337 29-35-51 21-26-35	1050 450 35-40-58 24-29-40	1313 562 38-46-66 27-32-46	1575 675 42-51-70 29-35-51	1838 787 45-54-75 30-37-54	2100 900 48-58-80 33-40-58	2363 1012 51-61-85 35-45-61								
1A 1B	CFM/SIDE THROW, FT.	1125 32-40-56	1500 37-46-62	1875 42-53-72	2250 46-56-78	2625 50-61-83	3000 53-64-91	3375 56-69-96									
36 x 18 SQ. FT.	RETURN FACTORS —SP=3.6 TP NC + 8	CFM NC	1350 16		1800 24		2250 30		2700 35		3150 39		3600 42		4050 45		
	4B 4C	CFM/SIDE THROW, FT.	506 169 26-30-45 14-18-24	675 225 29-35-51 16-19-27	844 281 33-40-58 18-22-30	1013 337 35-45-62 19-24-35	1181 394 37-48-67 21-26-35	1350 450 40-51-70 22-27-38	1519 506 45-54-75 24-29-40								
	4E	CFM/SIDE THROW, FT.	339 339 22-27-38 22-27-38	452 452 26-30-45 26-30-45	565 565 29-35-51 29-35-51	678 678 30-37-54 30-37-54	791 791 33-40-58 33-40-58	904 904 35-42-62 35-42-62	1020 1020 38-46-66 38-46-66								
	3A1	CFM/SIDE THROW, FT.	591 169 27-35-48 14-18-24	787 225 32-38-54 16-19-27	984 281 37-45-62 18-22-30	1181 337 38-48-66 19-24-35	1378 394 42-51-70 21-26-35	1575 450 46-56-75 22-27-38	1772 506 50-59-80 24-29-40								
	3B	CFM/SIDE THROW, FT.	675 337 27-35-48 21-26-35	900 450 32-38-54 24-29-40	1125 562 37-45-62 27-32-46	1350 675 38-48-66 29-35-51	1575 787 42-51-70 30-37-54	1800 900 46-56-75 33-40-58	2025 1012 50-59-80 35-45-61								
	2A 2B	CFM/SIDE THROW, FT.	675 27-35-48	900 32-38-54	1125 37-45-62	1350 38-48-66	1575 42-51-70	1800 46-56-75	2025 50-59-80								
	2C 2E	CFM/SIDE THROW, FT.	1010 337 32-40-56 21-26-35	1350 450 37-46-64 24-29-40	1688 562 42-53-72 27-32-46	2025 675 46-56-78 29-35-51	2363 787 50-61-83 30-37-54	2700 900 53-64-91 33-40-58	3038 1012 56-69-96 35-45-61								
1A 1B	CFM/SIDE THROW, FT.	1350 35-40-59	1800 38-48-67	2250 45-54-77	2700 48-58-82	3150 51-62-90	3600 54-67-93	4050 59-70-101									
24 x 21 SQ. FT.	RETURN FACTORS —SP=2.1 TP NC + 7	CFM NC	1050 15		1400 22		1750 28		2100 33		2450 37		2800 41		3150 44		
	4B 4C	CFM/SIDE THROW, FT.	295 230 20-25-34 17-20-29	394 306 24-29-39 19-24-32	493 382 27-32-44 20-27-37	590 460 29-37-49 22-29-39	690 535 31-37-53 24-31-42	788 612 32-41-56 25-32-44	887 688 37-42-59 27-37-49								
	3A1	CFM/SIDE THROW, FT.	410 230 25-31-42 17-20-29	547 306 29-37-51 19-24-32	684 382 32-41-58 20-27-37	820 460 37-44-61 22-29-39	957 535 37-48-66 24-31-42	1094 612 41-51-71 25-32-44	1231 688 42-54-75 27-37-49								
	3A2	CFM/SIDE THROW, FT.	375 300 25-31-42 19-22-31	500 400 29-37-51 22-25-37	625 500 32-41-58 25-29-41	750 600 37-44-61 27-31-44	875 700 37-48-66 29-32-48	1000 800 41-51-71 31-37-51	1125 900 42-54-75 32-37-54								
	2A 2B	CFM/SIDE THROW, FT.	525 27-32-48	700 31-37-54	875 34-42-61	1050 37-48-66	1225 39-51-71	1400 42-54-75	1575 48-58-80								
	2C 2E	CFM/SIDE THROW, FT.	591 459 29-37-51 24-29-41	788 612 34-41-58 27-32-48	986 764 39-48-66 31-37-54	1180 920 41-51-70 32-39-58	1380 1070 44-54-75 37-42-61	1576 1224 49-59-80 37-44-66	1774 1376 53-63-85 41-49-70								
	1A 1B	CFM/SIDE THROW, FT.	1050 34-42-59	1400 39-49-68	1750 44-56-76	2100 49-59-83	2450 53-65-88	2800 56-68-87	3150 59-73-102								

Notes:

1. Core style 4E is sized to give equal flow as near as possible in directions A and B.
2. For core styles 1A, 1B, 2A and 2B, the "A" direction is shown. Throw correction factor for "B" direction is: $A \times .82 = B$.

For performance notes, see page D37.

PERFORMANCE DATA:

MODELS 6500 AND 6200 • RECTANGULAR NECK

NOMINAL NECK SIZE	BLOW PATTERNS	NECK VELOCITY TP	300 .033		400 .058		500 .090		600 .130		700 .177		800 .231		900 .293										
			CFM NC	1310 16	A	B	1750 23	A	B	2185 29	A	B	2625 34	A	B	3060 38	A	B	3500 41	A	B	3935 44	A	B	
30 x 21 4.375 SQ. FT.	RETURN FACTORS —SP=3.1 TP NC + 8	CFM NC	1310 16	A	B	1750 23	A	B	2185 29	A	B	2625 34	A	B	3060 38	A	B	3500 41	A	B	3935 44	A	B		
	4B	4C	CFM/SIDE THROW, FT.	425 230	25-31-42	230 17-20-29	569 306	24-37-51	306 19-24-32	710 382	32-41-58	382 20-27-37	852 460	37-44-61	460 22-29-39	995 535	37-48-66	535 24-31-42	1138 612	41-51-71	612 25-32-44	1279 688	42-54-75	688 27-37-49	
	4E		CFM/SIDE THROW, FT.	360 295	24-29-41	295 27-32-48	480 394	27-32-48	394 31-37-54	600 492	31-37-54	492 32-39-58	720 591	32-39-58	591 37-42-61	840 690	37-42-61	690 37-44-66	960 788	37-44-66	788 41-49-70	1080 887	41-49-70	887	
	3A1		CFM/SIDE THROW, FT.	540 230	27-32-48	230 17-20-29	722 306	31-37-54	306 19-24-32	901 382	34-42-61	382 20-27-37	1082 460	37-48-66	460 22-29-39	1262 535	39-51-71	535 24-31-42	1444 612	42-54-75	612 25-32-44	1623 688	48-58-80	688 27-37-49	
	3A2		CFM/SIDE THROW, FT.	468 422	25-31-42	422 20-25-34	625 562	29-37-51	562 24-29-39	782 701	32-41-58	701 27-32-44	937 844	37-44-61	844 29-37-49	1093 983	37-48-66	983 31-37-53	1250 1125	41-51-71	1125 32-41-56	1406 1264	42-54-75	1264 37-42-61	
	2A	2B	CFM/SIDE THROW, FT.	655	29-37-51	875	34-41-58	1092	39-48-66	1312	41-51-70	1530	44-54-75	1750	49-59-80	1968	53-63-85								
	2C	2E	CFM/SIDE THROW, FT.	853 457	31-37-54	457 24-29-41	1138 612	37-42-61	612 27-32-48	1421 764	41-49-70	764 31-37-54	1705 920	44-54-75	920 32-39-58	1990 1070	48-58-80	1070 37-42-61	2276 1224	51-61-85	1224 37-44-66	2559 1376	54-65-90	1376 41-49-70	
1A	1B	CFM/SIDE THROW, FT.	1310	37-42-63	1750	41-51-71	2185	48-58-82	2625	51-61-87	3060	54-66-95	3500	58-71-99	3935	63-75-107									
36 x 21 5.25 SQ. FT.	RETURN FACTORS —SP=3.4 TP NC + 8	CFM NC	1575 16	A	B	2100 24	A	B	2625 30	A	B	3150 34	A	B	3675 38	A	B	4200 42	A	B	4725 45	A	B		
	4B	4C	CFM/SIDE THROW, FT.	558 230	27-32-48	230 17-20-29	744 306	31-37-54	306 19-24-32	930 382	34-42-61	382 20-27-37	1115 460	37-48-66	460 22-29-39	1306 535	39-51-71	535 24-31-42	1488 612	42-54-75	612 25-32-44	1674 688	48-58-80	688 27-37-49	
	4E		CFM/SIDE THROW, FT.	427 360	25-31-42	360 25-31-42	568 480	29-37-61	480 29-37-51	710 600	32-41-58	600 32-41-58	852 720	37-44-61	720 37-44-61	945 840	37-48-66	840 37-48-66	1135 960	41-51-71	960 41-51-71	1280 1080	42-54-75	1080 42-54-75	
	3A1		CFM/SIDE THROW, FT.	672 230	29-37-51	230 17-20-29	897 306	34-41-58	306 19-24-32	1121 382	39-48-66	382 20-27-37	1345 460	41-51-70	460 22-29-39	1570 535	44-54-75	535 24-31-42	1794 612	49-59-80	612 25-32-44	2018 688	53-63-85	688 27-37-49	
	3A2		CFM/SIDE THROW, FT.	675 450	25-31-42	450 22-27-37	900 600	29-37-51	600 25-31-42	1125 750	32-41-58	750 29-34-49	1350 900	37-44-61	900 31-37-54	1575 1050	37-48-66	1050 32-39-58	1800 1200	41-51-71	1200 34-42-61	2025 1350	42-54-75	1350 37-48-65	
	2A	2B	CFM/SIDE THROW, FT.	787	31-37-54	1050	37-42-61	1312	41-49-70	1575	44-54-75	1837	48-58-80	2100	51-61-85	2362	54-65-90								
	2C	2E	CFM/SIDE THROW, FT.	1115 460	34-42-59	460 24-29-41	1488 612	39-49-68	612 27-32-48	1861 764	44-56-76	764 31-37-54	2230 920	49-59-83	920 32-39-58	2605 1070	53-65-88	1070 37-42-61	2976 1224	56-68-97	1224 37-44-66	3349 1376	59-73-102	1376 41-49-70	
1A	1B	CFM/SIDE THROW, FT.	1575	41-51-70	2100	39-58-80	2625	54-66-90	3150	58-70-99	3675	61-75-105	4200	66-80-114	4725	70-85-122									
30 x 24 5.0 SQ. FT.	RETURN FACTORS —SP=3.1 TP NC + 8	CFM NC	1500 17	A	B	2000 25	A	B	2500 30	A	B	3000 35	A	B	3500 39	A	B	4000 43	A	B	4500 46	A	B		
	4B	4C	CFM/SIDE THROW, FT.	450 300	25-31-42	300 19-22-31	600 400	29-37-51	400 22-25-37	750 500	32-41-58	500 25-29-41	900 600	33-44-61	600 27-31-44	1050 700	37-48-66	700 29-32-48	1200 800	41-51-71	800 31-37-51	1350 900	42-54-75	900 32-37-54	
	4E		CFM/SIDE THROW, FT.	375 375	25-31-42	375 25-31-42	500 500	29-37-51	500 29-37-51	625 625	32-41-58	625 32-41-58	750 750	33-44-61	750 37-44-61	875 875	37-48-66	875 37-48-66	1000 1000	41-51-71	1000 41-51-71	1125 1125	42-54-75	1125 42-54-75	
	3A1		CFM/SIDE THROW, FT.	600 300	29-37-51	300 19-22-31	800 400	34-41-58	400 22-25-37	1000 500	39-48-66	500 25-29-41	1200 600	41-51-70	600 27-31-44	1400 700	44-54-75	700 29-32-48	1600 800	49-59-80	800 31-37-51	1800 900	53-63-85	900 32-37-54	
	3A2		CFM/SIDE THROW, FT.	515 470	31-37-54	470 25-31-42	687 625	37-42-61	625 29-37-51	859 782	41-49-70	782 32-41-58	1031 937	44-54-75	937 33-44-61	1203 1093	48-58-80	1093 37-48-66	1375 1250	51-61-85	1250 41-51-71	1548 1406	54-65-90	1406 42-54-75	
	2A	2B	CFM/SIDE THROW, FT.	750	32-41-56	1000	37-48-65	1250	42-54-73	1500	48-58-78	1750	51-61-85	2000	54-66-90	2250	58-70-97								
	2C	2E	CFM/SIDE THROW, FT.	900 600	37-42-63	600 29-37-51	1200 800	41-51-71	800 34-41-58	1500 1000	48-58-82	1000 39-48-66	1800 1200	51-61-87	1200 41-51-70	2100 1400	54-66-85	1400 44-54-75	2400 1600	58-71-99	1600 49-59-80	2700 1800	63-75-107	1800 53-63-85	
1A	1B	CFM/SIDE THROW, FT.	1500	38-47-67	2000	45-54-76	2500	48-61-85	3000	54-65-95	3500	58-72-99	4000	62-76-106	4500	66-79-113									

Notes:

1. Core style 4E is sized to give equal flow as near as possible in directions A and B.
2. For core styles 1A, 1B, 2A and 2B, the "A" direction is shown. Throw correction factor for "B" direction is: $A \times .82 = B$.

For performance notes, see page D37.

D
CEILING DIFFUSERS

PERFORMANCE DATA:

MODELS 6500 AND 6200 • RECTANGULAR NECK

NOMINAL NECK SIZE	BLOW PATTERNS	NECK VELOCITY TP	300 .033		400 .058		500 .090		600 .130		700 .177		800 .231		900 .293	
			CFM NC	1800 18	2400 25	3000 31	3600 36	4200 40	4800 43	5400 46						
36 x 24 6.0 SQ. FT.	RETURN FACTORS —SP=3.3 TP NC + 8	CFM NC	1800 18	2400 25	3000 31	3600 36	4200 40	4800 43	5400 46							
	4B 4C	CFM/SIDE THROW, FT.	600 300 29-37-51 19-22-31	800 400 34-41-58 22-25-37	1000 500 39-48-66 25-29-41	1200 600 41-51-70 27-31-44	1400 700 44-54-75 29-32-48	1600 800 49-59-80 31-37-51	1800 900 53-63-85 32-37-54							
	4E	CFM/SIDE THROW, FT.	450 450 25-31-42 24-31-42	600 600 29-37-51 29-37-51	750 750 32-41-58 32-41-58	900 900 35-44-61 35-44-61	1050 1050 37-48-66 37-48-66	1200 1200 41-51-71 41-51-71	1350 1350 42-54-75 42-54-75							
	3A1	CFM/SIDE THROW, FT.	750 300 31-37-54 19-22-31	1000 400 37-42-61 22-25-37	1250 500 41-49-70 25-29-41	1500 600 44-54-75 27-31-44	1750 700 48-58-80 29-32-48	2000 800 51-61-85 31-37-51	2250 900 54-65-90 32-37-54							
	3A2	CFM/SIDE THROW, FT.	676 562 27-32-48 24-29-41	900 750 34-37-54 27-32-48	1125 937 34-42-61 31-37-54	1350 1125 37-48-66 32-39-58	1575 1312 39-51-71 35-42-61	1800 1500 42-54-75 37-44-66	2025 1687 48-58-80 41-49-70							
	2A	CFM/SIDE THROW, FT.	900 32-41-56	1200 37-48-65	1500 42-54-73	1800 48-58-78	2100 51-61-85	2400 54-66-90	2700 58-70-97							
	2B	CFM/SIDE THROW, FT.	900 32-41-56	1200 37-48-65	1500 42-54-73	1800 48-58-78	2100 51-61-85	2400 54-66-90	2700 58-70-97							
	2C 2D	CFM/SIDE THROW, FT.	1200 600 37-42-63 25-31-42	1600 800 41-51-71 29-37-51	2000 1000 48-58-82 32-41-58	2400 1200 51-61-87 35-44-61	2800 1400 54-66-95 37-48-66	3200 1600 58-71-99 41-51-71	3600 1800 63-75-107 42-54-75							
	2E	CFM/SIDE THROW, FT.	1200 600 37-42-63 25-31-42	1600 800 41-51-71 29-37-51	2000 1000 48-58-82 32-41-58	2400 1200 51-61-87 35-44-61	2800 1400 54-66-95 37-48-66	3200 1600 58-71-99 41-51-71	3600 1800 63-75-107 42-54-75							
	1A 1B	CFM/SIDE THROW, FT.	1800 41-51-70	2400 48-58-80	3000 54-66-90	3600 58-70-99	4200 61-75-105	4800 66-80-114	5400 70-85-122							
36 x 30 7.5 SQ. FT.	RETURN FACTORS —SP=3.4 TP NC + 8	CFM NC	2250 19	3000 26	3750 32	4500 37	5250 41	6000 44	6750 47							
	4B 4C	CFM/SIDE THROW, FT.	657 468 29-37-51 20-25-34	875 625 34-41-58 24-29-39	1093 782 39-48-66 27-32-44	1313 937 41-51-70 29-37-49	1532 1093 44-54-75 31-37-53	1750 1250 49-59-80 32-41-56	1969 1406 53-63-85 37-42-59							
	3A1	CFM/SIDE THROW, FT.	890 468 32-41-56 20-25-34	1187 625 37-48-65 24-29-39	1484 782 42-54-73 27-32-44	1781 937 48-58-78 29-37-49	2078 1093 51-61-85 31-37-53	2375 1250 54-66-90 32-41-56	2672 1406 58-70-97 37-42-59							
	3A2	CFM/SIDE THROW, FT.	787 675 31-37-54 22-27-37	1050 900 37-42-61 25-31-42	1312 1125 41-49-70 29-34-49	1575 1350 44-54-75 31-37-54	1837 1575 48-58-80 32-39-58	2100 1800 51-61-85 37-42-61	2362 2025 54-65-90 37-48-65							
	2A	CFM/SIDE THROW, FT.	1125 34-42-59	1500 39-49-68	1875 44-56-76	2250 49-59-83	2625 53-65-88	3000 56-68-97	3375 59-73-102							
	2B	CFM/SIDE THROW, FT.	1125 34-42-59	1500 39-49-68	1875 44-56-76	2250 49-59-83	2625 53-65-88	3000 56-68-97	3375 59-73-102							
	2C 2D	CFM/SIDE THROW, FT.	1312 938 37-42-63 29-37-51	1750 1250 41-51-71 34-41-58	2188 1562 48-58-82 39-48-66	2625 1875 51-61-87 41-51-70	3063 2187 54-66-95 44-54-75	3500 2500 58-71-99 49-59-80	3938 2812 63-75-107 53-63-85							
	2E	CFM/SIDE THROW, FT.	1312 938 37-42-63 29-37-51	1750 1250 41-51-71 34-41-58	2188 1562 48-58-82 39-48-66	2625 1875 51-61-87 41-51-70	3063 2187 54-66-95 44-54-75	3500 2500 58-71-99 49-59-80	3938 2812 63-75-107 53-63-85							
	1A 1B	CFM/SIDE THROW, FT.	2250 48-60-82	3000 56-68-94	3750 64-78-106	4500 68-82-116	5250 72-88-124	6000 78-94-134	6750 82-100-144							

Notes:

- Core style 4E is sized to give equal flow as near as possible in directions A and B.
- For core styles 1A, 1B, 2A and 2B, the "A" direction is shown. Throw correction factor for "B" direction is: $A \times .82 = B$.

- CFM** - cubic feet per minute
TP - total pressure - inches w.g.
T - throw in feet
NC - Noise Criteria (values) based on 10 dB room absorption, re 10^{-12} watts.
Neck Velocity – feet per minute

Performance Notes:

- Throw values are given for terminal velocities of 150, 100 and 50 fpm under isothermal conditions. Data applies to ceiling mounted units when the maximum coanda effect applies. When no ceiling is present (exposed duct), throws are reduced by approximately 25%.
- Sound levels in performance tables are for steel construction – **Model 6500**. Apply the following corrections for aluminum construction – **Model 6200**.
 TP = Listed value x 1.25.
 NC = Listed value + 4.
- Performance data as tabulated is for supply air conditions. Correction factors for return air application - see next page.
- Correction factors for adjustable models - see next page.
- Correction factors for round inlets - see next page.
- Data derived from tests conducted in accordance with ANSI/ASHRAE Standard 70 – 2006.

PERFORMANCE DATA CORRECTIONS:

MODELS 6500 AND 6200

CORRECTION FACTORS FOR RETURN INLET

If the unit is used as a return inlet, the performance data is obtained by applying the return corrections, as follows:

- Add the NC correction at the left side of the table to the NC value listed in the performance table.
- Multiply the listed SP factor at the left side of the table by the total pressure (TP) listed at the top of the table.

CORRECTION FACTORS FOR MODELS 6550 AND 6250 (ADJUSTABLE PATTERN CONTROLLERS) – TABLE 2

Refer to the performance data for the **Models 6500 and 6200**. Apply the corrections from Table 2 to the data for square, 4-way core styles, as follows:

- NC = listed + correction
- Total Pressure = listed x factor
- Horizontal Throw = listed
- Vertical Throw = listed x factor

Apply the throw factor to the 50 fpm terminal velocity throw only.

Example:

18" x 18", **Model 6500**, 1350 cfm, 20°F temperature difference heating, vertical projection, (Page D23).

- NC = 31 + 6 = 37
- TP = .13 x 2.1 = .273
- Throw = 36 x .9 = 32.4 feet @ 50 fpm terminal velocity.

CORRECTION FACTORS WITH SQUARE TO ROUND INLET ADAPTOR – TABLE 3

- Add the NC correction factor from Table 3 and the NC value listed in the performance tables.
- Multiply the correction factor from Table 3 by the listed total pressure in the performance tables.
- Multiply the correction factor from Table 3 by the listed throws in the performance tables.

Example:

12" x 12" unit with 10" round adaptor handling 500 cfm supply air. (Page D23).

- NC = 23 + 7 = 30
- Total Pressure = .09 x 1.65 = 0.149
- Throw = 21 x 1.15 = 24.15 feet @ 50 fpm terminal velocity.

Example:

12" x 12" unit handling 600 cfm of return air. (Page D23).

- Return NC = 28 + 4 = 32.
- Return negative SP = 1.3 x (-.13) = -.169.

TABLE 2 Correction Factors 6550/6250 Adjustable

NECK SIZE	NC (add)		TOTAL PRESSURE (multiply)		VERTICAL THROW (multiply)			
					COOLING, ΔT		HEATING, ΔT	
	H	V	H	V	20°F	0°F	20°F	40°F
6 x 6	2	6	1.2	1.5	1.3	1.1	0.8	0.6
9 x 9	2	6	1.4	2.1	1.5	1.2	0.9	0.6
12 x 12	2	6	1.4	2.1	1.6	1.3	1.0	0.6
15 x 15	2	6	1.4	2.1	1.7	1.3	1.0	0.6
18 x 18	2	6	1.4	2.1	1.7	1.3	0.9	0.6
21 x 21	2	6	1.4	2.1	1.7	1.3	0.8	0.5
24 x 24	2	6	1.6	2.2	1.5	1.1	0.7	0.3

TABLE 3 Correction Factors for SR Adaptors

SQUARE INLET	ROUND INLET	NC (add)	TP (multiply)	THROW (multiply)		
				150	100	50
6 x 6	5	7	1.65	1.10	1.10	1.15
9 x 9	6	17	3.50	1.15	1.15	1.20
9 x 9	8	4	1.40	1.10	1.10	1.10
12 x 12	8	17	3.50	1.15	1.15	1.20
12 x 12	10	7	1.65	1.10	1.10	1.15
15 x 15	10	17	3.50	1.15	1.15	1.20
15 x 15	12	9	1.90	1.10	1.10	1.15
15 x 15	14	3	1.25	1.05	1.05	1.10
18 x 18	12	17	3.50	1.15	1.15	1.20
18 x 18	14	10	2.00	1.10	1.10	1.15
18 x 18	16	5	1.45	1.10	1.10	1.10
21 x 21	14	17	3.70	1.15	1.15	1.20
21 x 21	16	11	2.25	1.10	1.10	1.15
21 x 21	18	6	1.60	1.10	1.10	1.10
21 x 21	20	3	1.20	1.05	1.05	1.10
24 x 24	16	17	3.50	1.15	1.15	1.20
24 x 24	18	12	2.35	1.10	1.10	1.15
24 x 24	20	7	1.65	1.10	1.10	1.15
24 x 24	22	4	1.33	1.05	1.05	1.10

PERFORMANCE DATA:

MODELS 6500 AND 6200 • SQUARE NECK

NOMINAL NECK SIZE	BLOW PATTERNS	NECK VELOCITY TP	300 .033	400 .058	500 .090	600 .130	700 .177	800 .231	900 .293
6 x 6 .25 SQ. FT.	RETURN FACTORS —SP=1.1 TP NC + 1	CFM NC	75 —	100 10	125 17	150 22	175 26	200 31	225 35
	4A	CFM/SIDE THROW, FT.	19 4-5-8	25 4-6-10	31 6-8-10	37 6-8-11	44 8-9-12	50 8-9-12	56 9-10-13
	3A	CFM/SIDE THROW, FT.	19 28 4-5-8	25 38 5-8-11	31 47 6-8-10 8-10-14	37 56 6-8-11 8-11-15	44 66 8-9-12 9-12-16	50 75 8-9-12 9-12-17	56 85 9-10-13 10-13-18
	2S 2G	CFM/SIDE THROW, FT.	37 8-9-12	50 9-10-14	62 10-11-16	75 11-12-17	88 12-13-18	100 12-13-19	113 12-14-20
	1S	CFM/SIDE THROW, FT.	75 9-11-15	100 10-12-17	125 11-14-19	150 12-15-22	175 13-16-22	200 14-17-24	225 15-18-25
9 x 9 .56 SQ. FT.	RETURN FACTORS —SP=1.2 TP NC + 2	CFM NC	170 —	225 14	280 20	340 26	395 31	450 35	505 38
	4A	CFM/SIDE THROW, FT.	42 6-8-12	56 7-10-14	70 10-11-15	84 10-12-16	98 11-12-17	112 11-14-19	126 12-15-20
	3A	CFM/SIDE THROW, FT.	42 63 6-8-12	56 85 9-11-14	70 106 10-12-17	84 127 10-12-16 12-14-20	98 148 11-12-17 13-15-21	112 169 11-14-19 13-16-22	126 190 12-15-20 14-18-24
	2S 2G	CFM/SIDE THROW, FT.	84 9-10-15	112 11-13-18	141 12-15-20	169 13-16-22	197 14-17-23	225 15-18-25	253 16-19-28
	1S	CFM/SIDE THROW, FT.	169 12-15-20	225 14-17-23	282 16-19-26	338 17-22-29	394 18-22-31	450 19-24-33	507 22-25-35
12 x 12 1.0 SQ. FT.	RETURN FACTORS —SP=1.3 TP NC + 4	CFM NC	300 10	400 17	500 23	600 28	700 33	800 36	900 39
	4A	CFM/SIDE THROW, FT.	75 8-13-15	100 11-14-18	125 13-15-21	150 14-17-22	175 14-18-24	200 15-20-25	225 17-21-27
	3A	CFM/SIDE THROW, FT.	75 112 8-13-15	100 150 11-14-18	125 187 12-15-21	150 225 13-15-21 14-17-24	175 262 14-18-24 16-20-27	200 300 15-20-25 17-21-30	225 338 17-21-27 19-22-31
	2S 2G	CFM/SIDE THROW, FT.	150 12-15-20	200 15-17-25	250 17-19-27	300 18-20-29	350 19-21-31	400 20-25-34	450 21-25-36
	1S	CFM/SIDE THROW, FT.	300 16-20-28	400 18-22-32	500 21-25-37	600 22-26-39	700 23-28-41	800 25-29-41	900 28-33-47
15 x 15 1.56 SQ. FT.	RETURN FACTORS —SP=1.8 TP NC + 4	CFM NC	465 10	625 19	780 25	935 30	1090 33	1250 39	1400 41
	4A	CFM/SIDE THROW, FT.	117 13-16-21	156 14-18-24	195 16-19-27	234 18-21-29	273 19-22-30	312 20-24-33	350 21-26-35
	3A	CFM/SIDE THROW, FT.	117 175 13-16-21	156 234 14-17-23	195 292 14-18-24 17-19-29	234 351 16-19-27 19-22-31	273 409 18-21-29 21-23-34	312 468 19-22-30 22-25-36	350 527 19-24-35 22-29-39
	2S 2G	CFM/SIDE THROW, FT.	234 16-20-27	312 19-22-31	390 21-25-36	468 22-27-40	546 24-29-42	625 27-31-45	700 27-35-47
	1S	CFM/SIDE THROW, FT.	467 21-25-36	625 23-29-42	780 26-32-47	935 29-36-51	1090 30-39-55	1250 32-42-57	1400 36-44-61
18 x 18 2.25 SQ. FT.	RETURN FACTORS —SP=2.1 TP NC + 6	CFM NC	675 12	900 21	1125 27	1350 31	1575 36	1800 39	2025 42
	4A	CFM/SIDE THROW, FT.	168 15-19-25	225 17-20-29	281 19-24-32	337 20-25-36	394 22-27-37	450 24-29-41	506 25-31-43
	3A	CFM/SIDE THROW, FT.	168 253 15-19-25	225 338 17-22-29	281 422 17-20-29 20-25-33	337 506 19-24-32 23-27-38	394 590 20-25-36 25-32-42	450 675 22-27-37 26-32-45	506 760 24-29-41 27-35-48
	2S 2G	CFM/SIDE THROW, FT.	337 19-23-32	450 22-26-38	562 24-30-43	675 26-31-46	787 30-34-49	900 30-35-53	1012 32-39-55
	1S	CFM/SIDE THROW, FT.	675 25-33-45	900 30-36-51	1125 34-42-58	1350 36-45-61	1575 39-48-66	1800 43-52-70	2025 46-55-75

For performance notes, see page D37.

PERFORMANCE DATA:

MODELS 6500 AND 6200 • SQUARE NECK

NOMINAL NECK SIZE	BLOW PATTERNS	NECK VELOCITY TP	300 .033	400 .058	500 .090	600 .130	700 .177	800 .231	900 .293
21 x 21 3.06 SQ. FT.	RETURN FACTORS —SP=2.6 TP NC + 8	CFM NC	915 14	1225 22	1530 28	1835 32	2140 37	2450 40	2750 43
	4A	CFM/SIDE THROW, FT.	230 18-21-30	306 19-25-34	382 21-28-39	460 23-30-41	535 25-32-44	612 26-34-46	688 28-39-51
	3A	CFM/SIDE THROW, FT.	230 345 15-19-26 20-25-34	306 460 17-22-29 23-28-39	382 573 19-25-34 26-31-45	460 688 20-26-36 28-34-50	535 802 22-28-39 29-36-53	612 918 23-29-40 34-39-56	688 1030 25-34-45 34-43-59
	2S 2G	CFM/SIDE THROW, FT.	458 22-27-39	612 25-31-45	765 28-35-50	917 31-39-55	1070 32-42-59	1225 35-45-62	1375 39-48-66
	1S	CFM/SIDE THROW, FT.	917 29-37-51	1225 34-43-59	1530 39-50-67	1835 43-53-71	2140 46-56-77	2450 50-60-82	2750 53-64-88
24 x 24 4.0 SQ. FT.	RETURN FACTORS —SP=2.7 TP NC + 8	CFM NC	1200 15	1600 23	2000 29	2400 33	2800 37	3200 41	3600 44
	4A	CFM/SIDE THROW, FT.	300 20-24-33	400 24-27-40	500 27-31-44	600 29-33-47	700 31-35-51	800 33-40-55	900 35-40-58
	3A	CFM/SIDE THROW, FT.	300 450 20-24-33 23-28-39	400 600 24-27-40 26-31-46	500 750 27-31-44 29-36-52	600 900 29-33-47 31-38-56	700 1050 31-33-51 36-41-59	800 1200 33-40-55 36-43-64	900 1350 35-40-58 39-47-67
	2S 2G	CFM/SIDE THROW, FT.	600 25-33-45	800 30-36-51	1000 34-42-58	1200 36-45-61	1400 39-48-66	1600 43-52-70	1800 46-55-75
	1S	CFM/SIDE THROW, FT.	1200 35-40-59	1600 38-48-67	2000 45-54-77	2400 48-58-82	2800 51-62-90	3200 54-67-93	3600 59-70-101
30 x 30 6.25 SQ. FT.	RETURN FACTORS —SP=3.1 TP NC + 8	CFM NC	1875 16	2500 24	3125 30	3750 35	4375 39	5000 42	5625 46
	4A	CFM/SIDE THROW, FT.	469 25-31-42	625 29-36-48	782 34-40-55	937 36-44-61	1093 38-46-65	1250 40-50-69	1406 46-52-73
	3A	CFM/SIDE THROW, FT.	469 703 25-31-42 28-34-49	625 938 29-36-48 32-39-57	782 1172 34-40-55 35-44-64	937 1405 36-44-61 39-49-69	1093 1640 38-46-65 41-49-74	1250 1875 40-50-69 44-57-78	1406 2110 46-52-73 49-60-83
	2S 2G	CFM/SIDE THROW, FT.	937 32-40-55	1250 37-47-63	1562 42-53-72	1875 47-57-77	2187 50-60-83	2500 53-65-88	2812 57-68-95
	1S	CFM/SIDE THROW, FT.	1875 42-53-72	2500 49-60-83	3125 56-69-93	3750 60-72-102	4375 63-77-109	5000 69-83-116	5625 72-88-123
36 x 36 9.0 SQ. FT.	RETURN FACTORS —SP=3.6 TP NC + 9	CFM NC	2700 18	3600 25	4500 31	5400 36	6300 40	7200 44	8100 48
	4A	CFM/SIDE THROW, FT.	675 30-37-51	900 34-41-57	1125 39-46-67	1350 41-51-74	1575 44-53-78	1800 51-57-83	2025 51-64-87
	3A	CFM/SIDE THROW, FT.	675 1010 30-37-51 34-44-60	900 1350 34-41-57 40-48-68	1125 1687 39-46-67 46-56-78	1350 2025 41-51-74 48-60-82	1575 2362 44-53-78 52-64-88	1800 2700 51-57-83 58-70-94	2025 3038 51-64-87 62-74-100
	2S 2G	CFM/SIDE THROW, FT.	1350 40-45-67	1800 43-54-76	2250 50-61-86	2700 54-65-92	3150 58-70-101	3600 61-76-104	4050 67-79-113
	1S	CFM/SIDE THROW, FT.	2700 49-61-85	3600 59-70-99	4500 66-80-114	5400 72-85-122	6300 76-91-131	7200 82-97-142	8100 87-106-150

For performance notes, see page D37.

PERFORMANCE DATA:

MODELS 6500 AND 6200 • RECTANGULAR NECK

NOMINAL NECK SIZE	BLOW PATTERNS	NECK VELOCITY TP	300 .033		400 .058		500 .090		600 .130		700 .177		800 .231		900 .293	
			CFM NC	1800 18	2400 25	3000 31	3600 36	4200 40	4800 43	5400 46						
36 x 24 6.0 SQ. FT.	RETURN FACTORS —SP=3.3 TP NC + 8	CFM NC	1800 18	2400 25	3000 31	3600 36	4200 40	4800 43	5400 46							
	4B 4C	CFM/SIDE THROW, FT.	600 300 29-37-51 19-22-31	800 400 34-41-58 22-25-37	1000 500 39-48-66 25-29-41	1200 600 41-51-70 27-31-44	1400 700 44-54-75 29-32-48	1600 800 49-59-80 31-37-51	1800 900 53-63-85 32-37-54							
	4E	CFM/SIDE THROW, FT.	450 450 25-31-42 24-31-42	600 600 29-37-51 29-37-51	750 750 32-41-58 32-41-58	900 900 35-44-61 35-44-61	1050 1050 37-48-66 37-48-66	1200 1200 41-51-71 41-51-71	1350 1350 42-54-75 42-54-75							
	3A1	CFM/SIDE THROW, FT.	750 300 31-37-54 19-22-31	1000 400 37-42-61 22-25-37	1250 500 41-49-70 25-29-41	1500 600 44-54-75 27-31-44	1750 700 48-58-80 29-32-48	2000 800 51-61-85 31-37-51	2250 900 54-65-90 32-37-54							
	3A2	CFM/SIDE THROW, FT.	676 562 27-32-48 24-29-41	900 750 34-37-54 27-32-48	1125 937 34-42-61 31-37-54	1350 1125 37-48-66 32-39-58	1575 1312 39-51-71 35-42-61	1800 1500 42-54-75 37-44-66	2025 1687 48-58-80 41-49-70							
	2A	CFM/SIDE THROW, FT.	900 32-41-56	1200 37-48-65	1500 42-54-73	1800 48-58-78	2100 51-61-85	2400 54-66-90	2700 58-70-97							
	2B	CFM/SIDE THROW, FT.	900 32-41-56	1200 37-48-65	1500 42-54-73	1800 48-58-78	2100 51-61-85	2400 54-66-90	2700 58-70-97							
	2C 2D	CFM/SIDE THROW, FT.	1200 600 37-42-63 25-31-42	1600 800 41-51-71 29-37-51	2000 1000 48-58-82 32-41-58	2400 1200 51-61-87 35-44-61	2800 1400 54-66-95 37-48-66	3200 1600 58-71-99 41-51-71	3600 1800 63-75-107 42-54-75							
	2E	CFM/SIDE THROW, FT.	1200 600 37-42-63 25-31-42	1600 800 41-51-71 29-37-51	2000 1000 48-58-82 32-41-58	2400 1200 51-61-87 35-44-61	2800 1400 54-66-95 37-48-66	3200 1600 58-71-99 41-51-71	3600 1800 63-75-107 42-54-75							
	1A 1B	CFM/SIDE THROW, FT.	1800 41-51-70	2400 48-58-80	3000 54-66-90	3600 58-70-99	4200 61-75-105	4800 66-80-114	5400 70-85-122							
36 x 30 7.5 SQ. FT.	RETURN FACTORS —SP=3.4 TP NC + 8	CFM NC	2250 19	3000 26	3750 32	4500 37	5250 41	6000 44	6750 47							
	4B 4C	CFM/SIDE THROW, FT.	657 468 29-37-51 20-25-34	875 625 34-41-58 24-29-39	1093 782 39-48-66 27-32-44	1313 937 41-51-70 29-37-49	1532 1093 44-54-75 31-37-53	1750 1250 49-59-80 32-41-56	1969 1406 53-63-85 37-42-59							
	3A1	CFM/SIDE THROW, FT.	890 468 32-41-56 20-25-34	1187 625 37-48-65 24-29-39	1484 782 42-54-73 27-32-44	1781 937 48-58-78 29-37-49	2078 1093 51-61-85 31-37-53	2375 1250 54-66-90 32-41-56	2672 1406 58-70-97 37-42-59							
	3A2	CFM/SIDE THROW, FT.	787 675 31-37-54 22-27-37	1050 900 37-42-61 25-31-42	1312 1125 41-49-70 29-34-49	1575 1350 44-54-75 31-37-54	1837 1575 48-58-80 32-39-58	2100 1800 51-61-85 37-42-61	2362 2025 54-65-90 37-48-65							
	2A	CFM/SIDE THROW, FT.	1125 34-42-59	1500 39-49-68	1875 44-56-76	2250 49-59-83	2625 53-65-88	3000 56-68-97	3375 59-73-102							
	2B	CFM/SIDE THROW, FT.	1125 34-42-59	1500 39-49-68	1875 44-56-76	2250 49-59-83	2625 53-65-88	3000 56-68-97	3375 59-73-102							
	2C 2D	CFM/SIDE THROW, FT.	1312 938 37-42-63 29-37-51	1750 1250 41-51-71 34-41-58	2188 1562 48-58-82 39-48-66	2625 1875 51-61-87 41-51-70	3063 2187 54-66-95 44-54-75	3500 2500 58-71-99 49-59-80	3938 2812 63-75-107 53-63-85							
	2E	CFM/SIDE THROW, FT.	1312 938 37-42-63 29-37-51	1750 1250 41-51-71 34-41-58	2188 1562 48-58-82 39-48-66	2625 1875 51-61-87 41-51-70	3063 2187 54-66-95 44-54-75	3500 2500 58-71-99 49-59-80	3938 2812 63-75-107 53-63-85							
	1A 1B	CFM/SIDE THROW, FT.	2250 48-60-82	3000 56-68-94	3750 64-78-106	4500 68-82-116	5250 72-88-124	6000 78-94-134	6750 82-100-144							

Notes:

1. Core style 4E is sized to give equal flow as near as possible in directions A and B.
2. For core styles 1A, 1B, 2A and 2B, the "A" direction is shown. Throw correction factor for "B" direction is: $A \times .82 = B$.

- CFM** - cubic feet per minute
TP - total pressure - inches w.g.
T - throw in feet
NC - Noise Criteria (values) based on 10 dB room absorption, re 10^{-12} watts.
Neck Velocity – feet per minute

Performance Notes:

1. Throw values are given for terminal velocities of 150, 100 and 50 fpm under isothermal conditions. Data applies to ceiling mounted units when the maximum coanda effect applies. When no ceiling is present (exposed duct), throws are reduced by approximately 25%.
2. Sound levels in performance tables are for steel construction – **Model 6500**. Apply the following corrections for aluminum construction – **Model 6200**.
TP = Listed value x 1.25.
NC = Listed value + 4.
3. Performance data as tabulated is for supply air conditions. Correction factors for return air application - see next page.
4. Correction factors for adjustable models - see next page.
5. Correction factors for round inlets - see next page.
6. Data derived from tests conducted in accordance with ANSI/ASHRAE Standard 70 – 2006.

PERFORMANCE DATA CORRECTIONS:

MODELS 6500 AND 6200

CORRECTION FACTORS FOR RETURN INLET

If the unit is used as a return inlet, the performance data is obtained by applying the return corrections, as follows:

- Add the NC correction at the left side of the table to the NC value listed in the performance table.
- Multiply the listed SP factor at the left side of the table by the total pressure (TP) listed at the top of the table.

CORRECTION FACTORS FOR MODELS 6550 AND 6250 (ADJUSTABLE PATTERN CONTROLLERS) – TABLE 2

Refer to the performance data for the **Models 6500 and 6200**. Apply the corrections from Table 2 to the data for square, 4-way core styles, as follows:

- NC = listed + correction
- Total Pressure = listed x factor
- Horizontal Throw = listed
- Vertical Throw = listed x factor

Apply the throw factor to the 50 fpm terminal velocity throw only.

Example:

18" x 18", **Model 6500**, 1350 cfm, 20°F temperature difference heating, vertical projection, (Page D23).

- NC = 31 + 6 = 37
- TP = .13 x 2.1 = .273
- Throw = 36 x .9 = 32.4 feet @ 50 fpm terminal velocity.

CORRECTION FACTORS WITH SQUARE TO ROUND INLET ADAPTOR – TABLE 3

- Add the NC correction factor from Table 3 and the NC value listed in the performance tables.
- Multiply the correction factor from Table 3 by the listed total pressure in the performance tables.
- Multiply the correction factor from Table 3 by the listed throws in the performance tables.

Example:

12" x 12" unit with 10" round adaptor handling 500 cfm supply air. (Page D23).

- NC = 23 + 7 = 30
- Total Pressure = .09 x 1.65 = 0.149
- Throw = 21 x 1.15 = 24.15 feet @ 50 fpm terminal velocity.

Example:

12" x 12" unit handling 600 cfm of return air. (Page D23).

- Return NC = 28 + 4 = 32.
- Return negative SP = 1.3 x (-.13) = -.169.

TABLE 2 Correction Factors 6550/6250 Adjustable

NECK SIZE	NC (add)		TOTAL PRESSURE (multiply)		VERTICAL THROW (multiply)			
					COOLING, ΔT	HEATING, ΔT		
	H	V	H	V	20°F	0°F	20°F	40°F
6 x 6	2	6	1.2	1.5	1.3	1.1	0.8	0.6
9 x 9	2	6	1.4	2.1	1.5	1.2	0.9	0.6
12 x 12	2	6	1.4	2.1	1.6	1.3	1.0	0.6
15 x 15	2	6	1.4	2.1	1.7	1.3	1.0	0.6
18 x 18	2	6	1.4	2.1	1.7	1.3	0.9	0.6
21 x 21	2	6	1.4	2.1	1.7	1.3	0.8	0.5
24 x 24	2	6	1.6	2.2	1.5	1.1	0.7	0.3

TABLE 3 Correction Factors for SR Adaptors

SQUARE INLET	ROUND INLET	NC (add)	TP (multiply)	THROW (multiply)		
				150	100	50
6 x 6	5	7	1.65	1.10	1.10	1.15
9 x 9	6	17	3.50	1.15	1.15	1.20
9 x 9	8	4	1.40	1.10	1.10	1.10
12 x 12	8	17	3.50	1.15	1.15	1.20
12 x 12	10	7	1.65	1.10	1.10	1.15
15 x 15	10	17	3.50	1.15	1.15	1.20
15 x 15	12	9	1.90	1.10	1.10	1.15
15 x 15	14	3	1.25	1.05	1.05	1.10
18 x 18	12	17	3.50	1.15	1.15	1.20
18 x 18	14	10	2.00	1.10	1.10	1.15
18 x 18	16	5	1.45	1.10	1.10	1.10
21 x 21	14	17	3.70	1.15	1.15	1.20
21 x 21	16	11	2.25	1.10	1.10	1.15
21 x 21	18	6	1.60	1.10	1.10	1.10
21 x 21	20	3	1.20	1.05	1.05	1.10
24 x 24	16	17	3.50	1.15	1.15	1.20
24 x 24	18	12	2.35	1.10	1.10	1.15
24 x 24	20	7	1.65	1.10	1.10	1.15
24 x 24	22	4	1.33	1.05	1.05	1.10