



**STATIC THINLINE CURTAIN TYPE FIRE DAMPER**  
**3 HR. LABEL • VERTICAL MOUNT**  
**FOR USE IN STATIC SYSTEMS**  
**MODELS: 0570V, 0580V AND 0590V**



**QUALIFICATIONS:**

- **UL 555 & CAN/ULC-S112 CLASSIFIED FIRE DAMPER. 3 hr. label (File # R9492).**
- **Meets all the requirements of UL and NFPA 80, 90A and 101 for fire dampers in static HVAC systems, as well as IBC and NBC (Canada) Building Code requirements.**
- **City of New York Board of Standards and Appeals. Cal. No. 460-88-SA.**
- **California State Fire Marshal: Fire Damper Listing No. 3225-0935:0100.**

Model 0570 curtain fire damper is UL approved for use where local building codes require the protection of HVAC ductwork penetrations in walls and partitions that have a fire resistance rating of up to 4 hours. The 0570 is classified for use only in static "fans off" systems where the HVAC system is automatically shut down in the event of a fire alarm.

Thinline fire dampers are only 2" (51) deep and permit installation in narrow fire partitions, transfer openings, behind grilles or in any application where clearance is restricted.

**STANDARD CONSTRUCTION:**

- Frame:** 2" (51) wide, 22 ga. (0.85) roll-formed G60 galv. steel.  
**Blades:** Curtain type interlocking blades, 22 ga. (0.85) roll-formed G60 galvanized steel.  
**Fusible Link:** 165°F (74°C) standard. UL Listed. 212°F (100°C) available.  
**Blade Closure:** Vertical mount model; gravity.

**Sizes (Duct W x H):**

Model Type	Minimum	Maximum
	Single Section	Single Section
	Vertical	Vertical
0570V A	4" x 4" (102 x 102)	36" x 60" (914 x 1524)
0580V B	4" x 3" (102 x 76)	36" x 50" (914 x 1270)
0590V Round/CR	3" (76) dia.	34" (864) dia.
0590V Oval/CO	4" x 3" (102 x 76)	34" x 49" (864 x 1245)
0590V Square/Rect./CSR	3" x 3" (76 x 76)	34" x 49" (864 x 1245)

**Note:** For horizontal mount applications, contact factory.

**OPTIONS:**

- Non-standard temperature fusible link. Specify \_\_\_\_\_.
- Factory Sleeve. Available in 10 (3.5) through 22 ga. (0.85) galv. steel and in lengths required for application. Specify: \_\_\_\_\_ length. \_\_\_\_\_ ga.

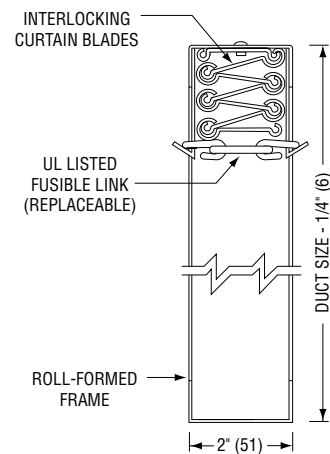
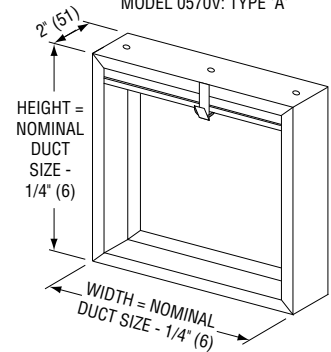
**Type C Options:**

- LP** Unsealed. Suitable for low pressure systems.
- HP** Sealed. Suitable for medium/high pressure systems. Externally caulked. (Up to 6 w.g. [1.5 kPa]).

**NOTES:**

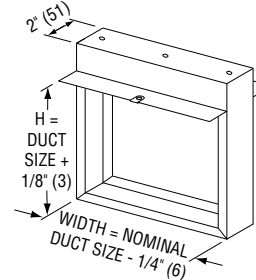
1. See sizing chart for relationship of duct size and damper size on Type B & C. Refer to drawing SC3.

MODEL 0570V: TYPE 'A'

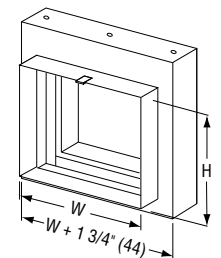


MODEL 0570V – VERTICAL MOUNT

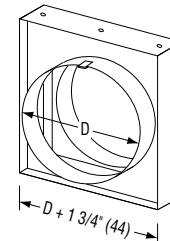
MODEL 0580V: TYPE 'B'



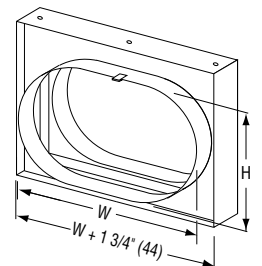
MODEL 0590V: TYPE 'CSR' RECTANGULAR



MODEL 0590V: TYPE 'CR' ROUND



MODEL 0590V: TYPE 'CO' FLAT OVAL



For installation instructions, see IOM-FDINST. Dimensions are in inches (mm).

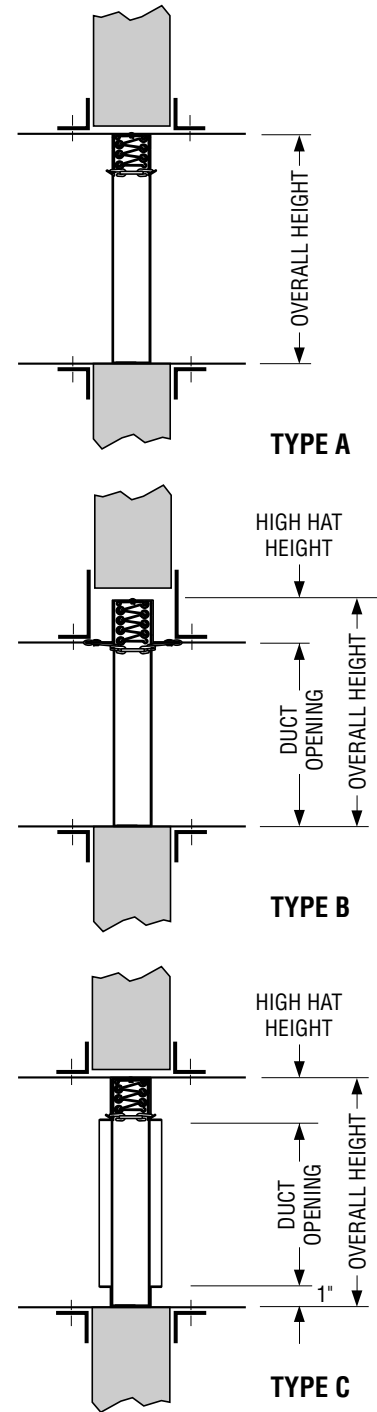
<b>SCHEDULE TYPE:</b>				
<b>PROJECT:</b>				
<b>ENGINEER:</b>	<b>DATE</b>	<b>B SERIES</b>	<b>SUPERSEDES</b>	<b>DRAWING NO.</b>
<b>CONTRACTOR:</b>	4 - 28 - 14	FD	3 - 1 - 05	0570



**FIRE DAMPER SIZING CHART • IMPERIAL**  
**THINLINE FRAME (2" WIDE)**  
**MODEL SERIES 0210 – 0240, 0570 – 0590**

DUCT OPENING HEIGHT (inches)	TYPE "A" OVERALL HEIGHT (inches)	TYPE "B" OVERALL HEIGHT (inches)	TYPE "C" OVERALL HEIGHT (inches)
3		5 1/8	5 3/4
4	3 3/4	6 1/8	6 3/4
5	4 3/4	7 1/8	7 3/4
6	5 3/4	8 1/8	8 3/4
7	6 3/4	9 1/8	9 3/4
8	7 3/4	10 1/8	10 3/4
9	8 3/4	11 1/8	11 3/4
10	9 3/4	13 1/8	13 3/4
11	10 3/4	14 1/8	14 3/4
12	11 3/4	15 1/8	15 3/4
13	12 3/4	16 1/8	16 3/4
14	13 3/4	17 1/8	17 3/4
15	14 3/4	18 1/8	18 3/4
16	15 3/4	20 1/8	20 3/4
17	16 3/4	21 1/8	21 3/4
18	17 3/4	22 1/8	22 3/4
19	18 3/4	23 1/8	23 3/4
20	19 3/4	25 1/8	25 3/4
21	20 3/4	26 1/8	26 3/4
22	21 3/4	27 1/8	27 3/4
23	22 3/4	28 1/8	28 3/4
24	23 3/4	29 1/8	29 3/4
25	24 3/4	30 1/8	30 3/4
26	25 3/4	32 1/8	32 3/4
27	26 3/4	33 1/8	33 3/4
28	27 3/4	34 1/8	34 3/4
29	28 3/4	35 1/8	35 3/4
30	29 3/4	36 1/8	36 3/4
31	30 3/4	37 1/8	37 3/4
32	31 3/4	39 1/8	39 3/4
33	32 3/4	40 1/8	40 3/4
34	33 3/4	41 1/8	41 3/4
35	34 3/4	43 1/8	43 3/4
36	35 3/4	44 1/8	44 3/4
37	36 3/4	45 1/8	45 3/4
38	37 3/4	46 1/8	46 3/4
39	38 3/4	47 1/8	47 3/4
40	39 3/4	48 1/8	48 3/4
41	40 3/4	50 1/8	50 3/4
42	41 3/4	51 1/8	51 3/4
43	42 3/4	52 1/8	52 3/4
44	43 3/4	53 1/8	53 3/4
45	44 3/4	54 1/8	54 3/4
46	45 3/4	55 1/8	55 3/4
47	46 3/4	57 1/8	57 3/4
48	47 3/4	58 1/8	58 3/4
49	48 3/4	59 1/8	59 3/4
50	49 3/4	60 1/8	
51	50 3/4		
52	51 3/4		
53	52 3/4		
54	53 3/4		
55	54 3/4		
56	55 3/4		
57	56 3/4		
58	57 3/4		
59	58 3/4		
60	59 3/4		

**DAMPER WIDTH OVERALL**  
 Type "A" = Duct Opening - 1/4".  
 Type "B" = Duct Opening - 1/4".  
 Type "C" = Duct Opening + 1 3/4".



Dimensions are in inches (mm).

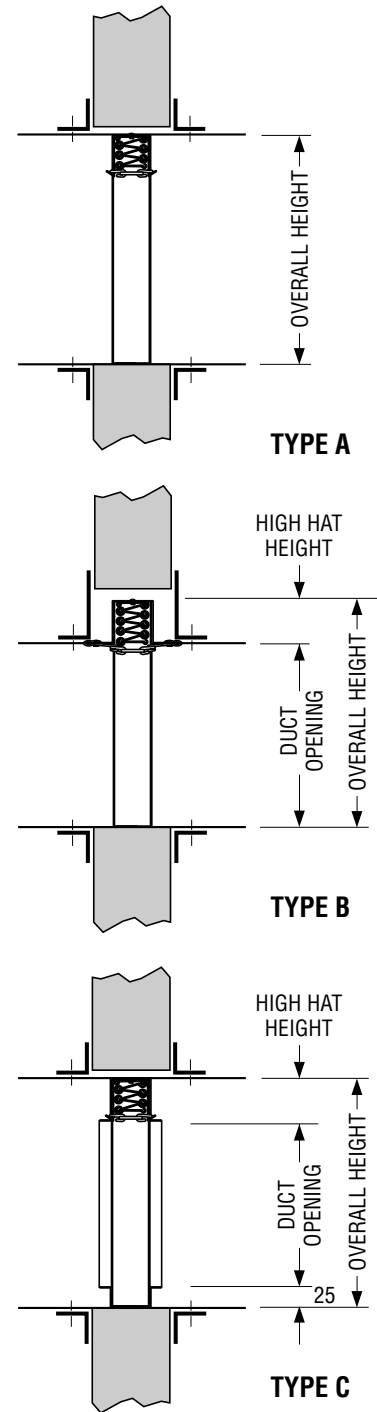
<b>SCHEDULE TYPE:</b>
<b>PROJECT:</b>
<b>ENGINEER:</b>
<b>CONTRACTOR:</b>

<b>DATE</b>	<b>B SERIES</b>	<b>SUPERSEDES</b>	<b>DRAWING NO.</b>
11 - 10 - 00R	FD	8-90/0200-3A	SC3



**FIRE DAMPER SIZING CHART • METRIC**  
**THINLINE FRAME (51 MM WIDE)**  
**MODEL SERIES 0210 – 0240, 0570 – 0590**

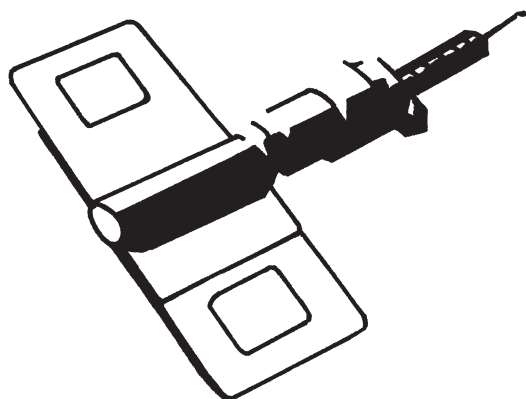
DUCT OPENING HEIGHT (mm)	TYPE "A" OVERALL HEIGHT (mm)	TYPE "B" OVERALL HEIGHT (mm)	TYPE "C" OVERALL HEIGHT (mm)
76		130	146
102	95	156	171
127	121	181	197
152	146	206	222
178	171	232	248
203	197	257	273
229	222	283	298
254	248	333	349
279	273	359	375
305	298	384	400
330	324	410	425
356	349	435	451
381	375	460	476
406	400	511	527
432	425	537	552
457	451	562	578
483	476	587	603
508	502	638	654
534	527	664	679
559	552	689	705
584	578	714	730
610	603	740	756
635	629	765	781
661	654	816	832
656	679	841	857
711	705	867	883
737	730	892	908
762	756	918	933
787	781	943	959
813	806	994	1010
838	832	1019	1035
864	857	1045	1060
889	883	1095	1111
914	908	1121	1137
940	933	1146	1162
965	959	1172	1187
991	984	1197	1213
1016	1010	1222	1238
1041	1035	1273	1289
1067	1060	1299	1314
1092	1086	1324	1340
1117	1111	1349	1365
1143	1137	1375	1391
1168	1162	1400	1416
1194	1187	1451	1467
1219	1213	1476	1492
1245	1238	1502	1518
1270	1264	1527	
1296	1289	<b>DAMPER WIDTH OVERALL</b> Type "A" = Duct Opening - 6. Type "B" = Duct Opening - 6. Type "C" = Duct Opening + 44.	
1321	1314		
1346	1340		
1372	1365		
1397	1391		
1423	1416		
1448	1441		
1473	1467		
1499	1492		
1524	1518		



Dimensions are in inches (mm).

<b>SCHEDULE TYPE:</b>
<b>PROJECT:</b>
<b>ENGINEER:</b>
<b>CONTRACTOR:</b>

<b>DATE</b>	<b>B SERIES</b>	<b>SUPERSEDES</b>	<b>DRAWING NO.</b>
11 - 10 - 00R	FD	NEW	SC4



## ETL®

### WHAT IT IS – WHAT IT DOES

The Electro Thermal Link (ETL®) is a multi purpose, dual responsive fusible link which reacts (melts) when subjected to;

1. Local heat (165°F (74°C)) exactly the same as an ordinary link.
2. External electrical impulse of low power and short duration.

It is specifically designed to substitute for ordinary links and/or actuators in existing and new installations of Fire Dampers, Fire Doors, Fire Extinguishers, Fire and Smoke Roof Hatches, Sprinklers, Smoke Towers, and chemical or gas Automatic Release Systems.

The substitution should be made in every installation of the above devices where it is desirable to improve life safety by making those devices responsive to -

- SMOKE** in the early form of invisible products of combustion through ionization detectors, or
- FIRE** at an earlier stage than ordinary links thru the use of rate of rise or maximum temperature devices.

The ETL's electro-response is the unique feature. It is not smoke responsive of itself, but its power requirement is so low that it can be released with an electrical impulse from any smoke detector's power source. It is compatible with every smoke detector on the market in the United States today.

The operating range is 6 to 30 volts AC or DC, less than 0.2 ampere of trip current required, and 1/2 millisecond (.0005 second) response at 24 v. The electrical response is a trigger for the chemical heating of the center element which is a self-contained exothermic reactor, yielding no noise, smoke, or gas - just quick heat to open the link in seven seconds.

The ETL's thermal response is identical to that of ordinary fusible links of identical temperature (165°F (74°C)) and strength (40#) rating.

In its capacity of converting a FIRE safety device into a FIRE/SMOKE safety device the ETL can be substituted for both an ordinary link and motor, or link and electromagnetic operator with advantages of simplicity, economy, operational reliability and wide acceptability. With its dual responsiveness the ETL can be substituted for two other devices at a savings in first cost as well as operating cost and maintenance. The ETL is a Space Age Device built to zero defect standards and to last at least fifty years and then still react properly – only on fire or smoke emergency. It is totally independent of power failures since it draws power from the detector standby source if needed. The ETL is listed by Underwriter's Laboratories, Inc. as a Fusible Link.

With the ongoing development of dynamic smoke control systems and building code changes in recent years, application and use of this product should be governed by acceptance of the local authority having jurisdiction.

<b>SCHEDULE TYPE:</b>		Dimensions are in inches (mm).			
<b>PROJECT:</b>					
<b>ENGINEER:</b>	<b>DATE</b>	<b>B SERIES</b>	<b>SUPERSEDES</b>	<b>DRAWING NO.</b>	
<b>CONTRACTOR:</b>	31 - 7 - 00R	ACC	1 - 98R/0100-6	ACC.ETL	

**"QUICK-SET" RETAINING ANGLES BOTH SIMPLIFY AND SPEED INSTALLATION,  
 SAVING BOTH TIME AND MONEY.**

**BENEFITS:**

- One piece angles are fastened together in the corners. Only two sets of angles to handle per damper (rather than four separate angles per side).
- Angles are shipped with damper - no sorting or matching.
- Provided with pre-drilled fastening holes on 2" (51) centers to ensure correct angle/sleeve attachment.
- Factory fabricated by Nailor to suit the individual fire damper.
- Reduced cost when compared to conventional retaining angles.
- Dampers can ship directly to the job site complete with all necessary installation sheet metal hardware (saves on double handling at contractor's shop).
- Help ensure a correct installation as per U.L. approved installation instructions.

The majority of installing contractors view fire damper installation as a costly time consuming and troublesome procedure. Eight conventional angles must be custom fabricated for each damper either in a sheet metal shop or at the job site and sized to suit each individual damper. Invariably, they are mislaid or lost and must be matched to each factory supplied damper.

The Nailor "Quick-Set" solution solves the majority of problems. They are pre-formed to fit and ship with the individual damper for ultimate convenience. "Quick-Set" angles are supplied with correctly spaced pre-drilled screw-holes to ensure a quick, easy and accurate installation for all integral sleeve Nailor fire and combination fire/smoke dampers - no measuring required.

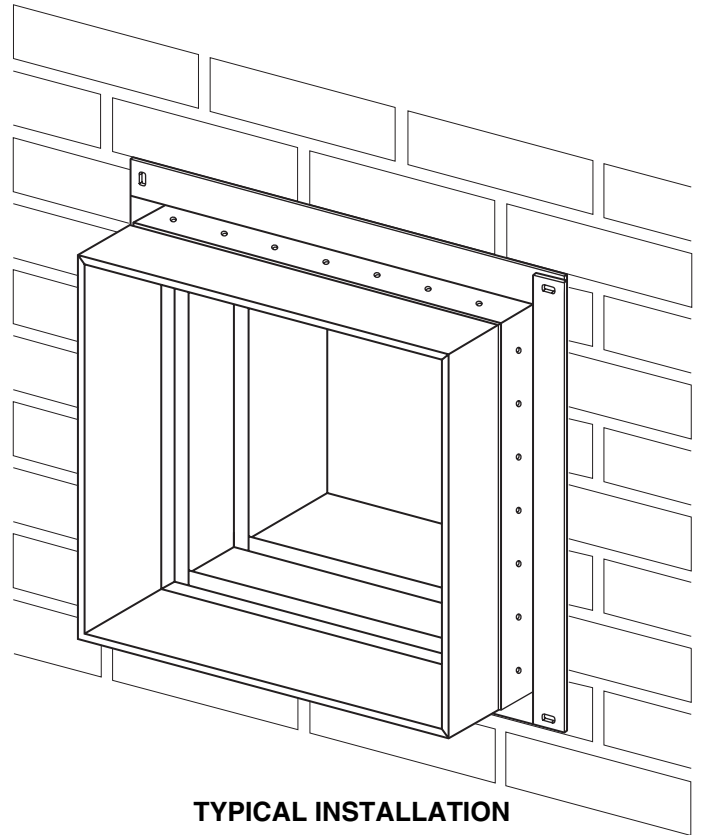
"Quick-Set" retaining angles provide the "complete" installation package. Simple, fast, convenient.

**MODELS:**

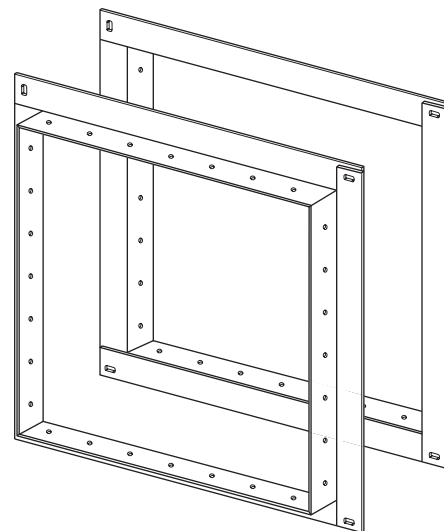
Nailor "Quick-Set" retaining angles are an accessory option for all dampers ordered with factory sleeves.

**QS2:** Two sides (pair). For standard installations where angles are installed on both sides of the fire partition.

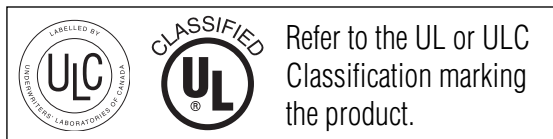
**QS1:** One side (single set). For use in single side retaining angle installations and with grille mount and "out of wall" damper models.



**TYPICAL INSTALLATION**



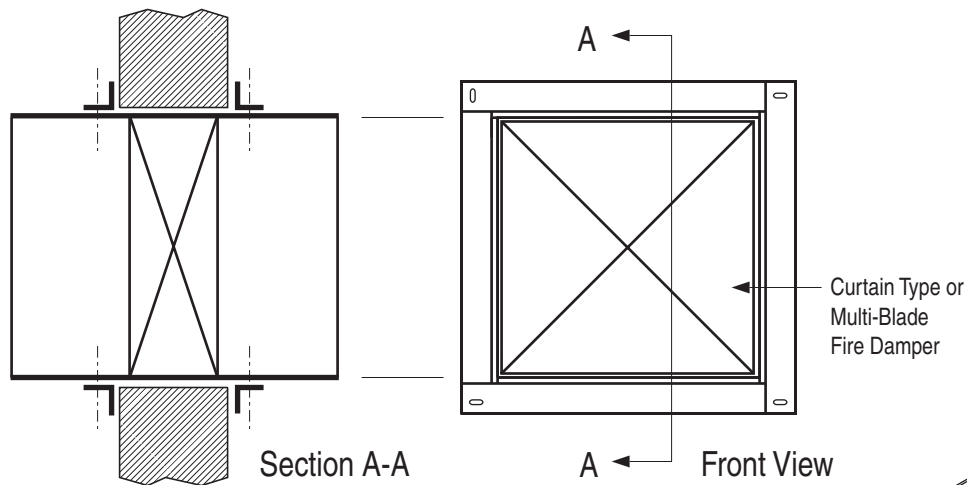
**TYPICAL PAIR OF PRE-ASSEMBLED  
 QUICK-SET' RETAINING ANGLES**



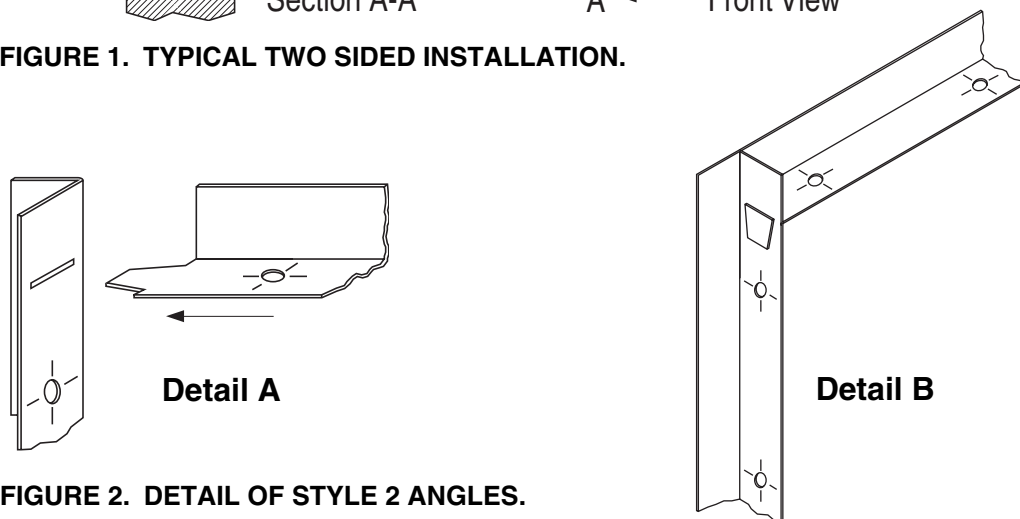
<b>SCHEDULE TYPE:</b>
<b>PROJECT:</b>
<b>ENGINEER:</b>
<b>CONTRACTOR:</b>

Page 1 of 2 Dimensions are in inches (mm).			
<b>DATE</b>	<b>B SERIES</b>	<b>SUPERSEDES</b>	<b>DRAWING NO.</b>
2 - 26 - 09	FD-ACC	6 - 5 - 03	QSRA

**"QUICK-SET" RETAINING ANGLES**  
**FOR ALL SLEEVED FIRE AND**  
**COMBINATION FIRE/SMOKE DAMPERS**  
**MODELS: QS1 AND QS2**



**FIGURE 1. TYPICAL TWO SIDED INSTALLATION.**



**FIGURE 2. DETAIL OF STYLE 2 ANGLES.**

**APPLICATION:**

The Nailor Quick-Set Retaining Angle System may be used in lieu of conventional retaining angles on all Nailor Fire and Combination Fire/Smoke Dampers.

Quick-Set angles are supplied in one of two styles, dependent upon fire resistance label, damper size and installation method.

**Style 1:** 1 1/2" x 1 1/2" x 20 ga. (38 x 38 x 1.0) Four sides are connected together with rivets in three corners.

Standard for the majority of applications with the following limitations:

- 1 1/2 hour label fire dampers.
- Maximum Size: 36" x 36" (914 x 914)
- Two sided installation only

**Style 2:** 1 1/2" x 1 1/2" x 16 ga. (38 x 38 x 1.6) Slot and tab design. The retaining angle assembly for each side has four angles, each with a tab end and a slot end (Detail A).

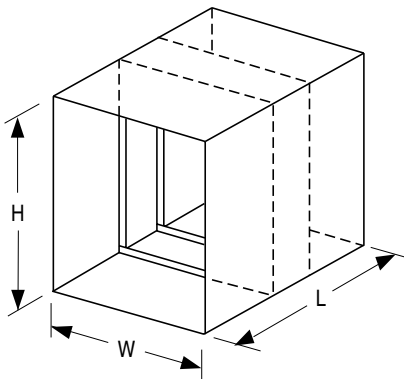
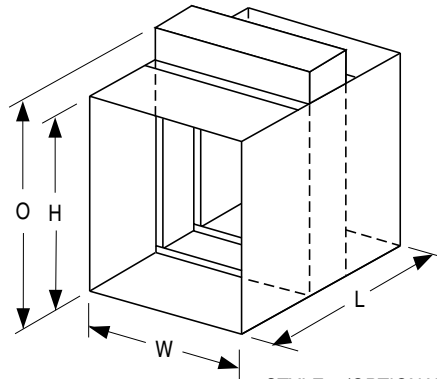
The tabs are to be inserted into the slots and knocked down either before or after fastening to the sleeve (Detail B).

- 1 1/2 or 3 hour label fire dampers
- Maximum Size: 90" x 48" (2286 x 1219) or 48" x 90" (1219 x 2286)
- Single side (1 1/2 hour only. Refer to Single Side Retaining Angles Supplementary Installation Instructions for size limitations) or two sided installation

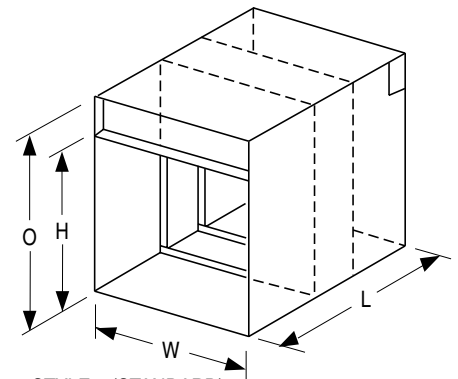
**Refer to the Following Installation Instructions:**

Quick-Set Retaining Angles	FDQSRA
Curtain Type Fire Dampers (D)0100 & (D)0500	FDINST
Curtain Type Fire Dampers 0200 & 0500 Thinline	FDTINST
Multi-Blade Fire Dampers 1200 & 1250	MBFDINST
Combination Fire/Smoke Dampers 1220	1220INST
Combination Fire/Smoke Dampers 1270	1270INST
Single Side Retaining Angles	FDSSRAINST

<b>SCHEDULE TYPE:</b>	Page 2 of 2			
<b>PROJECT:</b>	Dimensions are in inches (mm).			
<b>ENGINEER:</b>	<b>DATE</b>	<b>B SERIES</b>	<b>SUPERSEDES</b>	<b>DRAWING NO.</b>
<b>CONTRACTOR:</b>	2 - 26 - 09	FD-ACC	5 - 5 - 03	QSRA


**TYPE 'A'**
**BLADES AND FRAME IN AIRSTREAM**


STYLE 1 (OPTIONAL)



STYLE 2 (STANDARD)

**TYPE 'B' BLADES OUT OF AIRSTREAM**
**NOTES:**
**1. Dimensional Data.**

W = Nominal duct width

H = Nominal duct height

L = Sleeve length

O = Overall damper height

For 'O' dimension and relationship to duct height, refer to dwgs. SC1/SC2 (standard frame) or SC3/SC4 (thinline frame) depending on damper model.

Type CR duct collars are furnished 1/8" (3) undersize for duct dimensions up to 36" dia. (914) and 1/4" (6) undersize on larger sizes.

Type CO and CSR duct collars are furnished 1/8" (3) undersize for duct dimensions up to 36" x 24" (914 x 610) and 1/4" (6) undersize on larger sizes. Collars are 1 1/4" (32) minimum length.

**2.** Sleeves are available in lengths up to 36" (914) and in 10 through 22 gauge (3.51 through 0.85) galvanized steel as required for application.

Standard sleeve is 12" (305) long x 20 gauge (1.01).

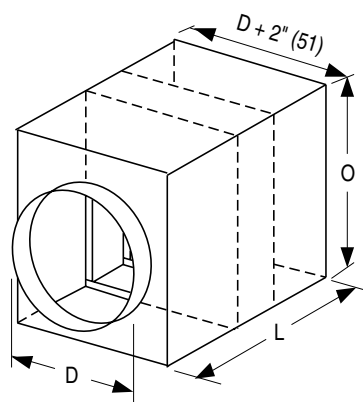
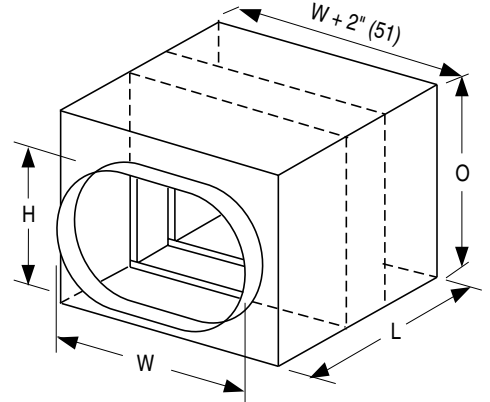
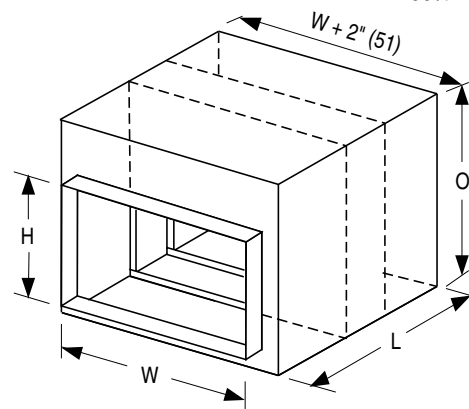
Sleeve gauge must conform to SMACNA Duct Construction Standards and shall not be less than the gauge of the duct to which it is attached for sleeves exposed to the airstream.

**3.** See individual models for minimum and maximum size limitations.

**4.** Dampers are centered in sleeve unless specified otherwise.

**5.** Multiple section damper assemblies are shipped knocked down for field assembly.

**Type CR, CO and CSR Option:**
 LP Unsealed. Suitable for low pressure systems.

 HP Sealed. Suitable for medium/high pressure systems. Externally caulked (up to 6" w.g./1.5 kPa).

**TYPE 'CR'**  
**ROUND TRANSITION COLLARS/DUCT.**  
**100% FREE AREA.**

**TYPE 'CO'**  
**FLAT OVAL TRANSITION COLLARS/DUCT.**  
**100% FREE AREA.**

**TYPE 'CSR'**  
**RECTANGULAR TRANSITION COLLARS/DUCT. 100% FREE AREA.**
**SCHEDULE TYPE:**
**PROJECT:**
**ENGINEER:**
**CONTRACTOR:**

Dimensions are in inches (mm).

**DATE**
**B SERIES**
**SUPERSEDES**
**DRAWING NO.**

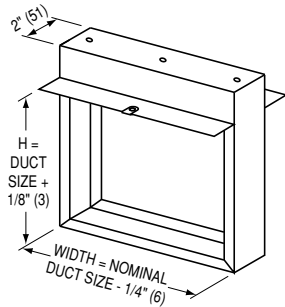
25 - 10 - 00R

FD

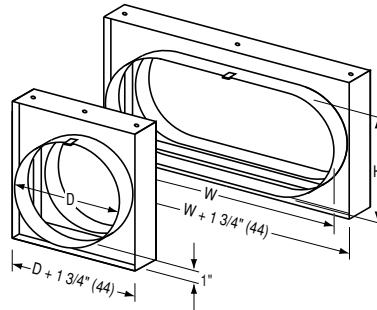
7-00/0100-14

STD-SL

## DIMENSIONAL DATA:

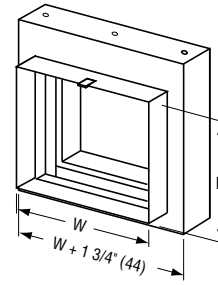


**MODEL 0580:  
TYPE B**

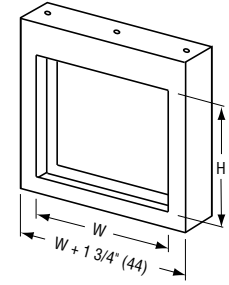


**MODEL 0590:  
TYPE CR**

**MODEL 0590:  
TYPE CO**



**MODEL 0590:  
TYPE CSR  
WITH COLLAR  
(STANDARD)**



**MODEL 0590:  
TYPE CSR  
WITHOUT COLLAR**

For overall damper dimensions see sizing chart on page D54.

## PERFORMANCE DATA:

### MODELS: 0570V, 0580V, 0590V - 3 HOUR LABEL

Curtain type fire dampers impose minimal resistance to air flow in the system. The following charts indicate both free area for the different damper types and static pressure losses for various velocities.

#### Type A Thinline Damper Free Area – sq. ft.

Duct Height in inches (mm)	Duct Width in inches (mm)							
	6" (152)	12" (305)	18" (457)	24" (610)	30" (762)	36" (914)	40" (1016)	
6" (152)	.12	.27	.44	.59	.75	.94	1.02	
12" (305)	.27	.61	.93	1.36	1.7	2.1	2.4	
18" (457)	.42	.94	1.5	2.2	2.7	3.4	3.7	
24" (610)	.55	1.29	2.1	3.0	3.7	4.5	4.9	
30" (762)	.71	1.65	2.6	3.8	4.3	5.7	6.3	
36" (914)	.86	2.1	3.2	4.6	5.7	7.0	7.7	
42" (1067)	.93	2.3	3.5	5.1	6.3	7.6	8.8	
48" (1219)	1.14	2.7	4.3	6.0	7.7	9.4	n/a	
54" (1372)	1.32	3.1	4.9	6.2	8.8	10.7	n/a	
60" (1524)	1.51	3.5	5.5	7.7	9.9	11.8	n/a	

#### Type B Thinline Damper Free Area – sq. ft.

Duct Height in inches (mm)	Duct Width in inches (mm)							
	6" (152)	12" (305)	18" (457)	24" (610)	30" (762)	36" (914)	40" (1016)	
6" (152)	.15	.32	.52	.69	.88	1.09	1.17	
12" (305)	.31	.70	1.07	1.55	1.95	2.4	2.7	
18" (457)	.47	1.05	1.7	2.5	3.05	3.8	4.2	
24" (610)	.62	1.44	2.3	3.4	4.2	5.1	5.6	
30" (762)	.80	1.84	2.9	4.3	4.9	6.5	7.2	
36" (914)	.95	2.33	3.6	5.1	6.4	7.8	n/a	
42" (1067)	1.0	2.5	3.8	5.6	7.0	8.5	n/a	
48" (1219)	1.3	3.1	4.8	6.8	8.6	10.4	n/a	

Type C Dampers have Free Area equal to Nominal Duct Area.

To calculate Free Area of round duct: Diameter<sup>2</sup> x .00545 = Free Area (sq ft.)

To determine pressure drop across open damper, calculate **free area velocity** as shown, find velocity on curve and read across for s.p. differential.

$$\text{Free Area Velocity (fpm)} = \frac{\text{cfm}}{\text{Free Area}}$$

Example:

1 – 36" x 36" Damper required for 14,000 cfm. (Type A)

$$\text{FAV} = \frac{14,000}{7 \text{ sq. ft.}} = 2000 \text{ fpm}$$

2000 fpm located on the 'A' curve shows a pressure drop of .12 in. wg.

cfm = cubic feet per minute

fpm = feet per minute velocity

S.P. = static pressure in inches water gauge

FAV = Free Area Velocity

Imperial System Shown

To convert to SI (metric) system:

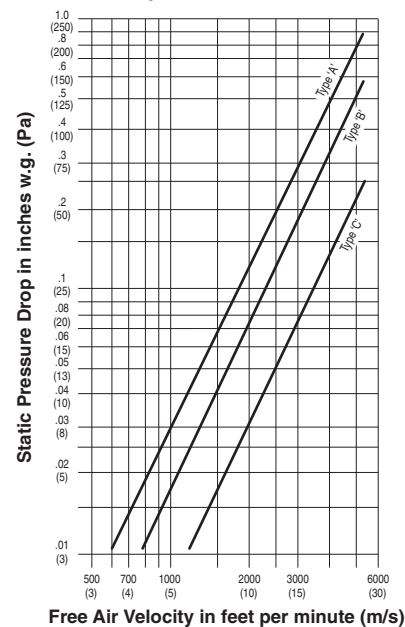
Multiply cfm by .4719 for liters per second

Multiply fpm by .00508 for meters per second

Multiply in. wg. by .2486 for kilopascals

Multiply sq. ft. by .0929 for square meters.

#### Pressure Drop





Dampers are an essential part of the fire protection system in a building. The NFPA recommends that fire dampers be tested periodically to verify the operational abilities of each installed damper. See NFPA 80, *Standard for Fire Doors and Other Opening Protectives*, for Operational Test and Periodic Inspection and Testing details.

**CAUTION:**

Some curtain fire dampers utilize high torque springs under tension; ensure HVAC fans are turned off. Testing spring assisted fire dampers under airflow conditions is **NOT RECOMMENDED** and may severely damage or destroy ductwork. Use protective eyewear or safety glasses. Keep hands out of the blade path, as this can cause serious injury. Keep any hard objects or tools out of the blade path as they can damage the blades when closing.

**Periodic Inspection, Testing and Maintenance**

Consult your local building code to verify whether there is a required maintenance and testing schedule. Most local jurisdictions reference NFPA 80 for Fire Dampers. Per NFPA 80, each damper should be tested and inspected 1 year after installation and then every 4 years, except for hospitals, where the frequency is every 6 years.

1. Remove any obstructions, dirt, rust, corrosion, or other observed conditions that could impede proper damper operation.
2. Check closure springs (if applicable). If damaged or defective, repair or replace.

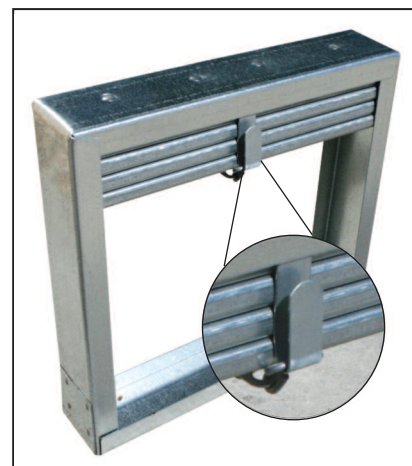
**3a. Non-Spring Assisted Dampers**

Bend metal straps away from damper frame so that they are straight. Remove fusible link and allow the blade package to drop and close naturally by the force of gravity. See Detail 1. Use caution, keeping fingers, hands, arms and tools out of the blade path.

**3b. Dynamic Rated or Spring Assisted Dampers**

**AS SOON AS THE LINK HAS BEEN REMOVED, THE SPRING WILL FORCE THE BLADES TO CLOSE INSTANTANEOUSLY. THE BLADE PATH MUST BE KEPT CLEAR.**

4. Ensure the damper closes completely, without assistance. If the damper design incorporates a locking ramp to hold the damper in the fully closed position, confirm that the ramp locks properly.
5. Clean damper blades and other moving parts if necessary. Use of a mild detergent or solvents is recommended for any cleaning required. Lubricate moving parts with a dry lubricant (such as T.F.E. Dry Lube). Never use a regular lubricating oil on dampers, as it will attract dirt and grit.
6. Lift the blade package to the top of the damper to reopen and replace the fusible link. Take care not to rack, deform or damage the blades when reopening.

**Detail 1**

**Reopening spring assisted fire dampers may be extremely difficult and in some cases, impossible.** If it is determined that the damper is impossible or impractical to test or reopen, a thorough examination of the blade path is required to ensure that nothing will prevent the damper from closing. Common obstructions include: racked damper frames, retaining angle installation screws, construction debris and contaminants.

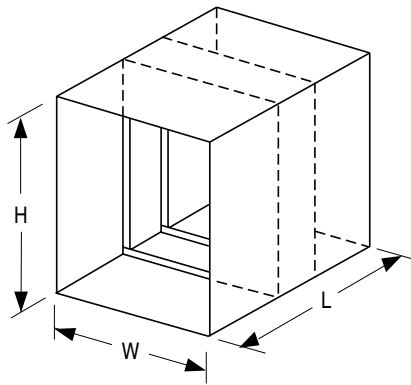
7. Slide the replacement fusible link onto the metal straps. When replacing the fusible link, make sure it is the same temperature rating of the link you are replacing. If a different temperature, contact factory. Install fusible link so that the temperature rating is facing outward and is visible.
8. Bend the metal straps up to hold the fusible link in place.

---

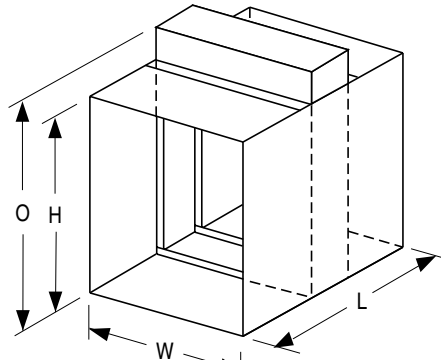
## Receiving, Storage, Preparation

Upon delivery, inspect shipping containers and contents closely. Note any damages on freight carrier's delivery receipt. Store dampers in a cool, dry and safe location in an orderly manner away from construction site, warehouse traffic, other materials, etc. Cover with plastic sheeting to protect from excessive moisture, dirt and debris.

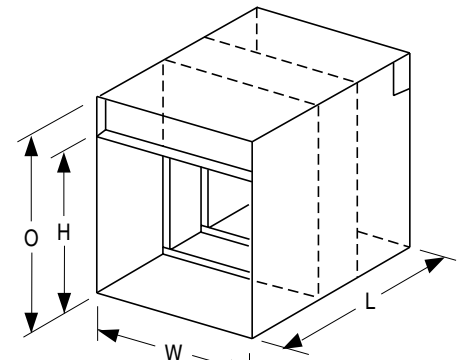
Inspect dampers prior to installation. Dampers must be cleaned per procedures outlined in this document prior to installation if dirt, rust or corrosion is observed.



**TYPE 'A'**  
BLADES AND FRAME IN AIRSTREAM



STYLE 1 (OPTIONAL)



STYLE 2 (STANDARD)

**TYPE 'B' BLADES OUT OF AIRSTREAM**

**NOTES:**

**1. Dimensional Data.**

- W = Nominal duct width
- H = Nominal duct height
- L = Sleeve length
- O = Overall damper height

For 'O' dimension and relationship to duct height, refer to dwgs. FDSC (standard frame) or FDTSC (thinline frame) depending on damper model.

Type CR duct collars are furnished 1/8" (3) undersize for duct dimensions up to 36" dia. (914) and 1/4" (6) undersize on larger sizes.

Type CO and CSR duct collars are furnished 1/8" (3) undersize for duct dimensions up to 36" x 24" (914 x 610) and 1/4" (6) undersize on larger sizes. Collars are 1 1/4" (32) minimum length.

- 2. Sleeves are available in lengths up to 36" (914) and in 10 through 22 gauge (3.51 through 0.85) galvanized steel as required for application.

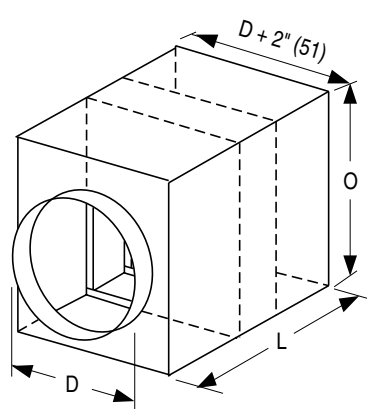
Standard sleeve is 12" (305) long x 20 gauge (1.01).

Sleeve gauge must conform to SMACNA Duct Construction Standards and shall not be less than the gauge of the duct to which it is attached for sleeves exposed to the airstream.

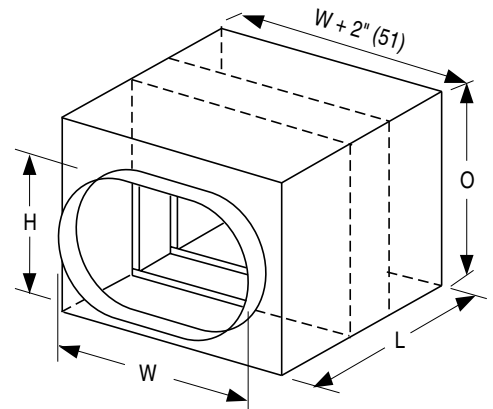
- 3. See individual models for minimum and maximum size limitations.
- 4. Dampers are centered in sleeve unless specified otherwise.
- 5. Multiple section damper assemblies are shipped knocked down for field assembly.

**Type CR, CO and CSR Option:**

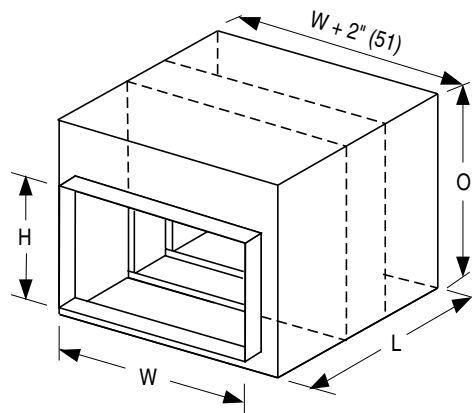
- LP Unsealed. Suitable for low pressure systems.
- HP Sealed. Suitable for medium/high pressure systems. Externally caulked (up to 6" w.g./1.5 kPa).



**TYPE 'CR'**  
ROUND TRANSITION COLLARS/DUCT.  
100% FREE AREA.



**TYPE 'CO'**  
FLAT OVAL TRANSITION COLLARS/DUCT.  
100% FREE AREA.



**TYPE 'CSR'**  
RECTANGULAR TRANSITION COLLARS/DUCT. 100% FREE AREA.

Dimensions are in inches (mm).



**Houston, Texas**  
Tel: 281-590-1172  
Fax: 281-590-3086

**Ft. Lauderdale, Florida**  
Tel: 954-351-2444  
Fax: 954-351-2440

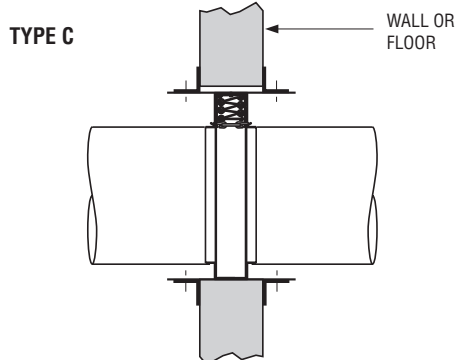
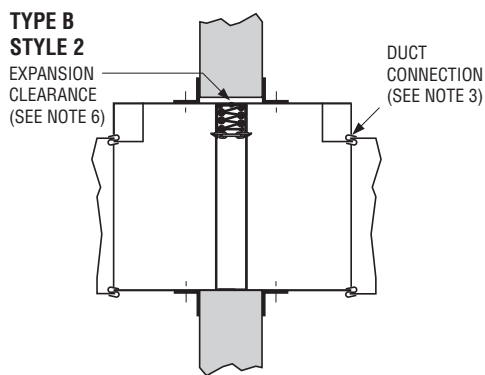
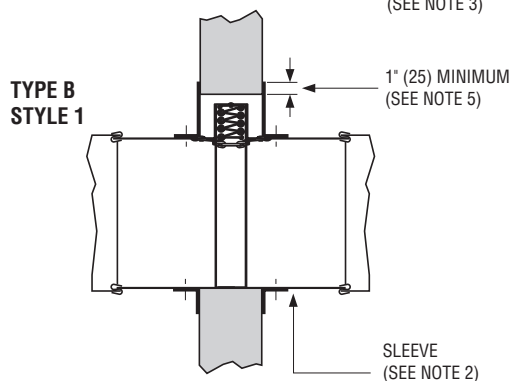
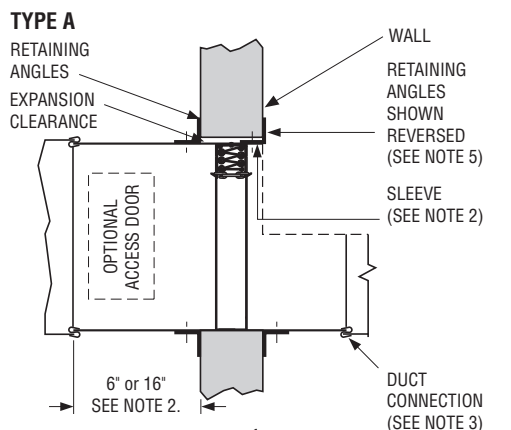
**Toronto, Canada**  
Tel: 416-744-3300  
Fax: 416-744-3360

**Calgary, Canada**  
Tel: 403-279-8619  
Fax: 403-279-5035

## INSTALLATION INSTRUCTIONS

### CURTAIN TYPE FIRE DAMPERS • THINLINE FRAME

MODELS: 0210 - 0240 (1 1/2 HR. LABEL, V OR H MOUNT)  
AND 0570 - 0590 (3 HR. LABEL, VERTICAL MOUNT ONLY)



#### QUALIFICATIONS:

- Meets all the requirements of UL 555.
- CAN/ULC-S112 Fire Damper Assemblies.
- Meets the requirements for BOCA, SBCCI, UBC, IBC, NBC (Canada) and associated local building codes.
- California State Fire Marshal Listing No. 03225-0935:100.
- City of New York Board of Standards and Appeals. Cal. No. 460-88-SA.



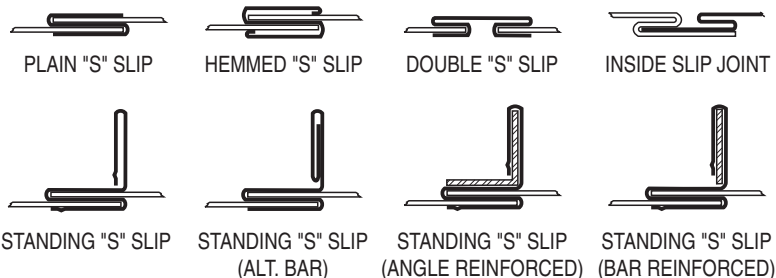
#### NOTES:

1. Installation shall be in accordance with the appropriate requirements of the National Fire Protection Association Standard NFPA 90A latest edition.
2. **Damper Sleeve:** Sleeve thickness must be equal to or thicker than the duct connected to it. Sleeve gauge requirements are listed in the SMACNA Fire, Smoke and Radiation Damper Installation Guide for HVAC Systems and in NFPA 90A. If a break-away style duct/sleeve connection is not used, damper sleeves up to 36" wide by 24" (914 x 610) high of not less than 16 gauge (1.61) coated steel, or larger sleeves of not less than 14 gauge (1.99) thick coated steel may be attached to the duct with screws or other types of mechanical fasteners. The maximum sleeve thickness for such rigid joints is 10 gauge (3.51) for coated steel.

The connecting duct shall not be continuous thru the wall or floor opening but shall terminate at the sleeve. Sleeves shall extend a maximum of 6" (152) on either side of the wall or floor opening or 16" (406) on one side when incorporating a factory installed access door.

#### 3. Break-away duct/sleeve connections:

- a. Rectangular ducts must use one or more of the following connections if the gauge is less than the requirement in note 2 for rigid connections:



In addition:

- A maximum of two #10 sheet metal screws on each side and on the bottom, located in the center of the slip pocket and penetrating both sides of the slip pocket may be used.
- One of the above connections on the top and bottom joints with flat drive slip



connections on the side joints may be used for dampers up to 20" (508) in height.

- b. Round and oval duct may be attached to the round or oval collar which is part of the damper/sleeve in the following manner:

- Duct diameters 22" (559) and smaller must use three #10 sheet metal screws equally spaced around the circumference.
- Duct diameters over 22" (559) up to and including 36" (914) may use five #10 sheet metal screws equally spaced around the circumference.
- Duct diameters larger than 36" (914) wide or diameter may use eight #10 sheet metal screws equally spaced around the circumference.

Dimensions are in inches (mm).

**Note:** When optional sealing of these break-away connections is desired, the duct sealant shall be PA2084T Duct Sealant by Precision or water based DP1010 by Design Polymetrics.

c. For the use of approved alternative Ductmate or TDC/TDF break-away connections, refer to the supplements noted below.

**4. Damper/sleeve attachment:** Damper shall be secured to sleeve with 1/4" (6) long welds on both sides at 6" (152) on center, or 3/4" x 3/4" x 18 gauge (19 x 19 x 1.31) angles all around on both sides attached to the sleeve with #8 sheet metal screws, 3/16" (4.76) steel rivets or 1/4" (6.35) bolts and nuts at 6" (152) on center and a maximum of 2" (51) from the corners of the damper on all four sides. For field assembled sleeves, the inner dimensions of the sleeve shall be equal to the outer dimensions of the damper.

**5. Retaining angles** shall be a minimum of 1 1/2" x 1 1/2" x 16 gauge (38 x 38 x 1.61). Secure the retaining angles to the sleeve with 1/2" (12.7) long welds, 1/4" (6.35) dia. bolts and nuts, 3/16" (4.76) dia. steel rivets or #8 sheet metal screws 8" (203) on center and 2" (51) maximum from corner of sleeve on all four sides. The retaining angles must lap the structural opening by 1" (25.4) minimum. When the ductwork terminates at the wall or floor, the retaining angles may be turned inwards, providing the opening size is increased by an amount equal to twice the combined thickness of the angle and the height of the screw or bolthead to maintain the required expansion clearance. The retaining angles are not to be mechanically fastened at the corners.

**6. Expansion clearance** between the sleeve and wall or floor shall be a minimum of 1/8" per foot (3.18 per 305) of width or height of the sleeve. The maximum size of the opening shall be 2" (50.8) larger in either dimension than the allowable minimum size. For example; a sleeve dimension of 36" x 36" (914 x 914) shall have an opening size of 36 3/8" x 36 3/8" (924 x 924) minimum and 38 3/8" x 38 3/8" (975 x 975) maximum.

7. The maximum Type A fire damper sizes are as follows:

Model Series		Single Section *		
0200	Static	Vertical	(1 1/2 hr. label)	41" x 36" or 36" x 60" (1041 x 914 or 914 x 1524)
		Horizontal	(1 1/2 hr. label)	
0500	Static	Vertical only	(3 hr. label)	36" x 60" (914 x 1524)

\* Type B and C dampers have the same overall damper size but the connecting ducts are smaller due to the B or C enclosures. See Type B and Type C specification drawings for maximum duct sizes. Multiple section assemblies are not permitted.

8. In cases when the openings are larger than specified in note 7, a UL tested and qualified steel mullion must be provided between sections. (Refer to supplementary installation document FDSMINST).

**IMPORTANT:**

DO NOT CAST DAMPER IN PLACE.  
DO NOT FASTEN RETAINING ANGLES OR DAMPER DIRECTLY TO WALL OR FLOOR.  
DO NOT INSTALL DAMPER OUT OF SQUARE OR OUT OF FLAT.  
VERTICAL MOUNTING SHOWN ON MASONRY WALL.  
FOR INSTALLATION IN DRYWALL FRAMING, SEE DOC. FDSWSFINST.  
HORIZONTAL MOUNTING SIMILAR FOR MASONRY FLOOR.

**REFER TO THE APPROPRIATE NAILOR INSTALLATION SHEETS FOR THE FOLLOWING SPECIAL REQUIREMENTS:**

STEEL MULLION (for dampers in oversized wall openings)	FDSMINST
SINGLE SIDED RETAINING ANGLES	FDSSRAINST
STEEL AND WOOD STUD FRAMING	FDSWSFINST
CAVITY SHAFT WALL PARTITIONS	FDCSWINST
DUCTMATE BREAKAWAY CONNECTIONS	FDDMINST
TDC/TDF FLANGED DUCT CONNECTION	FDTDCFINST
QUICK-SET RETAINING ANGLES	FQQSRA



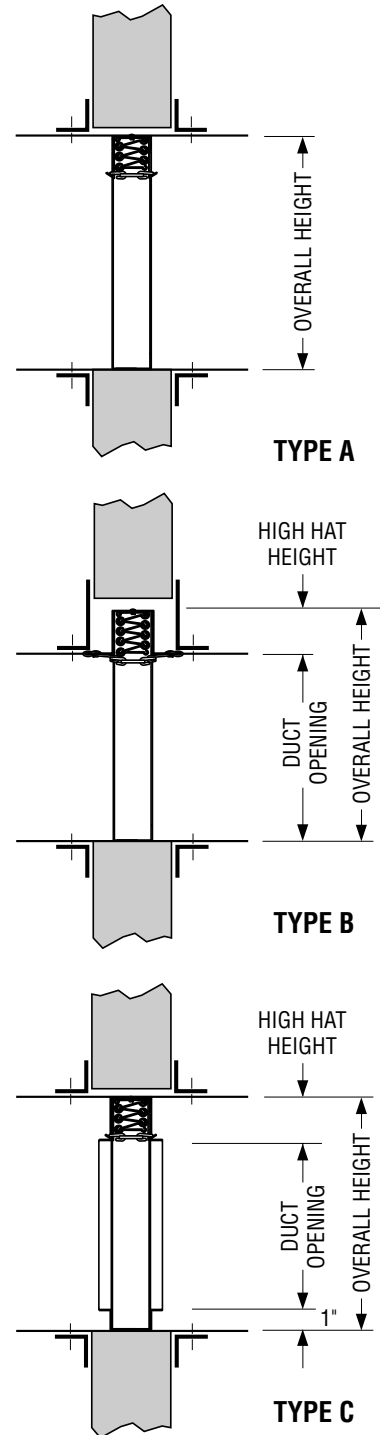
Houston, Texas  
Tel: 281-590-1172  
Fax: 281-590-3086

Las Vegas, Nevada  
Tel: 702-648-5400  
Fax: 702-638-0400

Toronto, Canada  
Tel: 416-744-3300  
Fax: 416-744-3360

Calgary, Canada  
Tel: 403-279-8619  
Fax: 403-279-5035

DUCT OPENING HEIGHT (inches)	TYPE "A" OVERALL HEIGHT (inches)	TYPE "B" OVERALL HEIGHT (inches)	TYPE "C" OVERALL HEIGHT (inches)
3		5 1/8	5 3/4
4	3 3/4	6 1/8	6 3/4
5	4 3/4	7 1/8	7 3/4
6	5 3/4	8 1/8	8 3/4
7	6 3/4	9 1/8	9 3/4
8	7 3/4	10 1/8	10 3/4
9	8 3/4	11 1/8	11 3/4
10	9 3/4	13 1/8	13 3/4
11	10 3/4	14 1/8	14 3/4
12	11 3/4	15 1/8	15 3/4
13	12 3/4	16 1/8	16 3/4
14	13 3/4	17 1/8	17 3/4
15	14 3/4	18 1/8	18 3/4
16	15 3/4	20 1/8	20 3/4
17	16 3/4	21 1/8	21 3/4
18	17 3/4	22 1/8	22 3/4
19	18 3/4	23 1/8	23 3/4
20	19 3/4	25 1/8	25 3/4
21	20 3/4	26 1/8	26 3/4
22	21 3/4	27 1/8	27 3/4
23	22 3/4	28 1/8	28 3/4
24	23 3/4	29 1/8	29 3/4
25	24 3/4	30 1/8	30 3/4
26	25 3/4	32 1/8	32 3/4
27	26 3/4	33 1/8	33 3/4
28	27 3/4	34 1/8	34 3/4
29	28 3/4	35 1/8	35 3/4
30	29 3/4	36 1/8	36 3/4
31	30 3/4	37 1/8	37 3/4
32	31 3/4	39 1/8	39 3/4
33	32 3/4	40 1/8	40 3/4
34	33 3/4	41 1/8	41 3/4
35	34 3/4	43 1/8	43 3/4
36	35 3/4	44 1/8	44 3/4
37	36 3/4	45 1/8	45 3/4
38	37 3/4	46 1/8	46 3/4
39	38 3/4	47 1/8	47 3/4
40	39 3/4	48 1/8	48 3/4
41	40 3/4	50 1/8	50 3/4
42	41 3/4	51 1/8	51 3/4
43	42 3/4	52 1/8	52 3/4
44	43 3/4	53 1/8	53 3/4
45	44 3/4	54 1/8	54 3/4
46	45 3/4	55 1/8	55 3/4
47	46 3/4	57 1/8	57 3/4
48	47 3/4	58 1/8	58 3/4
49	48 3/4	59 1/8	59 3/4
50	49 3/4	60 1/8	
51	50 3/4	<b>DAMPER WIDTH OVERALL</b> Type "A" = Duct Opening - 1/4". Type "B" = Duct Opening - 1/4". Type "C" = Duct Opening + 1 3/4".	
52	51 3/4		
53	52 3/4		
54	53 3/4		
55	54 3/4		
56	55 3/4		
57	56 3/4		
58	57 3/4		
59	58 3/4		
60	59 3/4		



Dimensions are in inches (mm).



**Houston, Texas**  
Tel: 281-590-1172  
Fax: 281-590-3086

**Ft. Lauderdale, Florida**  
Tel: 954-351-2444  
Fax: 954-351-2440

**Toronto, Canada**  
Tel: 416-744-3300  
Fax: 416-744-3360

**Calgary, Canada**  
Tel: 403-279-8619  
Fax: 403-279-5035



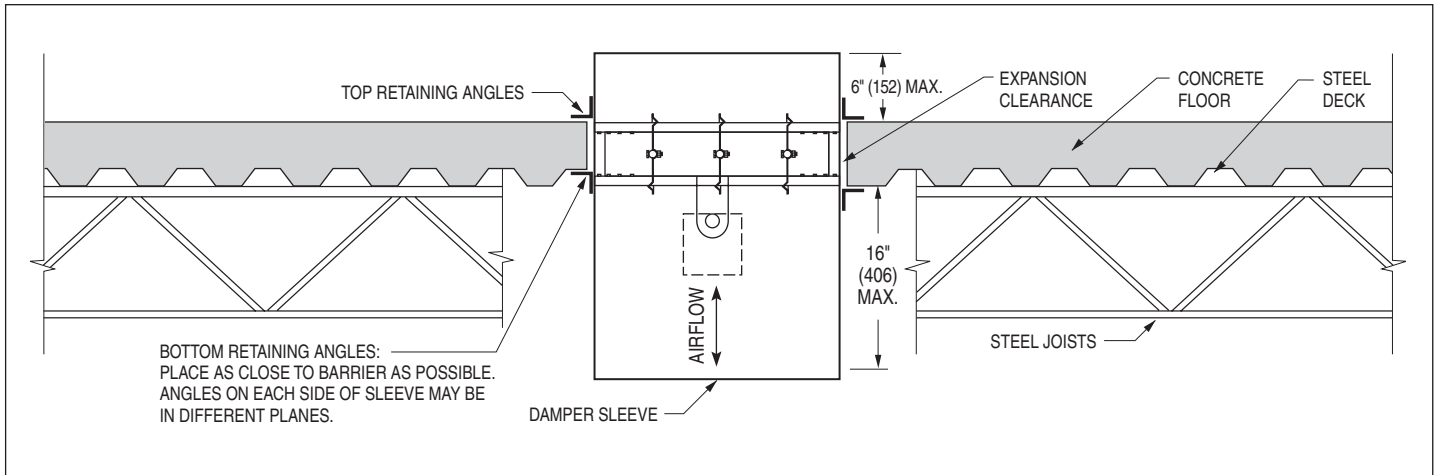


Fig. 1. Floor Opening Detail.

**APPLICATION:**

Horizontal installation of fire and combination fire/smoke dampers in concrete floors utilizing a steel deck may not allow the bottom angles to be placed against the steel deck on an even plane. This installation details how to properly install the required angles next to the steel deck.

**NOTES:**

1. Retaining angles are required on top and bottom sides of the damper as detailed in the damper installation instructions for the specific model. Angles may be reversed so that one leg of the angle points into the floor opening provided the required clearance is maintained between angle leg fasteners and the floor opening.

**Important:** When positioning damper in floor and attaching retaining angles to sleeve, ensure fasteners clear and do not penetrate damper frame. Failure to do so may prevent correct damper operation or closure due to fouling of linkage or damper blades.

2. Installation of the bottom angle against the uneven steel deck shall be done so the angles on each side of the sleeve are as close to the barrier as possible. The angles may be in different planes relative to each other (see Figures 1 and 2).
3. When viewed from the end of the sleeve, the angles must overlap each other in the corners to prevent "see through".

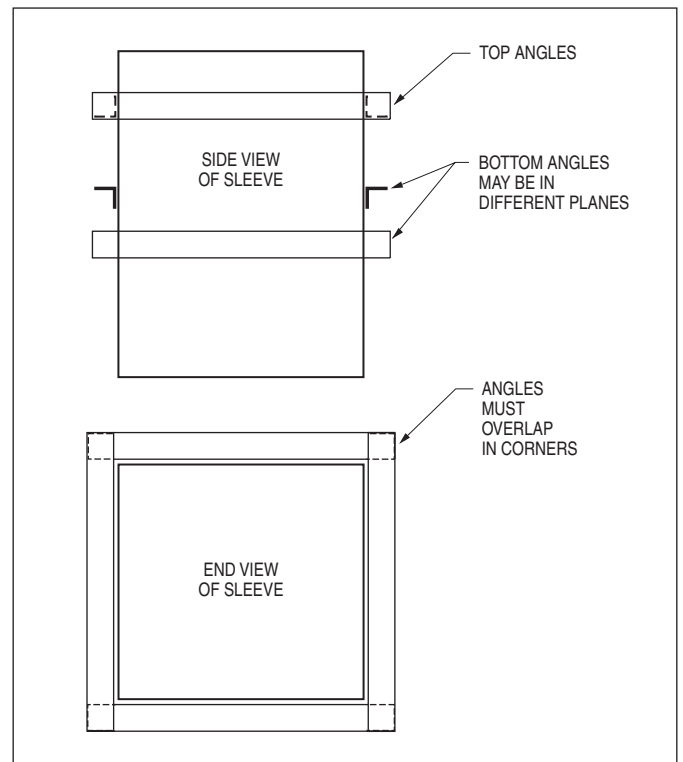


Fig. 2. Retaining Angle Detail

**Refer to the Following Installation Instructions:**

Curtain Type Fire Dampers (D)0100 & (D)0500	FDINST
Curtain Type Fire Dampers 0200 & 0500 Thinline	FDTINST
Multi-Blade Fire Dampers 1200 & 1250	MBFDINST
Combination Fire/Smoke Dampers 1220	1220INST
Combination Fire/Smoke Dampers 1270	1270INST



Dimensions are in inches (mm).



**Houston, Texas**  
Tel: 281-590-1172  
Fax: 281-590-3086

**Las Vegas, Nevada**  
Tel: 702-648-5400  
Fax: 702-638-0400

**Toronto, Canada**  
Tel: 416-744-3300  
Fax: 416-744-3360

**Calgary, Canada**  
Tel: 403-279-8619  
Fax: 403-279-5035

**APPLICATION:**

This vertical fire damper installation is for metal stud framing in UL resistant cavity shaft wall designs (1 and 2 hr.) including Nos. U438, U469 and U497. It differs from conventional fire damper installations in that it requires retaining angles on one side of the wall only, which are fastened to the wall as well as the damper for opening sizes up to 48" W x 36" H (1219 x 914). Larger openings require retaining angles on both sides.

**GENERAL INSTALLATION:**

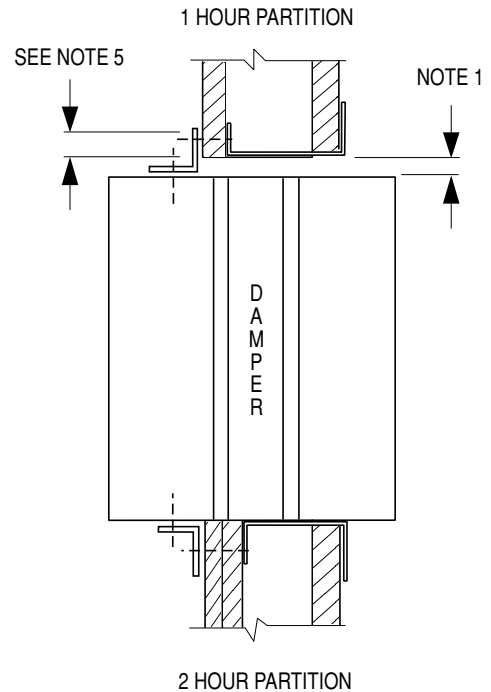
- 1. Expansion Clearance:** Opening in wall shall be a minimum 1/8" (3) per linear foot larger than overall size of damper and sleeve assembly in either dimension. Maximum opening not to exceed 1/8" (3) per foot plus two inches. Opening shall not be less than 1/4" (6) larger for any size damper and sleeve assembly.
- 2. Damper Sleeve:** Sleeve gauge shall be at least equal to the gauge of the duct as defined by the appropriate SMACNA duct construction standard and described in NFPA 90A when one or more of the following duct-sleeve connections are used (TDC/TDF breakaway, ductmate breakaway, plain "S" slip, hemmed "S" slip, standing "S" slip, reinforced standing "S" slip, inside slip joint, and double "S" slip.)

In addition, the following connections are acceptable:

- A.** On rectangular duct, a standing S slip connection, with two #10 sheet metal screws on each side and bottom of the joint and with duct sealant\* applied to each connection, may be used.
- B.** On rectangular duct, a standing S slip connection on top and bottom joints and flat drive connections on side joints with duct sealant\* applied to each connection, may be used for dampers 48" x 20" (1219 x 508) and smaller. Plain S and hemmed S slip connections can also be used in lieu of the standing S connections described above.
- C.** A round duct may be attached to the round adapter which is part of the damper sleeve in the following manner:
  - (a) Duct diameters 22" (559) and smaller must use three #10 sheet metal screws equally spaced around the circumference and with duct sealant\* applied to the connection.
  - (b) Duct diameters over 22" (559) up to and including 36" (914) may use five #10 sheet metal screws equally spaced around the circumference and with duct sealant\* applied to the connection.
  - (c) Duct diameters larger than 36" (914) wide or diameter may use eight #10 sheet metal screws equally spaced around the circumference.

\*The duct sealant must be PA2084T Duct Sealant Adhesive as manufactured by Precision or water based DP1010 by Design Polymetrics.

- 3.** If any other duct-sleeve connections are used, sleeve shall be minimum of 16 gauge (1.6) for dampers up to 36" w x 24"h (914 x 610) and 14 gauge (1.9) if damper width exceeds 36" (914) or height exceeds 24" (610).
- 4. Damper/Sleeve Attachment:** Damper shall be secured to sleeve with 1/4" (6) long welds, 3/16" (5) steel rivets, 1/4" (6) bolts and nuts, #8 sheet metal screws, or 3/16" (5) buttonlocks on both sides at 6" (152) on center and 2" (51) maximum from the corner of the damper on all four sides. For field assembled sleeves, the inner dimensions of the sleeve shall be equal to the outer dimensions of the damper.



**5. Retaining Angles:**

- A.** Shall be a minimum of 1 1/2" x 1 1/2" x 16 gauge (38 x 38 x 1.61) and fastened with #10 bolts or screws, 1/2" (13) long welds, or 3/16" (5) rivets to sleeve at a maximum spacing of 8" (152) O.C. and not more than 2" (51) from each end with a minimum of two connections on each side, top and bottom (See Illustration).

Nailor 'Quick-Set' Retaining Angles can be used in lieu of conventional mounting angles. Retaining angles must overlap the structural opening by 1" (25) minimum.

- B.** Retaining angles screw to wall with #10 screws. Use a minimum of two fasteners per side, top and bottom 12" (305) O.C. maximum.

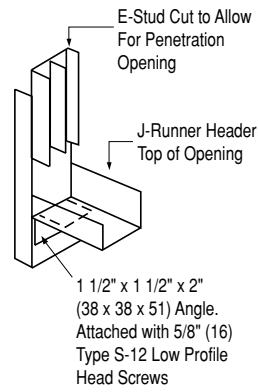
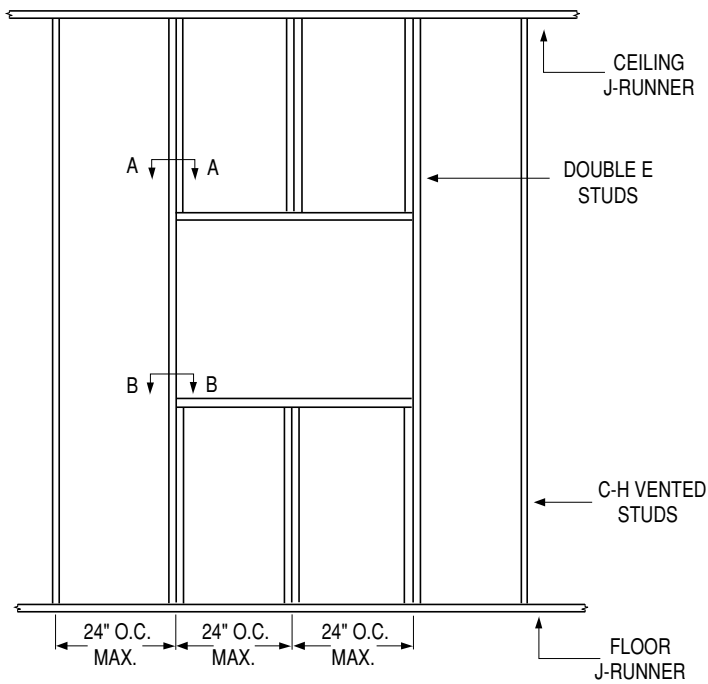
- 6.** See framing detail on next page for opening preparation. Refer to the appropriate installation supplements for the following requirements:

Ductmate Breakaway Connection	Doc. FDDMINST
Flange System Breakaway Connections	Doc. FDTDCFINST
'Quick-Set' Retaining Angles.	Doc. FDQSRA

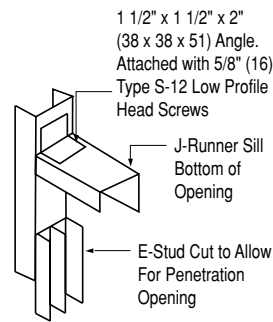
- 7.** Refer to Underwriters Laboratories Inc. Fire Resistance Directory Vol. II for details on UL Design No. U438, U469 and U497.



**FRAMING DETAIL FOR ASSEMBLIES  
(U438 AND U469)**

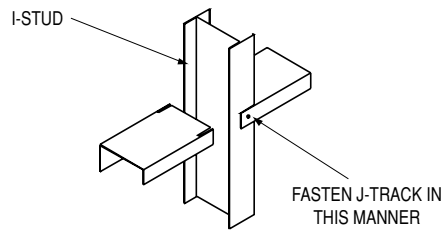
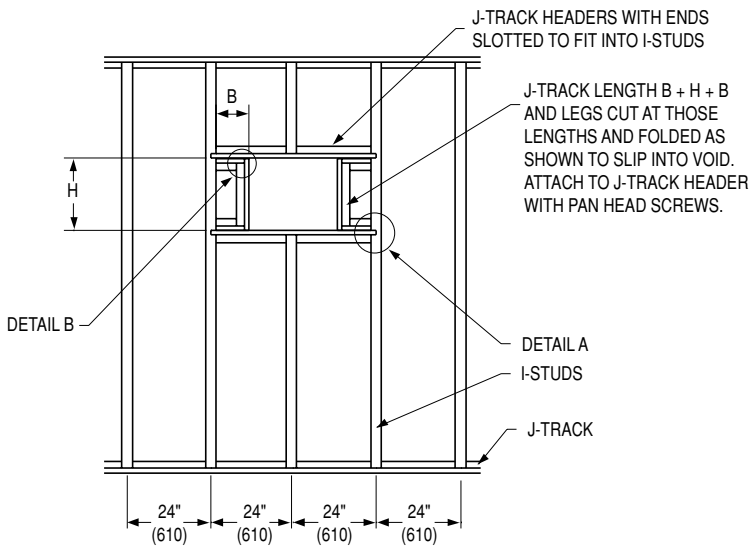


**SECTION A-A**

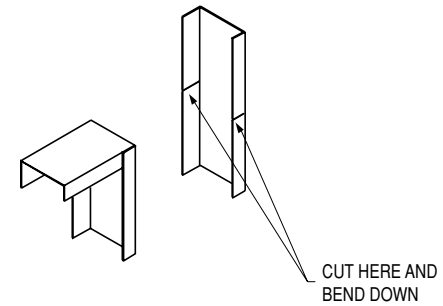


**SECTION B-B**

**FRAMING DETAIL FOR  
ASSEMBLIES (U497)**



**DETAIL A**



**DETAIL B**

Dimensions are in inches (mm).

Page 2 of 2

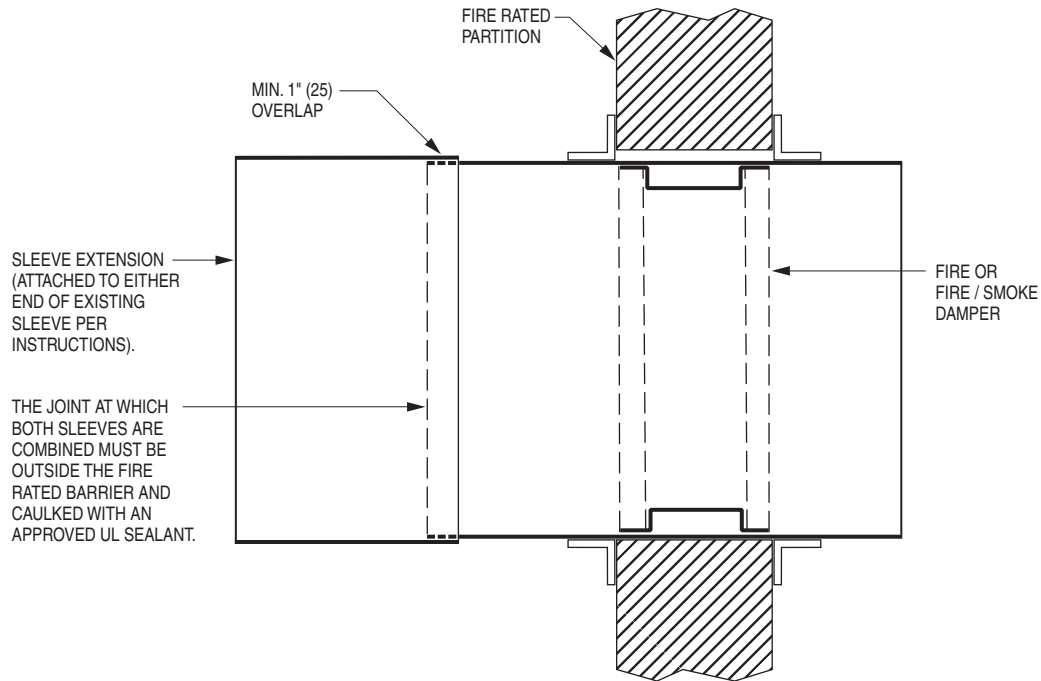


Houston, Texas  
Tel: 281-590-1172  
Fax: 281-590-3086

Las Vegas, Nevada  
Tel: 702-648-5400  
Fax: 702-638-0400

Toronto, Canada  
Tel: 416-744-3300  
Fax: 416-744-3360

Calgary, Canada  
Tel: 403-279-8619  
Fax: 403-279-5035



**Figure 1. Sleeve Extension Detail**

**APPLICATION:**

Factory installed sleeves may sometimes need to be extended in the field when of insufficient length for ductwork connection relative to the depth of the fire partition. This supplement installation instruction provides details for attachment of the sleeve extension. Consult Authority Having Jurisdiction for approval.

**NOTES (Refer to Figure 1):**

1. Sleeve extension must be same material and gauge as factory sleeve.
2. The inside dimensions of the sleeve extension must be the same dimensions as the outside dimensions of the factory sleeve.
3. Sleeve extension must overlap the factory sleeve a minimum of 1" (25).
4. All four sides of the sleeve extension must be attached to the factory sleeve. Attachments must be spaced a maximum of 6" (152) on center and a maximum of 2" (51) from corners. A minimum of 2 attachments per side (8 per damper) are required. Attach the sleeve extension using 1/2" (13) long tack or spot welds, #10 sheet metal screws, 1/4" (6.35) dia. bolts and nuts or 3/16" (5) steel pop rivets.
5. Products with a smoke leakage rating require that the joint between the two sleeves be sealed with a continuous 1/8" (3) bead of GE RTV108 or Dow Corning RTV732 silicone sealant.

6. Sleeve extensions can be made to either end of the factory sleeve. However, the sleeve cannot extend beyond the fire partition more than 6" (152) on either side or 16" (406) on one side if equipped with an actuator or integral access door.
7. The joint created by the factory sleeve and sleeve extension cannot be in the plane of the partition.

**Refer to the Following Installation Instructions:**

Curtain Type Fire Dampers (D)0100 & (D)0500	FDINST
Curtain Type Fire Dampers 0200 & 0500 Thinline	FDTINST
Multi-Blade Fire Dampers 1200 & 1250	MBFDINST
Combination Fire/Smoke Dampers 1220	1220INST
Combination Fire/Smoke Dampers 1270	1270INST



Dimensions are in inches (mm).

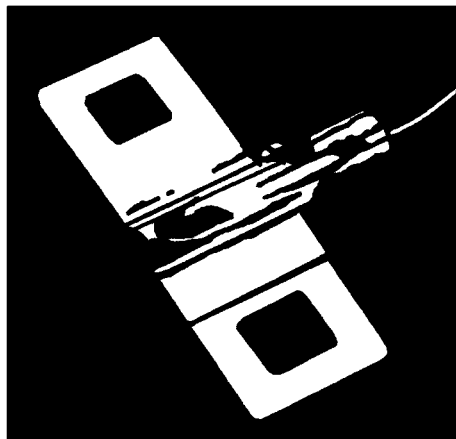
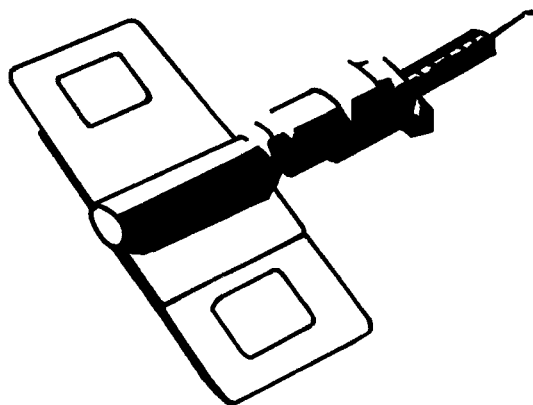


**Houston, Texas**  
Tel: 281-590-1172  
Fax: 281-590-3086

**Las Vegas, Nevada**  
Tel: 702-648-5400  
Fax: 702-638-0400

**Toronto, Canada**  
Tel: 416-744-3300  
Fax: 416-744-3360

**Calgary, Canada**  
Tel: 403-279-8619  
Fax: 403-279-5035



## ETL<sup>®</sup>

### WHAT IT IS – WHAT IT DOES

The Electro Thermal Link (ETL<sup>®</sup>) is a multi purpose, dual responsive fusible link which reacts (melts) when subjected to;

1. Local heat (165°F (74°C)) exactly the same as an ordinary link.
2. External electrical impulse of low power and short duration.

It is specifically designed to substitute for ordinary links and/or actuators in existing and new installations of Fire Dampers, Fire Doors, Fire Extinguishers, Fire and Smoke Roof Hatches, Sprinklers, Smoke Towers, and chemical or gas Automatic Release Systems.

The substitution should be made in every installation of the above devices where it is desirable to improve life safety by making those devices responsive to -

**SMOKE** in the early form of invisible products of combustion through ionization detectors, or  
**FIRE** at an earlier stage than ordinary links thru the use of rate of rise or maximum temperature devices.

The ETL's electro-response is the unique feature. It is not smoke responsive of itself, but its power requirement is so low that it can be released with an electrical impulse from any smoke detector's power source. It is compatible with every smoke detector on the market in the United States today.

The operating range is 6 to 30 volts AC or DC, less than 0.2 ampere of trip current required, and 1/2 millisecond (.0005 second) response at 24 v. The electrical response is a trigger for the chemical heating of the center element which is a self-contained exo-thermic reactor, yielding no noise, smoke, or gas - just quick heat to open the link in seven seconds.

The ETL's thermal response is identical to that of ordinary fusible links of identical temperature (165°F (74°C)) and strength (40#) rating.

In its capacity of converting a FIRE safety device into a FIRE/SMOKE safety device the ETL can be substituted for both an ordinary link and motor, or link and electromagnetic operator with advantages of simplicity, economy, operational reliability and wide acceptability. With its dual responsiveness the ETL can be substituted for two other devices at a savings in first cost as well as operating cost and maintenance. The ETL is a Space Age Device built to zero defect standards and to last at least fifty years and then still react properly – only on fire or smoke emergency. It is totally independent of power failures since it draws power from the detector standby source if needed. The ETL is listed by Underwriter's Laboratories, Inc. as a Fusible Link.

With the ongoing development of dynamic smoke control systems and building code changes in recent years, application and use of this product should be governed by acceptance of the local authority having jurisdiction.



**Houston, Texas**  
Tel: 281-590-1172  
Fax: 281-590-3086

**Ft. Lauderdale, Florida**  
Tel: 954-351-2444  
Fax: 954-351-2440

**Toronto, Canada**  
Tel: 416-744-3300  
Fax: 416-744-3360

**Calgary, Canada**  
Tel: 403-279-8619  
Fax: 403-279-5035



# Nailor<sup>®</sup> FIRE DAMPER INSTALLATION SUPPLEMENT Industries Inc. FLANGED TYPE ALTERNATE BREAKAWAY CONNECTIONS

These instructions provide details for an alternate breakaway connection between a fire damper or combination fire smoke damper sleeve and an adjoining duct. This alternate connection is classified with U.L. under the certification of the damper. These instructions apply to a connection using a manufactured add-on flange system by Ductmate, Ward, or Nexus and a TDC or TDF roll-formed flange system. These connections allow for both the use of the same flange type or the combining of mixed flange types. The following instructions depict the use of metal or plastic cleats and bolted or non-bolted corners:



1. Install the manufactured flange system onto the damper sleeve or duct per the manufacturer's instructions.
2. To seal the two flange systems together, Neoprene or Butyl gasketing may be applied between the mating surfaces.
3. Align the two flange systems together. An optional 3/8" (9) bolt may be used in the corners to help with the alignment. These bolts do not have to be removed.
4. Install the cleat or #10 tek screw approximately equally spaced, per the following schedule:
  - Width or height less than 24" (610); use one cleat or screw per side
  - Width or height 24" (610) to less than 36" (914); use 2 cleats or screws per side
  - Width or height 36" (914) to less than 54" (1372); use 3 cleats or screws per side
  - Width or height 54" (1372) to less than 72" (1829); use 4 cleats or screws per side
  - Width or height 72" (1829) or greater; use 5 cleats or screws per side

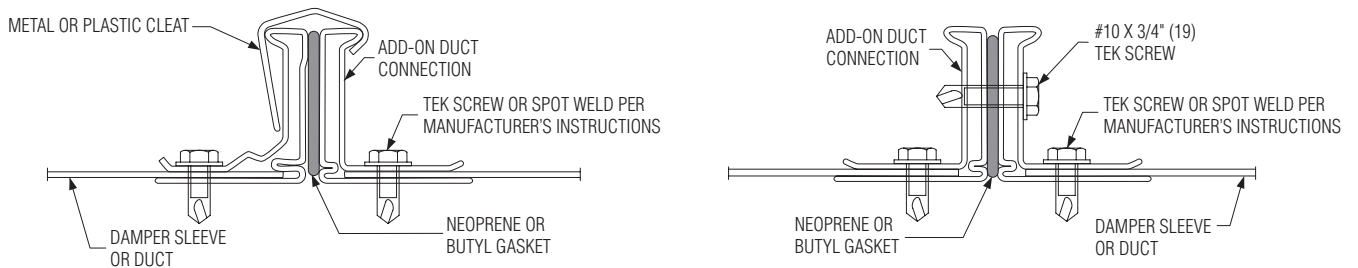


FIGURE 1. ADD-ON/ADD-ON

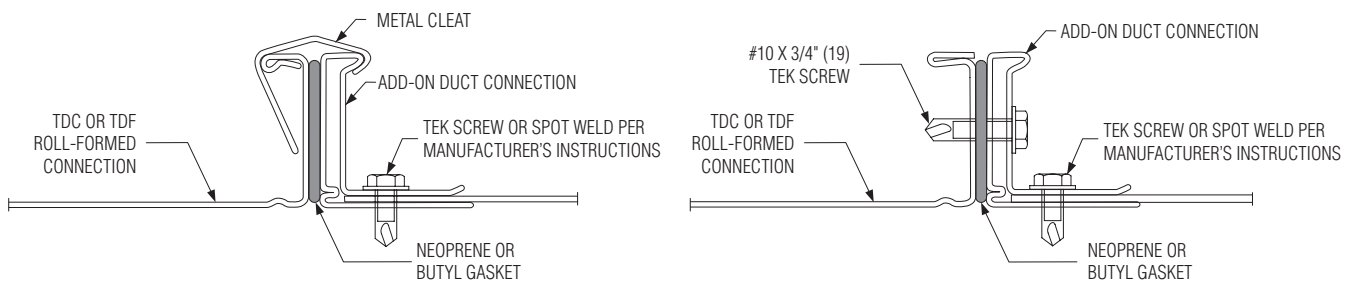


FIGURE 2. ROLL-FORMED/ADD-ON

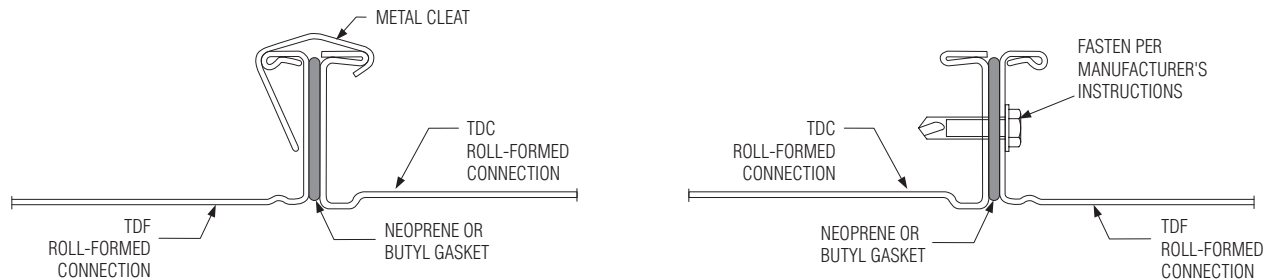


FIGURE 3. ROLL-FORMED/ROLL-FORMED

Dimensions are in inches (mm).



**Houston, Texas**  
Tel: 281-590-1172  
Fax: 281-590-3086

**Las Vegas, Nevada**  
Tel: 702-648-5400  
Fax: 702-638-0400

**Toronto, Canada**  
Tel: 416-744-3300  
Fax: 416-744-3360

**Calgary, Canada**  
Tel: 403-279-8619  
Fax: 403-279-5035

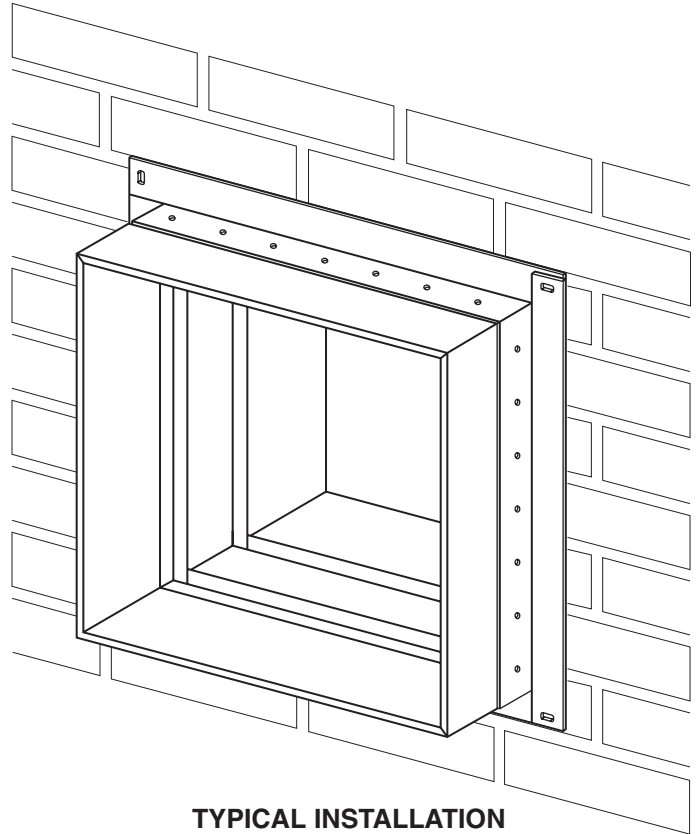
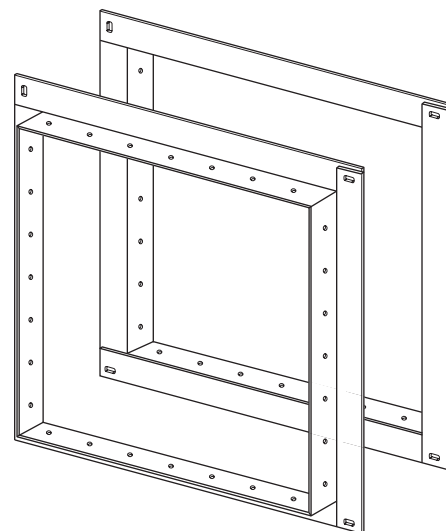
**"QUICK-SET" RETAINING ANGLES BOTH SIMPLIFY AND SPEED INSTALLATION,  
SAVING BOTH TIME AND MONEY.****BENEFITS:**

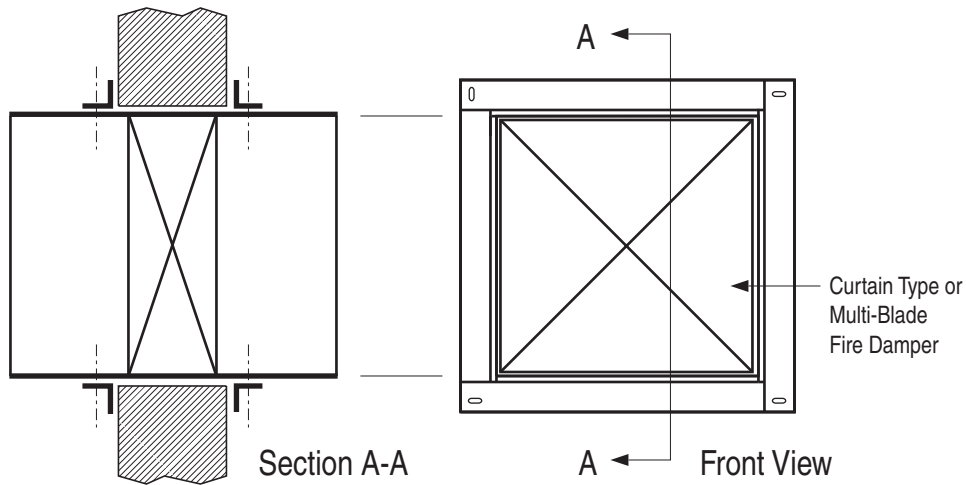
- One piece angles are fastened together in the corners. Only two sets of angles to handle per damper (rather than four separate angles per side).
- Angles are shipped with damper - no sorting or matching.
- Provided with pre-drilled fastening holes on 2" (51) centers to ensure correct angle/sleeve attachment.
- Factory fabricated by Nailor to suit the individual fire damper.
- Reduced cost when compared to conventional retaining angles.
- Dampers can ship directly to the job site complete with all necessary installation sheet metal hardware (saves on double handling at contractor's shop).
- Help ensure a correct installation as per U.L. approved installation instructions.

The majority of installing contractors view fire damper installation as a costly time consuming and troublesome procedure. Eight conventional angles must be custom fabricated for each damper either in a sheet metal shop or at the job site and sized to suit each individual damper. Invariably, they are mislaid or lost and must be matched to each factory supplied damper.

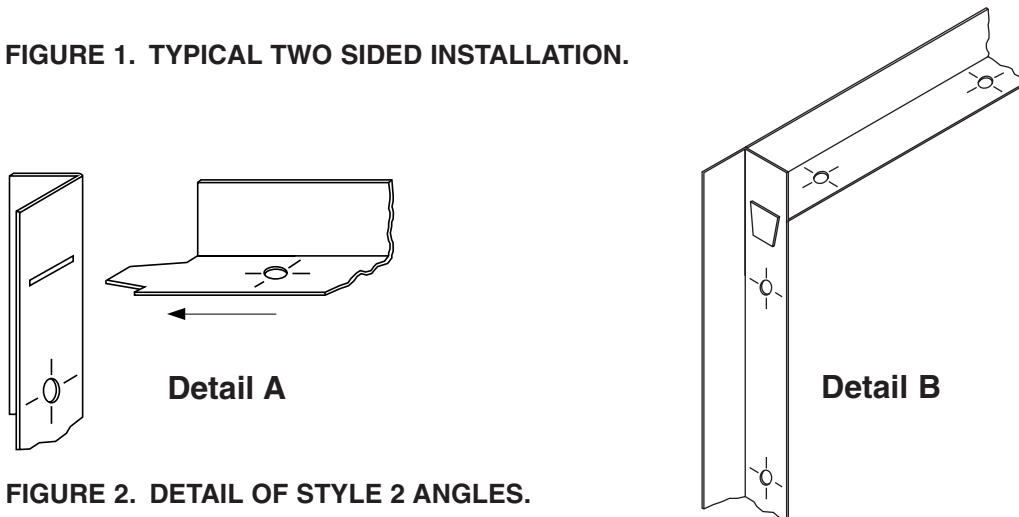
The Nailor "Quick-Set" solution solves the majority of problems. They are pre-formed to fit and ship with the individual damper for ultimate convenience. "Quick-Set" angles are supplied with correctly spaced pre-drilled screw-holes to ensure a quick, easy and accurate installation for all integral sleeve Nailor fire and combination fire/smoke dampers - no measuring required.

"Quick-Set" retaining angles provide the "complete" installation package. Simple, fast, convenient.

**TYPICAL INSTALLATION****TYPICAL PAIR OF PRE-ASSEMBLED  
'QUICK-SET' RETAINING ANGLES**



**FIGURE 1. TYPICAL TWO SIDED INSTALLATION.**



**FIGURE 2. DETAIL OF STYLE 2 ANGLES.**

**APPLICATION:**

The Nailor Quick-Set Retaining Angle System may be used in lieu of conventional retaining angles on all Nailor Fire and Combination Fire / Smoke Dampers.

Quick-Set angles are supplied in one of two styles, dependent upon fire resistance label, damper size and installation method.

**Style 1:** 1 1/2" x 1 1/2" x 20 ga. (38 x 38 x 1.0) Four sides are connected together with rivets in three corners.

Standard for the majority of applications with the following limitations:

- 1 1/2 hour label fire dampers
- Maximum Size: 36" x 36" (914 x 914)
- Two sided installation only

**Style 2:** 1 1/2" x 1 1/2" x 16 ga. (38 x 38 x 1.6) Slot and tab design. The retaining angle assembly for each side has four angles, each with a tab end and a slot end (Detail A). The tabs are to be inserted into the slots and knocked down either before or after fastening to the sleeve (Detail B).

- 1 1/2 or 3 hour label fire dampers
- Maximum Size: 90" x 48" (2286 x 1219) or 48" x 90" (1219 x 2286)
- Single side (1 1/2 hour only. Refer to Single Side Retaining Angles Supplementary Installation Instructions for size limitations) or two sided installation

**Refer to the Following Installation Instructions:**

Curtain Type Fire Dampers (D)0100 & (D)0500	FDINST
Curtain Type Fire Dampers 0200 & 0500 Thinline	FDTINST
Multi-Blade Fire Dampers 1200 & 1250	MBFDINST
Combination Fire/Smoke Dampers 1220	1220INST
Combination Fire/Smoke Dampers 1270	1270INST
Single Side Retaining Angles	FDSSRAINST



Dimensions are in inches (mm).

Page 2 of 2

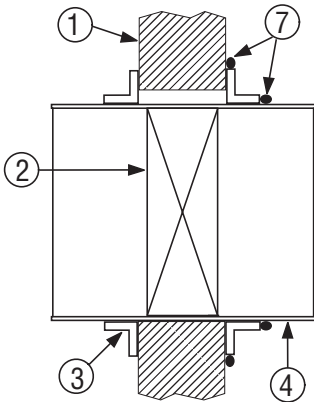


Houston, Texas  
Tel: 281-590-1172  
Fax: 281-590-3086

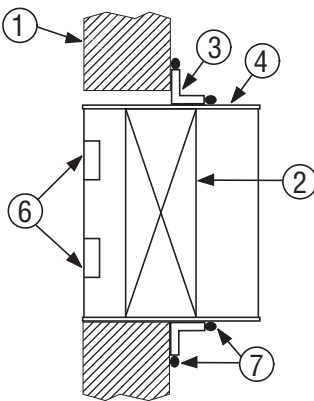
Las Vegas, Nevada  
Tel: 702-648-5400  
Fax: 702-638-0400

Toronto, Canada  
Tel: 416-744-3300  
Fax: 416-744-3360

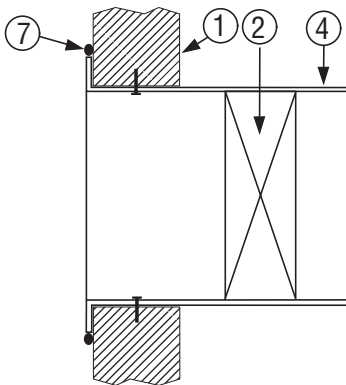
Calgary, Canada  
Tel: 403-279-8619  
Fax: 403-279-5035



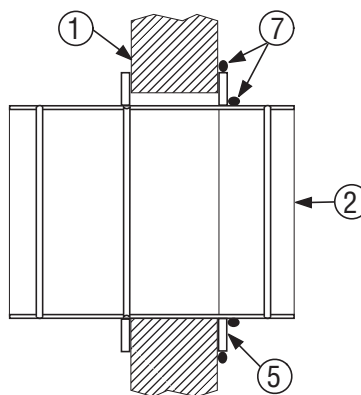
**Figure 1. Damper ducted both sides.**



**Figure 2. Damper sleeve with tabs for grille mounting**



**Figure 3. Out of Wall damper with flanged sleeve for grille mounting**



**Figure 4. Round damper**

**APPLICATION:**

Application of sealant between the retaining angles, retaining plates, or sleeve retaining flange and the fire rated wall or floor as applicable to the damper installation is not required by UL as a standard procedure. However, if an airtight seal is required by specification or local building code, sealant shall be applied as shown.

**METHOD**

Follow the sealant manufacturers' directions; remove dirt, grease, and moisture from the surfaces to be sealed. Apply a continuous bead of Dow Corning RTV732, Hilti Corporation FS-One, Nuco Inc. Self-Seal GG-200, Johns Manville Firetemp C1 or GE RTV108 sealant. Location of sealant should be as shown in Figures 1 through 4 and may be applied on one or both sides of the fire separation, as applicable to the model specific installation.

**IMPORTANT:**

**Do not apply sealant within the required expansion gap between the damper and the fire rated wall or floor.**

Press the surface of the sealant in place to dispel any air. Allow sealant to set and become tack-free before operating the damper.

Refer to the appropriate damper installation instructions for details on damper installation.

**ITEMS**

1. Fire Rated Wall or Floor
2. Damper
3. Retaining Angles
4. Sleeve
5. Retaining Plate
6. Mounting Tabs
7. Sealant (refer to text for specific sealant)

Dimensions are in inches (mm).



**Houston, Texas**  
Tel: 281-590-1172  
Fax: 281-590-3086

**Las Vegas, Nevada**  
Tel: 702-648-5400  
Fax: 702-638-0400

**Toronto, Canada**  
Tel: 416-744-3300  
Fax: 416-744-3360

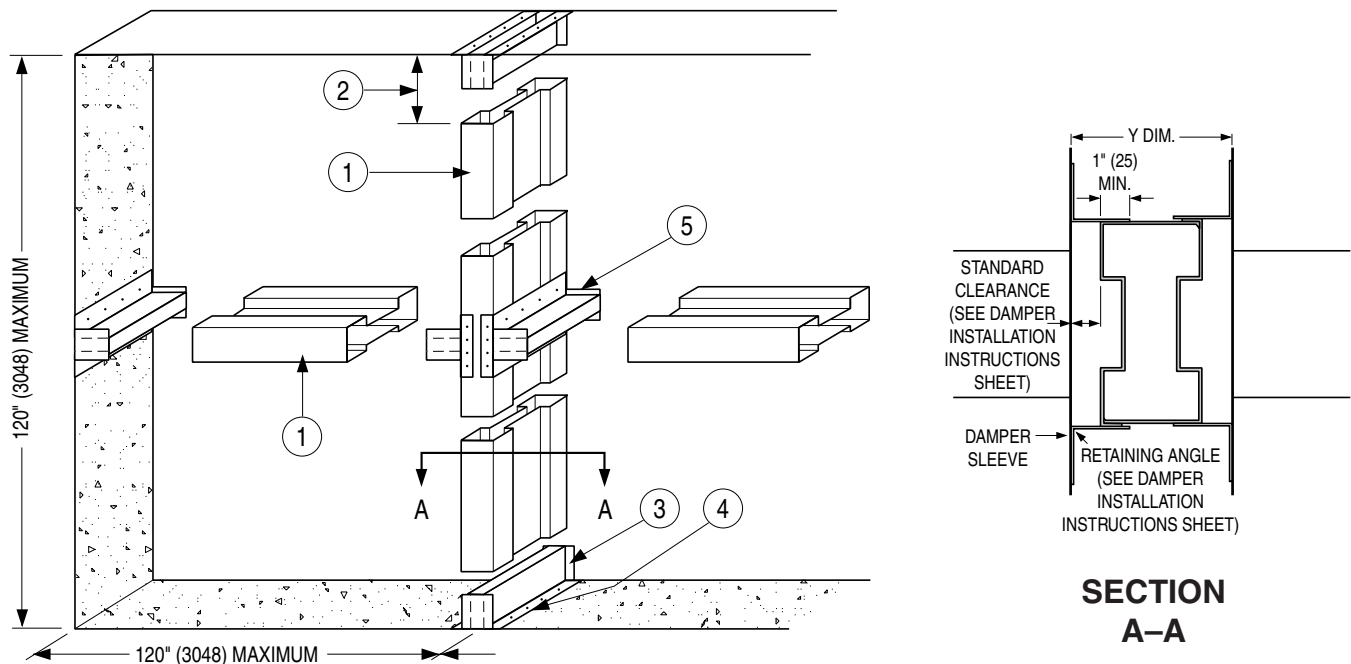
**Calgary, Canada**  
Tel: 403-279-8619  
Fax: 403-279-5035

## APPLICATION:

Fire dampers are UL/ULC Classified for their maximum size or maximum assembly size. Generic steel mullions can be used in static HVAC systems to separate vertically mounted 1 1/2 hour labeled galvanized steel fire dampers in vertical wall openings larger than maximum UL/ULC permitted multiple damper assembly size. Fire dampers must not exceed a maximum 120" (3048) height by unlimited width using vertical mullions every 120" (3048) max. Mullions are not intended to be part of the ductwork. (i.e. exposed to airflow).

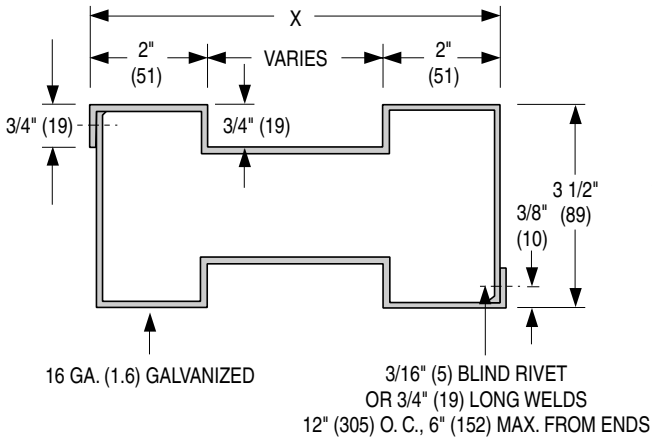
Whenever the duct size exceeds the maximum damper width or height, the opening must be divided into two or more separate openings with a mullion installed between the damper sections. The mullion consists of a vertical and/or horizontal mullion and mullion caps. One cap for each end of the mullion.

The steel mullion is intended for use only in concrete block or poured walls with 7" (178) minimum and 12" (305) maximum thickness. Hollow concrete block walls are to be suitably filled with minimum 3500 psi concrete for proper securing of mullions. **Important Note: Steel mullions are for use in static systems only. UL/ULC does not acknowledge their use with dynamic fire dampers.**

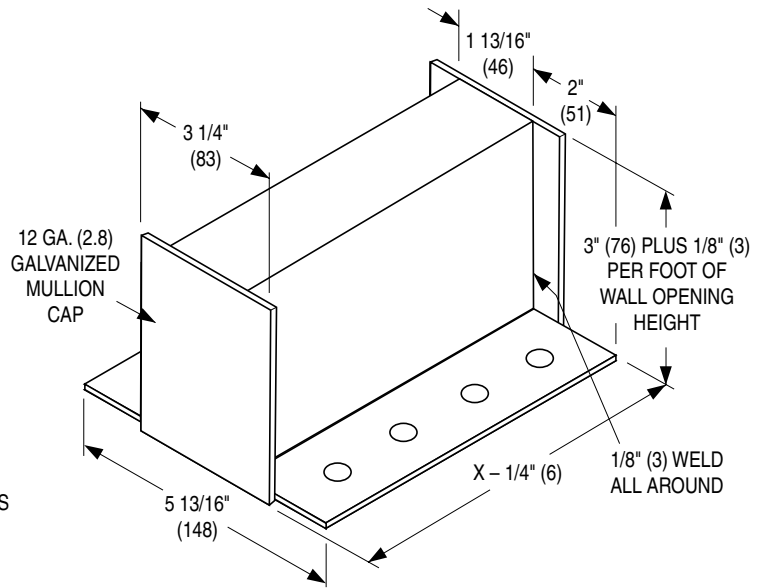


## FABRICATION AND GENERAL INSTALLATION:

1. Fabricate mullions of 16 ga. (1.6) galvanized steel as shown in **Figure 1**. Two mullion pieces are joined with 3/16" (5) diameter steel pop rivets or 3/4" (19) long welds located 6" (152) maximum from each end and 12" (305) O.C. maximum.
2. The mullion should permit clearance between the mullion and top cap. Required clearance is 1/8" (3) per foot of wall opening height. Minimum permitted clearance is 1/4" (6). Maximum permitted clearance is 1 1/4" (32) (e.g. for an 8 ft. (2438) high opening the permitted clearance is 1/8" (3) x 8 = 1" (25) +).
3. Fabricate two caps for each mullion of 12 ga. (2.8) galvanized steel as shown in **Figure 2** for vertical and horizontal mullions. (Caps must permit mullion to overlap each cap by minimum 3" (76)). Cap height is calculated by adding 3" (76) to permitted mullion expansion clearance which is 1/8" (3) per foot of wall opening height. Insert mullion caps into mullion ends allowing mullion to float between the caps. Do not fasten mullion to caps in any way. Locate within opening to provide correct expansion clearance for dampers.
4. Drill holes in caps and concrete for anchoring steel mullion caps with 1/4" (6) – 20 x 5/16" (8) steel screws and 3/8" (10) diameter x 1" (25) concrete expansion anchors. The eight holes to secure the cap (**Figure 3**) are equally spaced,  $X \div 8$  from both ends and 1/2" (13) inwards of each side.
5. Set horizontal mullion caps at vertical mullions as shown (**Figure 4**). If steel lintels are present, four 1" (25) welds (two per mullion cap leg) may be used to anchor each mullion cap.

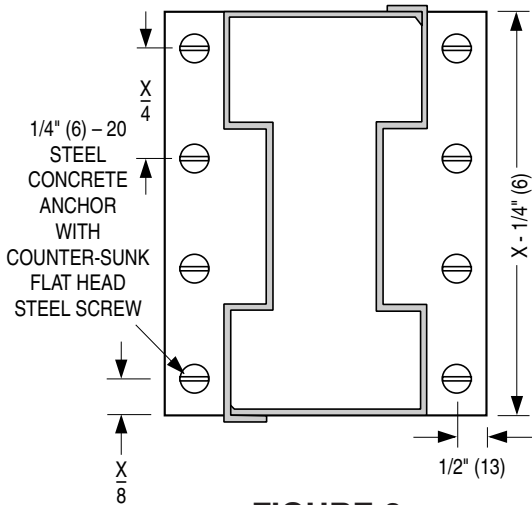


**FIGURE 1**  
MULLION CROSS-SECTION

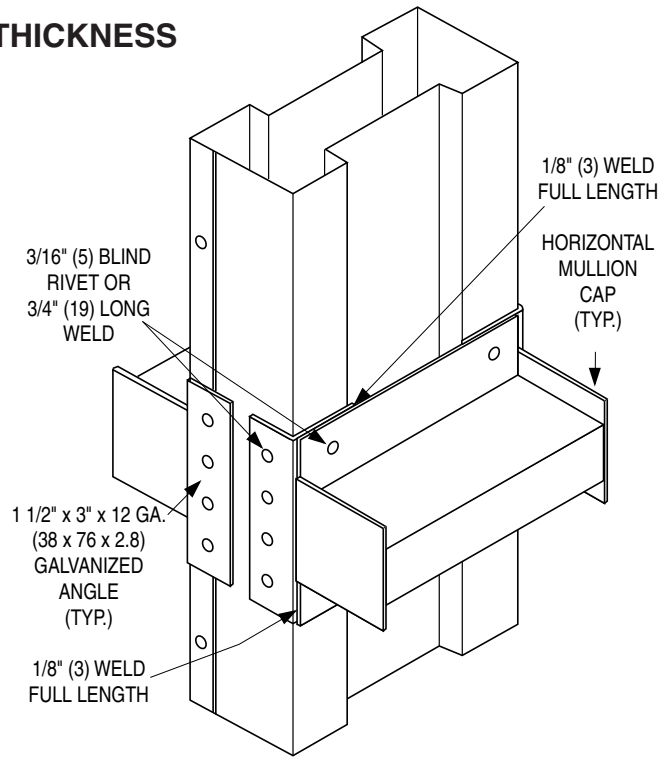


**FIGURE 2**

**X = WALL THICKNESS**



**FIGURE 3**



**FIGURE 4**



Refer to the UL or ULC Classification Marking on the Product

These instructions comply with Underwriters Laboratories Safety Standard 555.

Dimensions are in inches (mm).

Page 2 of 2



Houston, Texas  
Tel: 281-590-1172  
Fax: 281-590-3086

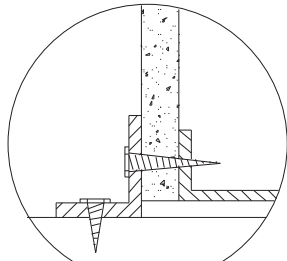
Las Vegas, Nevada  
Tel: 702-648-5400  
Fax: 702-638-0400

Toronto, Canada  
Tel: 416-744-3300  
Fax: 416-744-3360

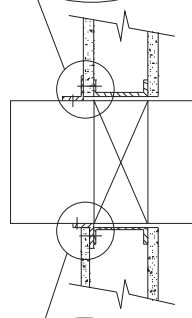
Calgary, Canada  
Tel: 403-279-8619  
Fax: 403-279-5035



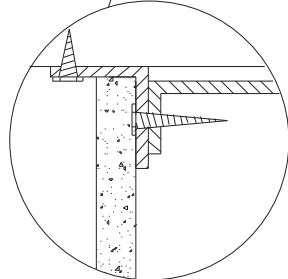
**Detail 1A**  
**Angle over**  
**drywall.**



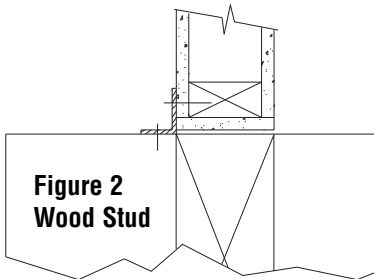
**Figure 1**  
**Metal Stud**



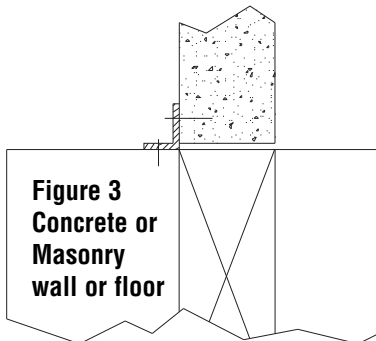
**Detail 1B**  
**Angle under**  
**drywall.**



**Figure 2**  
**Wood Stud**



**Figure 3**  
**Concrete or**  
**Masonry**  
**wall or floor**

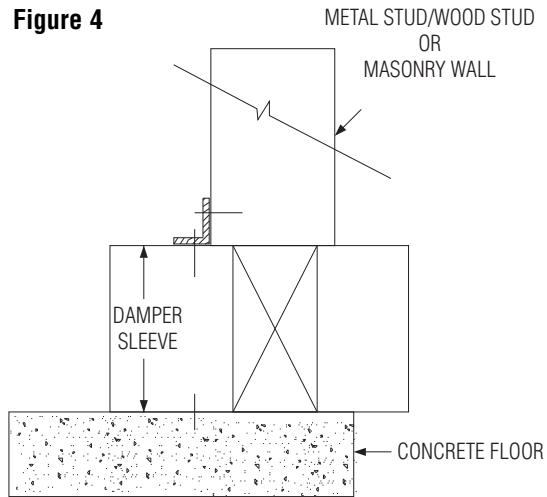


**NOTES:**

1. For the maximum sizes listed below, all Nailor 1 1/2 hour labeled curtain, multi-blade and combination fire/smoke dampers may be installed using single-side retaining angles in lieu of the conventional two-sided retaining angle method. Retaining angles may be field fabricated or factory supplied and may be installed in metal/wood stud or masonry walls and concrete floors.
2. Install dampers in accordance with the appropriate damper installation instruction sheet in conjunction with this supplement. Replace conventional two-sided retaining angles with single-sided retaining angles as appropriate. Retaining angles may be installed on either side for vertical partition installations, but must be installed on the top side for a floor installation. Retaining angles must be attached to both the sleeve and the wall or floor.
3. Retaining angles required on all four sides unless installed on top of a concrete floor slab (See Note 6).
4. Single-sided retaining angles shall be a minimum of 1 1/2" x 1 1/2" x 16 ga. (38 x 38 x 1.61) steel for metal stud, masonry walls or concrete floors. For wood stud partitions, retaining angles shall be a minimum of 2" x 1 1/2" x 16 ga. (51 x 38 x 1.61) steel. For metal stud partitions only, the single-side retaining angle may be directly attached to the metal stud prior to the installation of the drywall. See Detail 1B.
5. Attach the 1 1/2" (38) leg of the retaining angles to the damper sleeve using 1/2" (13) long welds, 1/4" (6) diameter bolts and nuts, 3/16" (5) diameter steel rivets or #8 sheet metal screws, 6" (152) o.c.. Secure the retaining angles to the structural members of a vertical drywall wall using drywall screws. In the case of wood stud construction (see Figure 2), the screws should be a minimum of 2 1/2" (64) long, with minimum 1 1/4" (32) penetration into framing. In the case of masonry walls or concrete floors (see Figure 3), use 1/4" (6) masonry anchors 1 1/2" (38) minimum length, with minimum 1 1/4" (32) penetration into wall or floor. All fasteners to be on a maximum of 12" (305) o.c. with a minimum of two fasteners per side, top, and bottom.
6. In the case where the damper sits directly on a concrete floor slab, the bottom retaining angle is not required if the damper sleeve is fastened directly to the slab using 1/4" (6) masonry anchors 1 1/2" (38) minimum length, with minimum 1 1/4" (32) penetration into the floor. All fasteners to be on a maximum of 12" (305) o.c. with a minimum of 2 fasteners (See Figure 4).



**Figure 4**



**7.** No firestop caulking is required on this product.

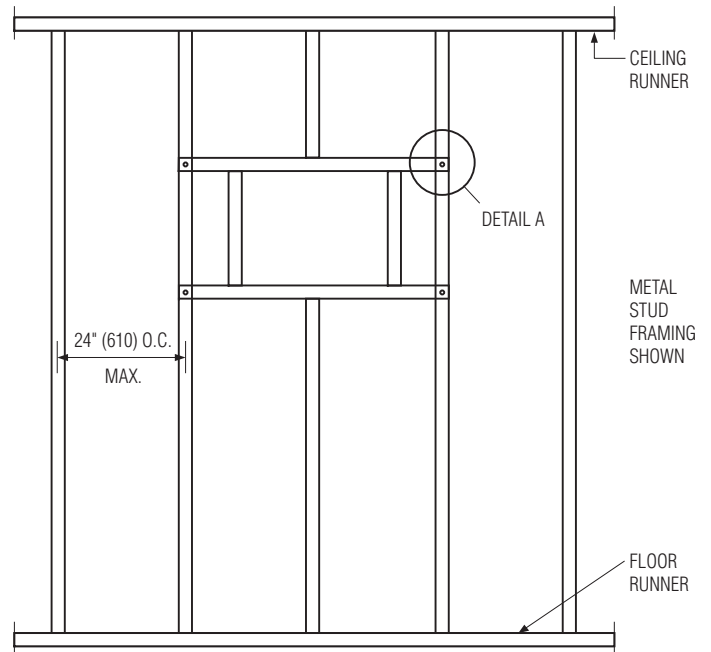
Underwriters' Laboratories file # R9492.

Also conforms to NFPA 90A and NFPA 92.

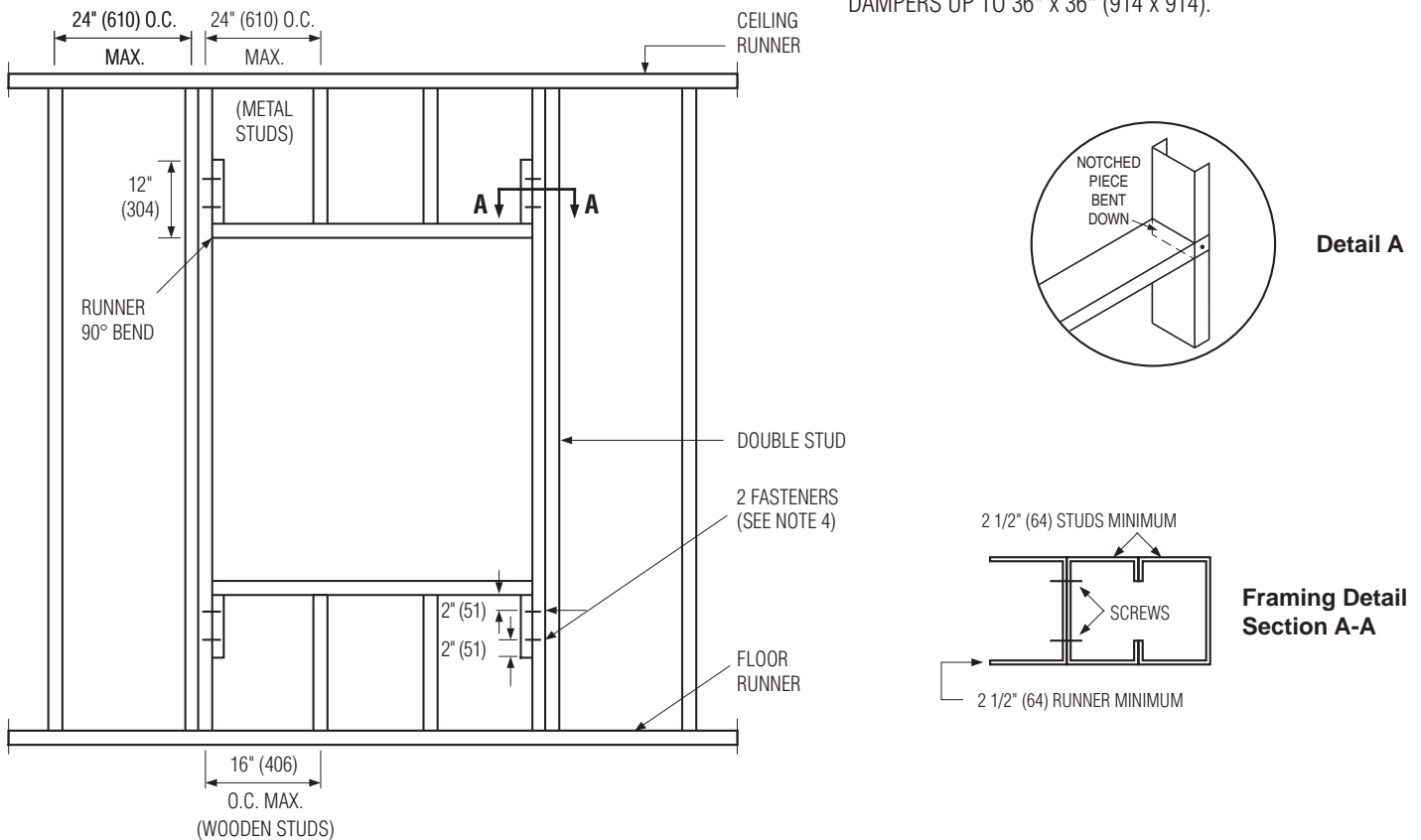
Maximum sizes: 96" W x 36" H (2438 x 914) or  
36" W x 96" H (914 x 2438).

**NOTES:**

1. These details are based upon tests conducted by the Gypsum Association. Consult the local authority having jurisdiction for other acceptable framing methods.
2. Frame wall openings as shown in Figure 1 or 2.
3. Gypsum panels must be screwed to all stud and runner flanges, 12" (305) max. o.c. surrounding opening.
4. All fasteners to be per UL/ULC Classified wall design.
5. UL/ULC wood stud designs require gypsum wallboard filler pieces to be installed around entire opening, screwed 12" (305) o.c. to web of runners and studs, covering all wood stud surfaces.  
 In UL metal stud designs, exposed steel surfaces need not be covered with gypsum wallboard. ULC metal stud construction however may still require filler pieces, check with the local authorities.
6. Refer to standard installation instructions sheet for additional details.



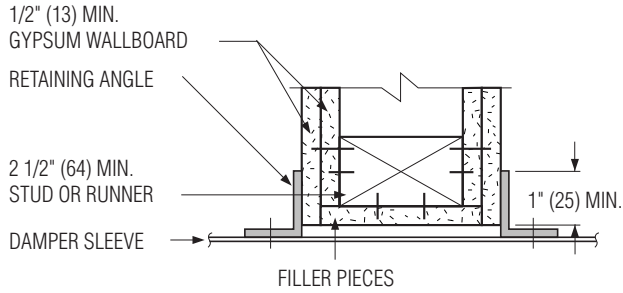
**FIGURE 1. SINGLE VERTICAL STUD OPENING PREPARATION DETAILS.**  
 DAMPERS UP TO 36" x 36" (914 x 914).



**FIGURE 2. DOUBLE VERTICAL STUD OPENING PREPARATION DETAILS.**  
 DAMPERS OVER 36" x 36" (914 x 914).

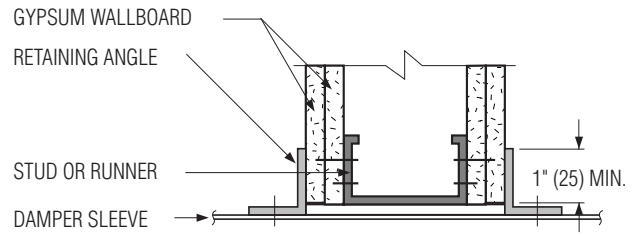
**TYPICAL STUD WALL DETAILS (See Notes on Page 1)**

**WOOD STUD DETAIL**

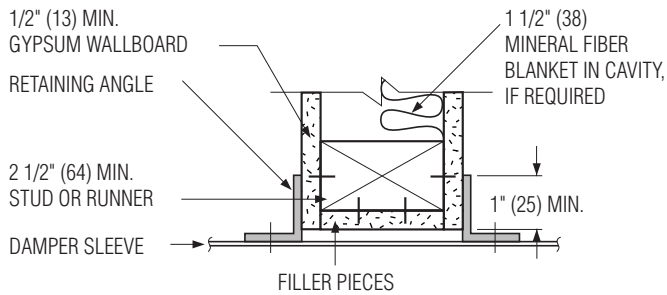


**2 Hour Partition Rating**

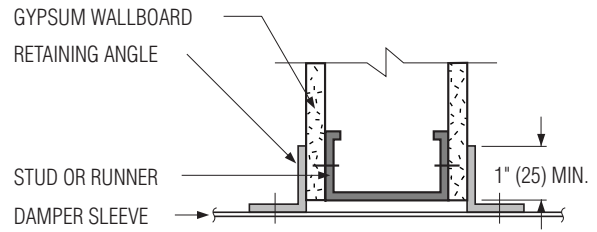
**METAL STUD DETAIL (UL DESIGN)**



**2 Hour Partition Rating**



**1 Hour Partition Rating**



**1 Hour Partition Rating**

Dimensions are in inches (mm).

Page 2 of 2

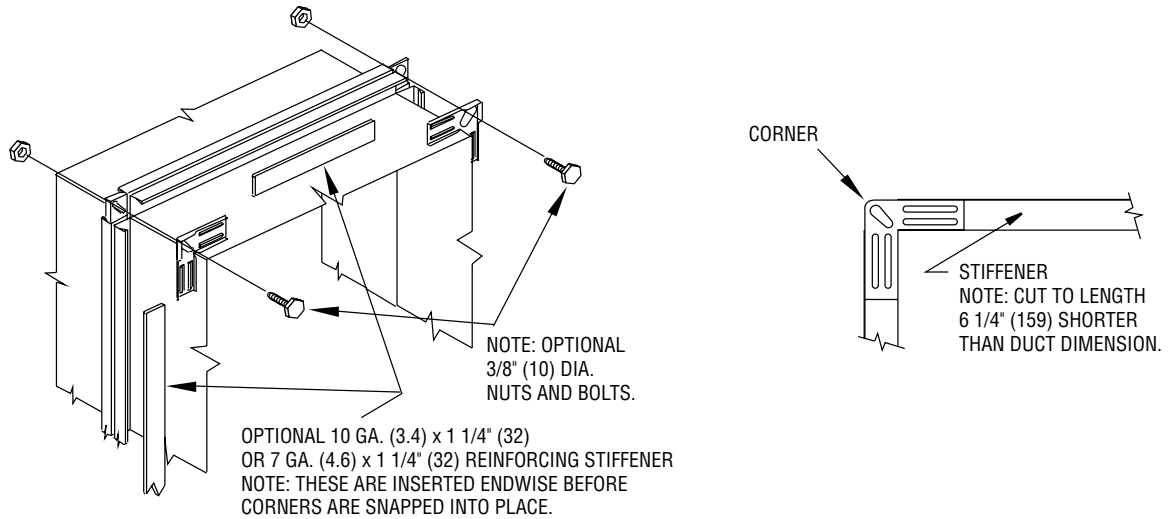


Houston, Texas  
Tel: 281-590-1172  
Fax: 281-590-3086

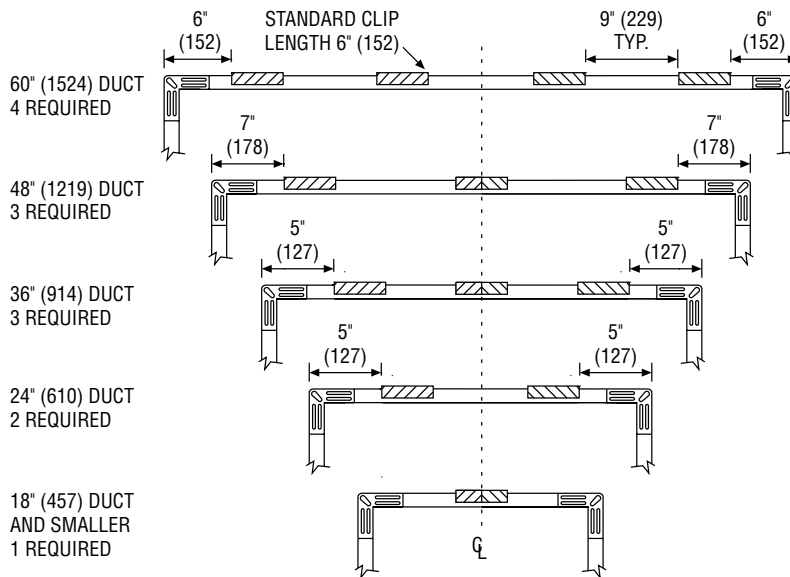
Las Vegas, Nevada  
Tel: 702-648-5400  
Fax: 702-638-0400

Toronto, Canada  
Tel: 416-744-3300  
Fax: 416-744-3360

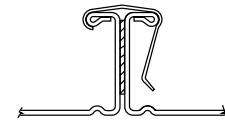
Calgary, Canada  
Tel: 403-279-8619  
Fax: 403-279-5035



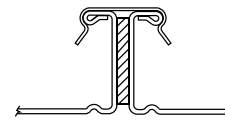
**RECOMMENDED CLIP SPACING**



**CLEAT DETAILS**



TDC CROSS SECTION



TDF CROSS SECTION

Damper Type	Max. Size W x H		No. Cleats Per Side
	(inches)	(mm)	
Curtain	18 x 18	457 x 457	1
	24 x 24	610 x 610	2
	48 x 48	1219 x 1219	3
	60 x 60	1524 x 1524	4
Multi-Blade	18 x 18	457 x 457	1
	24 x 24	610 x 610	2
	36 x 48	914 x 1219	3

**APPLICATION:**

TDC (by Lockformer) and TDF (by Engle) are approved as breakaway connections for joining the fire damper sleeve and the duct. The slip joints shown in standard installation instructions for curtain type fire dampers, multi-blade fire dampers and combination fire/smoke dampers may be replaced by one of these systems.

**INSTALLATION:**

TDC and TDF roll-formed 4-bolt flanged connections assembled per the manufacturers instructions using gaskets, metal cleats 6" (152) long with spacing as shown and four 3/8" (9.5) metal nuts and bolts. See also the TDC or TDF addendum to the SMACNA Duct Construction Standards.



**Houston, Texas**  
Tel: 281-590-1172  
Fax: 281-590-3086

**Ft. Lauderdale, Florida**  
Tel: 954-351-2444  
Fax: 954-351-2440

**Toronto, Canada**  
Tel: 416-744-3300  
Fax: 416-744-3360

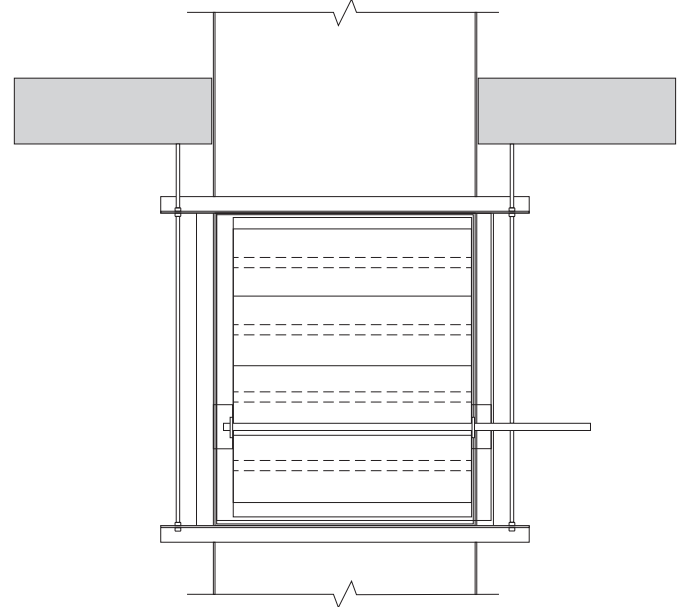
**Calgary, Canada**  
Tel: 403-279-8619  
Fax: 403-279-5035

These instructions are for installing vertical mount fire and combination fire smoke dampers in a fire resistant ventilation duct (UL Ventilation duct Assembly HNLN.V-5).



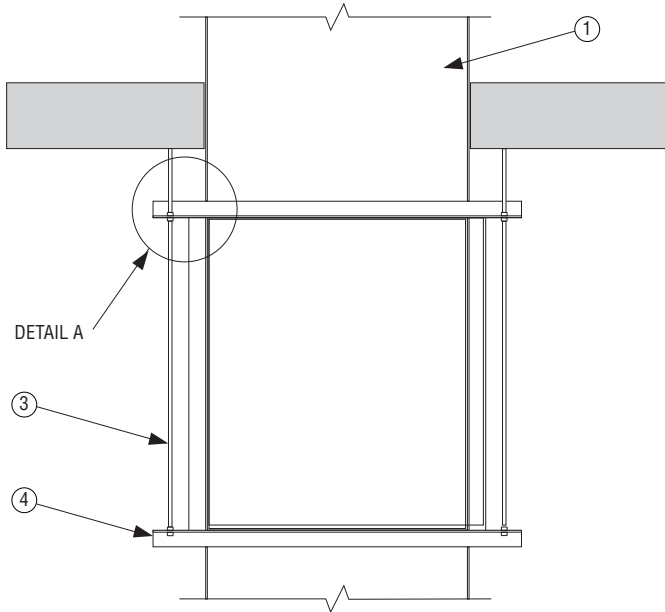
**NOTES:**

1. The damper sleeve must slip inside the fire resistant duct spool. Damper sleeve assembly will be 1/4" (6), 1/2" (13) maximum, smaller than duct spool size.
2. Damper is to be supplied with factory mounted sleeve. Sleeve gauge will be minimum of 16 ga. (1.5) for dampers up to 36" wide x 24" high (914 x 610) and 14 ga. (2) for dampers exceeding 36" wide x 24" high (914 x 610).
3. Mounting angles need to be the following sizes:
  - 1 1/2" x 1 1/2" x 1/4" up to 24" (38 x 38 x 6 up to 610)
  - 2" x 2" x 1/4" over 24" up to 32" (51 x 51 x 6 over 610 up to 813)
  - 2 1/2" x 2 1/2" x 1/4" over 32" up to 40" (64 x 64 x 6 over 813 up to 1016)
  - 3" x 3" x 1/4" above 40" (76 x 76 x 6 above 1016)
4. Mounting angle fasteners:
  - #10 bolts or screws
  - 3/16" (4.7) steel rivets
  - 1/2" (13) long welds
5. Mounting Angle Fasteners Spacing:
  - Mounting angles to dampers, space fasteners on 6" (152) on center.
  - Mounting angle to spool flange, space fasteners on 12" (305) on center.
  - Minimum 2 fasteners per side
6. Hanger rods:
  - 3/8" (10) threaded rod anchored to the floor above and attached to the mounting angles through hole in the angles and secured with hex nut and washer (items 5 & 6). Anchor to masonry per assembly No. V-5.
7. Duct to Damper Sleeve Connection:
  - See the fire damper or the combination fire smoke installation instructions for breakaway, flanged, or non-breakaway connections.

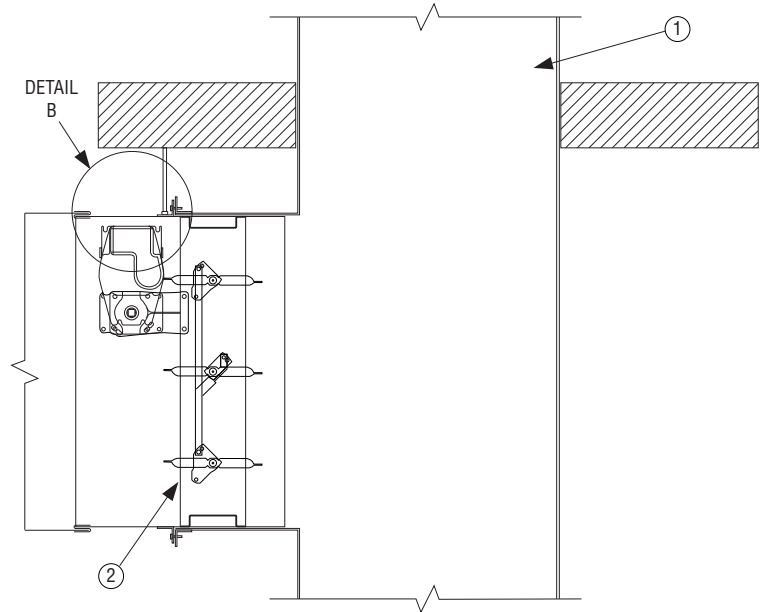


**END VIEW**

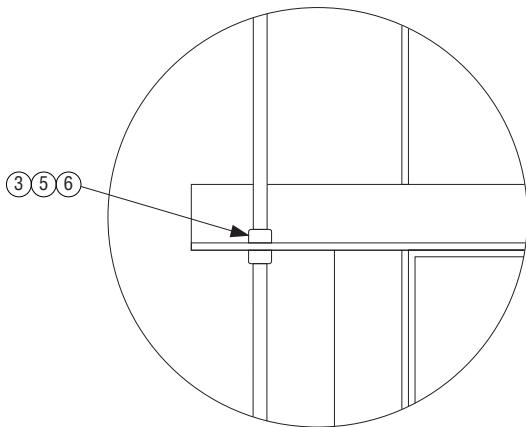
Item	Description
1	Fire Resistant Ventilation Duct (UL HNLN Assembly No. V-5)
2	Fire Damper or Combination Fire/Smoke Damper
3	Hanger rods in accordance with assembly No. V-5
4	Mounting angles (see instruction #3)
5	3/8" (10) hex nuts
6	3/8" (10) flat washer
7	Mounting angle fasteners (see instruction #4)



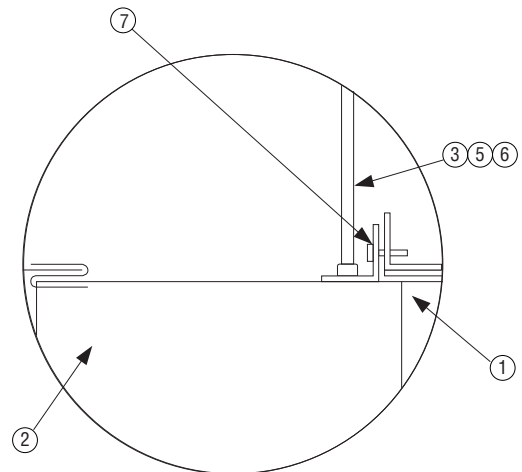
END VIEW



SIDE VIEW



DETAIL A



DETAIL B

Dimensions are in inches (mm).

Page 2 of 2



Houston, Texas  
Tel: 281-590-1172  
Fax: 281-590-3086

Las Vegas, Nevada  
Tel: 702-648-5400  
Fax: 702-638-0400

Toronto, Canada  
Tel: 416-744-3300  
Fax: 416-744-3360

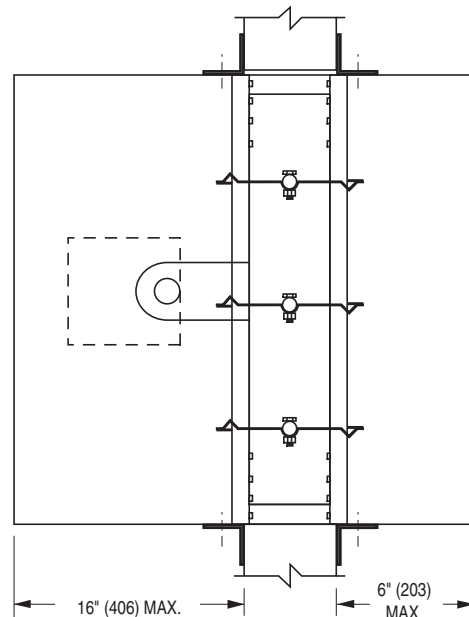
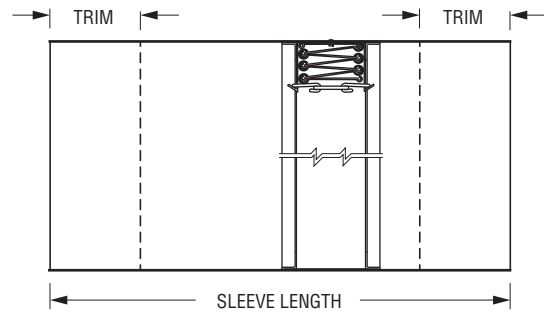
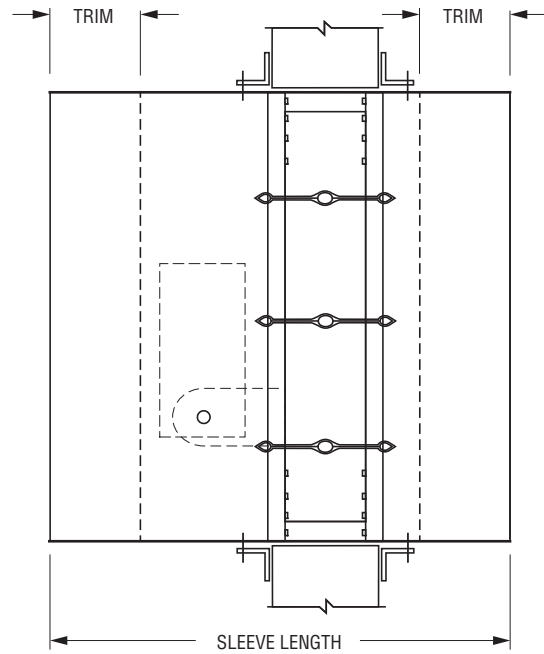
Calgary, Canada  
Tel: 403-279-8619  
Fax: 403-279-5035



Trimming of factory-supplied sleeves may be necessary to accommodate field conditions or applications. Other damper components such as actuators and fuse links should not be altered.

**NOTES:**

- 1. Sleeve Length on Non-actuator side:** 6" (152) maximum sleeve length beyond fire-rated barrier on non-actuator side.
- 2. Sleeve Length on Actuator side:** 16" (406) maximum sleeve length beyond fire-rated barrier on actuator side.



Dimensions are in inches (mm).



**Houston, Texas**  
Tel: 281-590-1172  
Fax: 281-590-3086

**Las Vegas, Nevada**  
Tel: 702-648-5400  
Fax: 702-638-0400

**Toronto, Canada**  
Tel: 416-744-3300  
Fax: 416-744-3360

**Calgary, Canada**  
Tel: 403-279-8619  
Fax: 403-279-5035