



**MODULATING COMBINATION FIRE/SMOKE DAMPER**  
**AIRFOIL BLADE • HIGH PERFORMANCE**  
**1 1/2 HR. LABEL • ULTRA-LOW LEAKAGE**  
**MODELS: 1220M AND 1221M (TYPE A)**



**QUALIFICATIONS:**

- **UL 555 & CAN/ULC-S112 CLASSIFIED DYNAMIC FIRE DAMPER** 1 1/2 hr. Label (File #'s R9492 & R19569).
- **UL 555S CLASSIFIED SMOKE DAMPER** (File # R9492) Leakage Class I at 250°F elevated temperature.
- **City of New York. MEA #366-03-M.**
- **California State Fire Marshal: Fire Damper Listing No. 3225-0935:0106.**
- **Meets NFPA 80, 90A, 92, 101 and 105 as well as IBC and NBC (Canada) Building Code requirements.**
- **Maximum velocity: 2000 fpm @ 4" w.g. (10 m/s @ 1 kPa).**

The 1220M Series modulating dampers are classified for use as a volume control damper in applications where building codes require both a fire damper for the protection of ductwork penetrations in walls or floors that have a fire resistance rating of up to 2 hours and a leakage rated damper for operational smoke control in static or dynamic smoke management systems.

The 1220M Series has been especially designed and tested to provide premium performance. It offers the lowest leakage class available and is qualified for installation with airflow in either direction and inverted mounting. Airfoil blade design and elimination of blade sills, top and bottom, provide a low pressure drop design. Unique, inter-locking double skin blade design provides flame and smoke seal under fire conditions.

**STANDARD CONSTRUCTION:**

- Frame:** 5" x 7/8" x 16 ga. (127 x 22 x 1.6) galv. steel hat channel.
- Blades:** 14 ga. (2.0) equivalent galvanized steel formed airfoil on 5 1/2" (140) centers. Opposed action.
- Linkage:** Concealed in frame. 12 ga. (2.7) plated steel.
- Bearings:** 1/2" (13) dia. self-lubricating oilite bronze.
- Axles:** 1/2" (13) dia. plated steel double bolted to blades.
- Jackshaft:** 1/2" (13) dia. cadmium plated steel.
- Jamb Seals:** Stainless steel.

**Heat Responsive Device (Controlled Closure):**

ERL (Electric Resettable Link) is standard on dampers with electric actuators: 250°F (121°C) standard. 165°F (74°C) and 212°F (100°C) available.

PRL (Pneumatic Replaceable Link) is standard on dampers with pneumatic actuators: 212°F (100°C) standard. 165°F (74°C) available.

**Sizes (Duct W x H):**

Velocity/ Pressure Rating	Elevated Temp. °F	Minimum				
		Single Section		Maximum		
		Vertical/Horizontal	Vertical	Horizontal	Vertical	Horizontal
24	250	8" x 8" (203 x 203). 6" x 6" (152 x 152) with low profile frame (maximum size is 18" x 6" [457 x 152]).	36" x 48" (914 x 1219)	32" x 48" (813 x 1219)	144" x 96" (3658 x 2438)	128" x 96" (3251 x 2438)

**Note:** Dampers with duct heights less than 6" (152) (8" [203] if width is over 18 [457]) require a Type 'B' sleeve enclosure (Model 1222M). Duct sizes less than 8" (203) in width require a Type 'C' enclosure (Model 1223M).

**BASE MODEL SELECTION:**

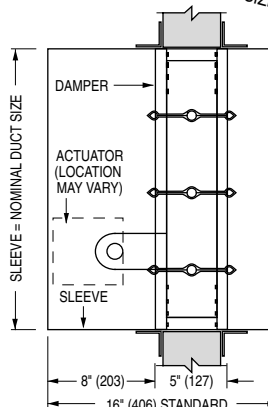
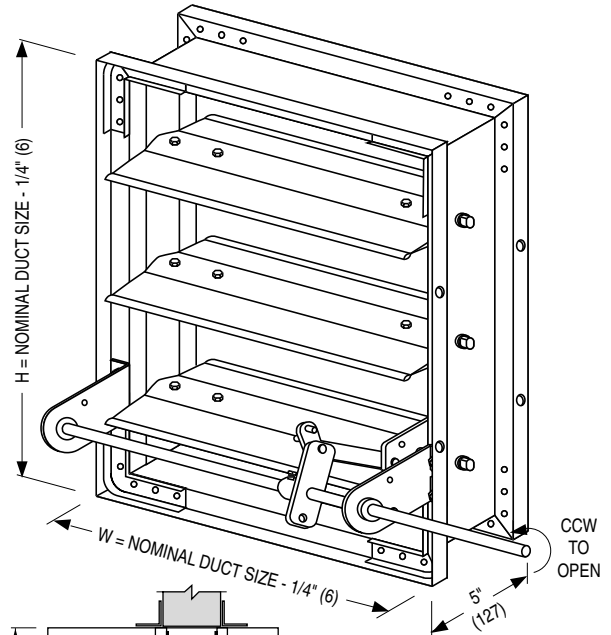
- 1220M** With side actuator mounting plate
- 1221M** Standard factory sleeve (caulked to UL requirements) 16" long x 20 ga. (406 x 1.0).
- 1221M** Non-standard sleeve. Specify \_\_\_\_\_ length \_\_\_\_\_ ga. Available up to 36" (914) dependent upon wall thickness and 10 through 20 ga. (3.5 through 1.0).

**SCHEDULE TYPE:**

**PROJECT:**

**ENGINEER:**

**CONTRACTOR:**



Wall Thickness	Minimum Sleeve Length
4 (102)	16 (406)
8 (203)	20 (508)
12 (305)	24 (610)
16 (406)	28 (711)

**LEAKAGE CLASS/ELEVATED TEMPERATURE:**  
**I @ 250°F**

**DYNAMIC VELOCITY/PRESSURE RATING:**  
**24 2000 fpm @ 4" w.g.**

**ACTUATOR SELECTION:**

- Electric**  **Pneumatic**

**ACTUATOR LOCATION:**

- External (std.)**  **Internal (in the airstream)**

**ACTUATOR FAIL POSITION: Closed.**

**OPTIONS:**

- BS** Stainless steel bearings
- MLS-300** Position indicator switch pack
- MLS-400** Electric Fire Sensor (Re-openable control system). Includes dual heat sensors (165°F and 250°F) and position indicator switch pack.
- QS1** Quick-set retaining angle (one side)
- QS2** Quick-set retaining angles (two sides)
- TDF1** Flange (one end) } (20 or 22 ga.)
- TDF2** Flange (both ends) } sleeves only

For installation instructions, see IOM-1220INST.  
 Dimensions are in inches (mm).

DATE	B SERIES	SUPERSEDES	DRAWING NO.
6 - 14 - 13	1200	5 - 7 - 12	1220M-1



**MODULATING COMBINATION FIRE/SMOKE DAMPER**  
**AIRFOIL BLADE • HIGH PERFORMANCE**  
**1 1/2 HR. LABEL • ULTRA-LOW LEAKAGE**  
**MODEL: 1222M (TYPE B SLEEVE ENCLOSURE)**



FOR DUCTS 8" (203) OR MORE IN WIDTH AND UNDER 8" (203) IN HEIGHT (6" [152] IF WIDTH IS 18" [457] OR UNDER).

**QUALIFICATIONS:**

- **UL 555 & CAN/ULC-S112 CLASSIFIED DYNAMIC FIRE DAMPER** 1 1/2 hr. Label (File #'s R9492 & R19569).
- **UL 555S CLASSIFIED SMOKE DAMPER** (File # R9492) Leakage Class I at 250°F elevated temperature.
- **City of New York. MEA #366-03-M.**
- **California State Fire Marshal: Fire Damper Listing No. 3225-0935:106.**
- **Meets NFPA 80, 90A, 92A, 92B, 101 and 105 as well as IBC and NBC (Canada) Building Code requirements.**
- **Maximum velocity: 2000 fpm @ 4" w.g.**

The 1220M Series modulating dampers are classified for use as a volume control damper in applications where building codes require both a fire damper for the protection of ductwork penetrations in walls or floors that have a fire resistance rating of up to 2 hours and a leakage rated damper for operational smoke control in static or dynamic smoke management systems.

The 1220M Series has been especially designed and tested to provide premium performance. It offers the lowest leakage class available and is qualified for installation with airflow in either direction and inverted mounting. Airfoil blade design and elimination of blade sills, top and bottom, provide a low pressure drop design.

Unique, inter-locking double skin blade design provides flame and smoke seal under fire conditions.

**STANDARD SPECIFICATION:**

**Frame:** 5" x 7/8" x 16 ga. (127 x 22 x 1.6) galvanized steel hat channel.

**Blades:** 14 ga. (2.0) equivalent galvanized steel formed airfoil on 5 1/2" (140) centers.

**Linkage:** Concealed in frame. 12 ga. (2.7) plated steel.

**Bearings:** 1/2" (13) dia. self-lubricating oilite bronze.

**Axles:** 1/2" (13) dia. plated steel double bolted to blades.

**Jackshaft:** 1/2" (13) dia. cadmium plated steel.

**Jamb Seals:** Stainless steel.

**Heat Responsive Device (Controlled Closure):**

ERL (Electric Resettable Link) is standard on dampers with electric actuators: 250°F (121°C) standard. 165°F (74°C) and 212°F (100°C) available.

PRL (Pneumatic Replaceable Link) is standard on dampers with pneumatic actuators: 212°F (100°C) standard. 165°F (74°C) available.

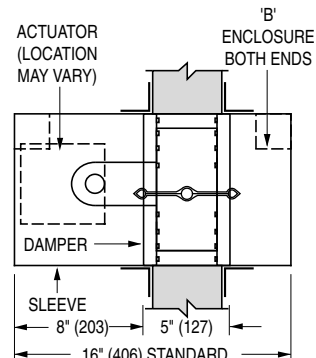
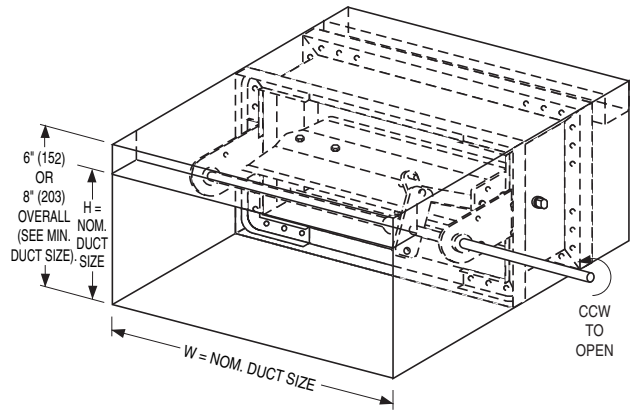
**Sizes (Duct W x H):**

Velocity/ Pressure Rating	Elevated Temp. °F	Minimum		Maximum		
		Single Section		Single Section		Multiple Section
		Vertical/Horizontal	Vertical	Horizontal	Vertical	Horizontal
24	250	8" x 4" (203 x 102) (overall damper height is 8" [203]; 6" [152] on duct sizes 18" x 5 1/2" [457 x 140] and under).	36" x 7 1/2" (914 x 191)	32" x 7 1/2" (813 x 191)	144" x 7 1/2" (3658 x 191)	128" x 7 1/2" (3251 x 191)

**Note:** Duct sizes less than 8" (203) in width require a Type 'C' enclosure (Model 1223M).

**SLEEVE/ENCLOSURE SELECTION:**

- 1222M** Standard factory sleeve (caulked to UL requirements) 16" long x 20 ga. (406 x 1.0).
- 1222M** Non-standard sleeve. Specify \_\_\_\_\_ length \_\_\_\_\_ ga. Available up to 36" (914) dependent upon wall thickness and 10 through 20 ga. (3.5 through 1.0).



Wall Thickness	Minimum Sleeve Length
4 (102)	16 (406)
8 (203)	20 (508)
12 (305)	24 (610)
16 (406)	28 (711)

**LEAKAGE CLASS/ELEVATED TEMPERATURE:**  
I @ 250°F

**DYNAMIC VELOCITY/PRESSURE RATING:**  
24 2000 fpm @ 4" w.g.

**ACTUATOR SELECTION:**

- Electric  Pneumatic

**ACTUATOR LOCATION:** External.

**ACTUATOR FAIL POSITION:** Closed.

**OPTIONS:**

- BS** Stainless steel bearings
- MLS-300** Position indicator switch pack
- MLS-400** Electric Fire Sensor (Re-openable control system). Includes dual heat sensors (165°F and 250°F) and position indicator switch pack.
- QS1** Quick-set retaining angle (one side)
- QS2** Quick-set retaining angles (two sides)

For installation instructions, see IOM-1220INST.

**SCHEDULE TYPE:**

**PROJECT:**

**ENGINEER:**

**CONTRACTOR:**

Dimensions are in inches (mm).

DATE	B SERIES	SUPERSEDES	DRAWING NO.
5 - 7 - 12	1200	8 - 21 - 08	1220M-2



**MODULATING COMBINATION FIRE/SMOKE DAMPER**  
**AIRFOIL BLADE • HIGH PERFORMANCE**  
**1 1/2 HR. LABEL • ROUND DUCT CONNECTION**  
**MODEL: 1223M (TYPE C SLEEVE ENCLOSURE)**



**QUALIFICATIONS:**

- **UL 555 & CAN/ULC-S112 CLASSIFIED DYNAMIC FIRE DAMPER** 1 1/2 hr. Label (File #'s R9492 & R19569).
- **UL 555S CLASSIFIED SMOKE DAMPER** (File # R9492) Leakage Class I at 250°F elevated temperature.
- **City of New York. MEA #366-03-M.**
- **California State Fire Marshal: Fire Damper Listing No. 3225-0935:106.**
- **Meets NFPA 80, 90A, 92A, 92B, 101 and 105 as well as IBC and NBC (Canada) Building Code requirements.**
- **Maximum velocity: 2000 fpm @ 4" w.g.**

The 1220M Series modulating dampers are classified for use as a volume control damper in applications where building codes require both a fire damper for the protection of ductwork penetrations in walls or floors that have a fire resistance rating of up to 2 hours and a leakage rated damper for operational smoke control in static or dynamic smoke management systems.

The 1220M Series has been especially designed and tested to provide premium performance. It offers the lowest leakage class available and is qualified for installation with airflow in either direction and inverted mounting. Airfoil blade design and elimination of blade sills, top and bottom, provide a low pressure drop design.

Unique, inter-locking double skin blade design provides flame and smoke seal under fire conditions.

**STANDARD SPECIFICATION:**

- Frame:** 5" x 7/8" x 16 ga. (127 x 22 x 1.6) galvanized steel hat channel.
- Blades:** 14 ga. (2.0) equivalent galvanized steel formed airfoil on 5 1/2" (140) centers. Opposed action.
- Linkage:** Concealed in frame. 12 ga. (2.7) plated steel.
- Bearings:** 1/2" (13) dia. self-lubricating oilite bronze.
- Axles:** 1/2" (13) dia. plated steel double bolted to blades.
- Jackshaft:** 1/2" (13) dia. cadmium plated steel.
- Jamb Seals:** Stainless steel.

**Heat Responsive Device (Controlled Closure):**

ERL (Electric Resettable Link) is standard on dampers with electric actuators: 250°F (121°C) standard. 165°F (74°C) and 212°F (100°C) available.

PRL (Pneumatic Replaceable Link) is standard on dampers with pneumatic actuators: 212°F (100°C) standard. 165°F (74°C) available.

**Sizes (Duct Diameter):**

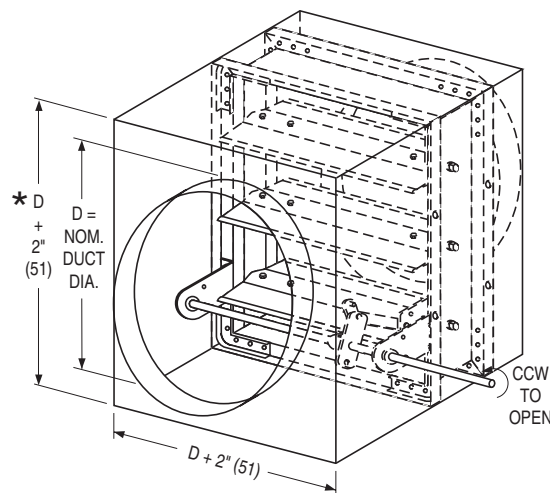
Velocity/ Pressure Rating	Elevated Temp. °F	Minimum		Maximum	
		Single Section		Single Section	Multiple Section
		Vertical/Horizontal	Vertical	Horiz.	Vertical/Horizontal
24	250	4" (102) dia.	34" (864) dia.	30" (762) dia.	94" (2388) dia.

**SLEEVE/ENCLOSURE SELECTION:**

- 1223M** Standard factory sleeve (caulked to UL requirements) 16" long x 20 ga. (406 x 1.0).
- 1223M** Non-standard sleeve. Specify \_\_\_\_\_ length \_\_\_\_\_ ga. Available up to 36" (914) dependent upon wall thickness and 10 through 20 ga. (3.5 through 1.0).

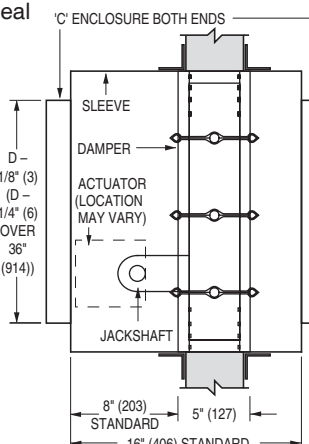
**LEAKAGE CLASS/ELEVATED TEMPERATURE: I @ 250°F**

**DYNAMIC VELOCITY/PRESSURE RATING: 24 2000 fpm @ 4" w.g.**



**\* Exception:**

5" (127) duct dia. is 8" (203) overall height.



Wall Thickness	Minimum Sleeve Length
4 (102)	16 (406)
8 (203)	20 (508)
12 (305)	24 (610)
16 (406)	28 (711)

**ACTUATOR SELECTION:**

- Electric**  **Pneumatic**

**ACTUATOR LOCATION:**

- External** (std.)  **Internal** (in the airstream)

**ACTUATOR FAIL POSITION: Closed.**

**OPTIONS:**

- BS** Stainless steel bearings
- MLS-300** Position indicator switch pack
- MLS-400** Electric Fire Sensor (Re-openable control system). Includes dual heat sensors (165°F and 250°F) and position indicator switch pack.
- QS1** Quick-set retaining angle (one side)
- QS2** Quick-set retaining angles (two sides)

For installation instructions, see IOM-1220INST.  
 Dimensions are in inches (mm).

<b>SCHEDULE TYPE:</b>				
<b>PROJECT:</b>				
<b>ENGINEER:</b>	<b>DATE</b>	<b>B SERIES</b>	<b>SUPERSEDES</b>	<b>DRAWING NO.</b>
<b>CONTRACTOR:</b>	9 - 1 - 23	1200	5 - 7 - 12	1220M-3



**MODULATING COMBINATION FIRE/SMOKE DAMPER**  
**AIRFOIL BLADE • HIGH PERFORMANCE**  
**3 HR. LABEL • ULTRA-LOW LEAKAGE**  
**MODELS: 1220M-3 AND 1221M-3 (TYPE A)**



**QUALIFICATIONS:**

- UL 555 & CAN/ULC-S112 CLASSIFIED DYNAMIC FIRE DAMPER 3 hr. Label (File #'s R9492 & R19569).
- UL 555S CLASSIFIED SMOKE DAMPER (File # R9492) Leakage Class I at 250°F elevated temperature.
- City of New York. MEA #366-03-M.
- California State Fire Marshal: Fire Damper Listing No. 3225-0935:106.
- Meets NFPA 80, 90A, 92A, 92B, 101 and 105 as well as IBC and NBC (Canada) Building Code requirements.
- Maximum velocity: 2000 fpm @ 4" w.g.

The 1220M-3 Series modulating dampers are classified for use as a volume control damper in applications where building codes require both a fire damper for the protection of ductwork penetrations in walls or floors that have a fire resistance rating of up to 4 hours and a leakage rated damper for operational smoke control in static or dynamic smoke management systems.

The 1220M-3 Series has been especially designed and tested to provide premium performance. It offers the lowest leakage class available and is qualified for installation with airflow in either direction and inverted mounting. Airfoil blade design and elimination of blade sills, top and bottom, provide a low pressure drop design.

Unique, inter-locking double skin blade design provides flame and smoke seal under fire conditions.

**STANDARD SPECIFICATION:**

- Frame:** 5" x 7/8" x 16 ga. (127 x 22 x 1.6) galvanized steel hat channel.  
**Blades:** 14 ga. (2.0) equivalent galvanized steel formed airfoil on 5 1/2" (140) centers. Opposed action.  
**Linkage:** Concealed in frame. 12 ga. (2.7) plated steel.  
**Bearings:** 1/2" (13) dia. self-lubricating oilite bronze.  
**Axles:** 1/2" (13) dia. plated steel double bolted to blades.  
**Jackshaft:** 1/2" (13) dia. cadmium plated steel.  
**Jamb Seals:** Stainless steel.

**Heat Responsive Device (Controlled Closure):**

ERL (Electric Resettable Link) is standard on dampers with electric actuators: 250°F (121°C) standard. 165°F (74°C) and 212°F (100°C) available.

PRL (Pneumatic Replaceable Link) is standard on dampers with pneumatic actuators: 212°F (100°C) standard. 165°F (74°C) available.

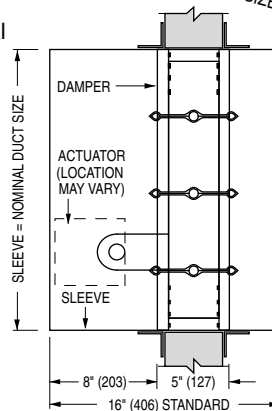
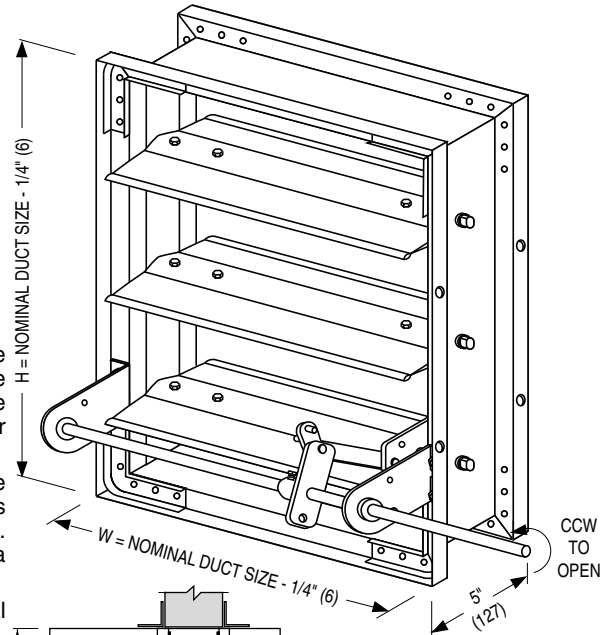
**Sizes (Damper W x H):**

Velocity/ Pressure Rating	Elevated Temp. °F	Minimum		Maximum		
		Single Section		Single Section		Multiple Section
		Vertical/Horizontal	Vertical	Vertical	Horizontal	
24	250	8" x 8" (203 x 203)	36" x 48" (914 x 1219)	32" x 48" (813 x 1219)	120" x 96" (3048 x 2438) (maximum each section is 30" x 48" [762 x 1219])	

**Note:** Dampers with duct heights less than 8" (203) require a Type 'B' sleeve enclosure (Model 1222M-3). Duct sizes less than 8" (203) in width require a Type 'C' enclosure (Model 1223M-3).

**BASE MODEL SELECTION:**

- 1220M-3** With side actuator mounting plate
- 1221M-3** Standard factory sleeve (caulked to UL requirements) 16" long x 20 ga. (406 x 1.0).
- 1221M-3** Non-standard sleeve. Specify \_\_\_\_\_ length \_\_\_\_\_ ga. Available up to 36" (914) dependent upon wall thickness and 10 through 20 ga. (3.5 through 1.0).



Wall Thickness	Minimum Sleeve Length
4 (102)	16 (406)
8 (203)	20 (508)
12 (305)	24 (610)
16 (406)	28 (711)

**LEAKAGE CLASS/ELEVATED TEMPERATURE: I @ 250°F**

**DYNAMIC VELOCITY/PRESSURE RATING: 24 2000 fpm @ 4" w.g.**

**ACTUATOR SELECTION:**

- Electric
- Pneumatic

**ACTUATOR LOCATION:**

- External
- Internal (in the airstream)

**ACTUATOR FAIL POSITION: Closed.**

**OPTIONS:**

- BS** Stainless steel bearings
- MLS-300** Position indicator switch pack
- MLS-400** Electric Fire Sensor (Re-openable control system). Includes dual heat sensors (165°F and 250°F) and position indicator switch pack.
- QS1** Quick-set retaining angle (one side)
- QS2** Quick-set retaining angles (two sides)
- TDF1** Flange (one end) } (20 or 22 ga.)
- TDF2** Flange (both ends) } sleeves only

For installation instructions, see IOM-1220INST.  
 Dimensions are in inches (mm).

**SCHEDULE TYPE:**

**PROJECT:**

**ENGINEER:**

**CONTRACTOR:**

DATE	B SERIES	SUPERSEDES	DRAWING NO.
5 - 7 - 12	1200	8 - 21 - 08	1220M-3-1



**MODULATING COMBINATION FIRE/SMOKE DAMPER**  
**AIRFOIL BLADE • HIGH PERFORMANCE**  
**3 HR. LABEL • ULTRA-LOW LEAKAGE**  
**MODEL: 1222M-3 (TYPE B SLEEVE ENCLOSURE)**



**FOR DUCTS UNDER 8" (203) IN HEIGHT AND 8" (203) OR MORE IN WIDTH**

**QUALIFICATIONS:**

- **UL 555 & CAN/ULC-S112 CLASSIFIED DYNAMIC FIRE DAMPER** 3 hr. Label (File #'s R9492 & R19569).
- **UL 555S CLASSIFIED SMOKE DAMPER (File # R9492)** Leakage Class I at 250°F elevated temperature.
- **City of New York. MEA #366-03-M.**
- **California State Fire Marshal: Fire Damper Listing No. 3225-0935:106.**
- **Meets NFPA 80, 90A, 92A, 92B, 101 and 105 as well as IBC and NBC (Canada) Building Code requirements.**
- **Maximum velocity: 2000 fpm @ 4" w.g.**

The 1222M-3 Series modulating dampers are classified for use as a volume control damper in applications where building codes require both a fire damper for the protection of ductwork penetrations in walls or floors that have a fire resistance rating of up to 4 hours and also require a leakage rated damper for operational smoke control in static or dynamic smoke management systems.

The 1222M-3 Series has been especially designed and tested to provide premium performance. It offers the lowest leakage class available and is qualified for installation with airflow in either direction and inverted mounting. Airfoil blade design and elimination of blade sills, top and bottom, provide a low pressure drop design.

Unique, inter-locking double skin blade design provides flame and smoke seal under fire conditions.

**STANDARD SPECIFICATION:**

- Frame:** 5" x 7/8" x 16 ga. (127 x 22 x 1.6) galvanized steel hat channel.  
**Blades:** 14 ga. (2.0) equivalent galvanized steel formed airfoil on 5 1/2" (140) centers.  
**Linkage:** Concealed in frame. 12 ga. (2.7) plated steel.  
**Bearings:** 1/2" (13) dia. self-lubricating oilite bronze.  
**Axles:** 1/2" (13) dia. plated steel double bolted to blades.  
**Jackshaft:** 1/2" (13) dia. cadmium plated steel.  
**Jamb Seals:** Stainless steel.

**Heat Responsive Device (Controlled Closure):**

ERL (Electric Resettable Link) is standard on dampers with electric actuators: 250°F (121°C) standard. 165°F (74°C) and 212°F (100°C) available.

PRL (Pneumatic Replaceable Link) is standard on dampers with pneumatic actuators: 212°F (100°C) standard. 165°F (74°C) available.

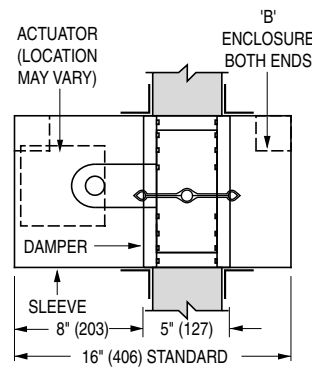
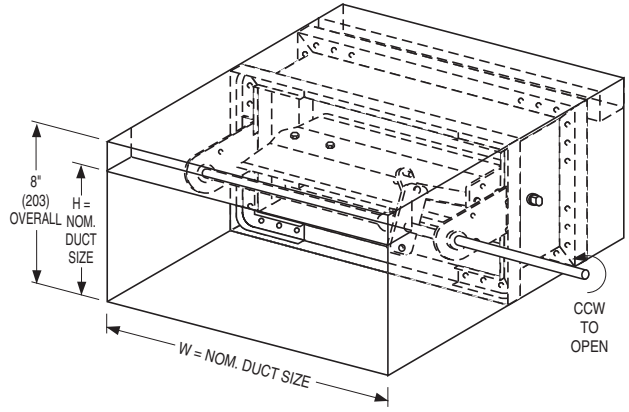
**Sizes (Duct W x H):**

Velocity/ Pressure Rating	Elevated Temp. °F	Minimum		Maximum		
		Single Section		Single Section		Multiple Section
		Vertical/Horizontal	Vertical	Horizontal	Horizontal	Vertical
24	250	8" x 4" (203 x 102) (Overall damper height is 8" [203])	36" x 7 1/2" (914 x 191)	32" x 7 1/2" (813 x 191)	120" x 7 1/2" (3048 x 191)	(maximum each section 30" x 7 1/2" [762 x 191])

**Note:** Duct sizes less than 8" (203) in width require a Type 'C' enclosure (Model 1223M-3).

**SLEEVE/ENCLOSURE SELECTION:**

- 1222M-3** Std. factory sleeve (caulked to UL requirements) 16" long x 20 ga. (406 x 1.0).
- 1222M-3** Non-standard sleeve. Specify \_\_\_\_\_ length \_\_\_\_\_ ga. Available up to 36" (914) dependent upon wall thickness and 10 through 20 ga. (3.5 through 1.0).



Wall Thickness	Minimum Sleeve Length
4 (102)	16 (406)
8 (203)	20 (508)
12 (305)	24 (610)
16 (406)	28 (711)

**LEAKAGE CLASS/ELEVATED TEMPERATURE:**  
**I @ 250°F**

**DYNAMIC VELOCITY/PRESSURE RATING:**  
**24 2000 fpm @ 4" w.g.**

**ACTUATOR SELECTION:**

- Electric**
- Pneumatic**

**ACTUATOR LOCATION:** External.

**ACTUATOR FAIL POSITION:** Closed.

**OPTIONS:**

- BS** Stainless steel bearings
- MLS-300** Position indicator switch pack
- MLS-400** Electric Fire Sensor (Re-openable control system). Includes dual heat sensors (165°F and 250°F) and position indicator switch pack.
- QS1** Quick-set retaining angle (one side)
- QS2** Quick-set retaining angles (two sides)

For installation instructions, see IOM-1220INST.

Dimensions are in inches (mm).

**SCHEDULE TYPE:**

**PROJECT:**

**ENGINEER:**

**CONTRACTOR:**

**DATE**

**B SERIES**

**SUPERSEDES**

**DRAWING NO.**

5 - 7 - 12

1200

8 - 21 - 08

1220M-3-2



**MODULATING COMBINATION FIRE/SMOKE DAMPER**  
**AIRFOIL BLADE • HIGH PERFORMANCE**  
**3 HR. LABEL • ROUND DUCT CONNECTION**  
**MODEL: 1223M-3 (TYPE C SLEEVE ENCLOSURE)**



**QUALIFICATIONS:**

- **UL 555 & CAN/ULC-S112 CLASSIFIED DYNAMIC FIRE DAMPER** 3 hr. Label (File #'s R9492 & R19569).
- **UL 555S CLASSIFIED SMOKE DAMPER (File # R9492)** Leakage Class I at 250°F elevated temperature.
- **City of New York. MEA #366-03-M.**
- **California State Fire Marshal: Fire Damper Listing No. 3225-0935:106.**
- **Meets NFPA 80, 90A, 92A, 92B, 101 and 105 as well as IBC and NBC (Canada) Building Code requirements.**
- **Maximum velocity: 2000 fpm @ 4" w.g.**

The 1220M-3 Series modulating dampers are classified for use as a volume control damper in applications where building codes require both a fire damper for the protection of ductwork penetrations in walls or floors that have a fire resistance rating of up to 4 hours and also require a leakage rated damper for operational smoke control in static or dynamic smoke management systems.

The 1220M-3 Series has been especially designed and tested to provide premium performance. It offers the lowest leakage class available and is qualified for installation with airflow in either direction and inverted mounting. Airfoil blade design and elimination of blade sills, top and bottom, provide a low pressure drop design.

Unique, inter-locking double skin blade design provides flame and smoke seal under fire conditions.

**STANDARD SPECIFICATION:**

- Frame:** 5" x 7/8" x 16 ga. (127 x 22 x 1.6) galvanized steel hat channel.
- Blades:** 14 ga. (2.0) equivalent galvanized steel formed airfoil on 5 1/2" (140) centers. Opposed action.
- Linkage:** Concealed in frame. 12 ga. (2.7) plated steel.
- Bearings:** 1/2" (13) dia. self-lubricating oilite bronze.
- Axles:** 1/2" (13) dia. plated steel double bolted to blades.
- Jackshaft:** 1/2" (13) dia. cadmium plated steel.
- Jamb Seals:** Stainless steel.

**Heat Responsive Device (Controlled Closure):**

ERL (Electric Resettable Link) is standard on dampers with electric actuators: 250°F (121°C) standard. 165°F (74°C) and 212°F (100°C) available.

PRL (Pneumatic Replaceable Link) is standard on dampers with pneumatic actuators: 212°F (100°C) standard. 165°F (74°C) available.

**Sizes (Duct Diameter):**

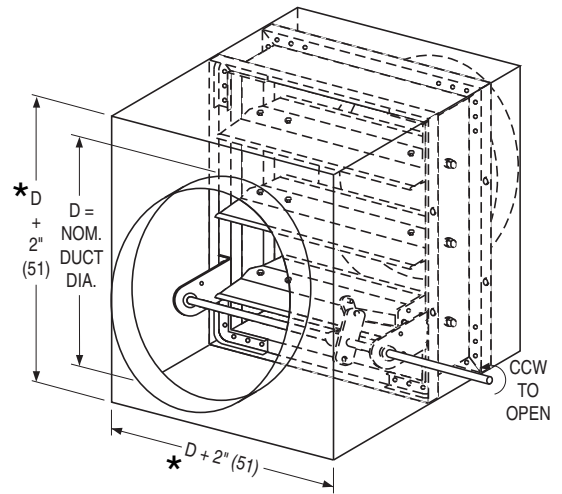
Velocity/ Pressure Rating	Elevated Temp. °F	Minimum		Maximum		
		Single Section		Multiple Section		
		Vertical/Horizontal	Vertical	Horizontal	Vertical	
24	250	4" (102) dia. (Overall damper size is 8" x 8" [203 x 203] min.)		34" (864) dia.	30" (762) dia.	94" (2388) dia.

**SLEEVE/ENCLOSURE SELECTION:**

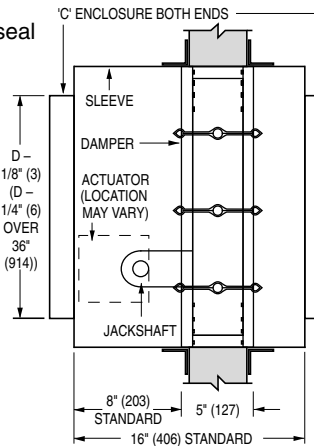
- 1223M-3** Standard factory sleeve (caulked to UL requirements) 16" long x 20 ga. (406 x 1.0).
- 1223M-3** Non-standard sleeve. Specify \_\_\_\_\_ length \_\_\_\_\_ ga. Available up to 36" (914) dependent upon wall thickness and 10 through 20 ga. (3.5 through 1.0).

**LEAKAGE CLASS/ELEVATED TEMPERATURE: I @ 250°F**

**DYNAMIC VELOCITY/PRESSURE RATING: 24 2000 fpm @ 4" w.g.**



\* or 8" (203) min.



Wall Thickness	Minimum Sleeve Length
4 (102)	16 (406)
8 (203)	20 (508)
12 (305)	24 (610)
16 (406)	28 (711)

**ACTUATOR SELECTION:**

- Electric**       **Pneumatic**

**ACTUATOR LOCATION:**

- External**       **Internal** (in the airstream)

**ACTUATOR FAIL POSITION: Closed.**

**OPTIONS:**

- BS** Stainless steel bearings
- MLS-300** Position indicator switch pack
- MLS-400** Electric Fire Sensor (Re-openable control system). Includes dual heat sensors (165°F and 250°F) and position indicator switch pack.
- QS1** Quick-set retaining angle (one side)
- QS2** Quick-set retaining angles (two sides)

For installation instructions, see IOM-1220INST.

Dimensions are in inches (mm).

**SCHEDULE TYPE:**

**PROJECT:**

**ENGINEER:**

**CONTRACTOR:**

**DATE**

**B SERIES**

**SUPERSEDES**

**DRAWING NO.**

5 - 7 - 12

1200

8 - 21 - 08

1220M-3-3



**MODULATING COMBINATION FIRE/SMOKE DAMPER**  
**AIRFOIL BLADE • HIGH PERFORMANCE**  
 3 HR. LABEL • SQ., RECT. OR OVAL DUCT CONNECTION  
**MODEL: 1223M-3 (TYPE C SLEEVE ENCLOSURE)**



**QUALIFICATIONS:**

- UL 555 & CAN/ULC-S112 CLASSIFIED DYNAMIC FIRE DAMPER 3 hr. Label (File #'s R9492 & R19569).
- UL 555S CLASSIFIED SMOKE DAMPER (File # R9492) Leakage Class I at 250°F elevated temperature.
- City of New York. MEA #366-03-M.
- California State Fire Marshal: Fire Damper Listing No. 3225-0935:106.
- Meets NFPA 80, 90A, 92A, 92B, 101 and 105 as well as IBC and NBC (Canada) Building Code requirements.
- Maximum velocity: 2000 fpm @ 4" w.g.

The 1220M-3 Series modulating dampers are classified for use as a volume control damper in applications where building codes require both a fire damper for the protection of ductwork penetrations in walls or floors that have a fire resistance rating of up to 4 hours and also require a leakage rated damper for operational smoke control in static or dynamic smoke management systems.

The 1220M-3 Series has been especially designed and tested to provide premium performance. It offers the lowest leakage class available and is qualified for installation with airflow in either direction and inverted mounting. Airfoil blade design and elimination of blade sills, top and bottom, provide a low pressure drop design.

Unique, inter-locking double skin blade design provides flame and smoke seal under fire conditions.

**STANDARD SPECIFICATION:**

**Frame:** 5" x 7/8" x 16 ga. (127 x 22 x 1.6) galvanized steel hat channel.

**Blades:** 14 ga. (2.0) equivalent galvanized steel formed airfoil on 5 1/2" (140) centers. Opposed action.

**Linkage:** Concealed in frame. 12 ga. (2.7) plated steel.

**Bearings:** 1/2" (13) dia. self-lubricating oilite bronze.

**Axles:** 1/2" (13) dia. plated steel double bolted to blades.

**Jackshaft:** 1/2" (13) dia. cadmium plated steel.

**Jamb Seals:** Stainless steel.

**Heat Responsive Device (Controlled Closure):**

ERL (Electric Resettable Link) is standard on dampers with electric actuators: 250°F (121°C) standard. 165°F (74°C) and 212°F (100°C) available.

PRL (Pneumatic Replaceable Link) is standard on dampers with pneumatic actuators: 212°F (100°C) standard. 165°F (74°C) available.

**Sizes (Duct W x H):**

Velocity/ Pressure Rating	Elevated Temp. °F	Minimum				Maximum	
		Single Section		Single Section		Multiple Section	
		Vertical/Horizontal		Vertical	Horizontal	Vertical	
24	250	4" x 4" (102 x 102) (Overall damper size is 8" x 8" [203 x 203] min.)		34" x 46" (864 x 1168)	30" x 46" (762 x 1168)	118" x 94" (2997 x 2388) (maximum each section 30" x 48" [762 x 1219])	

**SLEEVE/ENCLOSURE SELECTION:**

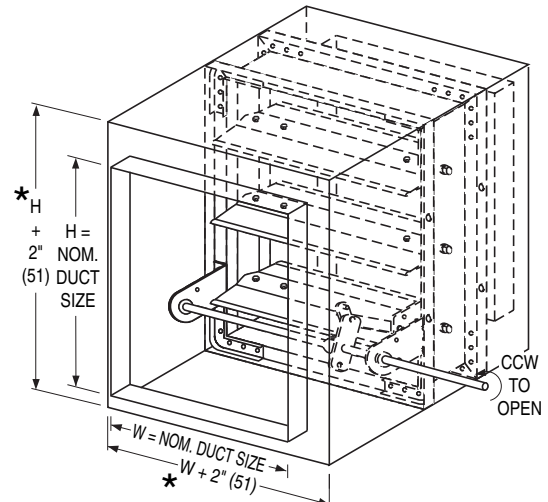
- 1223M-3 Standard factory sleeve (caulked to UL requirements) 16" long x 20 ga. (406 x 1.0).
- 1223M-3 Non-standard sleeve. Specify \_\_\_\_\_ length \_\_\_\_\_ ga. Available up to 36" (914) dependent upon wall thickness and 10 through 20 ga. (3.5 through 1.0).

**LEAKAGE CLASS/ELEVATED TEMPERATURE: I @ 250°F**

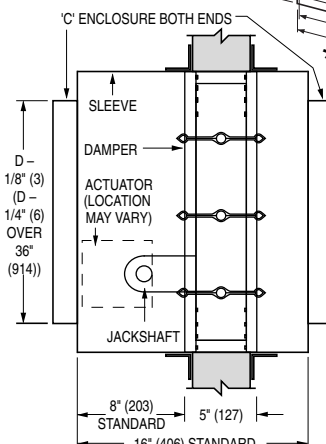
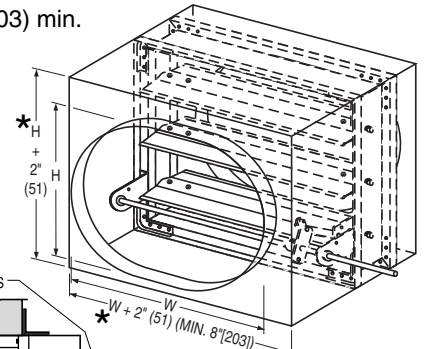
**DYNAMIC VELOCITY/PRESSURE RATING: 24** 2000 fpm @ 4" w.g.

**ACTUATOR SELECTION:**  Electric  Pneumatic

**ACTUATOR LOCATION:**  External  Internal (in the airstream)



\* or 8" (203) min.



Wall Thickness	Minimum Sleeve Length
4 (102)	16 (406)
8 (203)	20 (508)
12 (305)	24 (610)
16 (406)	28 (711)

**ACTUATOR FAIL POSITION: Closed.**

**OPTIONS:**

- BS** Stainless steel bearings
- MLS-300** Position indicator switch pack
- MLS-400** Electric Fire Sensor (Re-openable control system). Includes dual heat sensors (165°F and 250°F) and position indicator switch pack.
- QS1** Quick-set retaining angle (one side)
- QS2** Quick-set retaining angles (two sides)

**SCHEDULE TYPE:** \_\_\_\_\_

**PROJECT:** \_\_\_\_\_

**ENGINEER:** \_\_\_\_\_

**CONTRACTOR:** \_\_\_\_\_

For installation instructions, see IOM-1220INST.  
 Dimensions are in inches (mm).

DATE	B SERIES	SUPERSEDES	DRAWING NO.
5 - 7 - 12	1200	8 - 21 - 08	1220M-3-4



**MODULATING COMBINATION FIRE/SMOKE DAMPER**  
**AIRFOIL BLADE • HIGH PERFORMANCE**  
**1 1/2 HR. LABEL • SQUARE, RECT. OR OVAL**  
**DUCT CONNECTION**  
**MODEL: 1223M (TYPE C SLEEVE ENCLOSURE)**



**QUALIFICATIONS:**

- **UL 555 & CAN/ULC-S112 CLASSIFIED DYNAMIC FIRE DAMPER** 1 1/2 hr. Label (File #'s R9492 & R19569).
- **UL 555S CLASSIFIED SMOKE DAMPER (File # R9492)** Leakage Class I at 250°F elevated temperature.
- **City of New York. MEA #366-03-M.**
- **California State Fire Marshal: Fire Damper Listing No. 3225-0935:106.**
- **Meets NFPA 80, 90A, 92A, 92B, 101 and 105 as well as IBC and NBC (Canada) Building Code requirements.**
- **Maximum velocity: 2000 fpm @ 4" w.g.**

The 1220M Series modulating dampers are classified for use as a volume control damper in applications where building codes require both a fire damper for the protection of ductwork penetrations in walls or floors that have a fire resistance rating of up to 2 hours and a leakage rated damper for operational smoke control in static or dynamic smoke management systems.

The 1220M Series has been especially designed and tested to provide premium performance. It offers the lowest leakage class available and is qualified for installation with airflow in either direction and inverted mounting. Airfoil blade design and elimination of blade sills, top and bottom, provide a low pressure drop design.

Unique, inter-locking double skin blade design provides flame and smoke seal under fire conditions.

**STANDARD SPECIFICATION:**

**Frame:** 5" x 7/8" x 16 ga. (127 x 22 x 1.6) galvanized steel hat channel.

**Blades:** 14 ga. (2.0) equivalent galvanized steel formed airfoil on 5 1/2" (140) centers. Opposed action.

**Linkage:** Concealed in frame. 12 ga. (2.7) plated steel.

**Bearings:** 1/2" (13) dia. self-lubricating oilite bronze.

**Axles:** 1/2" (13) dia. plated steel double bolted to blades.

**Jackshaft:** 1/2" (13) dia. cadmium plated steel.

**Jamb Seals:** Stainless steel.

**Heat Responsive Device (Controlled Closure):**

ERL (Electric Resettable Link) is standard on dampers with electric actuators: 250°F (121°C) standard. 165°F (74°C) and 212°F (100°C) available.

PRL (Pneumatic Replaceable Link) is standard on dampers with pneumatic actuators: 212°F (100°C) standard. 165°F (74°C) available.

**Sizes (Duct W x H):**

Velocity/ Pressure Rating	Elevated Temp. °F	Minimum		Maximum		
		Single Section		Single Section		Multiple Section
		Vertical/Horizontal	Vertical	Horizontal	Vertical	Horizontal
24	250	4" x 4" (102 x 102)	34" x 46" (864 x 1168)	30" x 46" (762 x 1168)	142" x 94" (3607 x 2388)	126" x 94" (3200 x 2388)

**SLEEVE/ENCLOSURE SELECTION:**

- 1223M** Standard factory sleeve (caulked to UL requirements) 16" long x 20 ga. (406 x 1.0).
- 1223M** Non-standard sleeve. Specify \_\_\_\_\_ length \_\_\_\_\_ ga. Available up to 36" (914) dependent upon wall thickness and 10 through 20 ga. (3.5 through 1.0).

**LEAKAGE CLASS/ELEVATED TEMPERATURE: I @ 250°F**

**DYNAMIC VELOCITY/PRESSURE RATING: 24** 2000 fpm @ 4" w.g.

**ACTUATOR SELECTION:**  **Electric**  **Pneumatic**

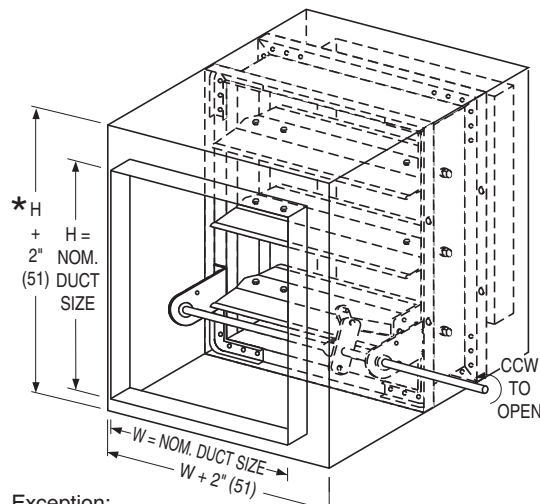
**ACTUATOR LOCATION:**  **External** (std.)  **Internal** (in the airstream)

**SCHEDULE TYPE:**

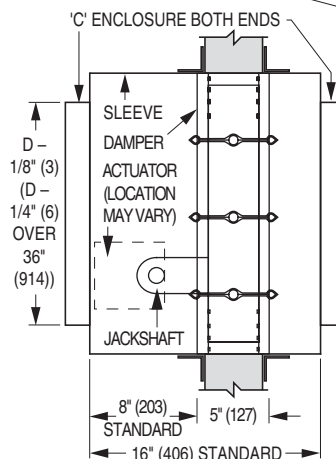
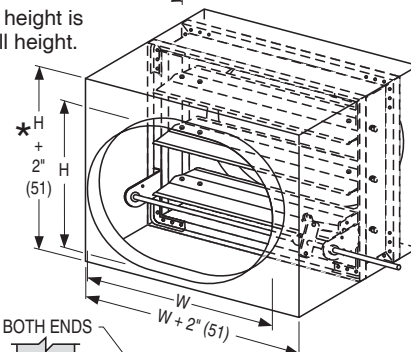
**PROJECT:**

**ENGINEER:**

**CONTRACTOR:**



Exception:  
\*5" (127) duct height is  
8" (203) overall height.



Wall Thickness	Minimum Sleeve Length
4 (102)	16 (406)
8 (203)	20 (508)
12 (305)	24 (610)
16 (406)	28 (711)

**ACTUATOR FAIL POSITION: Closed.**  
**OPTIONS:**

- BS** Stainless steel bearings
- MLS-300** Position indicator switch pack
- MLS-400** Electric Fire Sensor (Re-openable control system). Includes dual heat sensors (165°F and 250°F) and position indicator switch pack.
- QS1** Quick-set retaining angle (one side)
- QS2** Quick-set retaining angles (two sides)

For installation instructions, see IOM-1220INST.  
 Dimensions are in inches (mm).

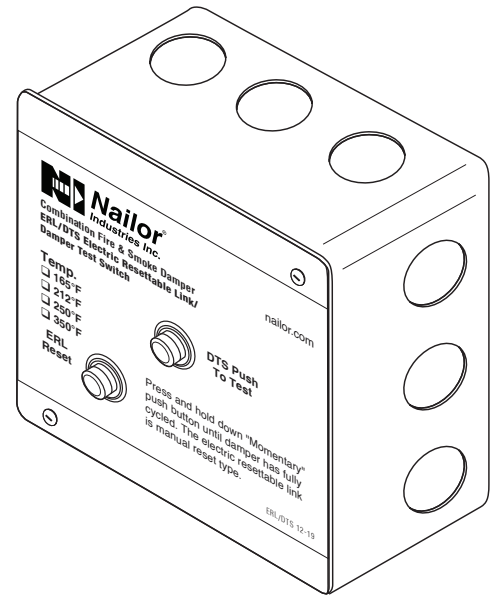
DATE	B SERIES	SUPERSEDES	DRAWING NO.
9 - 1 - 23	1200	5 - 7 - 12	1220M-4



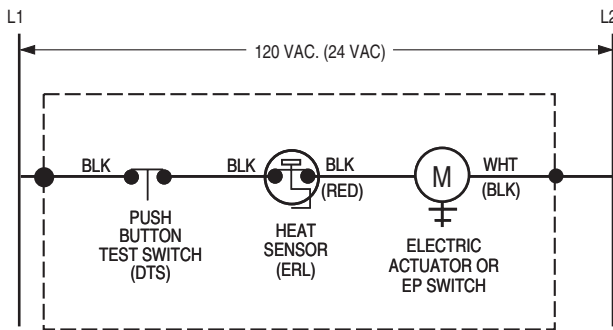
The DTS (Damper Test Switch) is an optional "momentary" push button test switch available on all Nailor smoke and combination fire/smoke dampers. The DTS provides the ability to "cycle test" the damper by pushing and holding down the button until the damper has cycled and closure has been visually verified, either by inspecting the damper through the access door or by confirmation at a remote control panel when equipped with the optional MLS-300 position indicator.

The DTS is mounted right on the damper and enables a single maintenance person to test and cycle the damper, eliminating the need for help from another person in the control room.

When a combination fire/smoke damper is ordered, the DTS is combined with the ERL (Electric Resettable Link), in a common enclosure.



### WIRING DIAGRAMS:



MOUNTED ON DAMPER (FACTORY WIRING TERMINATES AT SPLICE POINTS INDICATED INSIDE 4" x 4" ELECTRICAL BOX)

Figure 1. DTS/ERL Damper Test Switch with Electric Resettable Link

### Belimo Actuator Aux. Switch Wiring Connections

Model Series	Open (OP)	Closed (CL)
FSTF	Orange / Gray	Violet / Red
FSLF / FSAFA	Gray / Gray	Violet / Violet
FSNF / FSAFB	White S4 / S6	White S1 / S2

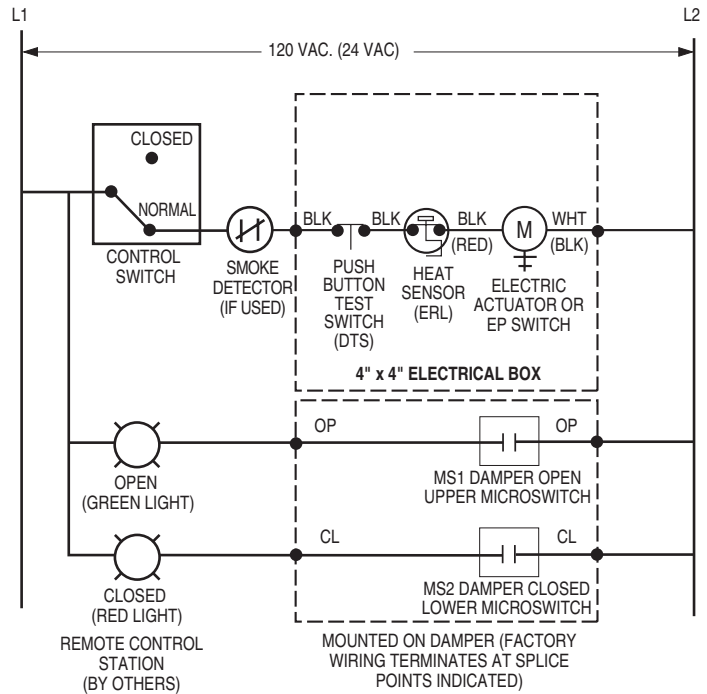


Figure 2. DTS/ERL with MLS-300 Belimo (actuator aux. switches) Position Indicator Package

SCHEDULE TYPE

PROJECT

ENGINEER

CONTRACTOR

DATE

B SERIES

SUPERSEDES

DRAWING NO.

9 - 3 - 20

FD-ACC

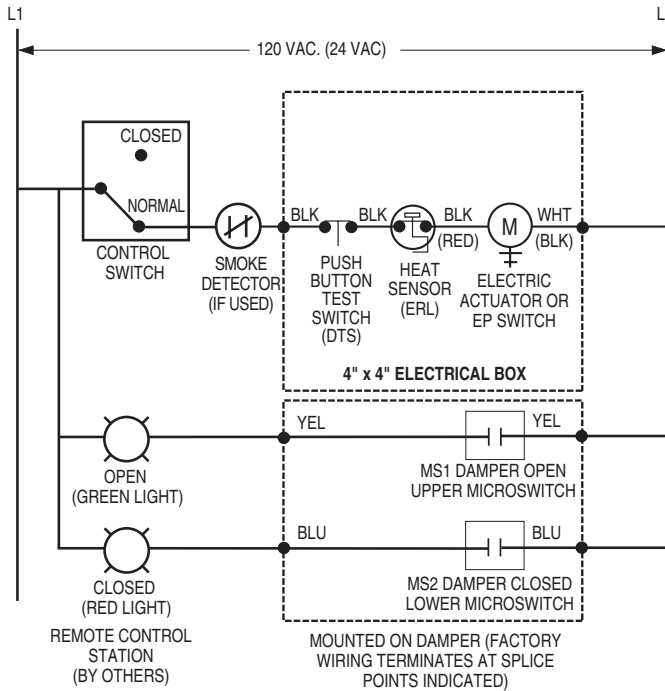
3 - 29 - 18

DTS

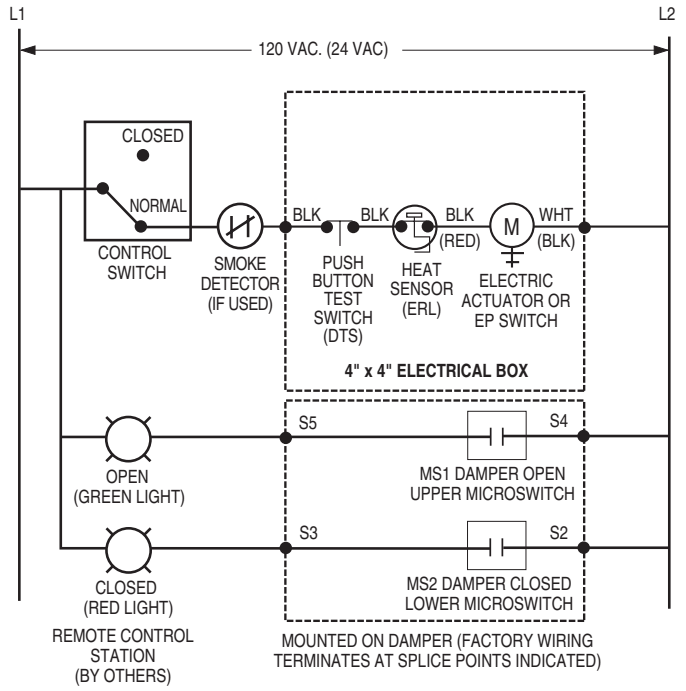
### WIRING DIAGRAMS:

#### Honeywell Actuator Aux. Switch Wiring Connections

Model Series	Open (OP)	Closed (CL)
MSXX04	Yellow / Yellow	Blue / Blue
MSXX20	Yellow / Yellow	Blue / Blue

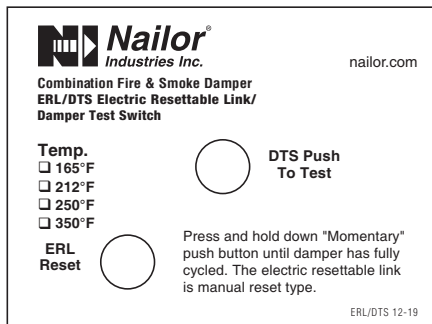


**Figure 3. DTS/ERL with MLS-300 Nailor or Honeywell (actuator aux. switches) Position Indicator Package**

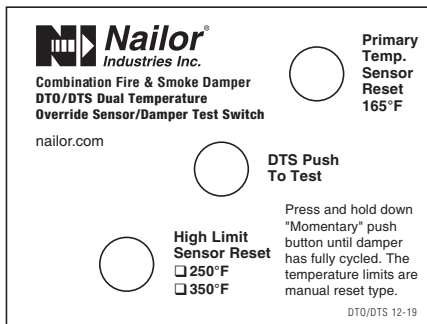


**Figure 4. DTS/ERL with MLS-300 Siemens GJD Series (actuator auxiliary switches) Position Indicator Package**

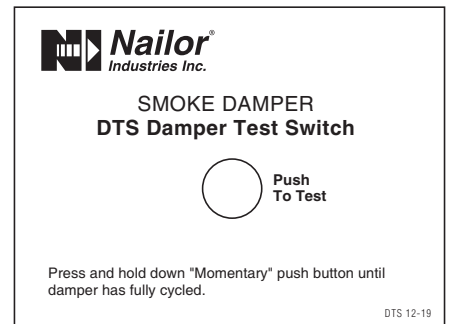
### DTS LABEL VARIATIONS:



**ERL/DTS Combination Fire/Smoke Damper**



**DTO/DTS Combination Fire/Smoke Damper**



**DTS Smoke Damper**

SCHEDULE TYPE

PROJECT

ENGINEER

CONTRACTOR

**"QUICK-SET" RETAINING ANGLES BOTH SIMPLIFY AND SPEED INSTALLATION,  
 SAVING BOTH TIME AND MONEY.**

**BENEFITS:**

- One piece angles are fastened together in the corners. Only two sets of angles to handle per damper (rather than four separate angles per side).
- Angles are shipped with damper - no sorting or matching.
- Provided with pre-drilled fastening holes on 2" (51) centers to ensure correct angle/sleeve attachment.
- Factory fabricated by Nailor to suit the individual fire damper.
- Reduced cost when compared to conventional retaining angles.
- Dampers can ship directly to the job site complete with all necessary installation sheet metal hardware (saves on double handling at contractor's shop).
- Help ensure a correct installation as per U.L. approved installation instructions.

The majority of installing contractors view fire damper installation as a costly time consuming and troublesome procedure. Eight conventional angles must be custom fabricated for each damper either in a sheet metal shop or at the job site and sized to suit each individual damper. Invariably, they are mislaid or lost and must be matched to each factory supplied damper.

The Nailor "Quick-Set" solution solves the majority of problems. They are pre-formed to fit and ship with the individual damper for ultimate convenience. "Quick-Set" angles are supplied with correctly spaced pre-drilled screw-holes to ensure a quick, easy and accurate installation for all integral sleeve Nailor fire and combination fire/smoke dampers - no measuring required.

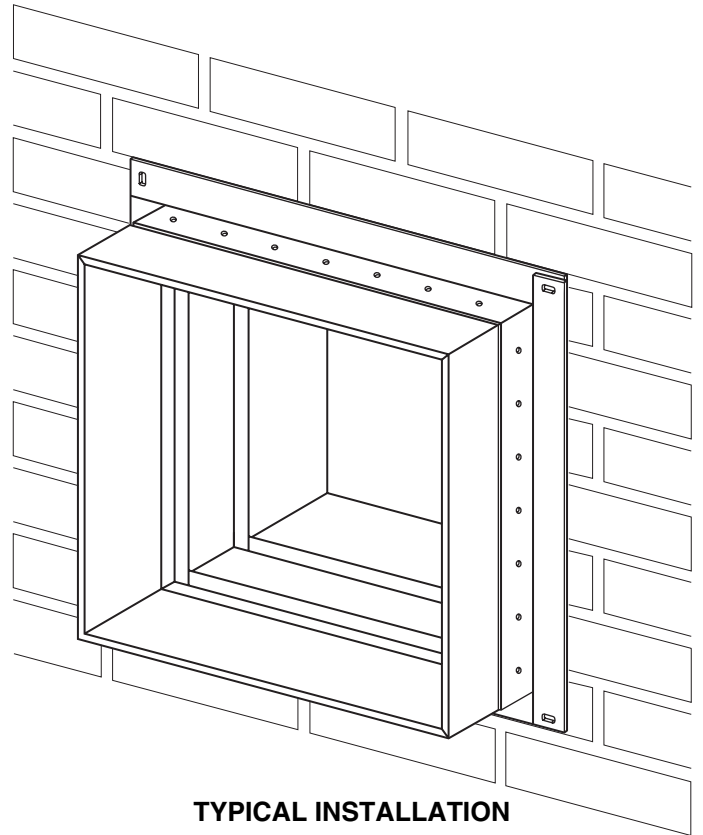
"Quick-Set" retaining angles provide the "complete" installation package. Simple, fast, convenient.

**MODELS:**

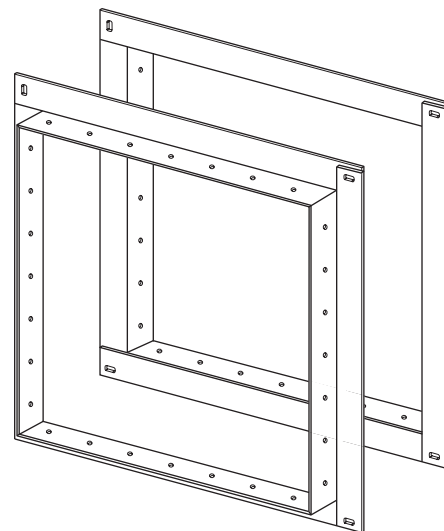
Nailor "Quick-Set" retaining angles are an accessory option for all dampers ordered with factory sleeves.

**QS2:** Two sides (pair). For standard installations where angles are installed on both sides of the fire partition.

**QS1:** One side (single set). For use in single side retaining angle installations and with grille mount and "out of wall" damper models.



**TYPICAL INSTALLATION**

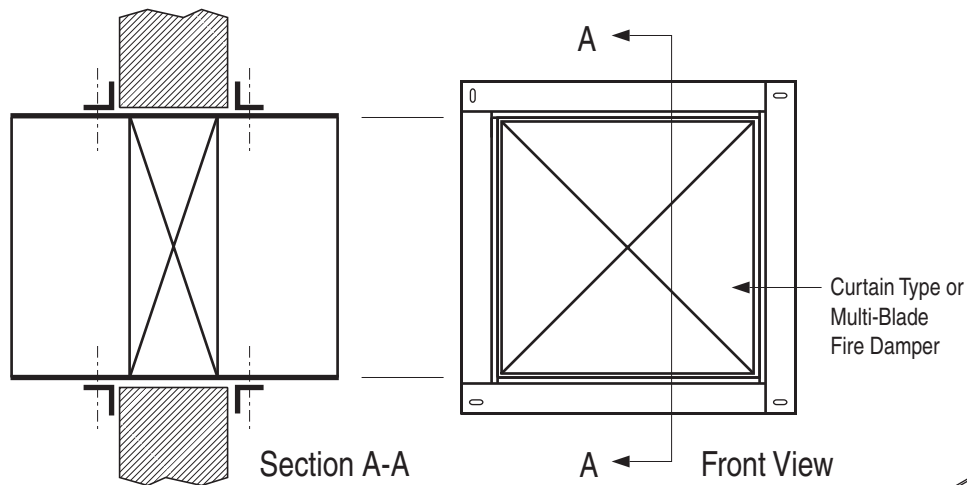


**TYPICAL PAIR OF PRE-ASSEMBLED  
 QUICK-SET' RETAINING ANGLES**

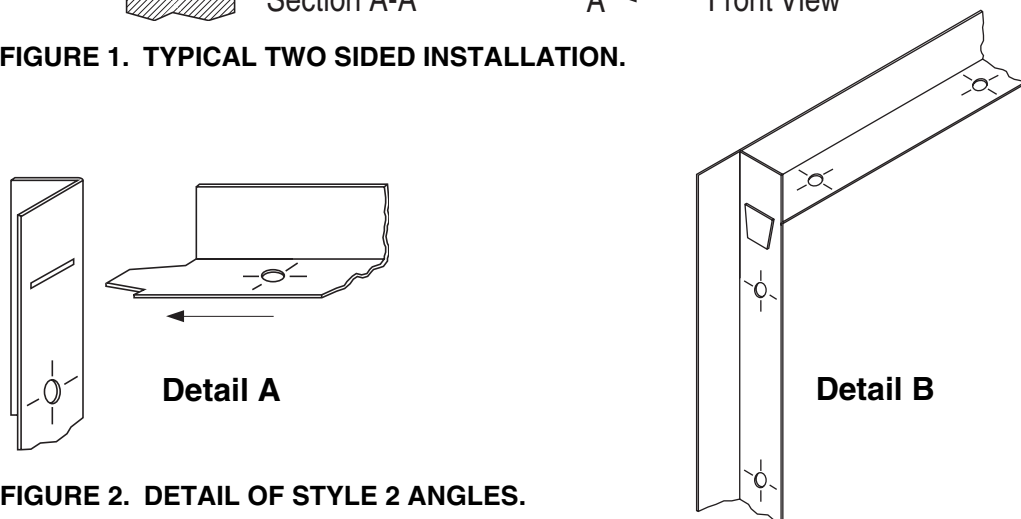


<b>SCHEDULE TYPE:</b>
<b>PROJECT:</b>
<b>ENGINEER:</b>
<b>CONTRACTOR:</b>

Page 1 of 2 Dimensions are in inches (mm).			
<b>DATE</b>	<b>B SERIES</b>	<b>SUPERSEDES</b>	<b>DRAWING NO.</b>
2 - 26 - 09	FD-ACC	6 - 5 - 03	QSRA



**FIGURE 1. TYPICAL TWO SIDED INSTALLATION.**



**FIGURE 2. DETAIL OF STYLE 2 ANGLES.**

**APPLICATION:**

The Nailor Quick-Set Retaining Angle System may be used in lieu of conventional retaining angles on all Nailor Fire and Combination Fire/Smoke Dampers.

Quick-Set angles are supplied in one of two styles, dependent upon fire resistance label, damper size and installation method.

**Style 1:** 1 1/2" x 1 1/2" x 20 ga. (38 x 38 x 1.0) Four sides are connected together with rivets in three corners.

Standard for the majority of applications with the following limitations:

- 1 1/2 hour label fire dampers.
- Maximum Size: 36" x 36" (914 x 914)
- Two sided installation only

**Style 2:** 1 1/2" x 1 1/2" x 16 ga. (38 x 38 x 1.6) Slot and tab design. The retaining angle assembly for each side has four angles, each with a tab end and a slot end (Detail A).

The tabs are to be inserted into the slots and knocked down either before or after fastening to the sleeve (Detail B).

- 1 1/2 or 3 hour label fire dampers
- Maximum Size: 90" x 48" (2286 x 1219) or 48" x 90" (1219 x 2286)
- Single side (1 1/2 hour only. Refer to Single Side Retaining Angles Supplementary Installation Instructions for size limitations) or two sided installation

**Refer to the Following Installation Instructions:**

Quick-Set Retaining Angles	FDQSRA
Curtain Type Fire Dampers (D)0100 & (D)0500	FDINST
Curtain Type Fire Dampers 0200 & 0500 Thinline	FDTINST
Multi-Blade Fire Dampers 1200 & 1250	MBFDINST
Combination Fire/Smoke Dampers 1220	1220INST
Combination Fire/Smoke Dampers 1270	1270INST
Single Side Retaining Angles	FDSSRAINST

<b>SCHEDULE TYPE:</b>	Page 2 of 2			
<b>PROJECT:</b>	Dimensions are in inches (mm).			
<b>ENGINEER:</b>	<b>DATE</b>	<b>B SERIES</b>	<b>SUPERSEDES</b>	<b>DRAWING NO.</b>
<b>CONTRACTOR:</b>	2 - 26 - 09	FD-ACC	5 - 5 - 03	QSRA

## PERFORMANCE DATA:

### MODEL SERIES: 1220M - 1 1/2 HOUR LABEL AND 1220M-3 - 3 HOUR LABEL

#### LEAKAGE CLASS:

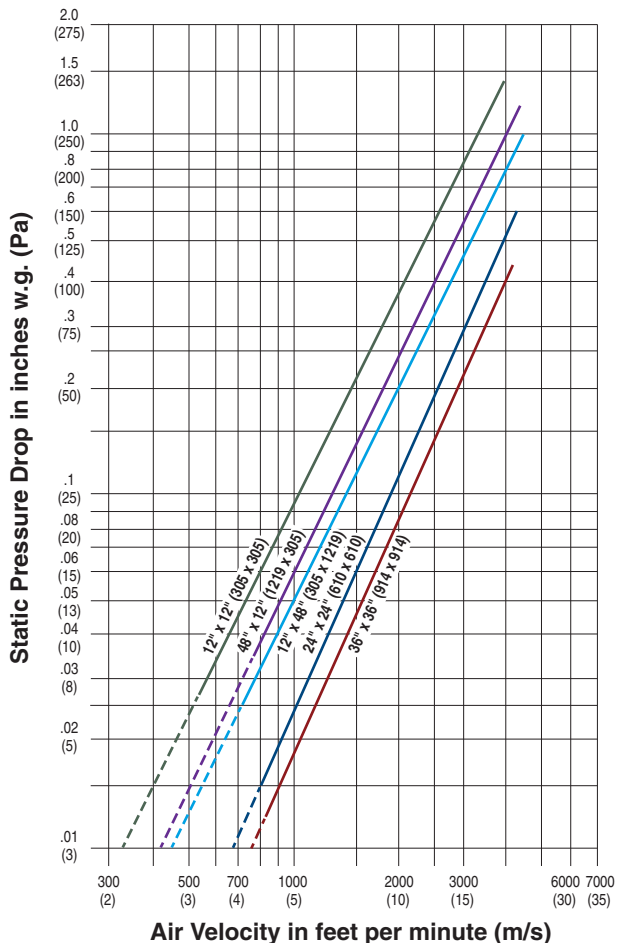
The 1220M Series Modulating Combination Fire/Smoke Damper has been designed and qualified under UL 555S in order to provide maximum system design flexibility. They are available with a Class I (currently the lowest available) leakage rating with all damper/actuator assemblies having been tested successfully at an elevated temperature of 250°F (121°C), dependent on actuator, under airflow of 2000 fpm @ 4" w.g. (10 m/s @ 1 kPa).

The 1220M-3 Series Modulating Combination Fire/Smoke Damper has been designed and qualified under UL 555S in order to provide maximum system design flexibility. They are available with a Class I (currently the lowest available) leakage rating with all damper/actuator assemblies having been tested successfully at an elevated temperature of 250°F (121°C), dependent on actuator, under airflow of 2000 fpm @ 4" w.g. (10 m/s @ 1 kPa).

1220M Series - Maximum Performance Ratings	
UL 555 Fire Rating	1 1/2 Hour
UL 555S Leakage Rating	Class I
Maximum Velocity	2000 fpm (10 m/s)
Maximum Pressure	4 in. w.g. (1 kPa)
Maximum Temperature	250°F (121°C)

1220M-3 Series - Maximum Performance Ratings	
UL 555 Fire Rating	3 Hour
UL 555S Leakage Rating	Class I
Maximum Velocity	2000 fpm (10 m/s)
Maximum Pressure	4 in. w.g. (1 kPa)
Maximum Temperature	250°F (121°C)

#### PRESSURE DROP:



Pressure drop tested per AMCA Standard 500-D, Figure 5.3.  
Data corrected to standard air density of 0.075 lbs/ft.<sup>3</sup>.