

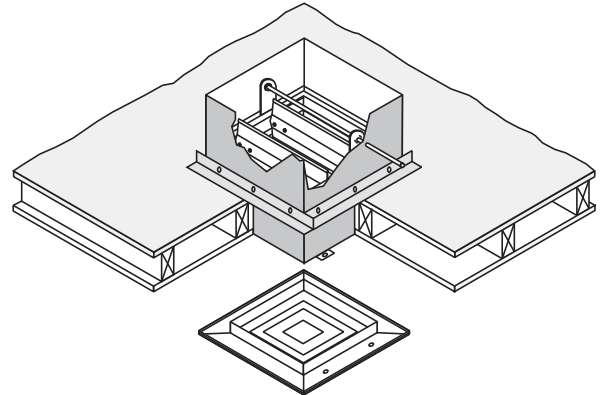

TUNNEL CORRIDOR COMBINATION FIRE/SMOKE DAMPER WITH STEEL GRILLE/DIFFUSER
1 HR. LABEL • AIRFOIL BLADE
MODEL: 1221C-1

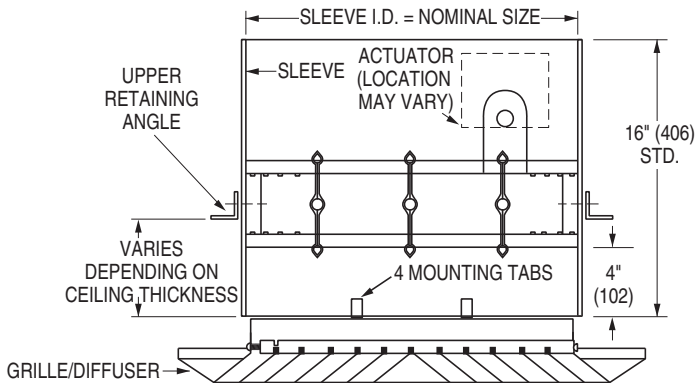

QUALIFICATIONS:

- **UL 555 CLASSIFIED CORRIDOR DAMPER, 1 hr. Fire Resistance Rating (File # R9492).**
- **UL 555S CLASSIFIED SMOKE DAMPER, Class I at 250°F or 350°F elevated temp. (File # R9492).**
- **California State Fire Marshal Listing No. 3225-0935:106.**
- **Meets the requirements of NFPA 90A, NFPA 92A for Fire/Smoke Dampers**
- **Meets the requirements of City of Los Angeles, Uniform Building Code.**
- **Maximum velocity: 2000 fpm @ 4" w.g.**

STANDARD SPECIFICATION:

Frame: 5" x 7/8" x 16 ga. (127 x 22 x 1.6) galvanized steel hat channel.

Blades: 14 ga. (2.0) equivalent galvanized steel formed airfoil on 5 1/2" (140) centers. Opposed action.

Sleeve: 16" x 20 ga. (406 x 1.0) standard.

Upper Retaining Angles: 1 1/2" x 1 1/2" x 16 ga. (38 x 38 x 1.6) galvanized steel (by Nailor).

Linkage: Concealed in frame.

Bearings: 1/2" (13) dia. self-lubricating oilite bronze.

Axles: 1/2" (13) dia. plated steel double bolted to blades.

Jamb Seals: Cambered stainless steel.

Heat Responsive Device (Controlled Closure):

ERL (Electric Resettable Link) is std. on dampers with electric actuators: 250°F (121°C) standard. 165°F (74°C), 212°F (100°C) and 350°F (176°C) available.

PRL (Pneumatic Replaceable Link) is standard on dampers with pneumatic actuators: 212°F (100°C) standard. 165°F (74°C) and 280°F (138°C) available.

Compatible Steel Supply or Return Air Grille/Diffuser (various models available).

Sizes (Duct W x H):

Minimum	Maximum
8" x 8" (203 x 203)	24" x 24" (610 x 610)

BASE MODEL SELECTION:

- 1221C-1** Standard factory sleeve (caulked to UL requirements) 16" long x 20 ga. (406 x 1.0) (18 ga. (1.3) for dampers over 84" (2134) in width).
- 1221C-1** Non-standard sleeve. Specify _____ length _____ ga. Available up to 36" (914) dependent upon wall thickness and 10 through 20 ga. (3.5 through 1.0).

LEAKAGE CLASS / ELEVATED TEMPERATURE:

- I @ 250°F** (Standard)
- I @ 350°F** (Optional)

ACTUATOR SELECTION:

- Electric** **Pneumatic**

Actuators are mounted for Fail Closed (Normally Closed) operation in accordance with code requirements.

ACTUATOR LOCATION:

- Out of airstream** **In the airstream**

OPTIONS:

- BS** Stainless steel bearings.
- MLS-300** Position indicator switch pack.
- MLS-400** Electric Fire Sensor (Re-openable control system). Includes dual heat sensors (165°F and 250°F or 350°F) and position indicator switch pack.

- Non-standard sleeve length or gauge.** Specify: _____ inches (mm) x _____ ga.

- UFM Factory mounted upper retaining angles.** Specify overall ceiling thickness: _____ inches (mm).

- SRT Square-to-Round Transition Collar.** (top of damper) Dia. = _____ .

- Special Features.** Specify: _____ .

GRILLE/DIFFUSER SELECTION:

- Compatible Steel Supply or Return Grille/Diffuser by Nailor. (see attached submittal dwg. for model selection).
- Grille/Diffuser by others.

For installation instructions, see IOM-TCFSDINST.

Dimensions are in inches (mm).

SCHEDULE TYPE:

PROJECT:

ENGINEER:

CONTRACTOR:

DATE

B SERIES

SUPERSEDES

DRAWING NO.

6 - 16 - 16

1220C

5 - 7 - 12

1220C-1



TUNNEL CORRIDOR COMBINATION FIRE/SMOKE DAMPER FOR DUCTED INSTALLATION
 1 HR. LABEL • AIRFOIL BLADE
 MODEL: 1221C-2

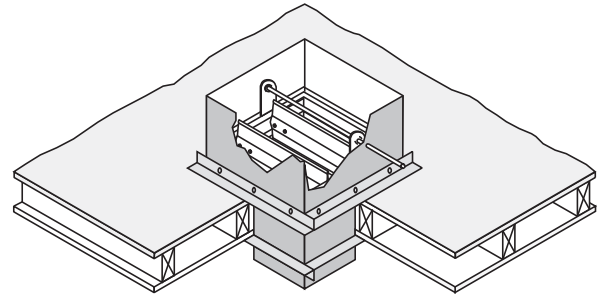
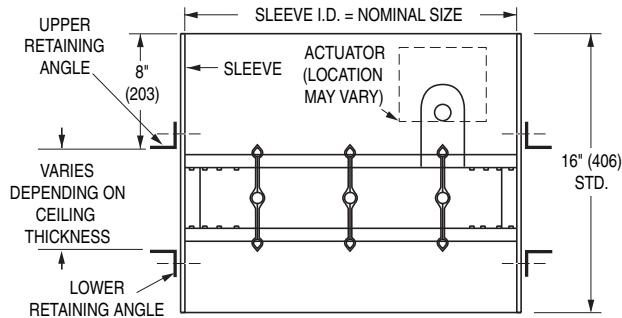

QUALIFICATIONS:

- **UL 555 CLASSIFIED CORRIDOR DAMPER, 1 hr. Fire Resistance Rating (File # R9492).**
- **UL 555S CLASSIFIED SMOKE DAMPER, Class I at 250°F or 350°F elevated temp. (File # R9492).**
- **California State Fire Marshal Listing No. 3225-0935:106.**
- **Meets the requirements of NFPA 90A, NFPA 92A for Fire/Smoke Dampers**
- **Meets the requirements of City of Los Angeles, Uniform Building Code.**
- **Maximum velocity: 2000 fpm @ 4" w.g.**

STANDARD SPECIFICATION:

- Frame:** 5" x 7/8" x 16 ga. (127 x 22 x 1.6) galvanized steel hat channel.
- Blades:** 14 ga. (2.0) equivalent galvanized steel formed airfoil on 5 1/2" (140) centers. Opposed action.
- Sleeve:** 16" x 20 ga. (406 x 1.0) standard.
- Upper Retaining Angles:** 1 1/2" x 1 1/2" x 16 ga. (38 x 38 x 1.6) galvanized steel (by Nailor).
- Lower Retaining Angles:** 1 1/2" x 1 1/2" x 16 ga. (38 x 38 x 1.6) galvanized steel by installing contractor (optionally by Nailor).
- Linkage:** Concealed in frame.
- Bearings:** 1/2" (13) dia. self-lubricating oilite bronze.
- Axles:** 1/2" (13) dia. plated steel double bolted to blades.
- Jamb Seals:** Cambered stainless steel.
- Heat Responsive Device (Controlled Closure):**
 ERL (Electric Resettable Link) is standard on dampers with electric actuators: 250°F (121°C) standard. 165°F (74°C), 212°F (100°C) and 350°F (176°C) available.
 PRL (Pneumatic Replaceable Link) is standard on dampers with pneumatic actuators: 212°F (100°C) standard. 165°F (74°C) and 280°F (138°C) available.

Sizes (Duct W x H):

Minimum	Maximum
8" x 8" (203 x 203)	24" x 24" (610 x 610)

BASE MODEL SELECTION:

- 1221C-2** Standard factory sleeve (caulked to UL requirements) 16" long x 20 ga. (406 x 1.0) (18 ga. (1.3) for dampers over 84" (2134) in width).
- 1221C-2** Non-standard sleeve. Specify _____ length _____ ga. Available up to 36" (914) dependent upon wall thickness and 10 through 20 ga. (3.5 through 1.0).

LEAKAGE CLASS / ELEVATED TEMPERATURE:

- I @ 250°F** (Standard)
- I @ 350°F** (Optional)

ACTUATOR SELECTION:

- Electric** **Pneumatic**

Actuators are mounted for Fail Closed (Normally Closed) operation in accordance with code requirements.

ACTUATOR LOCATION:

- Out of airstream** **In the airstream**

OPTIONS:

- BS** Stainless steel bearings.
- MLS-300** Position indicator switch pack.
- MLS-400** Electric Fire Sensor (Re-openable control system). Includes dual heat sensors (165°F and 250°F or 350°F) and position indicator switch pack.

- Non-standard sleeve length or gauge.**

Specify: _____ inches (mm) x _____ ga.

- UFM Factory mounted upper retaining angles.**

- LNM Lower retaining angles by Nailor.**

(Shipped loose for field attachment).

- Special Features.**

Specify: _____ .

Square-to-Round Transition Collars:

(Factory mounted and caulked to UL requirements).

- SRT** (top of damper) Dia. = _____ .
- SRB** (bottom of damper) Below ceiling for round neck diffuser steel duct/flex duct connection. Dia. = _____ .
- SR2** (top and bottom) Dia. = _____ .

For installation instructions, see IOM-TCFSDINST.

Dimensions are in inches (mm).

SCHEDULE TYPE:

PROJECT:

ENGINEER:

CONTRACTOR:

DATE

B SERIES

SUPERSEDES

DRAWING NO.

6 - 16 - 16

1220C

5 - 7 - 12

1220C-2



TUNNEL CORRIDOR OR COMBINATION FIRE/SMOKE DAMPER
 1 HR. AND 1 1/2 HR. LABEL • AIRFOIL BLADE
 MODEL: 1221C-3



QUALIFICATIONS:

- **UL 555 CLASSIFIED CORRIDOR DAMPER, 1 hr. Fire Resistance Rating (File # R9492).**
- **UL 555 CLASSIFIED FIRE DAMPER, 1 1/2 hr. Fire Resistance Rating (File # R9492).**
- **UL 555S CLASSIFIED SMOKE DAMPER, Class I at 250°F or 350°F elevated temp. (File # R9492).**
- **California State Fire Marshal Listing No. 3225-0935:106.**
- **Meets the requirements of NFPA 80, 90A, 92A, 92B, 101 and 105.**
- **Meets the requirements of City of Los Angeles, Uniform Building Code.**
- **Maximum velocity: 2000 fpm @ 4" w.g.**

Model 1221C-3 is both a 1 hr. rated corridor damper for use in corridor ceilings and a standard 1 1/2 hr. rated combination fire/smoke damper for use in walls and floors. The dual rating makes it ideal for stocking as the unit can be supplied when either type of damper is required by the local customer. Model 1221C-3 is supplied complete with upper retaining angles as well as mounting tabs for use with a steel grille/diffuser. The damper may be installed using the single-side retaining angles method. Lower retaining angles are available for ducted corridor or standard wall/floor combination fire/smoke applications when the two-sided angles installation is utilized.

STANDARD SPECIFICATION:

- Frame:** 5" x 7/8" x 16 ga. (127 x 22 x 1.6) galvanized steel hat channel.
- Blades:** 14 ga. (2.0) equivalent galvanized steel formed airfoil on 5 1/2" (140) centers. Opposed action.
- Sleeve:** 16" x 20 ga. (406 x 1.0) standard.
- Upper Retaining Angles:** 1 1/2" x 1 1/2" x 16 ga. (38 x 38 x 1.6) galvanized steel (by Nailor).
- Lower Retaining Angles:** 1 1/2" x 1 1/2" x 16 ga. (38 x 38 x 1.6) galvanized steel by installing contractor (optionally by Nailor) when required.
- Linkage:** Concealed in frame.
- Bearings:** 1/2" (13) dia. self-lubricating oilite bronze.
- Axles:** 1/2" (13) dia. plated steel double bolted to blades.
- Jamb Seals:** Cambered stainless steel.
- Heat Responsive Device (Controlled Closure):**
 ERL (Electric Resettable Link) is standard on dampers with electric actuators: 250°F (121°C) standard. 165°F (74°C), 212°F (100°C) and 350°F (176°C) available.
 PRL (Pneumatic Replaceable Link) is standard on dampers with pneumatic actuators: 212°F (100°C) standard. 165°F (74°C) and 280°F (138°C) available.

Sizes (Duct W x H):

Minimum	Maximum
8" x 8" (203 x 203)	24" x 24" (610 x 610)

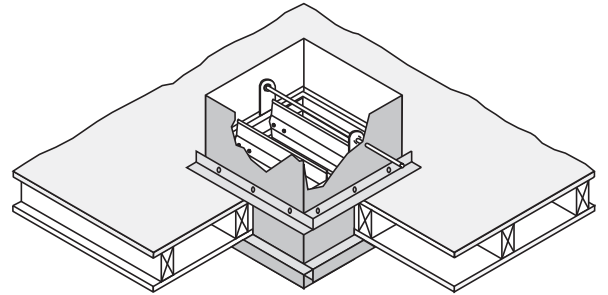

BASE MODEL SELECTION:

- 1221C-3** Standard factory sleeve (caulked to UL requirements) 16" long x 20 ga. (406 x 1.0) (18 ga. (1.3) for dampers over 84" (2134) in width).
- 1221C-3** Non-standard sleeve. Specify _____ length _____ ga. Available up to 36" (914) dependent upon wall thickness and 10 through 20 ga. (3.5 through 1.0).

LEAKAGE CLASS / ELEVATED TEMPERATURE:

- I @ 250°F** (Standard)
- I @ 350°F** (Optional)

ACTUATOR SELECTION:

- Electric** **Pneumatic**

Actuators are mounted for Fail Closed (Normally Closed) operation in accordance with code requirements.

ACTUATOR LOCATION:

- Out of airstream** **In the airstream**

OPTIONS:

- BS** Stainless steel bearings.
- MLS-300** Position indicator switch pack.
- MLS-400** Electric Fire Sensor (Re-openable control system). Includes dual heat sensors (165°F and 250°F or 350°F) and position indicator switch pack.
- UFM Factory mounted upper retaining angles.**
- LNM Lower retaining angles by Nailor.** (Shipped loose for field attachment).
- Lower retaining angles by Nailor.** (Shipped loose for field attachment).
- Special Features.** Specify: _____

For installation instructions, see IOM-TCFSDINST (Tunnel Corridor damper) or IOM-1220INST (Combination Fire/Smoke damper).

For supplementary installation instructions for Single-Side Retaining Angles see IOM-FDSSRAINST.

SCHEDULE TYPE:

PROJECT:

ENGINEER:

CONTRACTOR:

Page 1 of 2
 Dimensions are in inches (mm).

DATE	B SERIES	SUPERSEDES	DRAWING NO.
6 - 16 - 16	1220C	5 - 7 - 12	1220C-3

MODEL 1221C-3 APPLICATIONS:

TUNNEL CORRIDOR DAMPER WITH STEEL GRILLE/DIFFUSER:

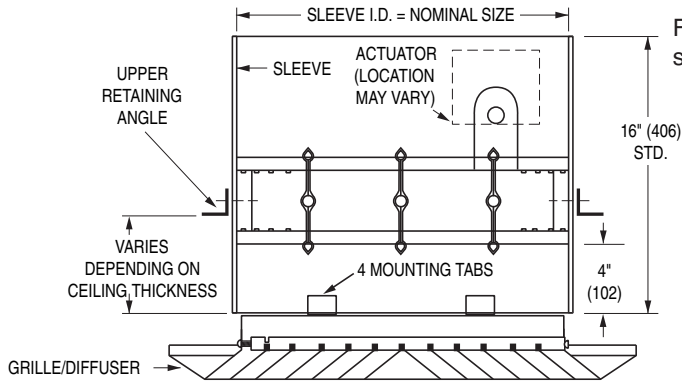

For installation instructions see IOM-TCFSDINST.

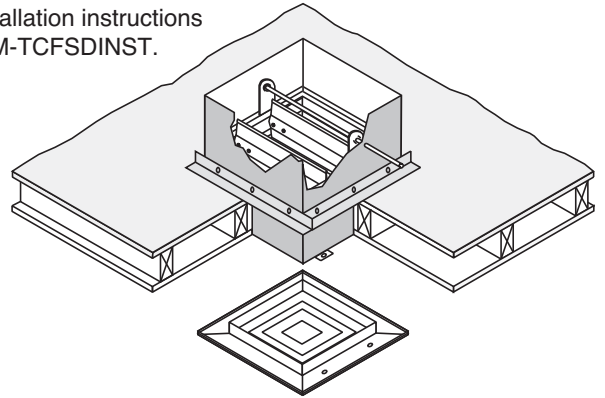

TUNNEL CORRIDOR DAMPER FOR DUCTED INSTALLATIONS:

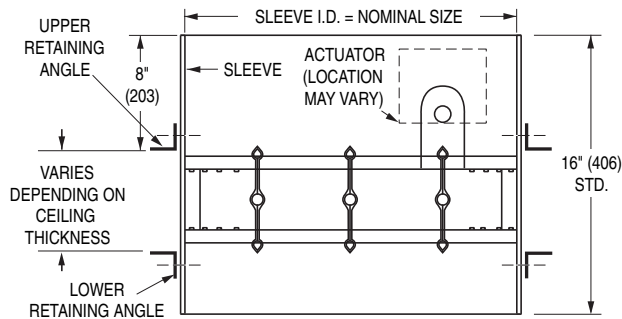

For installation instructions see IOM-TCFSDINST.

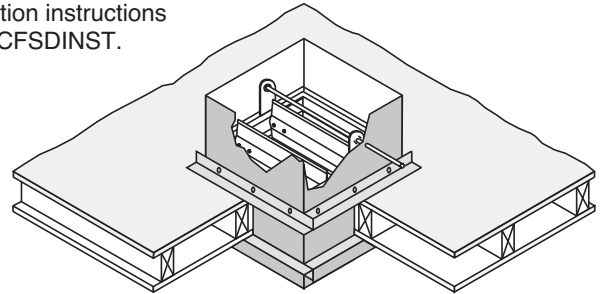

COMBINATION FIRE/SMOKE DAMPER FOR WALLS AND FLOORS:

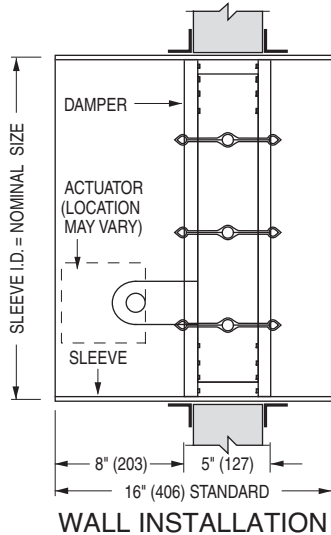

For installation instructions see IOM-1220INST.

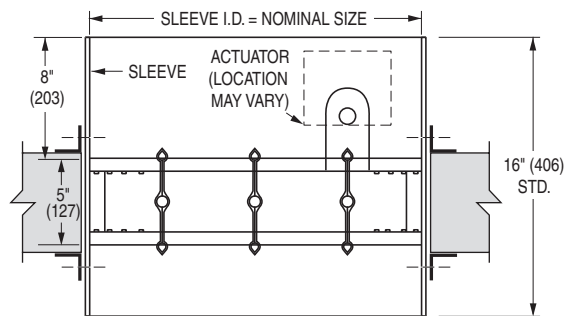

SCHEDULE TYPE:

PROJECT:

ENGINEER:

CONTRACTOR:

Page 2 of 2
Dimensions are in inches (mm).

DATE	B SERIES	SUPERSEDES	DRAWING NO.
6 - 16 - 16	1220C	5 - 7 - 12	1220C-3



TUNNEL CORRIDOR COMBINATION FIRE/SMOKE DAMPER WITH STEEL GRILLE/DIFFUSER
 GRILLE SIDE ACTUATOR ACCESS • 1 HR. LABEL
 AIRFOIL BLADE
 MODEL: 1221C-4

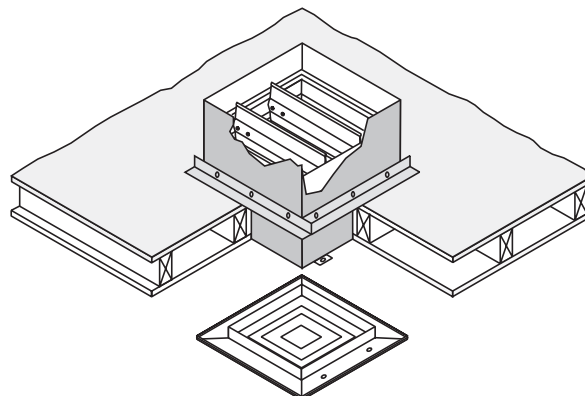
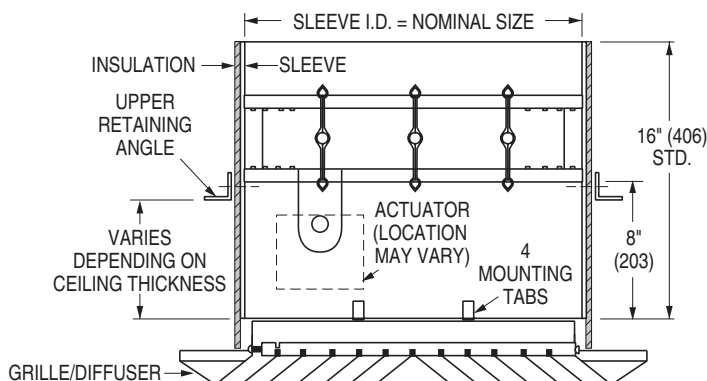

QUALIFICATIONS:

- **UL 555 CLASSIFIED CORRIDOR DAMPER, 1 hr. Fire Resistance Rating (File # R9492).**
- **UL 555S CLASSIFIED SMOKE DAMPER, Class I at 250°F or 350°F elevated temperature (File # R9492).**
- **California State Fire Marshal Listing No. 3225-0935:106.**
- **Meets the requirements of NFPA 90A, NFPA 92A for Fire/Smoke Dampers**
- **Meets the requirements of City of Los Angeles, Uniform Building Code.**
- **Maximum velocity: 2000 fpm @ 4" w.g.**

STANDARD SPECIFICATION:

Frame: 5" x 7/8" x 16 ga. (127 x 22 x 1.6) galvanized steel hat channel.

Blades: 14 ga. (2.0) equivalent galvanized steel formed airfoil on 5 1/2" (140) centers. Opposed action.

Sleeve: **Damper 16" (406) tall and under:** 20" x 20 ga. (506 x 1.0) galvanized steel with 3/4" (19) flange on one end.
Damper over 16" (406) tall: 16" x 20 ga. (406 x 1.0) galvanized steel with 3/4" (19) flange on one end.

Insulation: Intumescent thermal insulation on four sides.

Upper Retaining Angles: 1 1/2" x 1 1/2" x 16 ga. (38 x 38 x 1.6) galvanized steel (by Nailor).

Linkage: Concealed in frame.

Bearings: 1/2" (13) dia. self-lubricating oilite bronze.

Axles: 1/2" (13) dia. plated steel double bolted to blades.

Jamb Seals: Cambered stainless steel.

Heat Responsive Device (Controlled Closure):
 ERL (Electric Resettable Link) is std. on dampers with electric actuators: 250°F (121°C) standard. 165°F (74°C), 212°F (100°C) and 350°F (176°C) available.
 PRL (Pneumatic Replaceable Link) is standard on dampers with pneumatic actuators: 212°F (100°C) standard. 165°F (74°C) and 280°F (138°C) available.

Compatible Steel Supply or Return Air Grille/Diffuser
 (various models available).

Sizes (Duct W x H):

Minimum	Maximum
8" x 8" (203 x 203)	24" x 24" (610 x 610)

BASE MODEL SELECTION:

- 1221C-4** Standard factory sleeve (caulked to UL req.) 16" long x 20 ga. (406 x 1.0).
- 1221C-4** Non-standard sleeve. Specify _____ length _____ ga. Available up to 36" (914) dependent upon wall thickness and 10 through 20 ga. (3.5 through 1.0).

LEAKAGE CLASS / ELEVATED TEMPERATURE:

- I @ 250°F** (Standard)
- I @ 350°F** (Optional)

ACTUATOR SELECTION:

- Electric** **Pneumatic**

Actuators are mounted for Fail Closed (Normally Closed) operation in accordance with code requirements.

ACTUATOR LOCATION:

- In the airstream

OPTIONS:

- BS** Stainless steel bearings.
- MLS-300** Position indicator switch pack.
- DTO** Electric Fire Sensor (Re-openable control system). Includes dual heat sensors (165°F and 250°F or 350°F) and position indicator switch pack.

- UFM Factory mounted upper retaining angles.**

Specify overall ceiling thickness: _____ inches (mm).

- SRT Square-to-Round Transition Collar.**

(top of damper) Dia. = _____ .

GRILLE/DIFFUSER SELECTION:

- Compatible Steel Supply or Return Grille/Diffuser by Nailor. (see attached submittal dwg. for model selection).
- Grille/Diffuser by others.

SCHEDULE TYPE:

PROJECT:

ENGINEER:

CONTRACTOR:

For installation instructions, see IOM-TCOWFSINST.
 Dimensions are in inches (mm).

DATE	B SERIES	SUPERSEDES	DRAWING NO.
10 - 13 - 21	1220C	NEW	1221C-4

The DTS (Damper Test Switch) is an optional "momentary" push button test switch available on all Nailor smoke and combination fire/smoke dampers. The DTS provides the ability to "cycle test" the damper by pushing and holding down the button until the damper has cycled and closure has been visually verified, either by inspecting the damper through the access door or by confirmation at a remote control panel when equipped with the optional MLS-300 position indicator.

The DTS is mounted right on the damper and enables a single maintenance person to test and cycle the damper, eliminating the need for help from another person in the control room.

When a combination fire/smoke damper is ordered, the DTS is combined with the ERL (Electric Resettable Link), in a common enclosure.

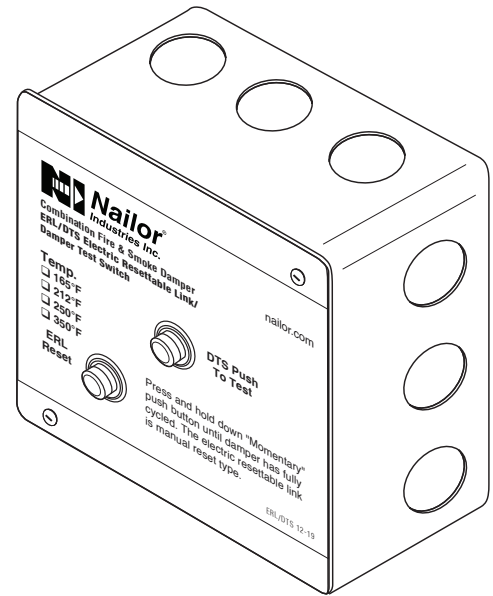

WIRING DIAGRAMS:

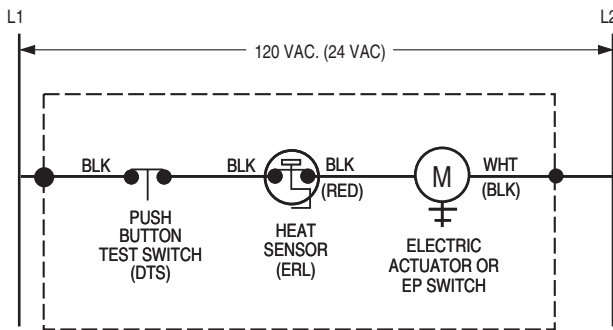

MOUNTED ON DAMPER (FACTORY WIRING TERMINATES AT SPLICE POINTS INDICATED INSIDE 4" x 4" ELECTRICAL BOX)

Figure 1. DTS/ERL Damper Test Switch with Electric Resettable Link

Belimo Actuator Aux. Switch Wiring Connections

Model Series	Open (OP)	Closed (CL)
FSTF	Orange / Gray	Violet / Red
FSLF / FSAFA	Gray / Gray	Violet / Violet
FSNF / FSAFB	White S4 / S6	White S1 / S2

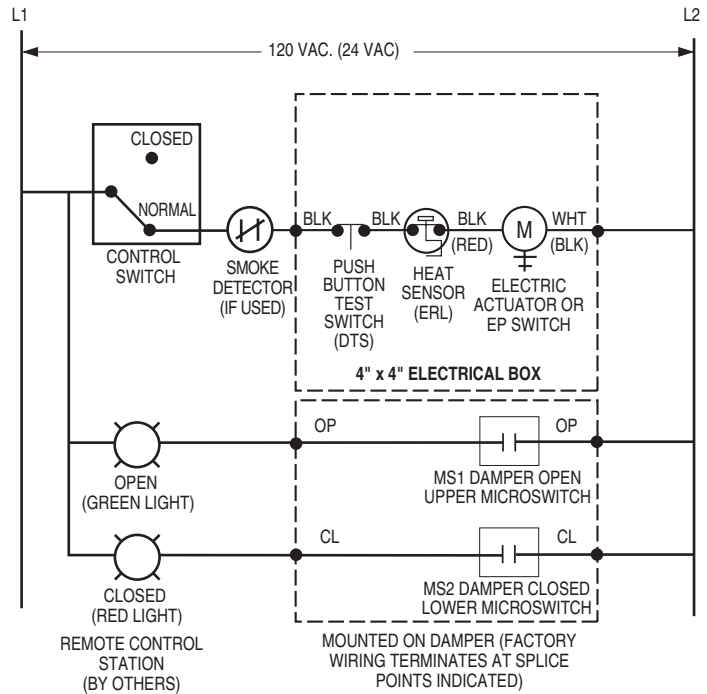

Figure 2. DTS/ERL with MLS-300 Belimo (actuator aux. switches) Position Indicator Package

SCHEDULE TYPE

PROJECT

ENGINEER

CONTRACTOR

DATE

B SERIES

SUPERSEDES

DRAWING NO.

9 - 3 - 20

FD-ACC

3 - 29 - 18

DTS

WIRING DIAGRAMS:

Honeywell Actuator Aux. Switch Wiring Connections

Model Series	Open (OP)	Closed (CL)
MSXX04	Yellow / Yellow	Blue / Blue
MSXX20	Yellow / Yellow	Blue / Blue

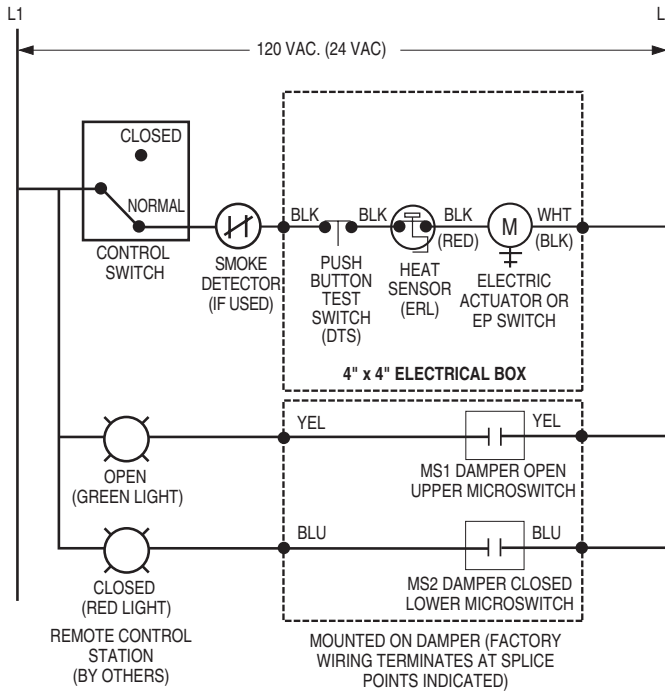

Figure 3. DTS/ERL with MLS-300 Nailor or Honeywell (actuator aux. switches) Position Indicator Package

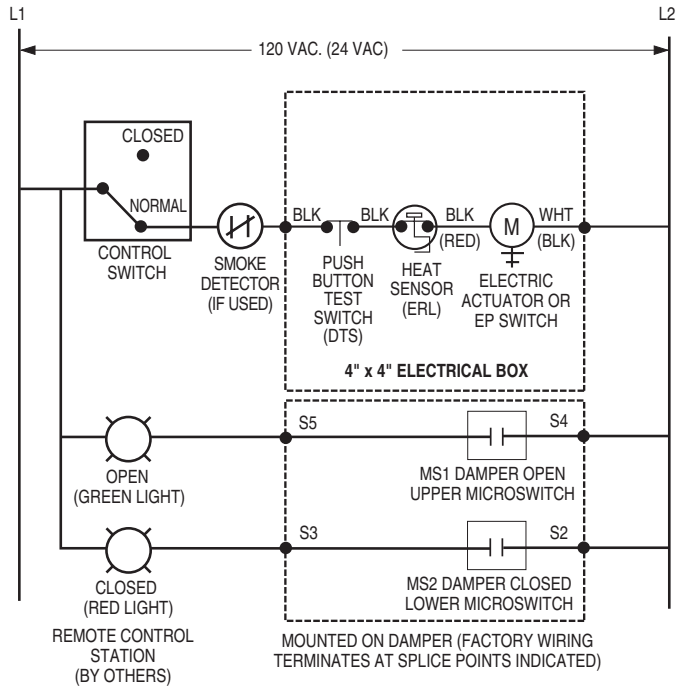
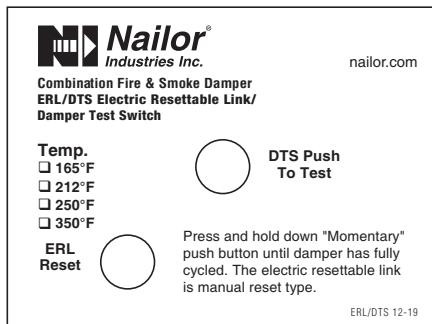
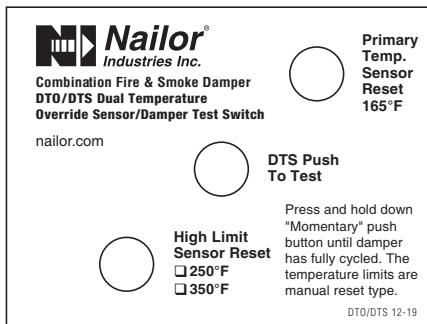

Figure 4. DTS/ERL with MLS-300 Siemens GJD Series (actuator auxiliary switches) Position Indicator Package

DTS LABEL VARIATIONS:



ERL/DTS Combination Fire/Smoke Damper



DTO/DTS Combination Fire/Smoke Damper

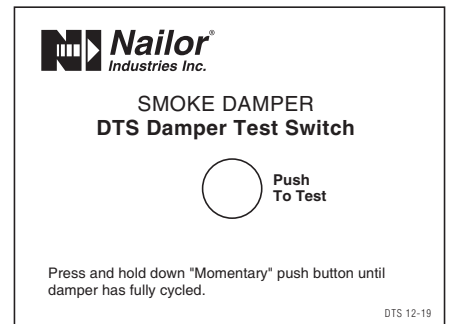

DTS Smoke Damper

SCHEDULE TYPE

PROJECT

ENGINEER

CONTRACTOR

PERFORMANCE DATA:

MODELS: 1221C-1 AND 1221C-2 - 1 HOUR LABEL

MODEL: 1221C-3 - 1 HOUR AND 1 1/2 HOUR LABEL

LEAKAGE CLASS:

The Model 1221C-1 and Model 1221C-2 Series Corridor Dampers have been designed and qualified under UL 555 and UL 555S in order to provide maximum system design flexibility. They are available with a Class I (currently the lowest available) leakage rating with all damper/actuator assemblies having been tested successfully at an elevated temperature of 250°F (121°C) or 350°F (177°C), dependent on actuator, under airflow of 2000 fpm at 4" w.g. (10 m/s @ 1 kPa).

The Model 1221C-3 Series Corridor Combination Fire/Smoke Damper has been designed and qualified under UL 555 and UL 555S in order to provide maximum system design flexibility. It is available with a Class I (currently the lowest available) leakage rating with all damper/actuator assemblies having been tested successfully at an elevated temperature of 250°F (121°C) or 350°F (177°C), dependent on actuator, under airflow of 2000 fpm at 4" w.g. (10 m/s @ 1 kPa).

Models 1221C-1 and 1221C-2 Maximum Performance Ratings	
UL 555 Corridor Damper Fire Rating	1 Hour
UL 555S Leakage Rating	Class I
Maximum Velocity	2000 fpm (10 m/s)
Maximum Pressure	4 in. w.g. (1 kPa)
Maximum Temperature	350°F (177°C)

Model 1221C-3 Maximum Performance Ratings	
UL 555 Corridor Damper Fire Rating	1 Hour
UL 555 Fire Damper Fire Rating	1 1/2 Hour
UL 555S Leakage Rating	Class I
Maximum Velocity	2000 fpm (10 m/s)
Maximum Pressure	4 in. w.g. (1 kPa)
Maximum Temperature	350°F (177°C)

PRESSURE DROP:

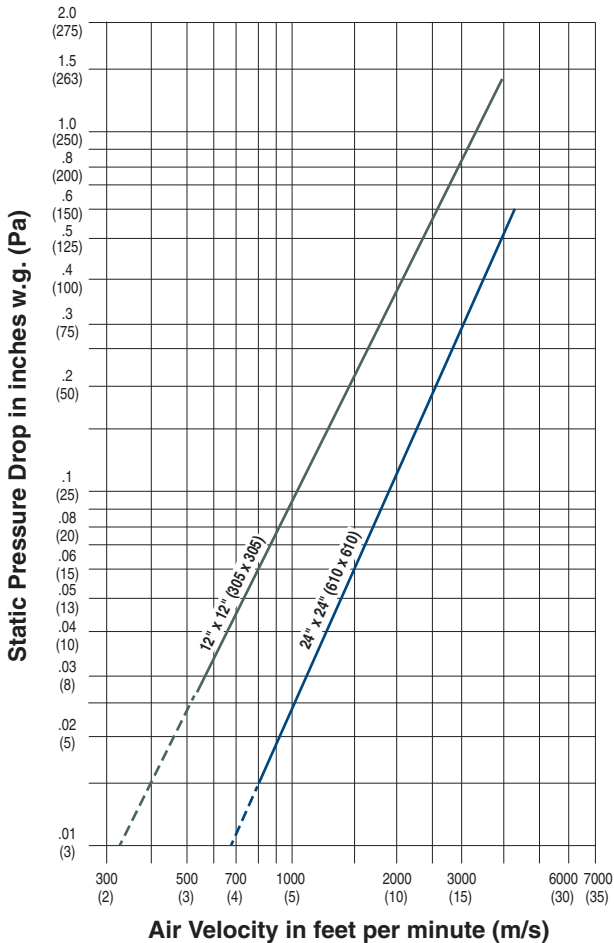

Pressure drop tested per AMCA Standard 500-D, Figure 5.3.
Data corrected to standard air density of 0.075 lbs/ft.³.

COMBINATION FIRE/SMOKE DAMPERS



The DTO Dual Temperature Override Sensor (formerly MLS-400) is a factory installed option on Nailor combination fire/smoke dampers, incorporating two electric heat sensors. A primary heat sensor (manual reset) automatically closes the damper upon sensing an elevated temperature of 165°F (74°C) at the damper. The sensor interrupts power to the actuator, and the actuator's spring return mechanism causes the damper to close. The damper may be closed at anytime by placing a control switch (by others) in the closed position.

The primary heat sensor and the smoke detector (if used) can be bypassed by an external electrical signal from a remote control station, allowing the damper to reopen as may be required in the operation of a smoke control system. The Fire Fighter's Smoke-Control Station must include a three position (double throw, center off) master switch for correct operation.

The damper remains operational until the the temperature at the damper reaches that of the high limit secondary heat sensor. This is the UL listed elevated/degradation temperature rating (operational limit) of the damper/actuator assembly. The standard high limit temperature is 250°F (121°C). A 350°F (177°C) elevated temperature classification is available as an option. When the temperature of the high limit heat sensor is exceeded, the damper closes and locks and remains closed thereafter, in conformance with UL 555 and NFPA 90A. The primary and secondary sensor can be manually reset at the damper using external reset buttons, after temperatures have cooled down.

The DTO can be ordered with electric (120, 24 or 230 VAC) or pneumatic actuators. Pneumatic actuators are supplied with a factory mounted EP (electric/pneumatic) switch.

The DTO Fire Sensor also incorporates a position indicator package. Two auxiliary switches indicate the open and closed damper position at a remote control station.

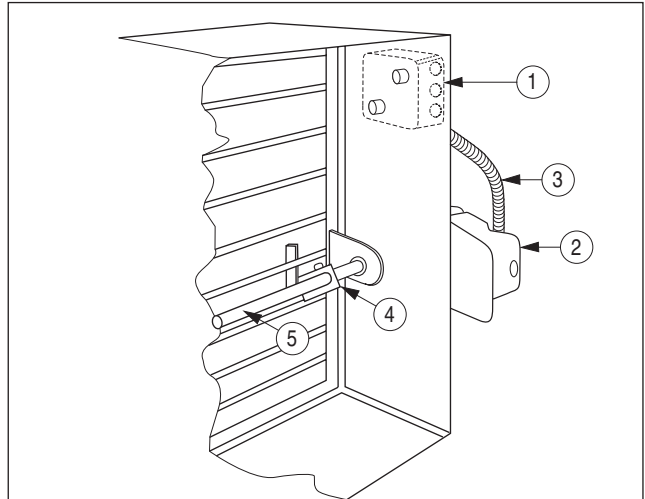

With UL Listed Electric Actuator

Description:

1. Electrical Junction Box with 165°F (74°C) primary heat sensor and High limit secondary heat sensor 250° or 350°F (121° or 177°C)
2. Electric Actuator with auxiliary position indicator switches
3. Flexible Conduit
4. Over-Center Knee Lock
5. Jackshaft

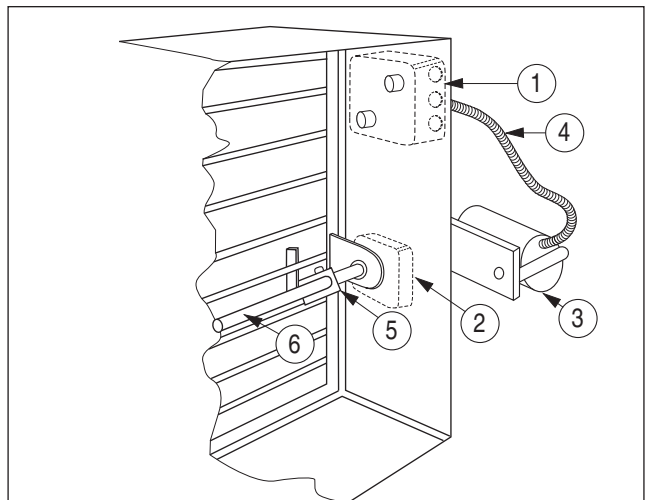

With UL Listed Pneumatic Actuator

Description:

1. Electrical Junction Box with 165°F (74°C) primary heat sensor and EP switch and High limit secondary heat sensor 250° or 350°F (121° or 177°C)
2. Position Indicator Package
3. Pneumatic Actuator
4. Silicone Tubing
5. Over-Center Knee Lock
6. Jackshaft

INSTALLATION:

Pneumatic Connection:

Connect the #1 air inlet port of the electric pneumatic (EP) switch mounted on the electric junction box to the pneumatic main air supply (1/8" [3] NPT barbed fitting). Metallic tubing requires a silicone tubing pigtail and compression fitting (by others). Rated operating main air pressure is 25 psi.

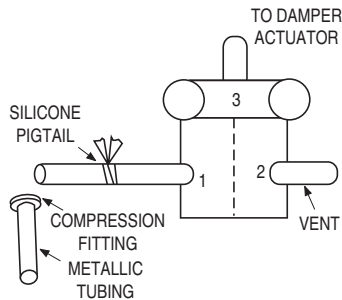

Electrical Connections for Pneumatic or Electrical Actuators

1. Remove cover of junction box. There are seven coded color wires. Consult applicable wiring diagram, see Figures 1, 2 and 3. Color coding of position indicator microswitches (Aux. switches) varies dependent upon actuator.

MS1 is damper open signal.

MS2 is damper closed signal.

Important: Installer must double check continuity of **MS1** and **MS2** before wiring to confirm which switch signals the damper's open or closed position.

2. Connect external wiring from the remote control panel and electrical power supply (120, 24 or 230 VAC) in accordance with N.E.C. and any applicable local codes.
3. It is essential that the remote controls include a 3-position master control switch (single pole double throw, center off) and that it is connected to operate as shown.
4. Replace junction box cover and check operation.

OPERATION:

Circuit Test

Combination fire/smoke dampers with the DTO Dual Temperature Override Sensor option are supplied with factory mounted spring return actuators that have a power open/fail closed (normally closed) damper connection.

1. Place master control switch (MCS) in center closed position.
2. Apply power. The damper will remain closed and the closed (red) indicator light will go on.
3. Place MCS in reopen (override) position. The damper will open. The closed (red) indicator light will go off and the open (green) indicator light will go on. Note: When the MCS is in the reopen (override) position, the smoke detector (if used) and primary heat sensor are bypassed. The damper will remain open even if the primary heat sensor has been activated. Do not leave MCS in reopen position.
4. Place MCS in the normal (auto) position. The damper will remain open and the open (green) indicator light will remain on.

Emergency Operation (Smoke Control Management)

1. MCS Normal Position

- (a) **Fire Control:** The damper is open and will remain so until the primary heat sensor activates when temperatures at the damper reach 165°F (74°C), when the damper will close. The primary heat sensor is a manual reset device and the damper will remain closed until the override signal for smoke management from a remote command station is present and the duct temperature has not exceeded the high limit. If temperatures reach the elevated temperature rating of the damper/actuator assembly (250°F or 350°F [121° or 177°C]), the high limit secondary heat sensor will either prevent the damper from reopening or will close and lock the damper, rendering it inoperable from a remote location. A manual reset button is provided on the DTO that may be used to reopen damper upon cessation of fire conditions.
- (b) **Smoke Control (Optional):** If a smoke detector (wired with normally closed contacts) is included in the design, when activated, power to the actuator is interrupted and the damper will close.

2. MCS Closed Position

The damper will close regardless of whether the primary heat sensor or smoke detector has activated or not.

3. MCS Reopen Position

If the damper has not been exposed to an elevated temperature higher than its rating (250°F or 350°F [121°C or 177°C]), the damper will open, bypassing the primary heat sensor and smoke detector regardless of whether they have been activated or not. This provides control of the smoke management system and is to be done only by an authorized party per NFPA 92, Smoke Control Systems. If the damper has been exposed to an elevated temperature higher than its temperature degradation rating (250°F or 350°F [121°C or 177°C]), the damper will close and remain closed under all conditions (regardless of any MCS position) in accordance with NFPA 90A.

Testing

Damper system testing may be done by:

1. Remotely using the master control switch (MCS) to cycle the damper.
2. Activating the smoke detector.
3. Periodic Inspection, Testing and Maintenance.

Refer to IOM-FSDIMP Operation and Maintenance procedure.

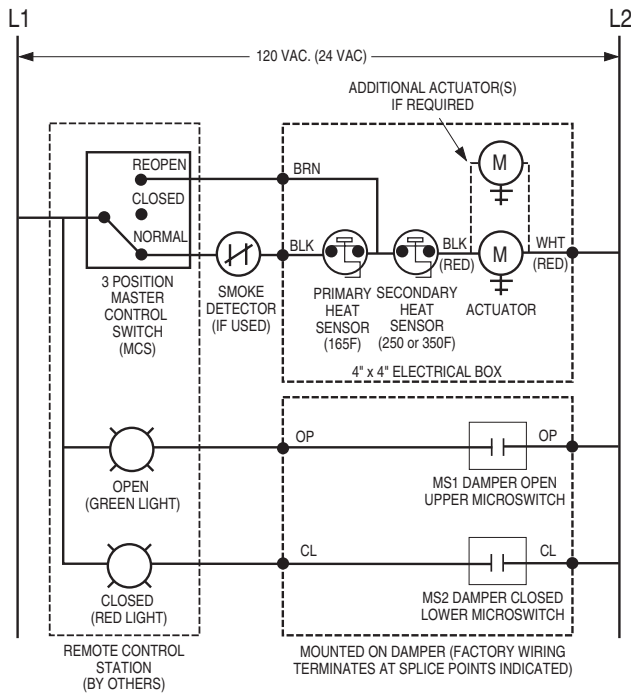

POSITION INDICATOR MICROSWITCH RATINGS: SINGLE POLE DOUBLE THROW (2), AT OR BELOW 240 VAC; RESISTIVE LOAD: 8A, INDUCTIVE LOAD: 2A, AT 125 VDC; 0.5A, PILOT DUTY: 4A, 125 VAC.

Fig. 1. DTO with Belimo Electric Actuators with built-in Auxiliary Switches.

Belimo Actuator Auxiliary Switch Wiring Connections

Model Series	Open (OP)	Closed (CL)
FSTF	Orange / Gray	Violet / Red
FSLF / FSAF	Gray / Gray	Violet / Violet
FSNF / FSAFB	White S4 / S6	White S1 / S2

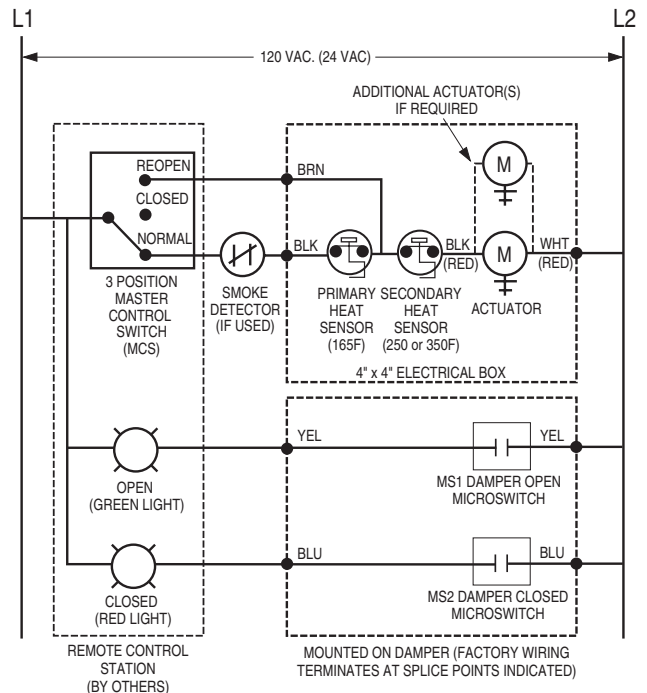

POSITION INDICATOR MICROSWITCH RATINGS: SINGLE POLE SINGLE THROW (2), MAX. LOAD: 250VAC, 5A RESISTIVE, 4A INDUCTIVE.

Fig. 2. DTO with Honeywell Electric Actuators with built-in Auxiliary Switches.

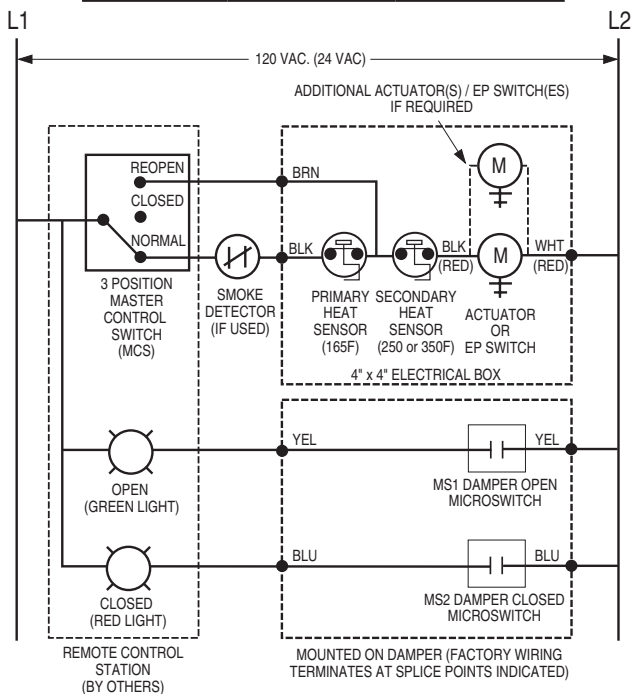

POSITION INDICATOR MICROSWITCH RATINGS: SINGLE POLE DOUBLE THROW (2), 15A, 125, 250 VAC OR 24 VDC, 0.5A, 125 Vdc, 0.25A, 250Vdc.

Fig. 3. DTO with Electric (Belimo, Honeywell, Siemens) or 331-2961/3060 (pneumatic) actuators and Nailor position indicator package.

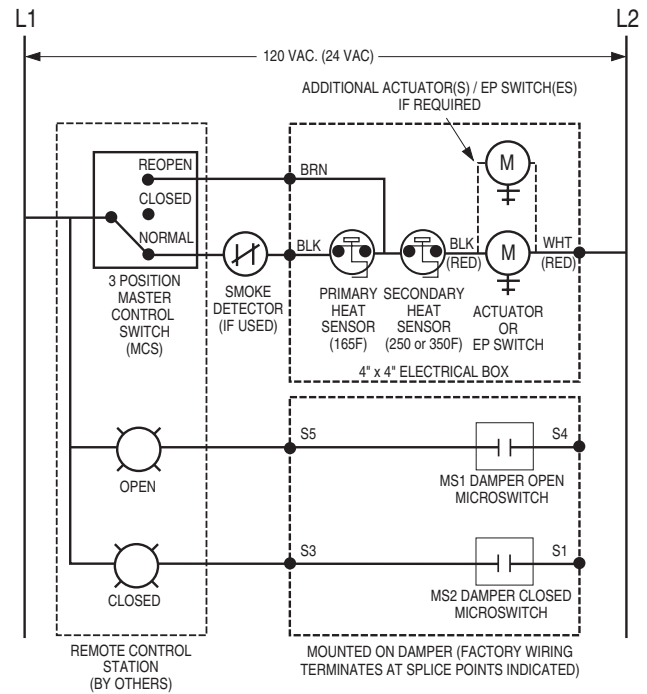

POSITION INDICATOR MICROSWITCH RATINGS: SINGLE POLE DOUBLE THROW (2), 15A, 125, 250 VAC OR 24 VDC, 0.5A, 125 Vdc, 0.25A, 250Vdc.

Fig. 4. DTO with Siemens GJD Series Electric actuators with built-in Auxiliary Switches.



Houston, Texas
Tel: 281-590-1172
Fax: 281-590-3086

Las Vegas, Nevada
Tel: 702-648-5400
Fax: 702-638-0400

Toronto, Canada
Tel: 416-744-3300
Fax: 416-744-3360

Calgary, Canada
Tel: 403-279-8619
Fax: 403-279-5035

The current edition of NFPA 92, *Standard for Smoke Control Systems*, classifies all systems used to address the impact of smoke from a fire as a Smoke Control System. Smoke control systems are categorized in two ways: as Smoke Containment Systems, the sub-classification of pressurization systems, and Smoke Management Systems, the sub-classification of systems for large-volume spaces. These systems can be further classified as either a Dedicated Smoke Control System (installed for the sole purpose of providing smoke control) or a Non-dedicated Smoke Control System (shares components with another system [i.e. the building HVAC system] and changes the mode of operation to achieve smoke control).

Per NFPA 105, *Standard for Smoke Door Assemblies and Other Opening Protectives*, periodic inspecting and testing and maintenance of Smoke Dampers shall also be in accordance with NFPA 92 and Combination Fire/Smoke Dampers shall meet the testing requirements prescribed in NFPA 80, *Standard for Fire Doors and Other Opening Protectives*. Consult your local building code to verify whether there is a required maintenance and testing schedule. Most local jurisdictions reference NFPA 105 for smoke dampers and NFPA 80 for combination fire/smoke dampers.

Periodic Inspection, Testing and Maintenance

Per NFPA 92, Dedicated Smoke Control Systems shall be tested at least semiannually and Nondedicated Smoke Control Systems shall be tested at least annually and dampers that are a part of these systems shall be cycled as part of this testing. Per NFPA 80, fire dampers (which includes Combination Fire/Smoke Dampers) shall be inspected 1 year after installation and then every 4 years, except for hospitals where the frequency is every 6 years. In addition to these requirements, NFPA 72, *National Fire Alarm and Signaling Code*, outlines periodic testing requirements for various types of fire alarm systems and components associated with these systems (i.e. Duct Smoke Detectors).

All requirements of testing for actuated smoke and fire/smoke dampers are to be conducted under normal HVAC airflow conditions.

1. Remove any obstructions, dirt, rust, corrosion, or other observed conditions that could impede proper damper operation. Clean damper blades and other moving parts if necessary. Use of a mild detergent or solvents is recommended for any cleaning required.
2. Linkage and jackshaft bearing brackets should be lubricated with a dry lubricant (such as T.F.E. Dry Lube). Never use a regular lubricating oil on dampers, as it will attract dirt and grit. Blade linkage is concealed in the side jamb out of the airstream and is maintenance free. Bearings are self-lubricating oilite bronze.
3. Verify that appropriate power (voltage or pneumatic air pressure) is being supplied to the actuator. Check actuator and tighten the linkage or coupling as necessary. Refer to manufacturer's recommended maintenance procedure for pneumatic and electric actuators.
4. All inspections and testing shall be documented indicating the location of the damper, date of inspection, name of inspector, deficiencies detected, and how deficiencies were corrected.
5. Remote Testing: According to the most recent versions of NFPA 80 and NFPA 105, Actuated Smoke and Combination Fire/Smoke Dampers only need to be visually tested at the initial testing during commissioning. This inspection will confirm that the position indication method accurately reflects the full-open and full-closed position of the damper. From this point, all following inspections can be done remotely with the use of the position indicator switches.

Dampers with Position Indicating Device

1. Use the signal from the damper's position indication device to determine if the damper is in the fully open position.
2. Remove air pressure or electrical power from the actuator to cause the actuator's spring return feature to close the damper.
3. Use the signal from the damper's position indication device to determine if the damper is in the fully closed position.
4. Reapply air pressure or electrical power to reopen the damper.
5. Use the signal from the damper's position indication device to determine if the damper is in the fully open position.

Dampers without Position Indicating Device

1. Visually confirm that the damper is in the fully open position.
2. Ensure that all obstructions are out of the path of the damper blades and then remove air pressure or electrical power from the actuator to cause the actuator to spring to the fully closed position.
3. Visually confirm that the damper is in the fully closed position.
4. Reapply air pressure or electrical power to reopen the damper.

Care should be exercised to ensure that all tests are performed safely by personnel wearing the appropriate personal protective equipment and such tests do not cause system damage. All inspections and testing shall be documented indicating the location of the damper, date of inspection, name of inspector, deficiencies detected, and how deficiencies were corrected.

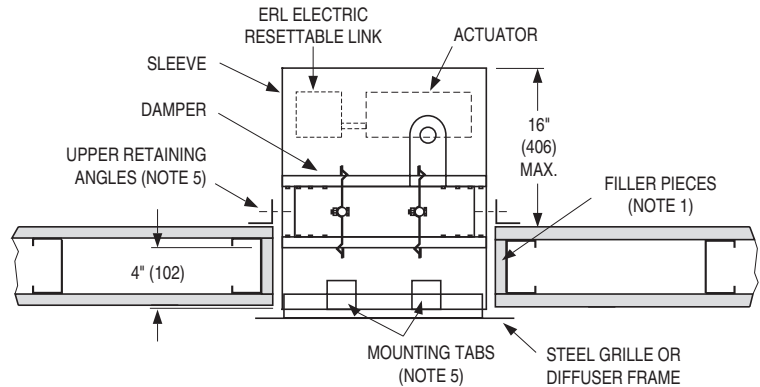
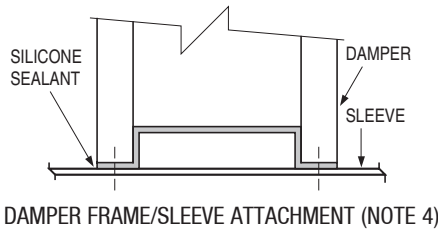

MOUNTING TABS ARE BENT AFTER INSTALLING THROUGH OPENING.

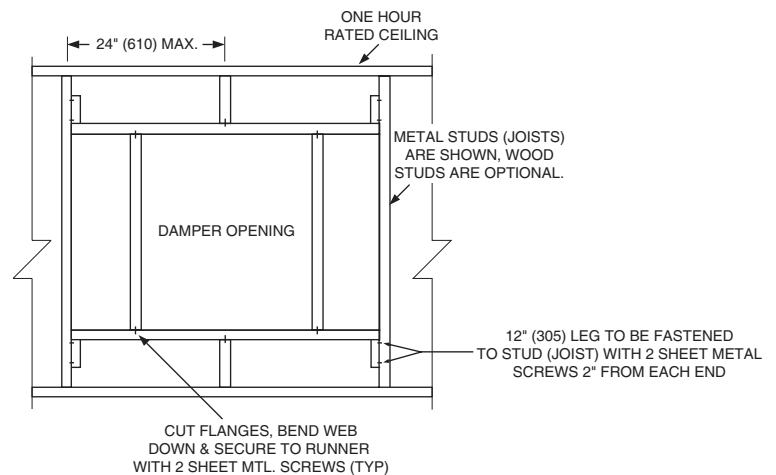
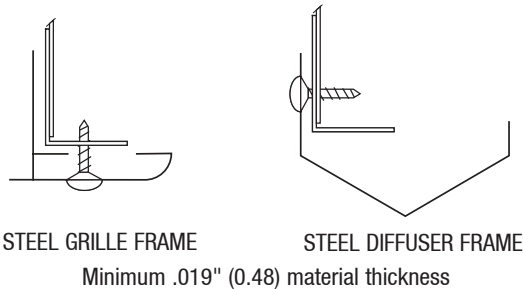

CEILING FRAMING DETAIL

QUALIFICATIONS:

- Meets all the requirements of UL 555 and UL 555S.
- Meets the requirements for NFPA 90A, NFPA 92A
- Meets the requirements of City of Los Angeles, Uniform Building Code.
- California State Fire Marshal Listing No. 3225-0935:106.

CEILING FRAMING NOTES:

1. If wood studs are used, fasten filler pieces on 12" (305) max. centers in opening. If metal studs are used, filler pieces are optional.
2. The thickness of the gypsum board and the size of the drywall studs are dictated by the fire-rated ceiling design.

NOTES:

1. Installation shall be in accordance with the appropriate requirements of the National Fire Protection Association Standard NFPA 90A latest edition.
2. **Damper Sleeve:** Sleeve thickness must be equal to or thicker than the duct connected to it. Sleeve gauge requirements are listed in the SMACNA Fire, Smoke and Radiation Damper Installation Guide for HVAC Systems and in NFPA 90A. If a break-away style duct/sleeve connection is not used, damper sleeves of not less than 16 gauge (1.61) coated steel may be attached to the duct with screws or other types of mechanical fasteners. The maximum sleeve thickness for such rigid joints is 10 gauge (3.51) for coated steel.
 The connecting duct shall not be continuous thru the wall or floor opening but shall terminate at the sleeve. Sleeves shall extend a maximum of 16" (406) on the side intended for use with an actuator.
3. **Break-away duct/sleeve connections:**
 - a. Rectangular ducts must use one or more of the following connections if the gauge is less than the requirement in Note 2 for rigid connections:
 In addition:

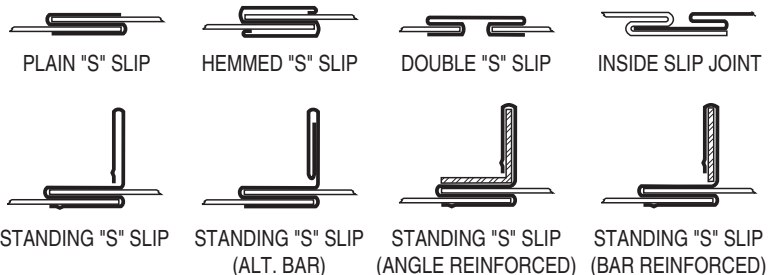

Dimensions are in inches (mm).

- A maximum of two #10 sheet metal screws on each side and on the bottom, located in the center of the slip pocket and penetrating both sides of the slip pocket may be used.
- One of the above connections on the top and bottom joints with flat drive slip connections on the side joints may be used for dampers up to 20" (508) in height.



FLAT DRIVE SLIP

b. Round or oval duct may be attached to the round or oval collar which is part of the damper/sleeve in the following manner:

- Duct diameters 22" (559) and smaller must use three #10 sheet metal screws equally spaced around the circumference.

Note: When optional sealing of these break-away connections is desired, the duct sealant shall be PA2084T Duct Sealant Adhesive as manufactured by Precision or water based DP1010 by Design Polymetrics.

c. For the use of approved alternative Ductmate or TDC/TDF break-away connections, refer to the supplements noted on this page.

4 Damper/sleeve attachment: Damper shall be secured to sleeve with 1/4" (6) long welds, 3/16" (4.76) steel rivets, 1/4" (6.35) dia. bolts and nuts, #8 sheet metal screws, or 3/16" (4.76) dia. buttonlocks on both sides at 6" (152) on center and a maximum of 4" (102) from the corners of the damper on all four sides. For field assembled sleeves, the inner dimensions of the sleeve shall be equal to the outer dimensions of the damper. All joints between the damper and the sleeve shall be sealed with Dow-Corning 732, G.E.108, Boss 310 or 315 RTV silicone sealant on one side only.

5. Upper Retaining angles shall be a minimum of 1 1/2" x 1 1/2" x 16 gauge (38 x 38 x 1.61). Secure the retaining angles to the sleeve with 1/2" (12.7) long welds, 1/4" (6.35) dia. bolts and nuts, 3/16" (4.76) dia. steel rivets or #8 sheet metal screws 8" (203) on center and 2" (51) maximum from corner of sleeve on all four sides. The retaining angles must lap the structural opening by 1" (25.4) minimum. When the ductwork terminates at the ceiling, 2" (51) wide mounting tabs are fastened to the sleeve in two places on each of two opposite sides of the sleeve. These tabs are bent over after installing damper through ceiling opening. A steel grille or diffuser frame with a minimum 1" (25.4) flange is then fastened to the mounting angle tabs with sheet metal screws.

6. Expansion clearance between the sleeve and wall or floor shall be a minimum of 1/8" per foot (3.18 per 305) of width or height of the sleeve. The maximum size of the opening shall be 1/8" (3.18) larger in either dimension than the allowable minimum size. For example; a sleeve dimension of 24" x 24" (610 x 610) shall have an opening size of 24 1/4" x 24 1/4" (616 x 616) minimum and 24 3/8" x 24 3/8" (619 x 619) maximum.

7. Maximum Damper Size: 24" x 24". Minimum size is 8" x 8" (203 x 203).

8. Actuator Connections and accessories: Combination fire/smoke dampers and qualified actuators are tested together by UL and are factory installed to qualify for damper/actuator standard warranties. Factory installed electric actuators are either 24,120 or 230 VAC. All wiring must be in accordance with the appropriate electrical codes and NFPA 70. Factory installed pneumatic actuators are rated at and have a maximum pressure of 25 PSI. The pneumatic actuator shall be connected to the air supply thru metallic tubing. A short silicone tubing pigtail is acceptable.

ERL (Electric Resettable Link): Dampers are supplied with an electric thermostat-type temperature responsive device as standard. Refer to Figure 1 for wiring of the ERL. If dampers are ordered with a pneumatic actuator and ERL, an EP switch is required with an appropriate electric power circuit to allow the ERL to control the pneumatic actuator.

When DTO Dual Temperature Override Sensors (MLS-400) or MLS-300 position indicators are used, refer to the installation and wiring instructions for these units. Documents IOM-DTO and IOM-MLS3 (H or N) respectively.

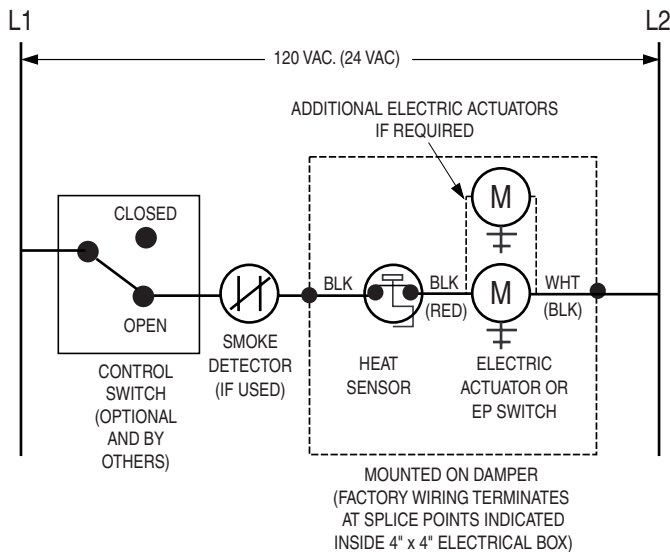

Figure 1. ERL Wiring

IMPORTANT:

- DO NOT CAST DAMPER IN PLACE.
- DO NOT FASTEN RETAINING ANGLES OR DAMPER DIRECTLY TO CEILING.
- DO NOT INSTALL DAMPER OUT OF SQUARE OR OUT OF FLAT.
- DO CYCLE DAMPER AFTER INSTALLATION TO ASSURE PROPER OPERATION.

REFER TO THE APPROPRIATE NAILOR INSTALLATION INSTRUCTION SUPPLEMENTS FOR ADDITIONAL INFORMATION OR SPECIAL REQUIREMENTS:

MLS-300 (Honeywell) POSITION INDICATOR	MLS3H
MLS-300 (Nailor) POSITION INDICATOR	MLS3N
DTO DUAL TEMPERATURE OVERRIDE SENSOR (MLS-400)	DTO
ERL ELECTRIC RESETTABLE LINK	ERL
DUCTMATE BREAKAWAY CONNECTIONS	FDDMINST
TDC/TDF FLANGED DUCT CONNECTION	FDTDCFINST
QUICK-SET RETAINING ANGLES	FDQSRA

Dimensions are in inches (mm).



Houston, Texas
Tel: 281-590-1172
Fax: 281-590-3086

Las Vegas, Nevada
Tel: 702-648-5400
Fax: 702-638-0400

Toronto, Canada
Tel: 416-744-3300
Fax: 416-744-3360

Calgary, Canada
Tel: 403-279-8619
Fax: 403-279-5035

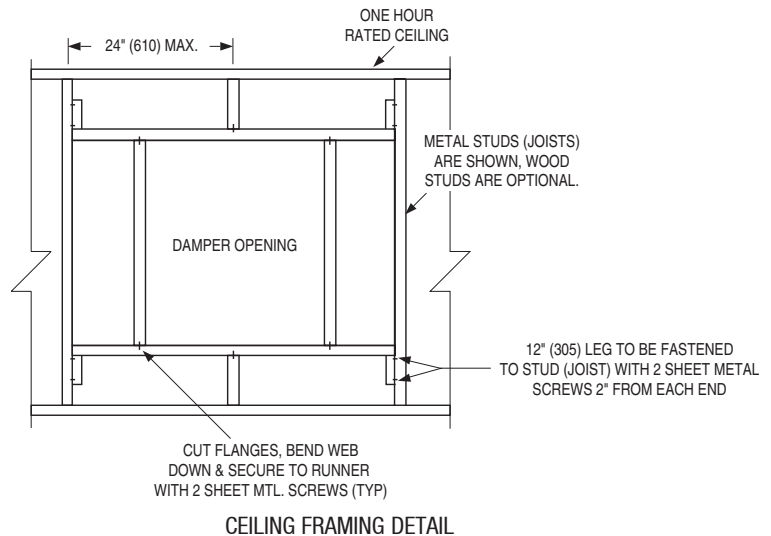
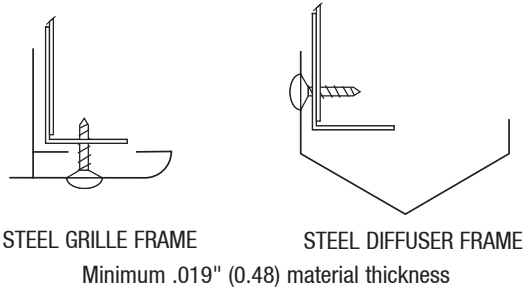
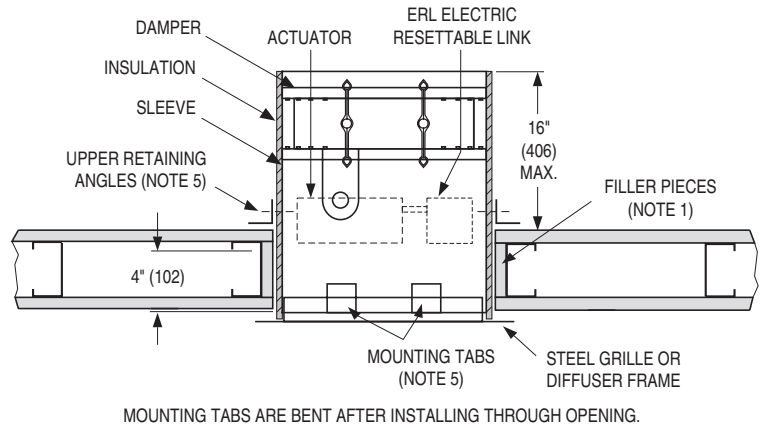
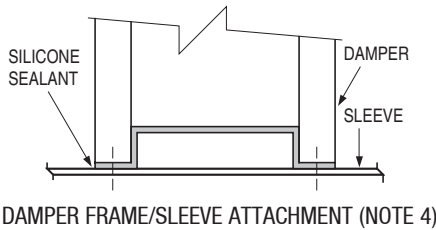

QUALIFICATIONS:

- Meets all the requirements of UL 555 and UL 555S.
- Meets the requirements for NFPA 90A, NFPA 92A
- Meets the requirements of City of Los Angeles, Uniform Building Code.
- California State Fire Marshal Listing No. 3225-0935:106.

CEILING FRAMING NOTES:

1. If wood studs are used, fasten filler pieces on 12" (305) max. centers in opening. If metal studs are used, filler pieces are optional.
2. The thickness of the gypsum board and the size of the drywall studs are dictated by the fire-rated ceiling design.

NOTES:

1. Installation shall be in accordance with the appropriate requirements of the National Fire Protection Association Standard NFPA 90A latest edition.
2. **Damper Sleeve:** Sleeve thickness must be equal to or thicker than the duct connected to it. Sleeve gauge requirements are listed in the SMACNA Fire, Smoke and Radiation Damper Installation Guide for HVAC Systems and in NFPA 90A. If a break-away style duct/sleeve connection is not used, damper sleeves of not less than 16 gauge (1.61) coated steel may be attached to the duct with screws or other types of mechanical fasteners. The maximum sleeve thickness for such rigid joints is 10 gauge (3.51) for coated steel.
 The connecting duct shall not be continuous thru the wall or floor opening but shall terminate at the sleeve. Sleeves shall extend a maximum of 16" (406) on the side intended for use with an actuator.

3. Break-away duct/sleeve connections:

- a. Rectangular ducts must use one or more of the following connections if the gauge is less than the requirement in Note 2 for rigid connections:
 In addition:

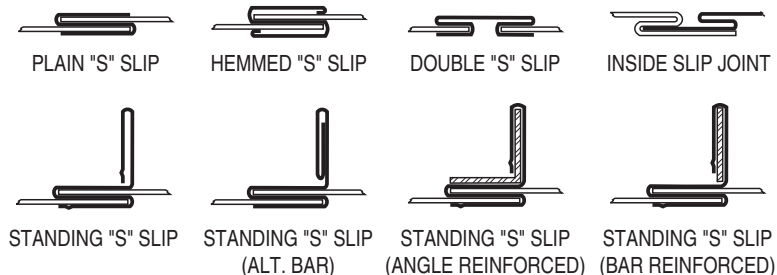

Dimensions are in inches (mm).

- A maximum of two #10 sheet metal screws on each side and on the bottom, located in the center of the slip pocket and penetrating both sides of the slip pocket may be used.
- One of the above connections on the top and bottom joints with flat drive slip connections on the side joints may be used for dampers up to 20" (508) in height.



FLAT DRIVE SLIP

b. Round or oval duct may be attached to the round or oval collar which is part of the damper/sleeve in the following manner:

- Duct diameters 22" (559) and smaller must use three #10 sheet metal screws equally spaced around the circumference.

Note: When optional sealing of these break-away connections is desired, the duct sealant shall be PA2084T Duct Sealant Adhesive as manufactured by Precision or water based DP1010 by Design Polymetrics.

c. For the use of approved alternative Ductmate or TDC/TDF break-away connections, refer to the supplements noted on this page.

4 Damper/sleeve attachment: Damper shall be secured to sleeve with 1/4" (6) long welds, 3/16" (4.76) steel rivets, 1/4" (6.35) dia. bolts and nuts, #8 sheet metal screws, or 3/16" (4.76) dia. buttonlocks on both sides at 6" (152) on center and a maximum of 4" (102) from the corners of the damper on all four sides. For field assembled sleeves, the inner dimensions of the sleeve shall be equal to the outer dimensions of the damper. All joints between the damper and the sleeve shall be sealed with Dow-Corning 732, G.E.108, Boss 310 or 315 RTV silicone sealant on one side only.

5. Upper Retaining angles shall be a minimum of 1 1/2" x 1 1/2" x 16 gauge (38 x 38 x 1.61). Secure the retaining angles to the sleeve with 1/2" (12.7) long welds, 1/4" (6.35) dia. bolts and nuts, 3/16" (4.76) dia. steel rivets or #8 sheet metal screws 8" (203) on center and 2" (51) maximum from corner of sleeve on all four sides. The retaining angles must lap the structural opening by 1" (25.4) minimum. When the ductwork terminates at the ceiling, 2" (51) wide mounting tabs are fastened to the sleeve in two places on each of two opposite sides of the sleeve. These tabs are bent over after installing damper through ceiling opening. A steel grille or diffuser frame with a minimum 1" (25.4) flange is then fastened to the mounting angle tabs with sheet metal screws.

6. Expansion clearance between the sleeve and wall or floor shall be a minimum of 1/8" per foot (3.18 per 305) of width or height of the sleeve. The maximum size of the opening shall be 1/8" (3.18) larger in either dimension than the allowable minimum size. For example; a sleeve dimension of 24" x 24" (610 x 610) shall have an opening size of 24 1/4" x 24 1/4" (616 x 616) minimum and 24 3/8" x 24 3/8" (619 x 619) maximum.

7. Maximum Damper Size: 24" x 24". Minimum size is 8" x 8" (203 x 203).

8. Actuator Connections and accessories: Combination fire/smoke dampers and qualified actuators are tested together by UL and are factory installed to qualify for damper/actuator standard warranties. Factory installed electric actuators are either 24,120 or 230 VAC. All wiring must be in accordance with the appropriate electrical codes and NFPA 70. Factory installed pneumatic actuators are rated at and have a maximum pressure of 25 PSI. The pneumatic actuator shall be connected to the air supply thru metallic tubing. A short silicone tubing pigtail is acceptable.

ERL (Electric Resettable Link): Dampers are supplied with an electric thermostat-type temperature responsive device as standard. Refer to Figure 1 for wiring of the ERL. If dampers are ordered with a pneumatic actuator and ERL, an EP switch is required with an appropriate electric power circuit to allow the ERL to control the pneumatic actuator.

When DTO Dual Temperature Override Sensors (MLS-400) or MLS-300 position indicators are used, refer to the installation and wiring instructions for these units. Documents IOM-DTO and IOM-MLS3 (H or N) respectively.

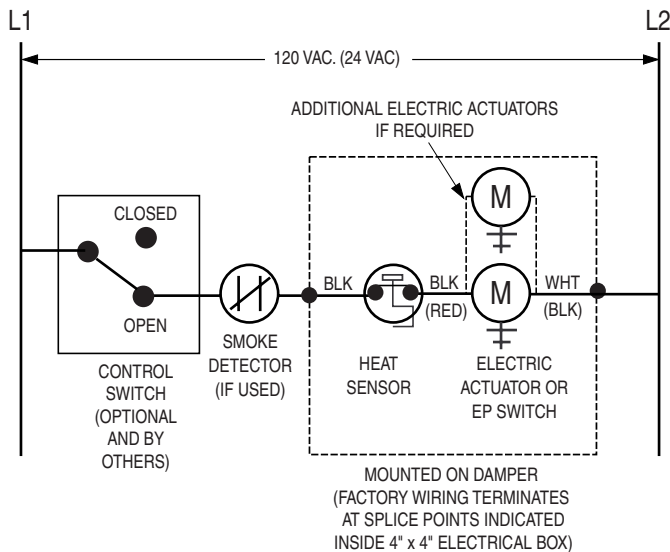

Figure 1. ERL Wiring

IMPORTANT:

- DO NOT CAST DAMPER IN PLACE.
- DO NOT FASTEN RETAINING ANGLES OR DAMPER DIRECTLY TO CEILING.
- DO NOT INSTALL DAMPER OUT OF SQUARE OR OUT OF FLAT.
- DO CYCLE DAMPER AFTER INSTALLATION TO ASSURE PROPER OPERATION.

REFER TO THE APPROPRIATE NAILOR INSTALLATION INSTRUCTION SUPPLEMENTS FOR ADDITIONAL INFORMATION OR SPECIAL REQUIREMENTS:

MLS-300 (Honeywell) POSITION INDICATOR	MLS3H
MLS-300 (Nailor) POSITION INDICATOR	MLS3N
DTO DUAL TEMPERATURE OVERRIDE SENSOR (MLS-400)	DTO
ERL ELECTRIC RESETTABLE LINK	ERL
DUCTMATE BREAKAWAY CONNECTIONS	FDDMINST
TDC/TDF FLANGED DUCT CONNECTION	FDTDCFINST
QUICK-SET RETAINING ANGLES	FDQSRA

Dimensions are in inches (mm).



Houston, Texas
Tel: 281-590-1172
Fax: 281-590-3086

Las Vegas, Nevada
Tel: 702-648-5400
Fax: 702-638-0400

Toronto, Canada
Tel: 416-744-3300
Fax: 416-744-3360

Calgary, Canada
Tel: 403-279-8619
Fax: 403-279-5035