



COMBINATION FIRE/SMOKE DAMPER
VERTICAL AIRFOIL BLADE
1 1/2 HR. LABEL • ULTRA-LOW LEAKAGE
HIGH PERFORMANCE
MODEL: 1221VB (TYPE A WITH SLEEVE)



QUALIFICATIONS:

- **UL 555 & CAN/ULC-S112 CLASSIFIED DYNAMIC FIRE DAMPER** 1 1/2 hr. Label (File #'s R9492 & R19569).
- **UL 555S CLASSIFIED SMOKE DAMPER (File # R9492)** Leakage Class I or II at 250°F elevated temperature.
- **City of New York. MEA #366-03-M.**
- **California State Fire Marshal: Fire Damper Listing No. 3225-0935:106.**
- **Meets NFPA 80, 90A, 92A, 92B, 101 and 105 as well as IBC and NBC (Canada) Building Code requirements.**
- **Maximum velocity: 2000 fpm @ 4" w.g.**

Model 1221VB (Vertical Blade) is a high performance combination fire/smoke damper that provides superior protection and versatility. The vertical blade configuration allows for the actuator to be mounted below the damper and is ideal for applications where bottom access is desired or where there isn't space for a side mounted actuator.

The 1221VB Series dampers are ideal for applications where building codes require both a fire damper for the protection of ductwork penetrations in walls that have a fire resistance rating of up to 2 hours and also require a leakage rated damper for operational smoke control in static or dynamic smoke management systems.

The 1221VB Series has been especially designed and tested to provide premium performance. It offers the lowest leakage class available and is qualified for installation with airflow in either direction. Airfoil blade design and elimination of blade sills provide a low pressure drop design.

Unique, inter-locking double skin blade design provides flame and smoke seal under fire conditions at temperatures up to 2000°F.

STANDARD SPECIFICATION:

- Frame:** 5" x 7/8" x 16 ga. (127 x 22 x 1.6) galvanized steel hat channel.
Blades: 14 ga. (2.0) equivalent galvanized steel formed airfoil on 5 1/2" (140) centers. Opposed action.
Linkage: Concealed in frame. 12 ga. (2.7) plated steel.
Bearings: 1/2" (13) dia. self-lubricating oilite bronze.
Axles: 1/2" (13) dia. plated steel double bolted to blades.
Jackshaft: 1/2" (13) dia. cadmium plated steel.
Jamb Seals: Stainless steel.

Heat Responsive Device (Controlled Closure):

250°F (121°C) standard. 165°F (74°C) and 212°F (100°C) available.
 ERL (Electric Resettable Link) is standard on all dampers with electric actuators.

Sizes (Damper W x H):

Velocity/ Pressure Rating	Elevated Temp. °F	Minimum	Maximum
		Single Section Vertical	Single Section Vertical
24	250	8" x 8" (203 x 203)	48" x 36" (1219 x 914)

Notes:

1. Dampers with duct heights less than 8" (203) require a Type 'B' sleeve enclosure (Model 1222VB). Duct sizes less than 8" (203) in width require a Type 'C' enclosure (Model 1223VB).
2. Multiple Section Assemblies are not permitted.

BASE MODEL SELECTION:

- 1221VB** Standard factory sleeve (caulked to UL requirements) 16" long x 20 ga. (406 x 1.0).
- 1221VB** Non-standard sleeve. Specify _____ length _____ ga. Available up to 36" (914) dependent upon wall thickness and 10 through 20 ga. (3.5 through 1.0).

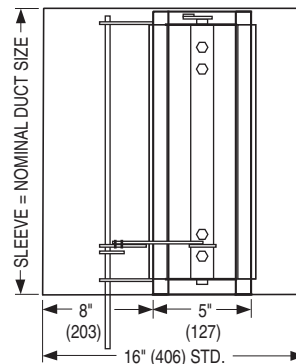
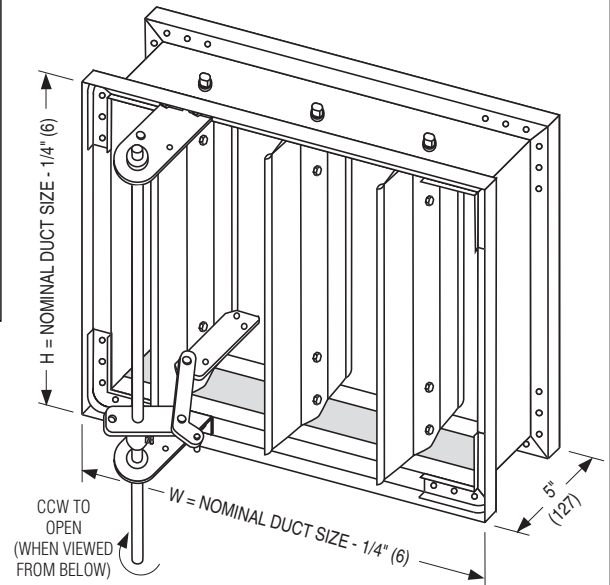

Wall Thickness	Minimum Sleeve Length
4 (102)	16 (406)
8 (203)	20 (508)
12 (305)	24 (610)
16 (406)	28 (711)

LEAKAGE CLASS/ELEVATED TEMPERATURE:

I II @ 250°F

DYNAMIC VELOCITY/PRESSURE RATING:

24 2000 fpm @ 4" w.g.

ACTUATOR SELECTION: Electric.

ACTUATOR LOCATION: External, bottom mount.

ACTUATOR FAIL POSITION: Closed.

OPTIONS:

- BS** Stainless steel bearings
- MLS-300** Position indicator switch pack
- MLS-400** Electric Fire Sensor (Re-openable control system). Includes dual heat sensors (165°F and 250°F) and position indicator switch pack.
- QS1** Quick-set retaining angle (one side)
- QS2** Quick-set retaining angles (two sides)
- TDF1** Flange (one end) } (22 or 20 ga. sleeves only)
- TDF2** Flange (both ends) }

SCHEDULE TYPE:

PROJECT:

ENGINEER:

CONTRACTOR:

For installation instructions, see IOM-1220VBINST.
 Dimensions are in inches (mm).

DATE	B SERIES	SUPERSEDES	DRAWING NO.
5 - 7 - 12	1200	11 - 12 - 08	1220VB-1



COMBINATION FIRE/SMOKE DAMPER
VERTICAL AIRFOIL BLADE
1 1/2 HOUR LABEL • ULTRA-LOW LEAKAGE
HIGH PERFORMANCE
MODEL: 1222VB (TYPE B SLEEVE ENCLOSURE)



FOR DUCTS UNDER 8" (203) IN HEIGHT AND 8" (203) OR MORE IN WIDTH

QUALIFICATIONS:

- **UL 555 & CAN/ULC-S112 CLASSIFIED DYNAMIC FIRE DAMPER** 1 1/2 hr. Label (File #'s R9492 & R19569).
- **UL 555S CLASSIFIED SMOKE DAMPER (File # R9492)** Leakage Class I or II at 250°F elevated temperature.
- **Meets NFPA 80, 90A, 92A, 92B, 101 and 105 as well as IBC and NBC (Canada) Building Code requirements.**
- **California State Fire Marshal Listing No. 03230-0935:106.**
- **City of New York. MEA # 366-03-M.**
- **Maximum velocity: 2000 fpm @ 4" w.g.**

Model 1222VB (Vertical Blade) is a high performance combination fire/smoke damper that provides superior protection and versatility. The vertical blade configuration allows for the actuator to be mounted below the damper and is ideal for applications where bottom access is desired or where there isn't space for a side mounted actuator.

The 1220VB Series dampers are ideal for applications where building codes require both a fire damper for the protection of ductwork penetrations in walls that have a fire resistance rating of up to 2 hours and also require a leakage rated damper for operational smoke control in static or dynamic smoke management systems.

The 1220VB Series has been especially designed and tested to provide premium performance. It offers the lowest leakage class available and is qualified for installation with airflow in either direction. Airfoil blade design and elimination of blade sills provide a low pressure drop design.

Unique, inter-locking double skin blade design provides flame and smoke seal under fire conditions at temperatures up to 2000°F.

STANDARD SPECIFICATION:

- Frame:** 5" x 7/8" x 16 ga. (127 x 22 x 1.6) galvanized steel hat channel.
Blades: 14 ga. (2.0) equivalent galvanized steel formed airfoil on 5 1/2" (140) centers. Opposed action.
Linkage: Concealed in frame. 12 ga. (2.7) plated steel.
Bearings: 1/2" (13) dia. self-lubricating oilite bronze.
Axles: 1/2" (13) dia. plated steel double bolted to blades.
Jackshaft: 1/2" (13) dia. cadmium plated steel.
Jamb Seals: Stainless steel.

Heat Responsive Device (Controlled Closure):

250°F (121°C) standard. 165°F (74°C) and 212°F (100°C) available.
 ERL (Electric Resettable Link) is standard on all dampers with electric actuators.

Sizes (Duct W x H):

Velocity/ Pressure Rating	Elevated Temp. °F	Minimum	Maximum
		Single Section Vertical	Single Section Vertical
24	250	8" x 4" (203 x 102) (overall damper height is 8" [203]).	48" x 7 1/2" (1219 x 191)

Notes:

1. Duct sizes less than 8" (203) in width require a Type 'C' enclosure (Model 1223VB).
2. Multiple Section Assemblies are not permitted.

SLEEVE/ENCLOSURE SELECTION:

- 1222VB** Standard factory sleeve (caulked to UL requirements) 16" long x 20 ga. (406 x 1.0).
- 1222VB** Non-standard sleeve. Specify _____ length _____ ga. Available up to 36" (914) dependent upon wall thickness and 10 through 20 ga. (3.5 through 1.0).

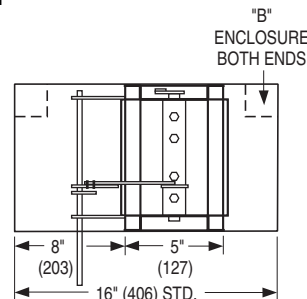
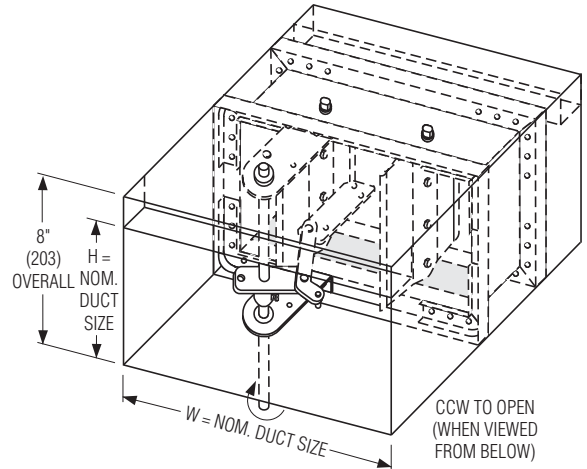

Wall Thickness	Minimum Sleeve Length
4 (102)	16 (406)
8 (203)	20 (508)
12 (305)	24 (610)
16 (406)	28 (711)

LEAKAGE CLASS/ELEVATED TEMPERATURE:

I II @ 250°F

DYNAMIC VELOCITY/PRESSURE RATING:

24 2000 fpm @ 4" w.g.

ACTUATOR SELECTION: Electric.

ACTUATOR LOCATION: External, bottom mount.

ACTUATOR FAIL POSITION: Closed.

OPTIONS:

- BS** Stainless steel bearings
- MLS-300** Position indicator switch pack
- MLS-400** Electric Fire Sensor (Re-openable control system). Includes dual heat sensors (165°F and 250°F) and position indicator switch pack.
- QS1** Quick-set retaining angle (one side)
- QS2** Quick-set retaining angles (two sides)

For installation instructions, see IOM-1220VBINST.
 Dimensions are in inches (mm).

SCHEDULE TYPE:				
PROJECT:				
ENGINEER:		DATE	B SERIES	SUPERSEDES
CONTRACTOR:		5 - 7 - 12	1200	11 - 12 - 08
				DRAWING NO.
				1220VB-2



COMBINATION FIRE/SMOKE DAMPER
VERTICAL AIRFOIL BLADE
HIGH PERFORMANCE
1 1/2 HR. LABEL • ROUND DUCT CONNECTION
MODEL: 1223VB (TYPE C SLEEVE ENCLOSURE)



QUALIFICATIONS:

- **UL 555 & CAN/ULC-S112 CLASSIFIED DYNAMIC FIRE DAMPER** 1 1/2 hr. Label (File #'s R9492 & R19569).
- **UL 555S CLASSIFIED SMOKE DAMPER** (File # R9492) Leakage Class I or II at 250°F elevated temperature.
- **Meets NFPA 80, 90A, 92A, 92B, 101 and 105 as well as IBC and NBC (Canada) Building Code requirements.**
- **California State Fire Marshal Listing No. 03230-0935:106.**
- **City of New York. MEA # 366-03-M.**
- **Maximum velocity: 2000 fpm @ 4" w.g.**

Model 1223VB (Vertical Blade) is a high performance combination fire/smoke damper that provides superior protection and versatility. The vertical blade configuration allows for the actuator to be mounted below the damper and is ideal for applications where bottom access is desired or where there isn't space for a side mounted actuator.

The 1220VB Series dampers are ideal for applications where building codes require both a fire damper for the protection of ductwork penetrations in walls that have a fire resistance rating of up to 2 hours and also require a leakage rated damper for operational smoke control in static or dynamic smoke management systems.

The 1220VB Series has been especially designed and tested to provide premium performance. It offers the lowest leakage class available and is qualified for installation with airflow in either direction. Airfoil blade design and elimination of blade sills provide a low pressure drop design.

Unique, inter-locking double skin blade design provides flame and smoke seal under fire conditions.

STANDARD SPECIFICATION:

- Frame:** 5" x 7/8" x 16 ga. (127 x 22 x 1.6) galvanized steel hat channel.
Blades: 14 ga. (2.0) equivalent galvanized steel formed airfoil on 5 1/2" (140) centers. Opposed action.
Linkage: Concealed in frame. 12 ga. (2.7) plated steel.
Bearings: 1/2" (13) dia. self-lubricating oilite bronze.
Axles: 1/2" (13) dia. plated steel double bolted to blades.
Jackshaft: 1/2" (13) dia. cadmium plated steel.
Jamb Seals: Stainless steel.

Heat Responsive Device (Controlled Closure):

250°F (121°C) standard. 165°F (74°C) and 212°F (100°C) available.
 ERL (Electric Resettable Link) is standard on all dampers with electric actuators.

Sizes (Duct Diameter):

Velocity/ Pressure Rating	Elevated Temp. °F	Minimum	Maximum
		Single Section Vertical	Single Section Vertical
24	250	4" (102) dia. (overall damper size is 8" x 8" [203 x 203]).	34" (864) dia.

Note: Multiple Section Assemblies are not permitted.

SLEEVE/ENCLOSURE SELECTION:

- 1223VB** Standard factory sleeve (caulked to UL requirements) 16" long x 20 ga. (406 x 1.0).
- 1223VB** Non-standard sleeve. Specify _____ length _____ ga. Available up to 36" (914) dependent upon wall thickness and 10 through 20 ga. (3.5 through 1.0).

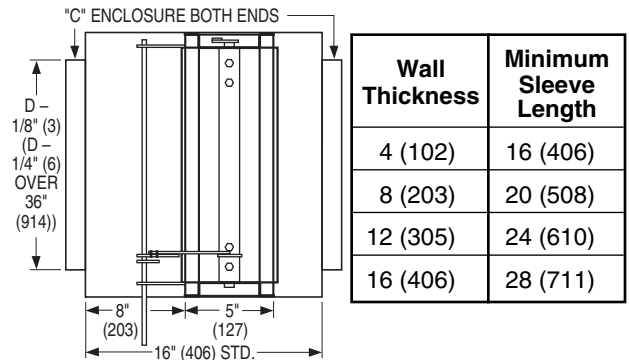
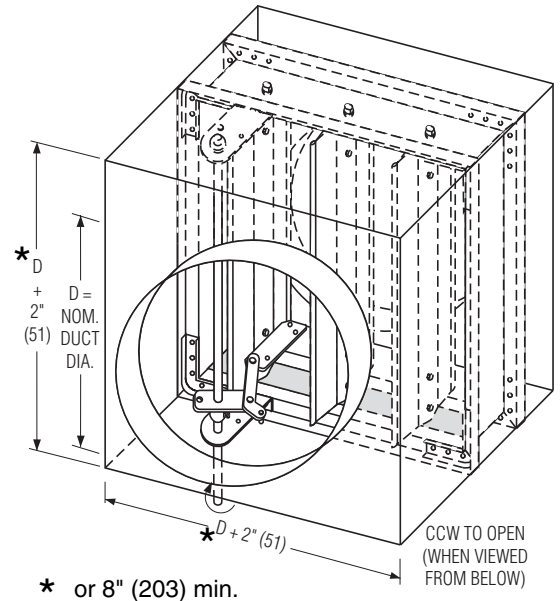

LEAKAGE CLASS/ELEVATED TEMPERATURE:

- I II @ 250°F

DYNAMIC VELOCITY/PRESSURE RATING:

24 2000 fpm @ 4" w.g.

ACTUATOR SELECTION: Electric.

ACTUATOR LOCATION: External, bottom mount.

ACTUATOR FAIL POSITION: Closed.

OPTIONS:

- BS** Stainless steel bearings
- MLS-300** Position indicator switch pack
- MLS-400** Electric Fire Sensor (Re-openable control system). Includes dual heat sensors (165°F and 250°F) and position indicator switch pack.
- QS1** Quick-set retaining angle (one side)
- QS2** Quick-set retaining angles (two sides)

For installation instructions, see IOM-1220VBINST.
 Dimensions are in inches (mm).

SCHEDULE TYPE:
PROJECT:
ENGINEER:
CONTRACTOR:

DATE	B SERIES	SUPERSEDES	DRAWING NO.
5 - 7 - 12	1200	11 - 12 - 08	1220VB-3



COMBINATION FIRE/SMOKE DAMPER
VERTICAL AIRFOIL BLADE
HIGH PERFORMANCE • 1 1/2 HR. LABEL
SQUARE, RECT. OR OVAL DUCT CONNECTION
MODEL: 1223VB (TYPE C SLEEVE ENCLOSURE)



QUALIFICATIONS:

- **UL 555 & CAN/ULC-S112 CLASSIFIED DYNAMIC FIRE DAMPER** 1 1/2 hr. Label (File #'s R9492 & R19569).
- **UL 555S CLASSIFIED SMOKE DAMPER (File # R9492)** Leakage Class I or II at 250°F elevated temperature.
- **Meets NFPA 80, 90A, 92A, 92B, 101 and 105 as well as IBC and NBC (Canada) Building Code requirements.**
- **California State Fire Marshal Listing No. 03230-0935:106.**
- **City of New York. MEA # 366-03-M.**
- **Maximum velocity: 2000 fpm @ 4" w.g.**

Model 1223VB (Vertical Blade) is a high performance combination fire/smoke damper that provides superior protection and versatility. The vertical blade configuration allows for the actuator to be mounted below the damper and is ideal for applications where bottom access is desired or where there isn't space for a side mounted actuator.

The 1220VB Series dampers are ideal for applications where building codes require both a fire damper for the protection of ductwork penetrations in walls that have a fire resistance rating of up to 2 hours and also require a leakage rated damper for operational smoke control in static or dynamic smoke management systems.

The 1220VB Series has been especially designed and tested to provide premium performance. It offers the lowest leakage class available and is qualified for installation with airflow in either direction. Airfoil blade design and elimination of blade sills provide a low pressure drop design.

Unique, inter-locking double skin blade design provides flame and smoke seal under fire conditions at temperatures up to 2000°F.

STANDARD SPECIFICATION:

- Frame:** 5" x 7/8" x 16 ga. (127 x 22 x 1.6) galvanized steel hat channel.
Blades: 14 ga. (2.0) equivalent galvanized steel formed airfoil on 5 1/2" (140) centers. Opposed action.
Linkage: Concealed in frame. 12 ga. (2.7) plated steel.
Bearings: 1/2" (13) dia. self-lubricating oilite bronze.
Axles: 1/2" (13) dia. plated steel double bolted to blades.
Jackshaft: 1/2" (13) dia. cadmium plated steel.
Jamb Seals: Stainless steel.

Heat Responsive Device (Controlled Closure):

250°F (121°C) standard. 165°F (74°C) and 212°F (100°C) available.
 ERL (Electric Resettable Link) is standard on all dampers with electric actuators.

Sizes (Duct W x H):

Velocity/ Pressure Rating	Elevated Temp. °F	Minimum	Maximum
		Single Section Vertical	Single Section Vertical
24	250	4" x 4" (102 x 102) (overall damper size is 8" x 8" [203 x 203] min.).	46" x 34" (1168 x 864)

Note: Multiple Section Assemblies are not permitted.

SLEEVE/ENCLOSURE SELECTION:

- 1223VB** Standard factory sleeve (caulked to UL requirements) 16" long x 20 ga. (406 x 1.0).
- 1223VB** Non-standard sleeve. Specify _____ length _____ ga. Available up to 36" (914) dependent upon wall thickness and 10 through 20 ga. (3.5 through 1.0).

LEAKAGE CLASS/ELEVATED TEMPERATURE:

- I II @ 250°F

DYNAMIC VELOCITY/PRESSURE RATING: 24 2000 fpm @ 4" w.g.

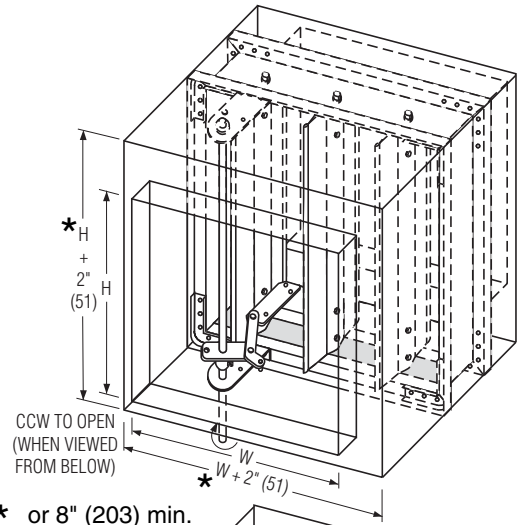

* or 8" (203) min.

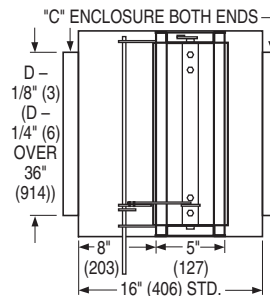
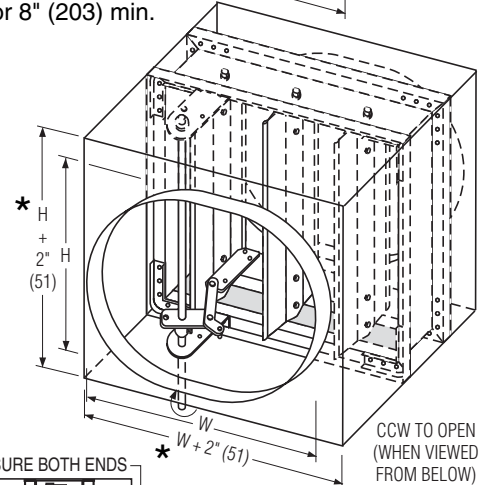

Wall Thickness	Min. Sleeve Length
4 (102)	16 (406)
8 (203)	20 (508)
12 (305)	24 (610)
16 (406)	28 (711)

ACTUATOR SELECTION: Electric.

ACTUATOR LOCATION: External, bottom mount.

ACTUATOR FAIL POSITION: Closed.

OPTIONS:

- BS** Stainless steel bearings
- MLS-300** Position indicator switch pack
- MLS-400** Electric Fire Sensor (Re-openable control system). Includes dual heat sensors (165°F and 250°F) and position indicator switch pack.
- QS1** Quick-set retaining angle (one side)
- QS2** Quick-set retaining angles (two sides)

For installation instructions, see IOM-1220VBINST.
 Dimensions are in inches (mm).

SCHEDULE TYPE:	DATE	B SERIES	SUPERSEDES	DRAWING NO.
PROJECT:	5 - 7 - 12	1200	11 - 12 - 08	1220VB-4
ENGINEER:				
CONTRACTOR:				

The DTS (Damper Test Switch) is an optional "momentary" push button test switch available on all Nailor smoke and combination fire/smoke dampers. The DTS provides the ability to "cycle test" the damper by pushing and holding down the button until the damper has cycled and closure has been visually verified, either by inspecting the damper through the access door or by confirmation at a remote control panel when equipped with the optional MLS-300 position indicator.

The DTS is mounted right on the damper and enables a single maintenance person to test and cycle the damper, eliminating the need for help from another person in the control room.

When a combination fire/smoke damper is ordered, the DTS is combined with the ERL (Electric Resettable Link), in a common enclosure.

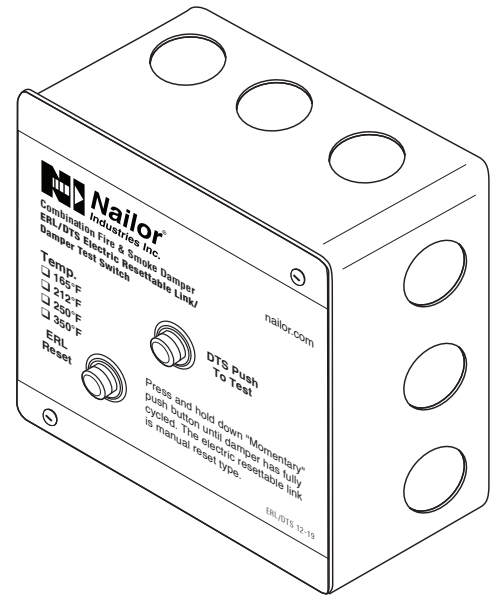

WIRING DIAGRAMS:

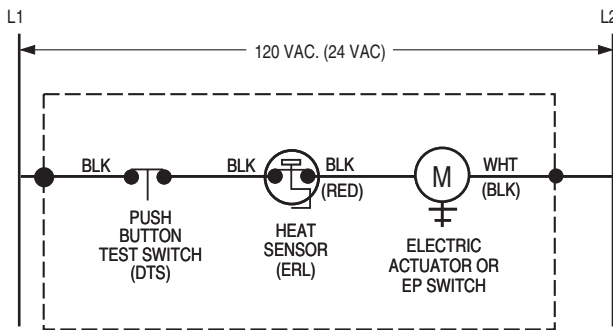

MOUNTED ON DAMPER (FACTORY WIRING TERMINATES AT SPLICE POINTS INDICATED INSIDE 4" x 4" ELECTRICAL BOX)

Figure 1. DTS/ERL Damper Test Switch with Electric Resettable Link

Belimo Actuator Aux. Switch Wiring Connections

Model Series	Open (OP)	Closed (CL)
FSTF	Orange / Gray	Violet / Red
FSLF / FSAFA	Gray / Gray	Violet / Violet
FSNF / FSAFB	White S4 / S6	White S1 / S2

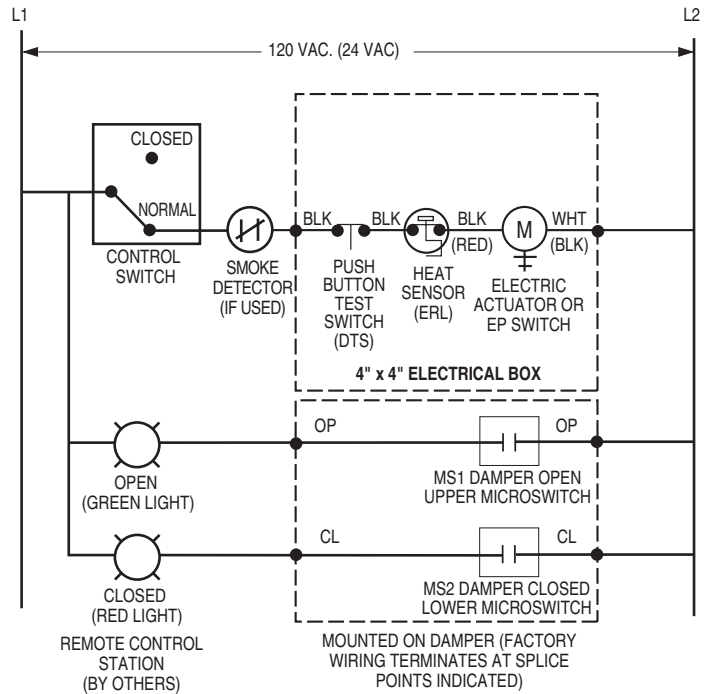

Figure 2. DTS/ERL with MLS-300 Belimo (actuator aux. switches) Position Indicator Package

SCHEDULE TYPE		Page 1 of 2			
PROJECT					
ENGINEER	DATE	B SERIES	SUPERSEDES	DRAWING NO.	
CONTRACTOR	9 - 3 - 20	FD-ACC	3 - 29 - 18	DTS	

WIRING DIAGRAMS:

Honeywell Actuator Aux. Switch Wiring Connections

Model Series	Open (OP)	Closed (CL)
MSXX04	Yellow / Yellow	Blue / Blue
MSXX20	Yellow / Yellow	Blue / Blue

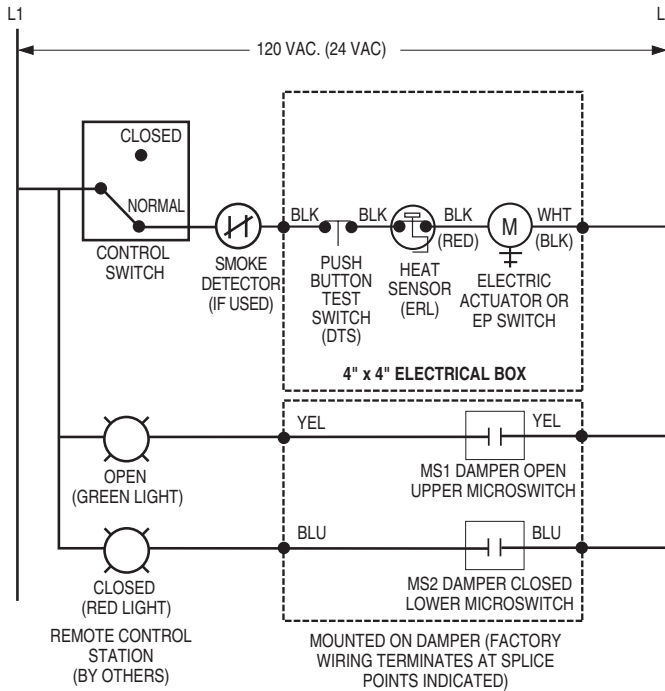

Figure 3. DTS/ERL with MLS-300 Nailor or Honeywell (actuator aux. switches) Position Indicator Package

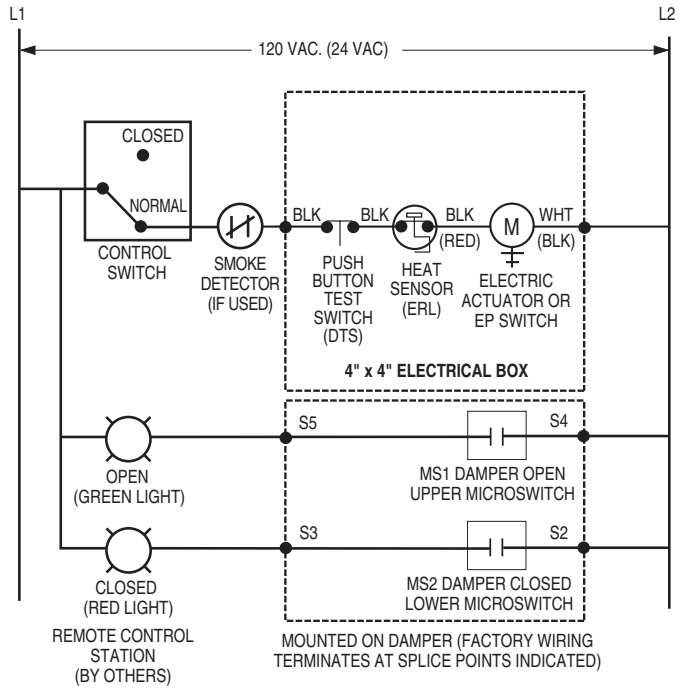
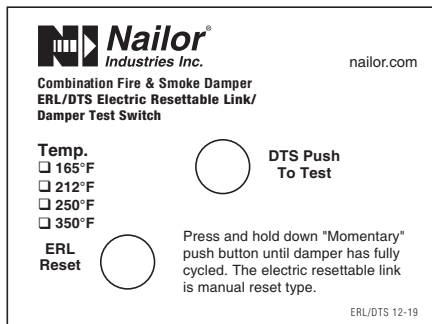
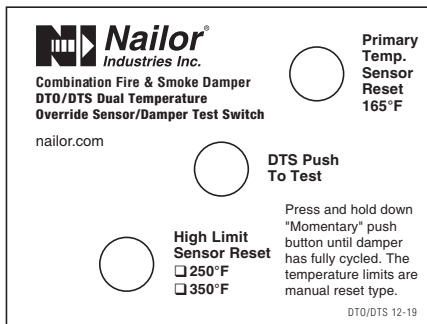

Figure 4. DTS/ERL with MLS-300 Siemens GJD Series (actuator auxiliary switches) Position Indicator Package

DTS LABEL VARIATIONS:



ERL/DTS Combination Fire/Smoke Damper



DTO/DTS Combination Fire/Smoke Damper

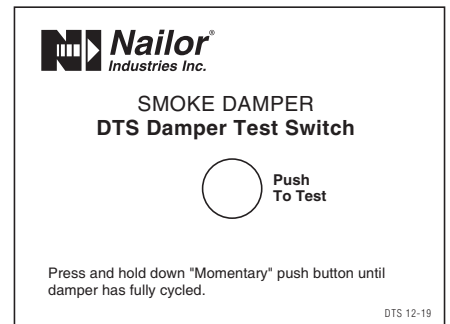

DTS Smoke Damper

SCHEDULE TYPE

PROJECT

ENGINEER

CONTRACTOR



ELECTRIC RESETTABLE LINK FOR COMBINATION FIRE / SMOKE DAMPERS MODEL: ERL

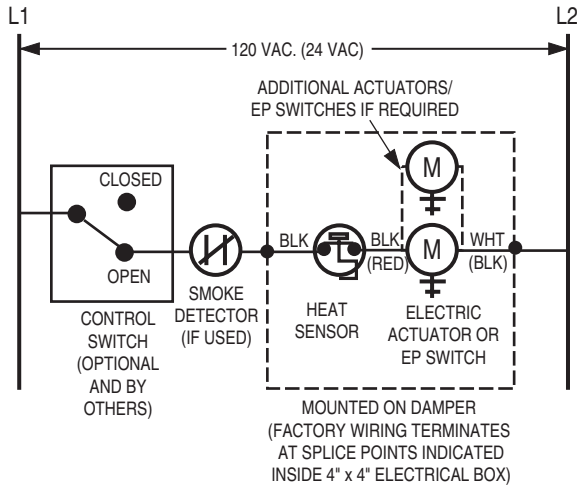

APPLICATION AND OPERATION:

The ERL Electric Resettable Link (heat sensor) is standard on all Nailor combination fire/smoke dampers with an electric actuator. The ERL is a thermally responsive bimetal disc/thermostat that opens and closes electrical contacts at a specific calibrated temperature. The ERL is a UL Classified Heat Responsive Device. The standard ERL has a fixed temperature setting of 250°F (121°C) which is the UL listed elevated/degradation temperature of the damper/actuator assembly. A 350°F (177°C) elevated temperature classification and ERL is available as an option.

[A 165°F and 212°F (74°C and 100°C) ERL are also available. Local codes have specified 165°F (74°C) widely in the past.]

The ERL's function is to sense an abnormally high temperature, as caused by a fire and allow the damper to close in order to prevent the spread of fire and smoke. The sensor interrupts power to the actuator and the actuator's spring return mechanism causes the damper to close and lock.

In smoke control mode, when a signal is detected via a normally closed smoke detector connection, the damper will close and remain closed until the smoke signal ceases. The system will then reset when power is re-applied and the damper will open. The damper may be closed at anytime by placing a control switch (optional and by others) in the closed position.

The ERL in combination with all Nailor qualified electric or pneumatic actuators provides controlled closure and eliminates the instantaneous damper closure associated with traditional fusible links that can cause damage to the ductwork.

The ERL sensor is of the manual reset type and can be reset after the temperature has cooled down below the sensor set point. Exposure to actual fire conditions may render these devices unusable. In this case, it is recommended that a careful inspection of the damper, actuator and ERL be performed.

The ERL requires factory installation and wiring together with the associated actuator to meet UL requirements. If the damper is provided with a pneumatic actuator, an EP switch is required.

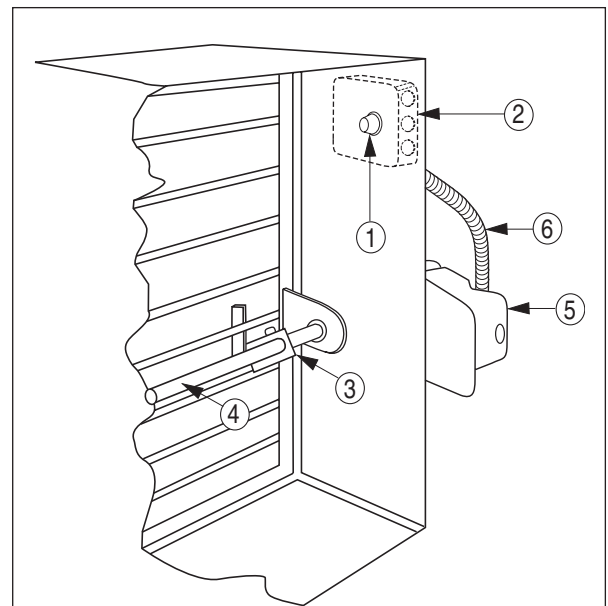

DESCRIPTION:

1. ERL 165, 212, 250, 350 Electric Resettable Link (heat sensor)
2. Electrical Junction Box (and EP Switch with Pneumatic Actuator)
3. Over-Center Knee Lock
4. Jackshaft
5. Actuator
6. Flexible Conduit

SCHEDULE TYPE

PROJECT

ENGINEER

CONTRACTOR

Dimensions are in inches (mm).

DATE

B SERIES

SUPERSEDES

DRAWING NO.

9 - 9 - 20

FD-ACC

9 - 23 - 02

ERL

**"QUICK-SET" RETAINING ANGLES BOTH SIMPLIFY AND SPEED INSTALLATION,
 SAVING BOTH TIME AND MONEY.**

BENEFITS:

- One piece angles are fastened together in the corners. Only two sets of angles to handle per damper (rather than four separate angles per side).
- Angles are shipped with damper - no sorting or matching.
- Provided with pre-drilled fastening holes on 2" (51) centers to ensure correct angle/sleeve attachment.
- Factory fabricated by Nailor to suit the individual fire damper.
- Reduced cost when compared to conventional retaining angles.
- Dampers can ship directly to the job site complete with all necessary installation sheet metal hardware (saves on double handling at contractor's shop).
- Help ensure a correct installation as per U.L. approved installation instructions.

The majority of installing contractors view fire damper installation as a costly time consuming and troublesome procedure. Eight conventional angles must be custom fabricated for each damper either in a sheet metal shop or at the job site and sized to suit each individual damper. Invariably, they are mislaid or lost and must be matched to each factory supplied damper.

The Nailor "Quick-Set" solution solves the majority of problems. They are pre-formed to fit and ship with the individual damper for ultimate convenience. "Quick-Set" angles are supplied with correctly spaced pre-drilled screw-holes to ensure a quick, easy and accurate installation for all integral sleeve Nailor fire and combination fire/smoke dampers - no measuring required.

"Quick-Set" retaining angles provide the "complete" installation package. Simple, fast, convenient.

MODELS:

Nailor "Quick-Set" retaining angles are an accessory option for all dampers ordered with factory sleeves.

QS2: Two sides (pair). For standard installations where angles are installed on both sides of the fire partition.

QS1: One side (single set). For use in single side retaining angle installations and with grille mount and "out of wall" damper models.

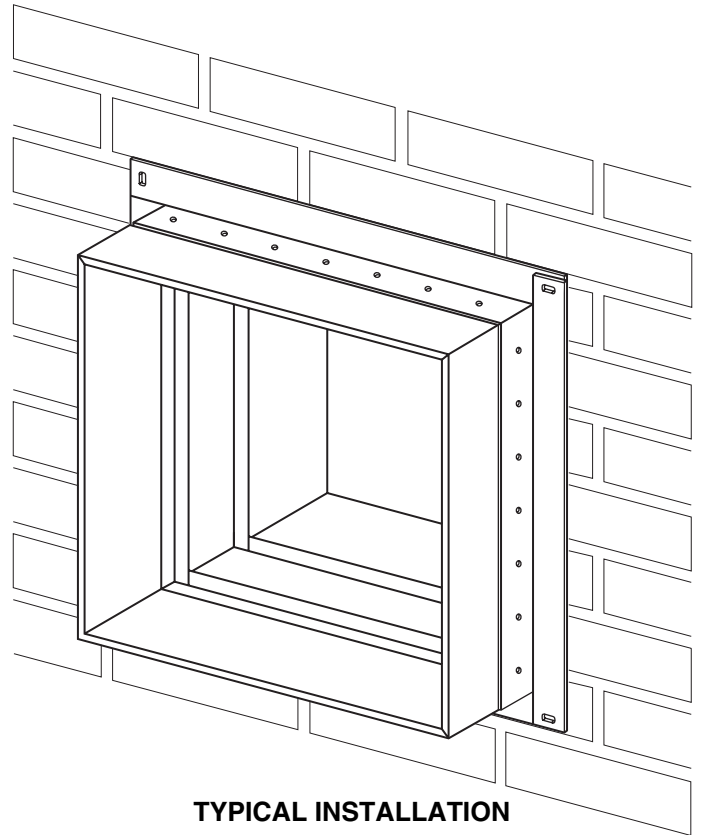

TYPICAL INSTALLATION

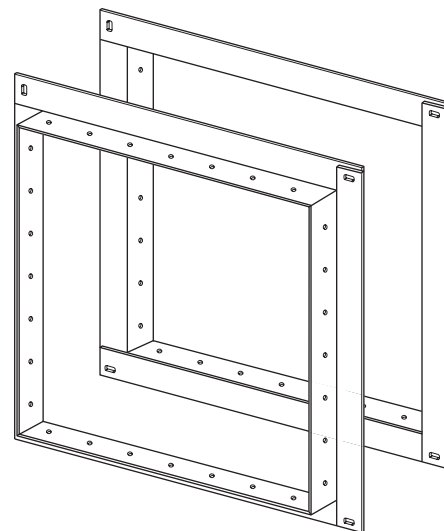

**TYPICAL PAIR OF PRE-ASSEMBLED
 QUICK-SET' RETAINING ANGLES**



SCHEDULE TYPE:
PROJECT:
ENGINEER:
CONTRACTOR:

Page 1 of 2			
Dimensions are in inches (mm).			
DATE	B SERIES	SUPERSEDES	DRAWING NO.
2 - 26 - 09	FD-ACC	6 - 5 - 03	QSRA

"QUICK-SET" RETAINING ANGLES
FOR ALL SLEEVED FIRE AND
COMBINATION FIRE/SMOKE DAMPERS
MODELS: QS1 AND QS2

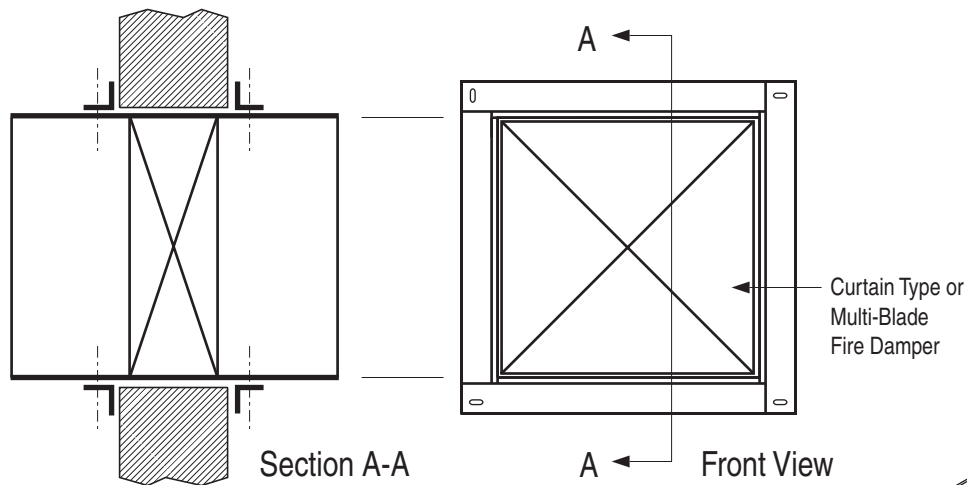

FIGURE 1. TYPICAL TWO SIDED INSTALLATION.

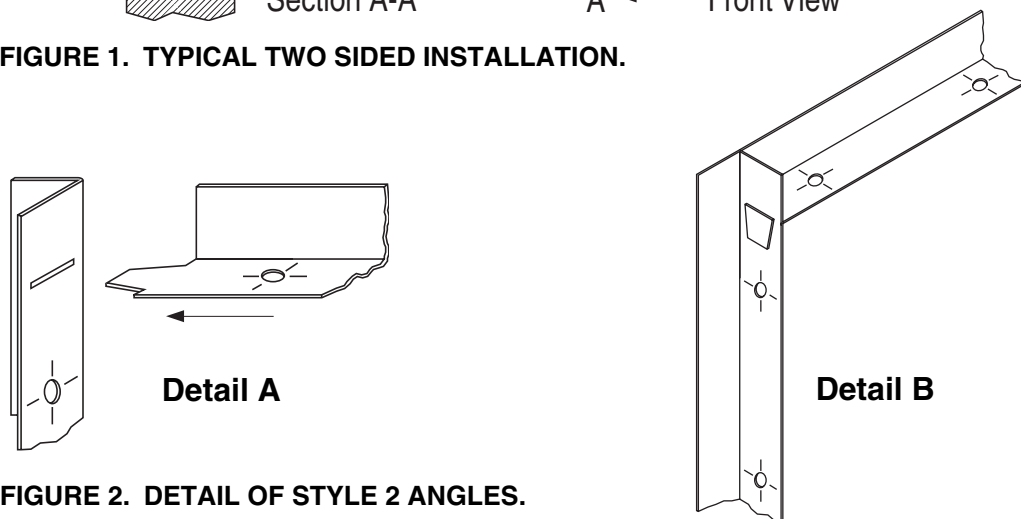

FIGURE 2. DETAIL OF STYLE 2 ANGLES.

APPLICATION:

The Nailor Quick-Set Retaining Angle System may be used in lieu of conventional retaining angles on all Nailor Fire and Combination Fire/Smoke Dampers.

Quick-Set angles are supplied in one of two styles, dependent upon fire resistance label, damper size and installation method.

Style 1: 1 1/2" x 1 1/2" x 20 ga. (38 x 38 x 1.0) Four sides are connected together with rivets in three corners.

Standard for the majority of applications with the following limitations:

- 1 1/2 hour label fire dampers.
- Maximum Size: 36" x 36" (914 x 914)
- Two sided installation only

Style 2: 1 1/2" x 1 1/2" x 16 ga. (38 x 38 x 1.6) Slot and tab design. The retaining angle assembly for each side has four angles, each with a tab end and a slot end (Detail A).

The tabs are to be inserted into the slots and knocked down either before or after fastening to the sleeve (Detail B).

- 1 1/2 or 3 hour label fire dampers
- Maximum Size: 90" x 48" (2286 x 1219) or 48" x 90" (1219 x 2286)
- Single side (1 1/2 hour only. Refer to Single Side Retaining Angles Supplementary Installation Instructions for size limitations) or two sided installation

Refer to the Following Installation Instructions:

Quick-Set Retaining Angles	FDQSRA
Curtain Type Fire Dampers (D)0100 & (D)0500	FDINST
Curtain Type Fire Dampers 0200 & 0500 Thinline	FDTINST
Multi-Blade Fire Dampers 1200 & 1250	MBFDINST
Combination Fire/Smoke Dampers 1220	1220INST
Combination Fire/Smoke Dampers 1270	1270INST
Single Side Retaining Angles	FDSSRAINST

SCHEDULE TYPE:		Page 2 of 2			
PROJECT:		Dimensions are in inches (mm).			
ENGINEER:		DATE	B SERIES	SUPERSEDES	DRAWING NO.
CONTRACTOR:		2 - 26 - 09	FD-ACC	5 - 5 - 03	QSRA

MS4120F; MS4620F; MS8120F; S2024-F; S20230-F Fast-Acting, Two-Position Actuators

PRODUCT DATA



FEATURES

- 175 lb-in. (20 Nm) minimum driving torque at 350°F (176°C).
- Reversible mounting facilitates use in either clockwise (cw) or counterclockwise (ccw) spring rotation.
- Integral spring return ensures level of return torque.
- Stainless steel internal spring.
- Fifteen-second spring return timing.
- No special cycling required during long-term holding. (See Operation section.)
- No audible noise during holding.
- Patent pending design eliminates need for limit switches to reduce power consumption.
- Models available for 24, 120, and 230 Vac applications.
- Ninety-five degree angle of rotation.
- Actuator holds rated torque at reduced power level.
- Die-cast aluminum housing.
- Housing design allows flush mounting to damper.
- Self-centering shaft adapter (SCSA), patent pending.
- Designed to operate reliably in smoke control systems requiring Underwriter's Laboratories Inc. UL555S ratings up to 350°F.

APPLICATION

The MS4120F, MS4620F, MS8120F, S2024-F, and S20230-F Fast-Acting, Two-Position Actuators are spring return direct coupled actuators (DCA) for on/off damper control. The actuator accepts an on/off signal from a single-pole, single-throw (spst) controller. Reversible mounting allows actuator to be used for either clockwise (cw) or counterclockwise (ccw) spring rotation.

Designed to operate reliably in smoke control systems requiring Underwriter's Laboratories Inc. UL555S ratings up to 350°F.

MS4120F, MS4620F, MS8120F

- High temperature Teflon® lead wires.
- Models available with integral high temperature (350°F) SPST position-indicating switches (7°, 85° stroke).

APPLICABLE LITERATURE

— Specification Data Sheet	63-2592
— Motor/Actuator Selection Guide for Damper Applications	63-8419
— Engineering Manual of Automatic Control (also called The Gray Manual)	77-1100
— Direct Coupled Actuator Quick Selection Guide	63-8553
— Damper Torque Calculator	63-8437

S2024-F, S20230-F

- Double-insulation rating.
- High-temperature, halogen-free, silicone-free leadwires.
- Models available with integral high temperature (350°F) SPDT position-indicating switches (7°, 85° stroke).



SPECIFICATIONS

Models: See Tables 1, 2, and 3.

Table 1. Models.

Model	Voltage in Vac	Internal Auxiliary Switches
MS4120F1006	120	None
MS4120F1204	120	2 SPST ^a
MS4620F1005	230	None
MS4620F1203	230	2 SPST ^a
MS8120F1002	24	None
MS8120F1200	24	2 SPST ^a
S2024-F (MS8120S1006)	24	None
S20230-F (MS4620S1009)	230	
S2024-F-SW2 (MS8120S1204)	24	2 SPDT ^a
S20230-F-SW2 (MS4620S1207)	230	

^a Internal switches are designed to pass UL555S requirements (at 350°F).

Dimensions: See Fig. 1.

Device Weight:

MS4120F, MS4620F, S20230-F: 7.5 lb (3.4 kg)
 MS8120F, S2024-F: 6.25 lb (2.8 kg)

Stroke: 95° ± 3°, mechanically limited.

Electrical Ratings:

Power Input:
 MS4120F: 120 Vac ±10%, 60 Hz.
 MS4620F,S; S20230-F: 230 Vac ±10%, 50/60 Hz.
 MS8120F,S; S2024-F: 24 Vac +20%, -10%, 50/60 Hz (Class 2).
 Power Consumption:
 MS4120F: Driving: 0.35A, 35W. Holding: 0.15A, 10W.
 MS4620F,S; S20230-F:
 Driving: 0.20A, 35W. Holding: 0.14A, 10W.
 MS8120F,S; S2024-F: Driving: 45 VA. Holding: 10 VA.

Electrical Connections:

Lead Wires:
 MS4120F, MS4620F, MS8120F: 1m Teflon wire.
 MS4620S, MS8120S, S2024-F, S20230-F: 1m halogen-free, silicone-free wire.
 Two integral 3/8 in. flexible conduit connections.

Timing (At Rated Torque and Voltage):

Drive Open: 15 seconds typical.
 Spring Close: 15 seconds typical.

Auxiliary Switches:

Dry Contact
 Ratings (maximum load): 250 Vac, 5A resistive.
 Settings (fixed): 7° nominal stroke, 85° nominal stroke.

Torque Rating (at Rated Voltage):

Typical Holding (minimum at 350°F): 175 lb-in. (20 Nm).
 Spring Return (minimum at 350°F): 175 lb-in. (20 Nm).
 Stall Maximum (fully open at 75°F): 425 lb-in. (48.0 Nm).
 350°F Minimum Driving: 175 lb-in. (20 Nm).

Design Life (at Rated Voltage): 30,000 full stroke cycles.

Minimum Damper Shaft Length:

1 in. (25 mm); 3-1/4 (83 mm) recommended.

Cycling Requirements:

Prolonged holding-period (1 year) testing of these actuators has been performed with no spring return failures. The actuator and the internal spring are designed to require no special cycling during long-term holding.
 Honeywell recommends following all local, state and national codes for periodic testing of the entire smoke control system. Refer to National Fire Protection Association (NFPA) National Fire Codes®: NFPA90A, NFPA92A and NFPA92B for your application.
 NFPA recommends periodic examination of each fire/smoke damper (semi-annually or annually) to ensure proper performance.

Mounting: Self-centering shaft adapter.

Round Damper Shafts: 0.5 to 1.06 in.
 Square Damper Shafts: 1/2 to 3/4 in.
 Actuator can be mounted with shaft in any position.

IMPORTANT

- Honeywell does not recommend using linkages with these actuators because side-loading of the output hub reduces actuator life.
- 3/4 in. or greater shaft diameter recommended.

Noise Rating at 1m (Maximum):

Driving or Spring Return: 70 dBA.
 Holding: 20 dBA (no audible noise).

Vibration:

Not suitable for high vibration applications (Example installation environment: Truck Trailers or Railroad Cars)
 Acceptable Vibration Levels 0.6g at 30 to 300 Hz.

Temperature Ratings:

Ambient: -40°F to 130°F (-40°C to 55°C).
 Shipping and Storage: -40°F to 140°F (-40°C to 60°C).

IMPORTANT

The actuator is designed to meet UL555S standards at 350°F (176°C). The actuator must be tested with the damper to achieve this rating.

NOTE: The actuator is designed to operate for 30 minutes during a one-time excursion to 350°F (176°C).

Humidity Ratings: 5% to 95% RH noncondensing.

Environmental Protection Ratings:

NEMA2 and IP54 when mounted on a horizontal shaft and the base of the actuator below the shaft.

Accessories:

205649 Mounting Bracket (not supplied with actuator).

Approvals: See Table 4.

Controller Type:

MS4120F: Line voltage (120 Vac), 2-position, spst (Series 40).
 MS4620F,S; S20230-F: Line voltage (230 Vac), 2-position, spst (Series 40).
 MS8120F,S; S2024-F: Low voltage (24 Vac), 2-position, spst (Series 80).

Table 2. Actuator Selection (MS Series)

M	Electrical Motor
S	Fail Safe Function (Spring Return)
41	120 Vac 2-position Control; Reversible Mount Spring Return
46	230 Vac 2-position Control; Reversible Mount Spring Return
81	24 Vac 2-position Control; Reversible Mount Spring Return
20	175 lb-in. (20 Nm)
F	Fire and Smoke (US)
1	No Feedback
0	No Auxiliary Switches
2	Two Auxiliary Switches
XX	System Controlled Numbers

M S 41 20 F 1 2 XX

Table 3. Actuator Selection (S20 Series).

S	Fail Safe Function (Spring Return)
20	20 Nm (175 lb-in.)
24	24 Vac 2-position Control; Reversible Mount Spring Return
230	230 Vac 2-position Control; Reversible Mount Spring Return
F	Fire and Smoke Actuator
	No Auxiliary Switches
-SW2	Two Auxiliary Switches

S 20 24 - F -SW2

Table 4. Approvals.

	MS4120F	MS4620F, MS8120F	S20230-F	S2024F
UL/cUL	X	X		
UL873 Plenum Rating, File No. E4436; Guide No. XAPX. ^a	X	X		
CE		X	X	
C-TICK		X	X	X

^a Plenum applications require that conductors be enclosed in conduit (see Wiring section for conduit details).

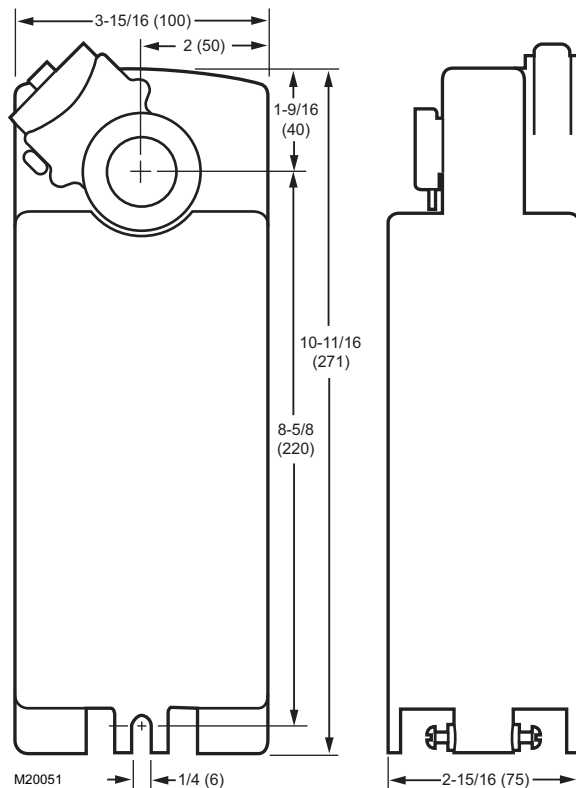

Fig. 1. Dimensional drawing of actuator in in. (mm).

INSTALLATION

When Installing this Product...

1. Read these instructions carefully. Failure to follow them could damage the product or cause a hazardous condition.
2. Check the ratings given in the instructions and on the product to make sure the product is suitable for your application.
3. Installer must be a trained, experienced service technician.
4. After installation is complete, check out product operation as provided in these instructions.

WARNING

Electrical Power Hazard.
Line voltage can cause death or serious injury and short equipment circuitry.
Disconnect power supply before installation.



CAUTION

Electrical Shock or Equipment Damage Hazard.
Low voltage can shock individuals or short equipment circuitry.
Disconnect power supply before installation.

IMPORTANT

All wiring must agree with applicable codes, ordinances and regulations.

Location

The actuators are designed to open a damper by driving the damper shaft in either a clockwise  or counterclockwise  direction. The actuator housing has two slots on the bottom, either of which, with a 205649 Mounting Bracket, secures it flush to a damper box (see Fig. 2).

NOTE: When mounted correctly, these slots allow the actuator to float without rotating relative to the damper shaft.

CAUTION

Equipment Damage Hazard.
Tightly securing actuator to damper housing can damage actuator.
Mount actuator to allow it to float along its vertical axis.

Preparation

Before mounting the actuator onto the damper shaft, determine the:

- Damper/valve opening direction for correct spring return rotation. The actuator can be mounted to provide clockwise or counterclockwise spring return.
- Damper shaft size (see Specifications section).

Determine Appropriate Mounting Orientation

See Fig. 2 for mounting orientation.

NOTES:

- Actuators are shipped in the fully closed position.
- An arrow molded into the hub points to tick marks on the label to indicate the hub rotary position.
- See Fig. 3 for proper mounting to a square damper shaft.

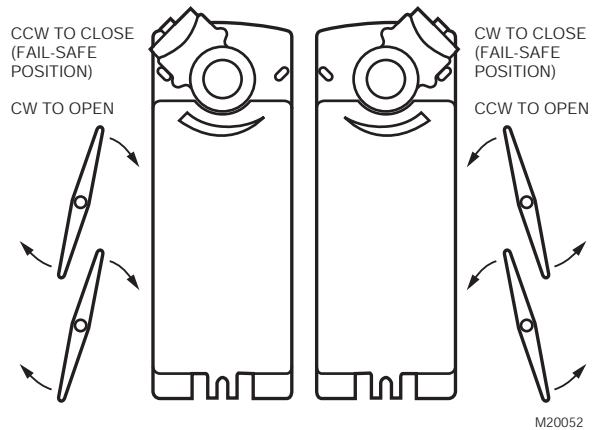

Fig. 2. Spring Return DCA mounting orientation.

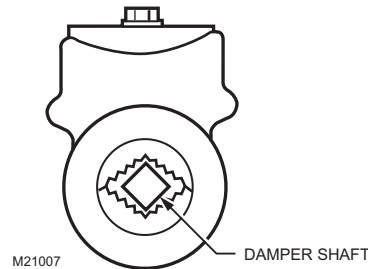

Fig. 3. Proper mounting to square damper shaft.

Measure Damper/Valve Shaft Length

If the shaft is less than three inches in length, the shaft coupling must be located between the damper/valve and actuator housing. If the shaft length is more than three inches, the shaft coupling may be located on either side of the actuator housing.

If the coupling must be moved from one side of the actuator to the reverse, follow these instructions (see Fig. 4):

1. Remove the retainer clip from the shaft coupling and set it aside for later use.
2. Remove shaft coupling from one side of the actuator.
3. Replace the shaft coupling on the opposite side of the actuator aligning it based on the stroke labelling.
4. Replace the retainer clip on the shaft coupling using the groove of the coupling.

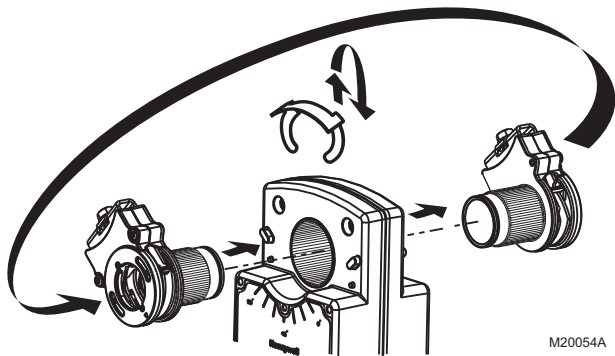

M20054A

Fig. 4. Mounting shaft coupling to actuator opposite side.

Mounting



CAUTION

Device Malfunction Hazard.
Improper shaft coupling tightening causes device malfunction.
 Tighten shaft coupling with proper torque to prevent damper shaft slippage.



CAUTION

Actuator Damage Hazard.
Using actuator as shaft bearing causes device damage.
 Use actuator only to supply rotational torque. Avoid any side loads to actuator output coupling bearings.

To mount actuator, proceed as follows:

1. Place actuator over damper shaft; and hold mounting bracket in place. See Fig. 5.
2. Mark screw holes on damper housing.
3. Remove actuator and mounting bracket.
4. Drill or center-punch holes for mounting screws (or use no.10 self-tapping sheet metal screws).

NOTE: If necessary, use a field-fabricated steel base plate secured with sheet metal screws.

5. Turn damper blades to desired normal (closed) position.
6. Place actuator and mounting bracket back into position and secure bracket to damper box with sheet metal screws.
7. Using 10 mm wrench, tighten shaft coupling securely onto damper shaft using minimum 120 lb-in., maximum 180 lb-in. torque.

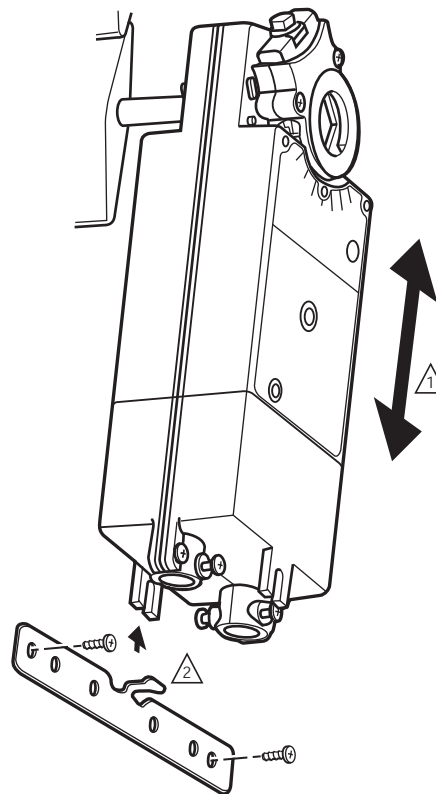

1 ENSURE THAT MOUNTING ASSEMBLY PREVENTS ACTUATOR ROTATION AND ALLOWS ACTUATOR TO FLOAT ALONG INDICATED AXIS. WHEN TOO TIGHT, THE RESULTING BINDING CAN DAMAGE THE ACTUATOR OR REDUCE TORQUE OUTPUT.

2 ACCESSORY MOUNTING BRACKET IS NOT SUPPLIED WITH THE ACTUATOR.

M20055

Fig. 5. Mounting actuator to damper housing.

Manual Positioning

The actuator can be operated with no power present. Use this feature during installation or to move and lock the damper or valve shaft position when there is no power.

To operate the manual positioning:

1. If the power is on, turn it off.
2. Insert supplied hex wrench (key) as shown in Fig. 6.
3. Rotate key in the direction indicated on the cover.
4. Once the desired position is reached, hold the key to prevent the spring return from moving the actuator.

NOTE: No detente for fire and smoke actuators. If key is released, actuator will return to spring closed position.

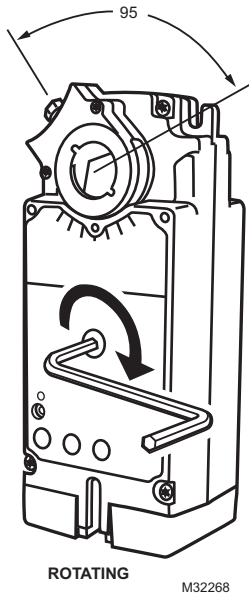

Fig. 6. Manual positioning.

WIRING

See Fig. 7 through 11 for typical wiring diagrams.

⚠ WARNING

Electrical Power Hazard.
Line voltage can cause death or serious injury and short equipment circuitry.
Disconnect power supply before installation.

⚠ CAUTION

Electrical Shock or Equipment Damage Hazard.
Disconnect all power supplies before installation.
Motors with auxiliary switches can have more than one disconnect.

IMPORTANT

1. All wiring must comply with local electrical codes, ordinances and regulations.
2. Voltage and frequency of transformer used with MS8120F,S and S2024-F must correspond with the characteristics of power supply and actuator.

NOTE: The conduit fittings are designed for use with 3/8 in. reduced-wall steel or aluminum flexible conduit.

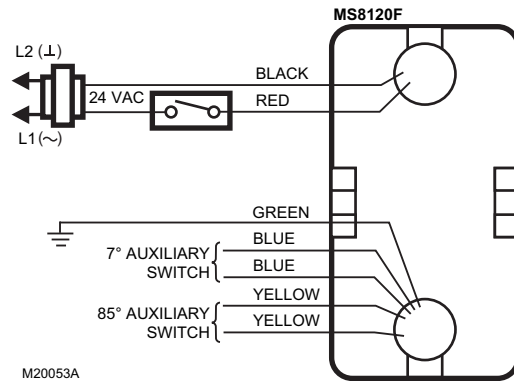

Fig. 7. Typical 24 Vac wiring (MS Series).

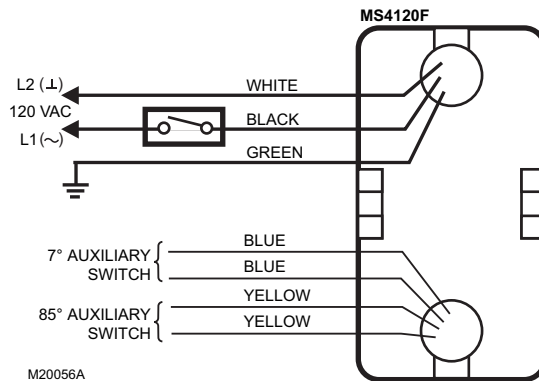

Fig. 8. Typical 120 Vac wiring (MS Series).

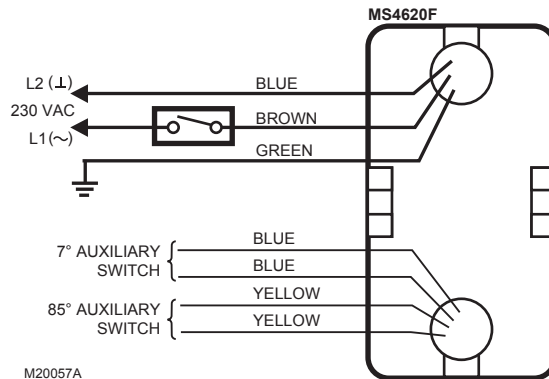

Fig. 9. Typical 230 Vac wiring (MS Series).

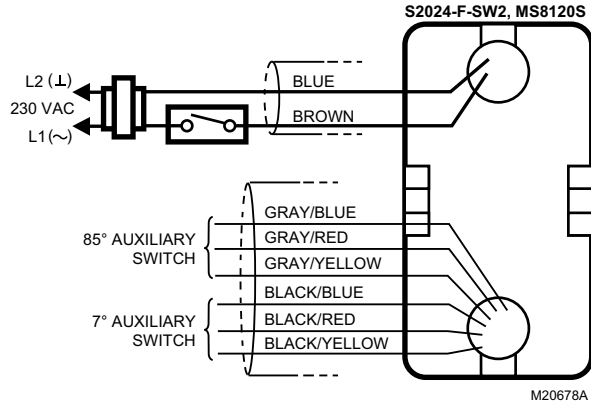

Fig. 10. Typical 24 Vac wiring (S20 Series).

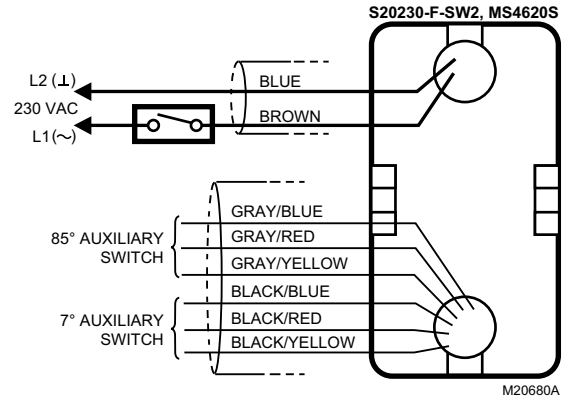

Fig. 11. Typical 230 Vac wiring (S20 Series).

OPERATION

The actuators are designed for use in Smoke Control Systems. If power fails, the actuator spring returns to the 0° position. The actuator mounts flush with the damper box. The actuator drives from 0° to 95° and spring returns back to 0°.

The actuators are operated by an spst two-position controller. When using an spst two-position controller, the actuator drives to the damper fully open position when controller contact makes and spring returns to the damper fully closed position when controller contact breaks. The actuator drops to holding power level on detection of stall, independent of hub position.

Cycling

The actuator and the internal spring are designed so that no special cycling during long-term holding is required. Honeywell recommends following all local, state, and national codes for periodic testing of the entire smoke control system. Refer to National Fire Protection Association (NFPA) National Fire Codes®: NFPA90A, NFPA92A, and NFPA92B for your application.

Auxiliary Switches

Some models include auxiliary switches (see Table 1).

SPST Switches (Table 5)

See Fig. 7 through 9 for SPST auxiliary switch wiring.

Table 5. SPST Auxiliary Switch Operation.

Switch	Wire Color	Makes	Breaks
		(degrees from fully closed position)	
7°	blue	less than 7	greater than 7
85°	yellow	greater than 85	less than 85

NOTE: Both sets of contacts are open when the actuator is between 7° and 85°.

SPDT Switches (Fig. 12)

See Fig. 10 through 12 for SPDT auxiliary switch wiring.



Fig. 12. SPDT auxiliary switch operation.

CHECKOUT

MS4120F (120 Vac model)

1. Check damper position.
2. Connect 120 Vac to the black and white leadwires to drive the damper to the open position. The actuator should drive the damper.
3. If the actuator does not run, remove power for at least two seconds.
4. If the actuator spring returns, allow it to close entirely, then return to step 2.
5. If the actuator does not spring return, verify that the actuator is properly installed. See Installation section.
6. If the actuator is correctly installed but neither runs nor spring returns, replace the actuator.

MS4620F; S20230-F (230 Vac models)

1. Check damper position.
2. Connect 230 Vac to the blue and brown leadwires to drive the damper to the open position. The actuator should drive the damper.
3. If the actuator does not run, remove power for at least two seconds.
4. If the actuator spring returns, allow it to close entirely, then return to step 2.
5. If the actuator does not spring return, verify that the actuator is properly installed. See Installation section.
6. If the actuator is correctly installed but neither runs nor spring returns, replace the actuator.

MS8120F; S2024-F (24 Vac models)

1. Check damper position.
2. Connect 24 Vac to the red and black leadwires to drive the damper to the open position. The actuator should drive the damper.
3. If the actuator does not run, remove power for at least two seconds.
4. If the actuator spring returns, allow it to close entirely, then return to step 2.
5. If the actuator does not spring return, verify that the actuator is properly installed. See Installation section.
6. If the actuator is correctly installed but neither runs nor spring returns, replace the actuator.

D Montageanweisung
 F Instructions d'Installation
 I Istruzioni per l'Installazione

NL Installatievoorschrift
 DK Installasjonsinstruks
 N Installationsinstruktioner

SF Asennusohje
 S Installations Instruktioner
 E Instrucciones de montaje

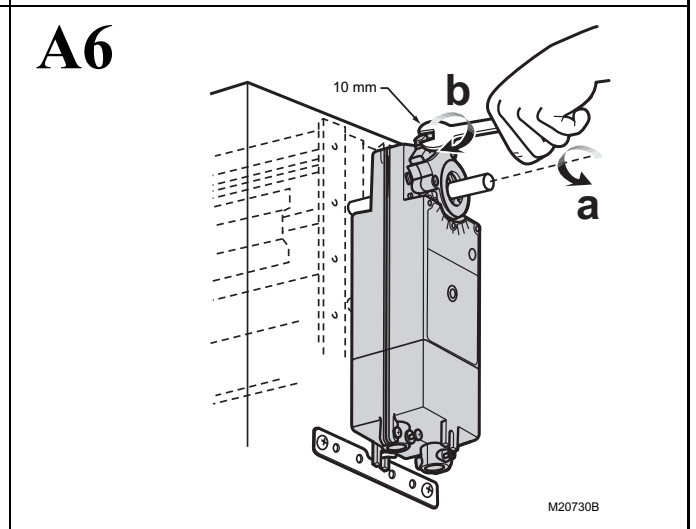
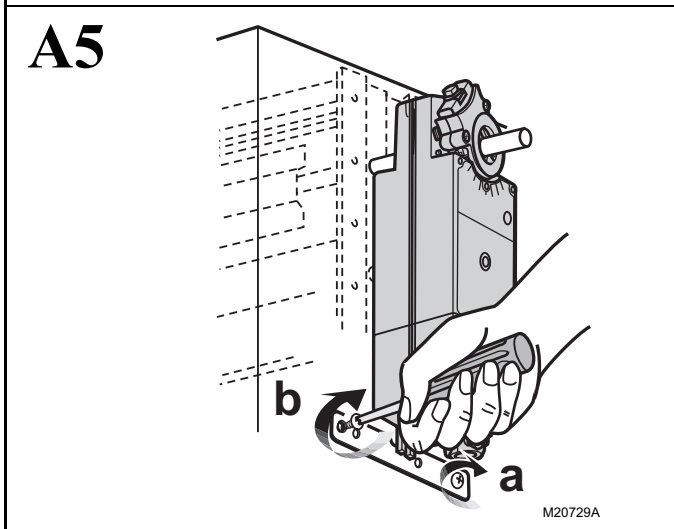
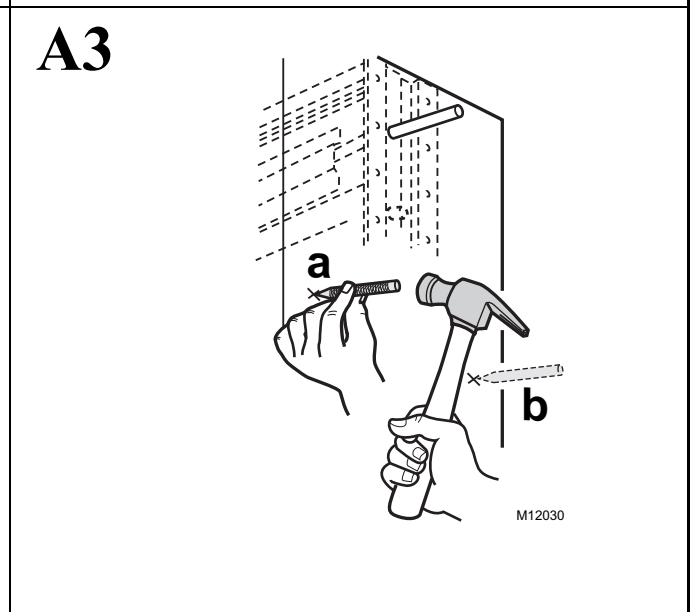
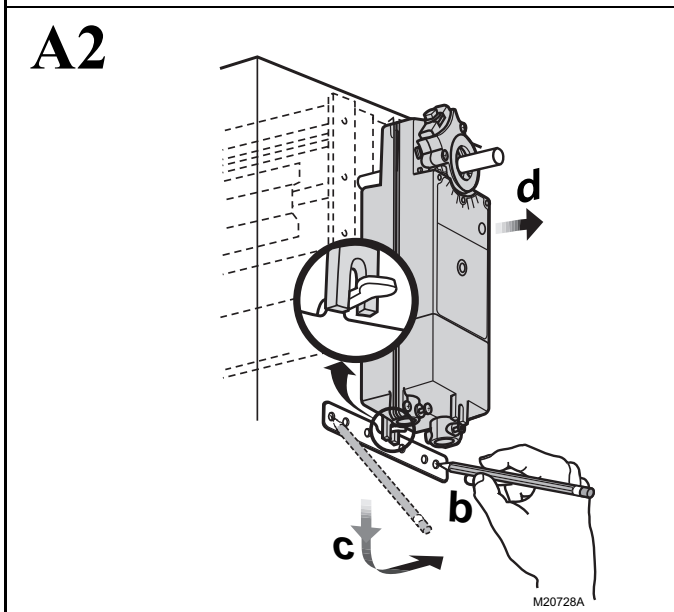
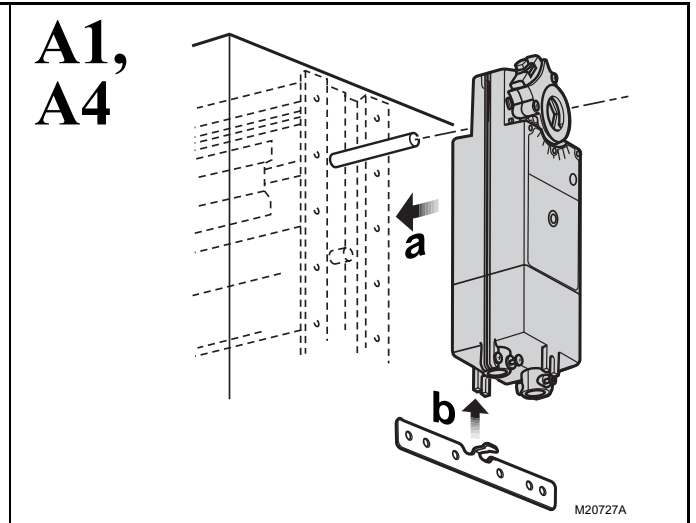
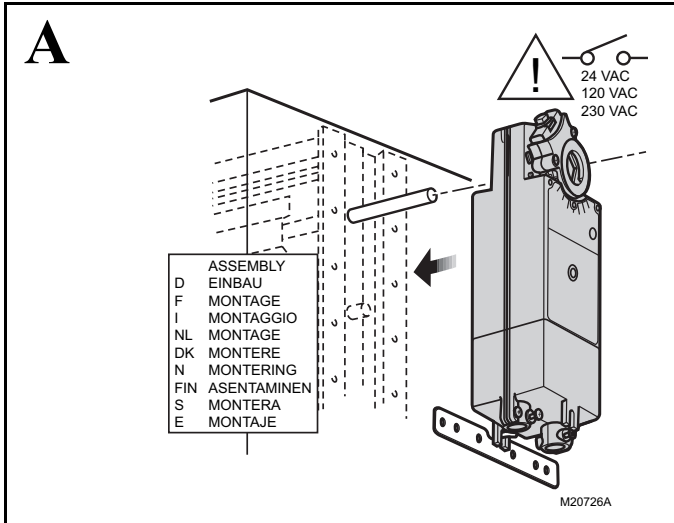

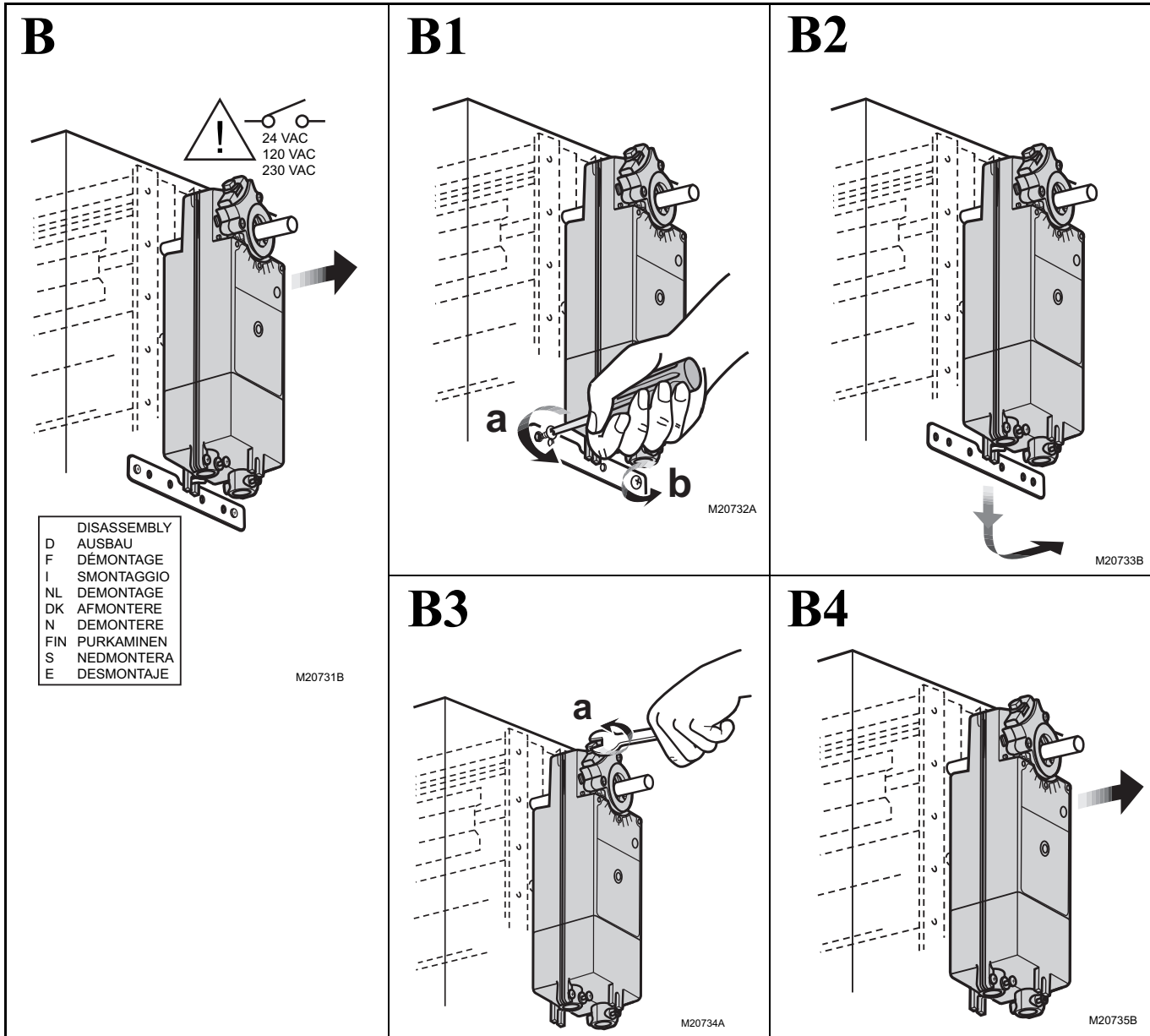

MS4120F; MS4620F; MS8120F; S2024-F; S20230-F FAST-ACTING, TWO-POSITION ACTUATORS

Teflon® is a registered trademark of the E.I. du Pont de Nemours and Company.

National Fire Codes® is a registered trademark of the National Fire Protection Association (NFPA).

Automation and Control Solutions

Honeywell International Inc.
1985 Douglas Drive North
Golden Valley, MN 55422
customer.honeywell.com

© U.S. Registered Trademark
© 2012 Honeywell International Inc.
63-2584—10 M.S. Rev. 03-12
Printed in United States

Honeywell

MS4104, MS4109, MS4604, MS4609, MS8104, MS8109 Fast-Acting, Two-Position Actuators

FOR FIRE/SMOKE CONTROL APPLICATIONS

PRODUCT DATA



FEATURES

- 30 lb-in. (3.4 N•m) or 80 lb-in. (9 N•m) minimum driving torque at 350°F (176°C).
- Reversible mounting facilitates use in either clockwise (cw) or counterclockwise (ccw) spring rotation.
- Integral spring return ensures level of return torque.
- Fifteen-second spring return timing.
- No special cycling required during long-term holding. (See Operation section.)
- No audible noise during holding.
- Patent pending design eliminates need for limit switches to reduce power consumption.
- Models available for 24, 120, and 230 Vac.
- Ninety-five degree angle of rotation.
- Actuator holds rated torque at reduced power level.
- Die-cast aluminum housing.
- Housing design allows flush mounting to damper.
- Designed to operate reliably in smoke control systems requiring Underwriter’s Laboratories Inc. UL555S ratings up to 350°F.
- Models available with SPST position-indicating switches (7°, 85° stroke).

APPLICATION

The MS4104, MS4109, MS4604, MS4609, MS8104 and MS8109 Fast-Acting, Two-Position Actuators are spring return direct coupled actuators (DCA) for Fire and Smoke dampers (on/off control). The actuator accepts an on/off signal from a single-pole, single-throw (SPST) controller. Reversible mounting allows actuator to be used for either clockwise (cw) or counterclockwise (ccw) spring rotation.

Contents

Application	1
Features	1
Specifications	2
Ordering Information	2
Installation	4
Operation	6
Checkout	6

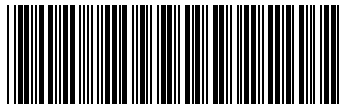

63-2740-05

SPECIFICATIONS

Models: See Table 1.

Table 1. Models.

Model	Voltage (Vac)	Internal Auxiliary Switches
MS4104F1010	120	None
MS4104F1210	120	2 SPST ^a
MS4109F1010	120	None
MS4109F1210	120	2 SPST ^a
MS4604F1010	230	None
MS4604F1210	230	2 SPST ^a
MS4609F1010	230	None
MS4609F1210	230	2 SPST ^a
MS8104F1010	24	None
MS8104F1210	24	2 SPST ^a
MS8109F1010	24	None
MS8109F1210	24	2 SPST ^a

^a Internal switches are designed to pass UL555S requirements (at 350°F for 30 minutes) and are intended for use as position indication.

Dimensions: See Fig. 1.

Minimum Damper Shaft Length: 2 in. (51 mm).

Device Weight: 5 lb (2.3 kg).

Stroke: 95° ± 3°, mechanically limited.

Electrical Ratings: See Table 2.

Electrical Connections:

Power Lead Wires:

MS410xF and MS460xF: 32 inches (0.8m), 18 AWG

MS810xF: 39 inches (1m), 18 AWG

Switch Lead Wires: 18 inches, 18 AWG, 2 color coded leads

Mounting: Round 1/2 inch shaft adapter with 1/4 inch set screws.

Threads: ¼-20 UNC-2A

Material: Alloy Steel hardened to HRC 45-53

Thread Lock: Nylon Patch

IMPORTANT

Honeywell does not recommend using linkages with these actuators because side-loading of the output hub reduces actuator life.

Temperature Ratings:

Ambient: 0°F to 130°F (-18°C to 55°C).

Shipping and Storage: -40°F to 140°F (-40°C to 60°C).

IMPORTANT

The actuator is designed to meet UL555S standards at 350°F (176°C). The actuator must be tested with the damper to achieve this rating.

Humidity Ratings: 5% to 95% RH noncondensing.

Noise Rating (Maximum):

Driving Open: 75 dBA at 1m.

Holding: 20 dBA at 1m (no audible noise).

Controller Type:

MS4104, MS4109: Line voltage (120 Vac), two-position, SPST (Series 40).

MS4604, MS4609: Line voltage (230 Vac), two-position, SPST (Series 40).

MS8104, MS8109: Low voltage (24 Vac), two-position, SPST (Series 80).

Table 2. MS4104, MS4109, MS4604, MS4609, MS8104 and MS8109 DCA Models.

Model	Power Consumption		Torque in lb-in. (N•m)	Voltage Input in Vac
	Running	Holding		
MS4104F	0.18A, 18W	0.11A, 9W	30 (3.4)	120 ±10%, 50/60 Hz
MS4109F	0.25A, 23W	0.13A, 7W	80 (9)	
MS4604F	0.13A, 18W	0.10A, 11W	30 (3.4)	230 ±10%, 50/60 Hz
MS4609F	0.13A, 23W	0.09A, 7W	80 (9)	
MS8104F	16 VA	8 VA	30 (3.4)	24Vac/dc +20%, -10%, 50/60 Hz
MS8109F	23 VA	7 VA	80 (9)	

ORDERING INFORMATION

When purchasing replacement and modernization products from your TRADELINE® wholesaler or distributor, refer to the TRADELINE® Catalog or price sheets for complete ordering number. If you have additional questions, need further information, or would like to comment on our products or services, please write or phone:

1. Your local Honeywell Environmental and Combustion Controls Sales Office (check white pages of your phone directory).
2. Honeywell Customer Care
1985 Douglas Drive North
Minneapolis, Minnesota 55422-4386
3. <http://customer.honeywell.com> or <http://customer.honeywell.ca>

International Sales and Service Offices in all principal cities of the world. Manufacturing in Belgium, Canada, China, Czech Republic, Germany, Hungary, Italy, Mexico, Netherlands, United Kingdom, and United States.

Torque Rating (at rated voltage):

Spring Return:

MS4104F, MS4604F, MS8104F: 30 lb-in. (3.4 N•m).
 MS4109F, MS4609F, MS8109: 80 lb-in. (9 N•m).

Stall Maximum:

MS4104F, MS4604F, MS8104F: 150 lb-in. (17 N•m).
 MS4109F, MS4609F, MS8109: 240 lb-in. (27 N•m).

350°F Driving:

MS4104F, MS4604F, MS8104F: 30 lb-in. (3.4 N•m).
 MS4109F, MS4609F, MS8109: 80 lb-in. (9 N•m).

Timing (At Rated Torque and Voltage):

Drive Open: 15 seconds typical.
 Spring Close: 15 seconds typical.

Cycling Requirements:

The actuator and the internal spring are designed to require no special cycling during long-term holding.

Honeywell recommends following all local, state and national codes for periodic testing of the entire smoke control system. Refer to National Fire Protection Association (NFPA) National Fire Codes®: NFPA90A, NFPA92A and NFPA92B for your application.

NFPA recommends periodic examination of each fire/smoke damper (semi-annually or annually) to ensure proper performance.

Design Life (at Rated Voltage): 30,000 full stroke cycles.

Approvals: See Table 3.

Environmental Protection Ratings: See Table 4.

Accessories:

205649 Mounting Bracket (not supplied with actuator).

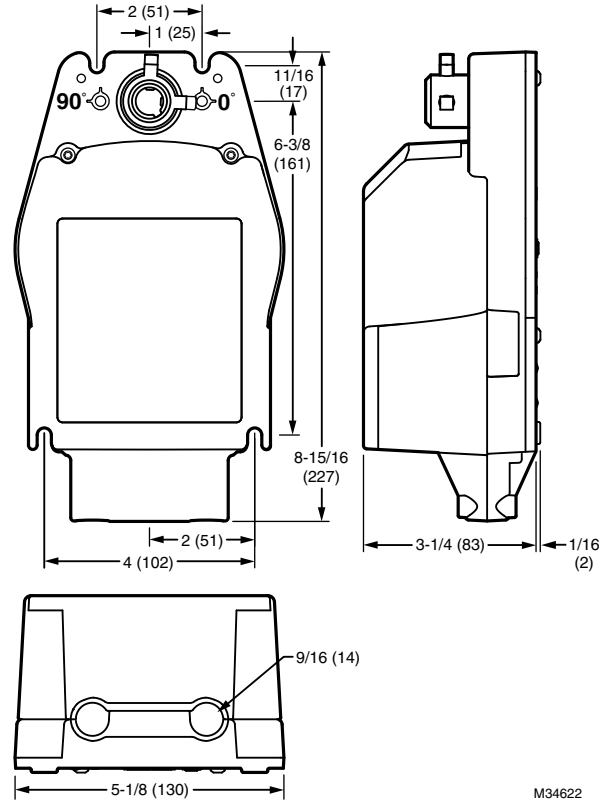

Fig. 1. MS4104, MS4109, MS4604, MS4609, MS8104 and MS8109 dimensional drawing in in. (mm).

Table 3. Approvals.

	MS4104F, MS4109F	MS4604F, MS4609F	MS8104F, MS8109F
UL/cUL	X	X	X
UL60730	X	X	X
CE	X	X	X
C-Tick	X	X	X

Table 4. Environmental Ratings.

All Devices	MS4104, MS4109, MS4604, MS4609, MS8104 and MS8109
NEMA1	IP40

INSTALLATION

When Installing this Product...

1. Read these instructions carefully. Failure to follow them could damage the product or cause a hazardous condition.
2. Check the ratings given in the instructions and on the product to make sure the product is suitable for your application.
3. Installer must be a trained, experienced service technician.
4. After installation is complete, check out product operation as provided in these instructions.

IMPORTANT

All wiring must agree with applicable codes, ordinances and regulations.

WARNING

Electrical Power Hazard.
Line voltage can cause death or serious injury and short equipment circuitry.
Disconnect power supply before installation.

CAUTION

Electrical Shock or Equipment Damage Hazard.
Low voltage can shock individuals or short equipment circuitry.
Disconnect power supply before installation.

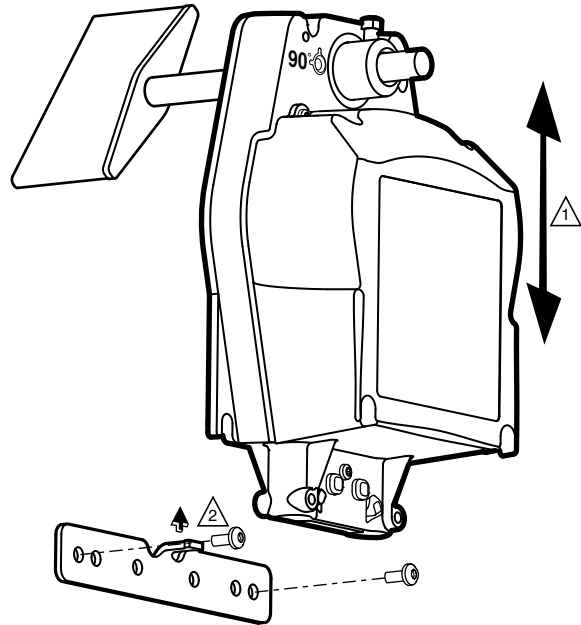

⚠️ ENSURE THAT MOUNTING ASSEMBLY PREVENTS ACTUATOR ROTATION AND ALLOWS ACTUATOR TO FLOAT ALONG INDICATED AXIS. WHEN TOO TIGHT, THE RESULTING BINDING CAN DAMAGE THE ACTUATOR OR REDUCE TORQUE OUTPUT.

⚠️ ACCESSORY MOUNTING BRACKET IS NOT SUPPLIED WITH THE ACTUATOR.

M34623

Fig. 2. Mounting actuator to damper housing.

Location and Mounting

The actuators are designed to open a damper by driving the damper shaft in either clockwise ↻ or counterclockwise ↻ direction. The actuator housing has two slots on the bottom that, with a 205649 Mounting Bracket, secure it flush to a damper box (see Fig. 2). When mounted correctly, these slots allow the actuator to *float* without rotating relative to the damper shaft.

CAUTION

Equipment Damage Hazard.
Tightly securing actuator to damper housing can damage actuator.
Mount actuator to allow it to float along its vertical axis.

Preparation

Before mounting the actuator onto the damper shaft, determine the:

- Damper/valve opening direction for correct spring return rotation. The actuator can be mounted to provide clockwise or counterclockwise spring return.
- Damper shaft size (see Specifications section).

Installation



CAUTION

Device Malfunction Hazard.

Improper set screw tightening causes device malfunction.

Ensure damper blade is in the correct position and tighten set screws with proper torque to prevent damper shaft slippage.



CAUTION

Actuator Damage Hazard.

Using actuator as shaft bearing causes device damage.

Use actuator only to supply rotational torque. Avoid any side loads to actuator output coupling bearings.

To install actuator, proceed as follows:

1. Place actuator over damper shaft; and hold mounting bracket in place. See Fig. 2.
2. Mark screw holes on damper housing.
3. Remove actuator and mounting bracket.
4. Drill or center-punch holes for mounting screws (or use no.10 self-tapping sheet metal screws).
5. Turn damper blades to desired normal (closed) position.
6. Place actuator and mounting bracket back into position and secure bracket to damper box with sheet metal screws.
7. Tighten set screws securely into damper shaft using minimum 100 lb-in., maximum 130 lb-in. torque. Use 1/4 in. wrench (see Specifications for details) to tighten set screws.

Wiring

See Fig. 3 through 5 for typical wiring diagrams.



WARNING

Electrical Power Hazard.

Line voltage can cause death or serious injury and short equipment circuitry.

Disconnect power supply before installation.



CAUTION

Electrical Shock or Equipment Damage Hazard. Low voltage can shock individuals or short equipment circuitry.

Disconnect power supply before installation.

IMPORTANT

1. All wiring must comply with local electrical codes, ordinances and regulations.
2. Voltage and frequency of transformer must correspond with the characteristics of power supply and actuator.
3. Use wires rated for at least 75°C (167°F).
4. The conduit fittings are designed for use with 3/8 in. reduced-wall steel or aluminum flexible conduit.

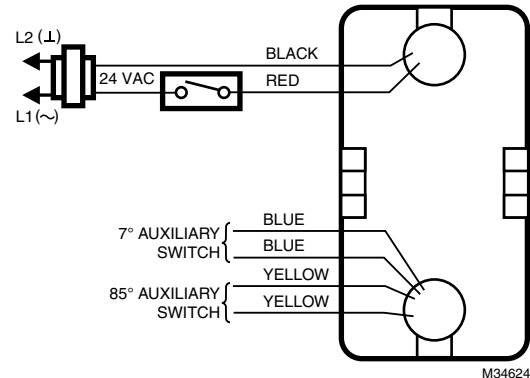

Fig. 3. Typical 24 Vac wiring.

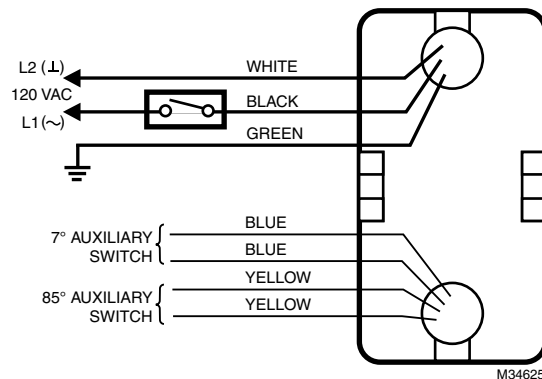

Fig. 4. Typical 120 Vac wiring.

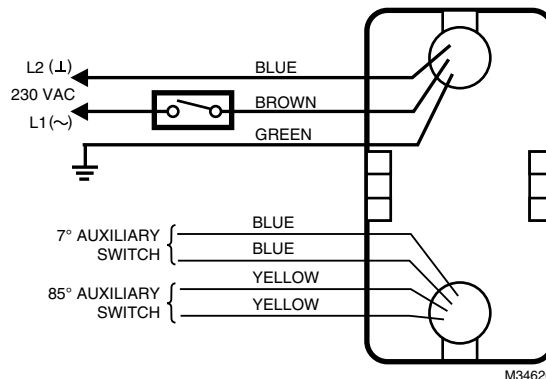

Fig. 5. Typical 230 Vac wiring.

OPERATION

The MS4104, MS4109, MS4604, MS4609, MS8104 and MS8109 DCA are designed for use in Smoke Control Systems. If power fails, the actuator spring returns to the 0° position. The actuator mounts flush with the damper box. The actuator drives from 0° to 95° and spring returns back to 0°.

The actuators are operated by an spst two-position controller. When using an spst two-position controller, the actuator drives to the damper fully open position when controller contact makes and spring returns to the damper fully closed position when controller contact breaks. The actuator drops to holding power level on detection of stall, independent of hub position.

Cycling

The actuator and the internal spring are designed so that no special cycling during long-term holding is required. Honeywell recommends following all local, state, and national codes for periodic testing of the entire smoke control system. Refer to National Fire Protection Association (NFPA) National Fire Codes®: NFPA90A, NFPA92A, and NFPA92B for your application.

NOTE: The actuator is designed to operate for 30 minutes during a one-time excursion to 350°F (176°C).

CHECKOUT

MS4104F, MS4109F (120 Vac model)

1. Check damper position.
2. Connect 120 Vac to the black and white leadwires to drive the damper to the open position. The actuator should drive the damper.
3. If the actuator does not spring return, verify that the actuator is properly installed. See Installation section.
4. If the actuator is correctly installed but neither runs nor spring returns, replace the actuator.

MS4604F, MS4609F (230 Vac model)

1. Check damper position.
2. Connect 230 Vac to the blue and brown leadwires to drive the damper to the open position. The actuator should drive the damper.
3. If the actuator does not spring return, verify that the actuator is properly installed. See Installation section.
4. If the actuator is correctly installed but neither runs nor spring returns, replace the actuator.

MS8104F, MS8109F (24 Vac model)

1. Check damper position.
2. Connect 24 Vac to the red and black leadwires to drive the damper to the open position. The actuator should drive the damper.
3. If the actuator does not spring return, verify that the actuator is properly installed. See Installation section.
4. If the actuator is correctly installed but neither runs nor spring returns, replace the actuator.

National Fire Codes® is a registered trademark of the National Fire Protection Association (NFPA).

Automation and Control Solutions

Honeywell International Inc.

1985 Douglas Drive North

Golden Valley, MN 55422

customer.honeywell.com

© U.S. Registered Trademark
© 2013 Honeywell International Inc.
63-2740—05 M.S. Rev. 12-13
Printed in United States

Honeywell



4-Wire Photoelectric Duct Smoke Detector

The InnovairFlex™ Series are the only duct smoke detectors flexible enough to fit configurations from square to rectangular and everything in between.

Features

- Photoelectric, integrated low-flow technology
- Air velocity rating from 100 ft/min to 4,000 ft/min (0.5 m/s to 20.32 m/sec)
- Versatile mounting options: square or rectangular configuration
- Plug-in sensor offers superb false alarm immunity and the latest sensor technology
- Broad ranges for operating temperature (–4°F to 158°F) and humidity (0% to 95% non-condensing)
- Patented sampling tube installs from front or back of the detector with no tools required
- Increased wiring space with a newly added 3/4-inch conduit knockout
- One easy-access Test/Reset button and improved LED status
- Patented interconnect feature for multi-fan shutdown
- New high contrast terminal designations
- Built-in short circuit protection from operator wiring errors
- Field selectable settings for configuring the detector
- Two DPDT Form-C relay contacts
- 24 VAC/DC or 120VAC
- Backward compatibility with existing Innovair products, including remote accessories

Agency Listings



Innovairflex™

The InnovairFlex D4120 4-wire photoelectric duct smoke detector features a pivoting housing that fits both square and rectangular footprints and mounts to round or rectangular ductwork. This unit senses smoke in the most challenging conditions, operating in airflow speeds of 100 to 4,000 feet per minute, temperatures of –4°F to 158°F, and a humidity range of 0 to 95 percent (non-condensing). A plug-in sensor head offers improved false alarm immunity and simple installation, testing, and maintenance. An improved cover design isolates the sensor head from the low-flow feature for simple maintenance.

The InnovairFlex housing provides ample wiring space, a 3/4-inch conduit knockout, and built-in short circuit protection to prevent damage to sensitive components during installation. High contrast terminal designations make wiring easy. With its 2:1 sensor-to-power capability, the power board of the D4120 may be used to monitor a second sensor, D4S, simultaneously (i.e., supply and return side). As many as 50 InnovairFlex detectors can be interconnected. When one unit senses smoke, all interconnected detectors will switch their relays; only the detector sensing smoke will go into alarm, thus pinpointing the fire source.

An easy-access Test/Reset button makes it possible to test the unit with the cover on. Three DIP switches can be used to configure field selectable settings: cover tamper delay, number of sensors to be controlled, and shut down on trouble option. Each power board has two LEDs that can be used to indicate the status of connected sensors, and a quick reference imprinted on the cover explains the LED status indications (Standby, Maintenance, Trouble, and Alarm). The InnovairFlex duct smoke detector can be customized to meet local codes and specifications without additional wiring. The new InnovairFlex product line is compatible with all previous Innovair models, including remote test accessories.

WARNING: Duct smoke detectors are **NOT** a substitute for open area smoke detectors; **NOT** a substitute for early warning detection; **NOT** a replacement for a building's regular fire detection system. Refer to NFPA 72 and 90A for additional information.

InnovairFlex™ Duct Smoke Detector Specifications

Architectural/Engineering Specifications

The air duct smoke detector shall be a System Sensor InnovairFlex™ D4120 Photoelectric Duct Smoke Detector. The detector housing shall be UL listed per UL 268A specifically for use in air handling systems. The flexible housing of the duct smoke detector fits multiple footprints from square to rectangular. The detector shall operate at air velocities of 100 feet per minute to 4000 feet per minute (0.5 to 20.32 meters/second). The unit shall be capable of controlling up to 50 air handling systems when interconnected with other detectors. The detector shall be capable of providing a trouble signal in the event that the front cover is removed. It shall be capable of local testing via magnetic switch, test button on the cover, or remote testing using the SSK451 Multi-Signaling Accessory or the RTS451KEY Remote Test Station. Terminal connections shall be of the strip and clamp method suitable for 12–18 AWG wiring.

Physical Specifications

Size: (Rectangular Dimensions)	14.38 in (37 cm) Length; 5 in (12.74 cm) Width; 2.5 in (6.36 cm) Depth
Size: (Square Dimensions)	7.75 in (19.7 cm) Length; 9 in (22.9 cm) Width; 2.5 in (6.35 cm) Depth
Weight:	2.5 lbs (1.14 kg)
Operating Temperature Range:	D4120 & D4S: -4° to 158°F (-20° to 70°C); D4P120: -40° to 158°F (-40° to 70°C)
Storage Temperature Range:	D4120 & D4S: -22° to 158°F (-30° to 70°C); D4P120: -40° to 158°F (-40° to 70°C)
Operating Humidity Range:	0% to 95% relative humidity non-condensing
Air Duct Velocity:	100 to 4000 ft/min (0.5 to 20.32 m/sec)

Electrical Ratings

Power supply voltage:	20–29 VDC	24 VAC 50–60 Hz	120 VAC 50–60 Hz
Input capacitance:	270 µF max.	270 µF max.	N/A
Reset voltage:	3.0 VDC min.	2.0 VAC min.	10 VAC min.
Reset time: (with RTS451)	.03 to 0.3 sec.	.03 to 0.3 sec.	.03 to 0.3 sec.
Reset time: (by power down)	0.6 sec. max.	0.6 sec. max.	0.6 sec. max.
Power up time:	35 sec. max.	35 sec. max.	35 sec. max.
Alarm response time:	15 sec.	15 sec.	15 sec.
Sensitivity Test:	See detector label	See detector label	See detector label

Current Requirements: (Using No Accessories)

Max. standby current:	21 mA @ 24VDC	65 mA RMS @ 24VAC 60Hz	20 mA RMS @ 120VAC 60Hz
Max. alarm current:	65 mA @ 24VDC	135 mA RMS @ 24VAC 60Hz	35 mA RMS @ 120VAC 60Hz

Contact Ratings

Alarm initiation contacts: (SPST)	2.0A @ 30 VDC (resistive)
Alarm auxiliary contacts: (DPDT)	10A @ 30 VDC (resistive); 10A @ 250 VAC (resistive); ½ HP @ 240 VAC ; ¼ HP @ 120 VAC
Note: Alarm auxiliary contacts shall not be connected to initiating circuits of control panels. Use the alarm initiation contact for this purpose.	
Supervisory contacts: (SPDT)	2.0A @ 30 VDC (resistive); 2.0A @ 125 VAC (resistive)

Accessory Current Loads at 24 VDC

Device	Standby	Trouble	Alarm
APA151/APA451	12.5 mA	n/a	30 mA Max.
MHR/MHW	0 mA	n/a	29 mA Max.
RA400Z	0 mA	n/a	12 mA Max.
RTS451/RTS451KEY	0 mA/12 mA	n/a	12 mA Max.
SSK451	8 mA Max.	16 mA Max.	40 mA Max.

Note: Any combination of accessories may be used such that the given accessory loads are: 110 mA or less at the Aux output, and 50 mA or less at the Alarm output

Installing the InnovairFlex Sampling Tube

The InnovairFlex sampling tube may be installed from the front or back of the detector. The tube locks securely into place and can be removed by releasing the front or rear locking tab (front locking tab shown below right).

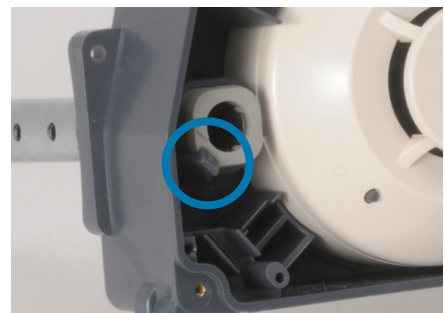

Wiring for 4-wire Duct Smoke Detector and Accessories

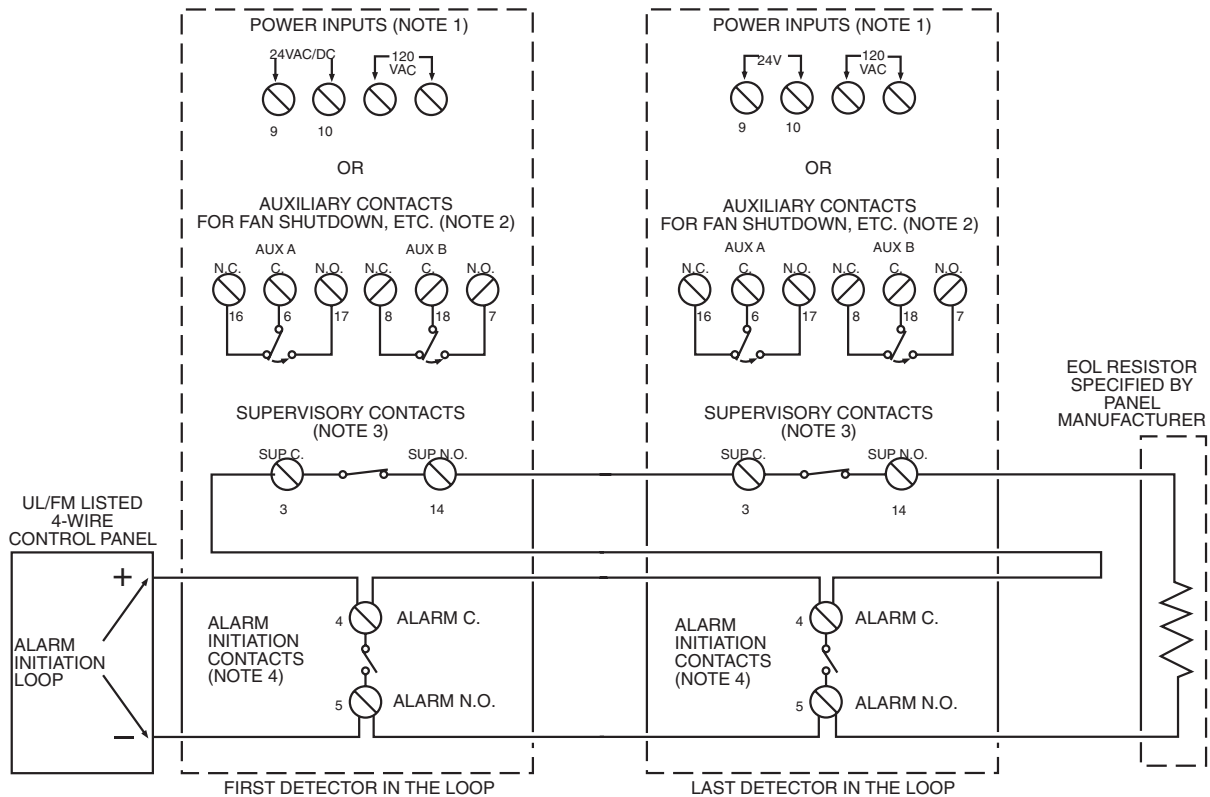

NOTE 1: 24V Power Inputs accept a non-polarized 24VDC or 24VAC 50-60Hz. 120VAC Power Inputs accept only 120VAC 50-60Hz. Connect power source to appropriate terminals of each detector. See specifications for additional power supply information.

NOTE 2: Auxiliary contacts shown in standby position. Contacts switch during alarm as indicated by arrows. Auxiliary contacts are not to be used for connection to the control panel. See specifications for contact ratings.

NOTE 3: Supervisory contacts shown in standby position. Open contacts indicate a trouble condition to the panel. See specifications for contact ratings.

NOTE 4: Alarm Initiation contacts shown in standby position. Closed contacts indicate an alarm condition to the panel. See specifications for contact ratings.

*Please refer to the corresponding installation manual for accessory wiring diagrams.

Important Notes on 2:1 Sensor-to-Power Capability

- 2:1 sensor-to-power capability is not available for all InnovairFlex models. The feature is only available on the D4120 4-wire conventional models.
- 2:1 sensor-to-power capability can be enabled using one D4120 and one D4S, or two D4S and one D4P120.

Important Interconnect Notes

- When using the interconnect feature, all interconnected units must be powered using the same independent supply.
 - Polarity must be maintained throughout the interconnect wiring. Connect the INT+ terminal on unit 1 to the INT+ terminal on unit 2 and so on. Similarly, connect the INT/AUX- terminal on unit 1 to the INT/AUX- terminal on unit 2 and so on.
 - Up to 50 D4120 units, 50 D4P120 units, or 50 units of combination may be interconnected.
 - Up to 10 DH100ACDC units may be interconnected. Please note that each of the 9 DH100ACDC units interconnected may be replaced by three D4P120 units. Therefore, when using the interconnect feature a single DH100ACDC can drive either 9 DH100ACDCs or 27 D4120 units.
- * NOTE: Alarm can be reset only at the initiating device and not at the devices interconnected.

Accessories

System Sensor provides system flexibility with a variety of accessories, including two remote test stations and several different means of visible and audible system annunciation. As with our duct smoke detectors, all duct smoke detector accessories are UL listed.



RTS451 UL S2522



RTS451KEY UL S2522



APA151 UL S4011



SSK451 UL S2522



RA400Z UL S2522



MHW UL S4011



MHR UL S4011



SSK451 with PS24LOW strobe and PS12/24 LENS lenses

Ordering Information

Part No.	Description		
D4120	4-wire photoelectric low-flow duct smoke detector		
Accessories			
D4S	4-wire photoelectric sensor component only	MHR	Mini Horn, Red
D4P120	4-wire photoelectric power board component only, 24 VAC/DC, 120 VAC	MHW	Mini Horn, White
2D51	4-wire conventional photoelectric sensor head	P48-21-00	End cap for metal sampling tubes
DST1	Metal sampling tube duct width up to 1ft (0.3m)	PS12/24LENSC	Ceiling-mount "SMOKE" lens
DST1.5	Metal sampling tube duct widths 1 ft to 2 ft (0.3 to 0.6 m)	PS12/24LENSW	Wall-mount "SMOKE" lens
DST3	Metal sampling tube duct widths 2 ft to 4 ft (0.6 to 1.2 m)	PS24LO	Mini-Alert add-on strobe (red)
DST5	Metal sampling tube duct widths 4 ft to 8 ft (1.2 to 2.4 m)	PS24LOW	Mini-Alert add-on strobe (white)
DST10	Metal sampling tube duct widths 8 ft to 12 ft (2.4 to 3.7 m)	RA400Z	Remote annunciator alarm LED
APA151	Remote annunciator with piezo alarm	RTS451	Remote test station
DH400 OE-1	Weatherproof enclosure	RTS451KEY	Remote test station with key lock
ETX	Metal exhaust tube duct width 1ft (0.3m)	SSK451	Multi-signaling accessory
M02-04-00	Test magnet		



3825 Ohio Avenue • St. Charles, IL 60174
Phone: 800-SENSOR2 • Fax: 630-377-6495

©2008 System Sensor.
Product specifications subject to change without notice. Visit systemsensor.com for current product information, including the latest version of this data sheet.
A05-0419-000 • 8/08 • #1836



**FACTORY MOUNTED DUCT SMOKE DETECTOR
LOW FLOW (100 TO 4000 FPM AIR VELOCITY)
FOR USE WITH 1200 SERIES SMOKE AND COMBINATION
FIRE/SMOKE DAMPERS
MODEL: DSD-LF**

QUALIFICATIONS:

The following qualifications apply to the smoke detector only. There is no separate UL product category for factory-mounted detector/damper combination. Refer to individual damper specification drawing for damper qualifications. Consult the local authority having jurisdiction before installation to ensure local code compliance.

- **UL 268A Listed Smoke-automatic Detectors, Category UROX (File # S911).**
- **Meets the requirements of NFPA 72, 90A, 92 and 101.**
- **City of New York. MEA No. 29-01-E.**
- **California State Fire Marshal Listing No. 7272-1653:0207.**
- **Factory Mutual Approved.**

APPLICATION:

Nailor model DSD-LF duct smoke detector (low-flow) can be utilized with Nailor UL 555S Classified smoke or combination fire/smoke dampers to detect the presence of smoke within HVAC ductwork and close the damper to prevent the smoke from spreading. As most fatalities resulting from fires can be attributed to the effects of toxic smoke, detecting and controlling the smoke from spreading within the HVAC system is vital to preventing injury as well as limiting property damage, including damage to the HVAC system itself. Refer to NFPA Standards 72, 90A and 92 to determine when and where duct smoke detectors are required.

The DSD-NF detector can be factory installed to side of sleeve on Nailor Model Series 1210, 1260, 1280, 1220 and 1270.

A minimum airflow velocity of 100 fpm (0.5 m/s) is required for Model DSD-LF.

OPERATION:

Upon detection of smoke, the smoke detector causes the damper to close by cutting off power to the actuator. The actuator return spring forces the damper closed. The detector can be reset only by a momentary power interruption. The standard model DSD-LF detector and smoke damper combination is designed simply to close the damper upon detection of smoke. For applications requiring the detector to be wired into a firefighters' smoke-control station (FSCS), contact Nailor.

DSD-LF STANDARD SPECIFICATION:

Model: System Sensor D4120.

Sensor Type: Photoelectric.

Dimensions: (Rectangular) 14.38" (365) Length, 5" (127) Width, 2.5" (64) Depth.

Weight: 2.5 lbs. (1.14 kg.).

Airflow Velocity Range: 100 to 4000 fpm (0.5 to 20.3 m/s).

Operating Temperature Range: -4°F to 158°F (-20°C to 70°C).

Operating Humidity Range: 0% to 95% Relative Humidity Non-Condensing.

Voltage: 24 VAC/DC or 120 VAC.

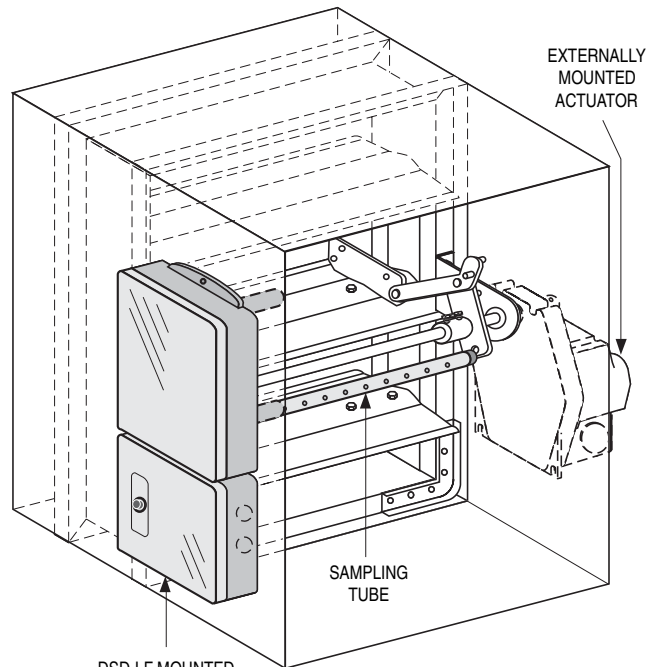

NOTES:

1. Smoke detector is factory mounted externally on left side of sleeve (opposite side of sleeve to the actuator) and will be mounted horizontally on dampers under 20" (508) in height and mounted vertically on dampers 20" (508) in height and over. See orientation details below.
2. Factory mounted smoke detectors will be factory wired to actuator(s) (or E.P. switch) and heat sensor(s), as applicable, into a 4" x 4" (102 x 102) common junction box in order to provide a single point wiring connection in the field.

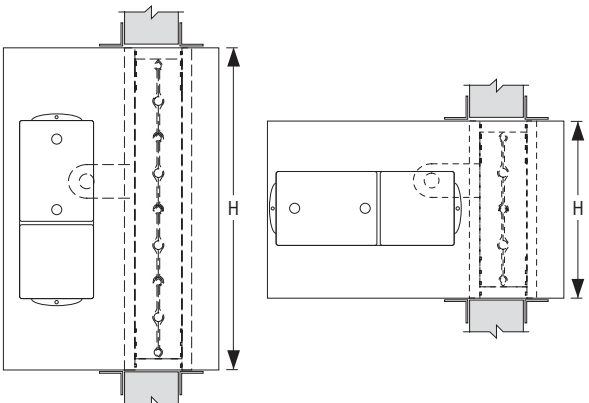

Height ≥ 20" (508)

Height < 20" (508)

Dimensions are in inches (mm).

SCHEDULE TYPE:				
PROJECT:				
ENGINEER:	DATE	B SERIES	SUPERSEDES	DRAWING NO.
CONTRACTOR:	9 - 4 - 13	1200	NEW	DSD-LF



**FACTORY MOUNTED DUCT SMOKE DETECTOR
NO FLOW (0 TO 3000 FPM AIR VELOCITY)
FOR USE WITH 1200 SERIES SMOKE AND COMBINATION
FIRE/SMOKE DAMPERS
MODEL: DSD-NF**

QUALIFICATIONS:

The following qualifications apply to the smoke detector only. There is no separate UL product category for factory-mounted detector/damper combination. Refer to individual damper specification drawing for damper qualifications. Consult the local authority having jurisdiction before installation to ensure local code compliance.

- UL 268A Listed Smoke-automatic Detectors, Category UROX (File # S911).
- Meets the requirements of NFPA 72, 90A, 92 and 101.
- City of New York. MEA No. 205-94-E.
- California State Fire Marshal Listing No. 7272-1653:0122.
- Factory Mutual Approved.

APPLICATION:

Nailor model DSD-NF duct smoke detector (no-flow) can be utilized with Nailor UL 555S Classified smoke or combination fire/smoke dampers to detect the presence of smoke within HVAC ductwork, whether or not there is airflow and close the damper to prevent the smoke from spreading. As most fatalities resulting from fires can be attributed to the effects of toxic smoke, detecting and controlling the smoke from spreading within the HVAC system is vital to preventing injury as well as limiting property damage, including damage to the HVAC system itself. Refer to NFPA Standards 72, 90A and 92 to determine when and where duct smoke detectors are required.

The DSD-NF detector features a low-profile design for optimum pressure drop and will operate with airflow in either direction. It can be factory installed to top of sleeve (side mounting optional) on Nailor Model Series 1210, 1260, 1280, 1220 and 1270.

OPERATION:

Upon detection of smoke, the smoke detector causes the damper to close by cutting off power to the actuator. The actuator return spring forces the damper closed. The detector can be reset only by a momentary power interruption. The standard model DSD-NF detector and smoke damper combination is designed simply to close the damper upon detection of smoke. For applications requiring the detector to be wired into a firefighters' smoke-control station (FSCS), contact Nailor.

DSD-NF STANDARD SPECIFICATION:

- Model:** System Sensor 2151 Low-Profile.
- Sensor Type:** Photoelectric.
- Dimensions:** 6.1" (155) dia. flanged base.
- Weight:** 3.6 oz. (104 g.).
- Airflow Velocity Range:** 0 to 3000 fpm (0 to 15.24 m/s).
- Operating Temperature Range:** 32°F to 120°F (0°C to 49°C).
- Operating Humidity Range:** 10% to 93% Relative Humidity Non-Condensing.
- Voltage:** 120 VAC or 24 VAC/DC.
- Latching Arm:** Reset by momentary power interruption.
- Contact Nailor for minimum damper size and sleeve length for your specific application.**

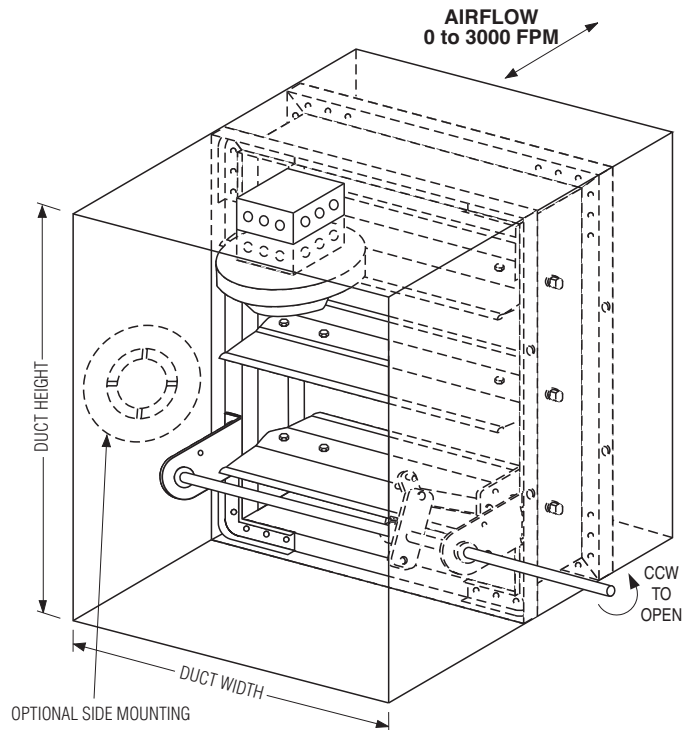

NOTES:

1. Factory mounted smoke detectors will be factory wired to actuator(s) (or E.P. switch) and heat sensor(s), as applicable, into a 4" x 4" (102 x 102) common junction box in order to provide a single point wiring connection in the field.

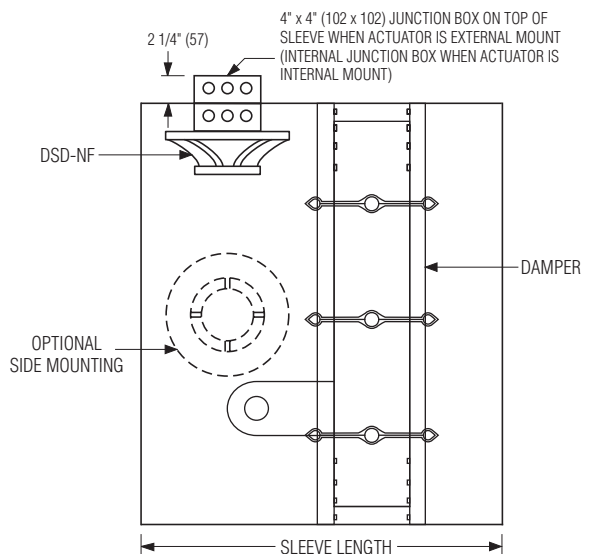

Dimensions are in inches (mm).

SCHEDULE TYPE:
PROJECT:
ENGINEER:
CONTRACTOR:

DATE	B SERIES	SUPERSEDES	DRAWING NO.
9 - 4 - 13	1200	1 - 5 - 09	DSD-NF



DUAL TEMPERATURE OVERRIDE SENSOR
REOPENABLE CONTROL SYSTEM WITH HIGH LIMIT
FOR COMBINATION FIRE / SMOKE DAMPERS
MODEL: DTO FIRE SENSOR

The DTO Dual Temperature Override Sensor is a factory installed option on Nailor combination fire/smoke dampers, incorporating two electric heat sensors (with external manual reset buttons). A primary heat sensor (manual reset) automatically closes the damper upon sensing an elevated temperature of 165°F (74°C) at the damper. The sensor interrupts power to the actuator, and the actuator's spring return mechanism causes the damper to close. The damper may be closed at anytime by placing a control switch (by others) in the closed position.

The primary heat sensor and the smoke detector (if used) can be bypassed by an external electrical signal from a remote control station, allowing the damper to reopen as may be required in the operation of a smoke control system. The Fire Fighter's Smoke-Control Station must include a three position (double throw, center off) master switch for correct operation.

The damper remains operational until the the temperature at the damper reaches that of the high limit secondary heat sensor. This is the UL listed elevated/degradation temperature rating (operational limit) of the damper/actuator assembly. The standard high limit temperature is 250°F (121°C). A 350°F (177°C) elevated temperature classification is available as an option. When the temperature of the high limit heat sensor is exceeded, the damper closes and locks and remains closed thereafter, in conformance with UL 555 and NFPA 90A. The secondary sensor can be manually reset, using the external button, at the damper after temperatures have cooled down.

The DTO can be ordered with electric (120 or 24 Vac) or pneumatic actuators. Pneumatic actuators are supplied with a factory mounted EP (electric/pneumatic) switch.

The DTO Fire Sensor also incorporates a position indicator package. Two auxiliary switches indicate the open and closed damper position at a remote control station.

For installation and operation instructions, see dwg. IOM-DTO.

NOTE:

Nailor recommends the use of a single ERL Electric Resettable Link at the elevated/degradation temperature of the damper/actuator assembly on all combination fire/smoke dampers. 250°F Standard (350°F optional). Together with a position indicator package (MLS-300) where remote damper position status is required.

The re-openable system only provides a narrow temperature window of operation, increased cost and complexity of operation, since UL555 introduced the high limit closure requirement in 1995 in full compliance with the intent of NFPA 90A.

Previous building codes used to require 165°F (74°C) for all fire dampers. This is no longer the case for Smoke Management Systems.

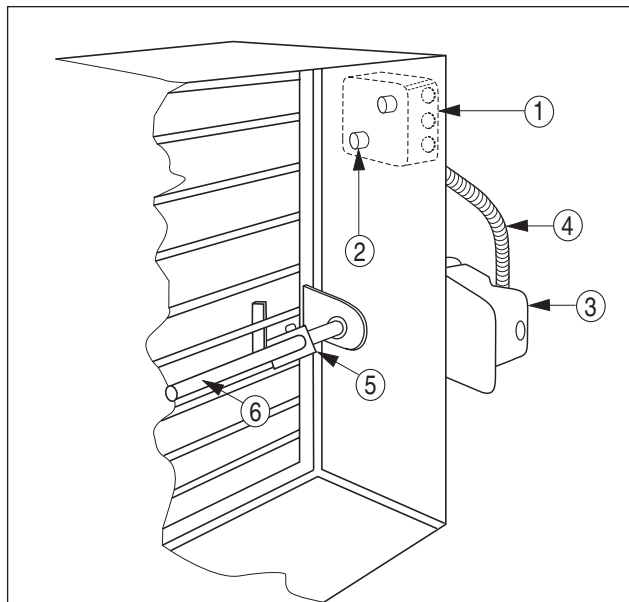

With UL Listed Electric Actuator
Description:

1. Electrical Junction Box with 165°F (74°C) Primary Heat Sensor
2. High Limit Secondary Heat Sensor 250°F or 350°F (121°C or 177°C)
3. Electric Actuator with Auxiliary Position Indicator Switches
4. Flexible Conduit
5. Over-Center Knee Lock
6. Jackshaft

SCHEDULE TYPE:		Page 1 of 2			
PROJECT:		Dimensions are in inches (mm)			
ENGINEER:	DATE	B SERIES	SUPERSEDES	DRAWING NO.	
CONTRACTOR:	9 - 8 - 20	FD-ACC	MLS-400/7-20-19	DTO	

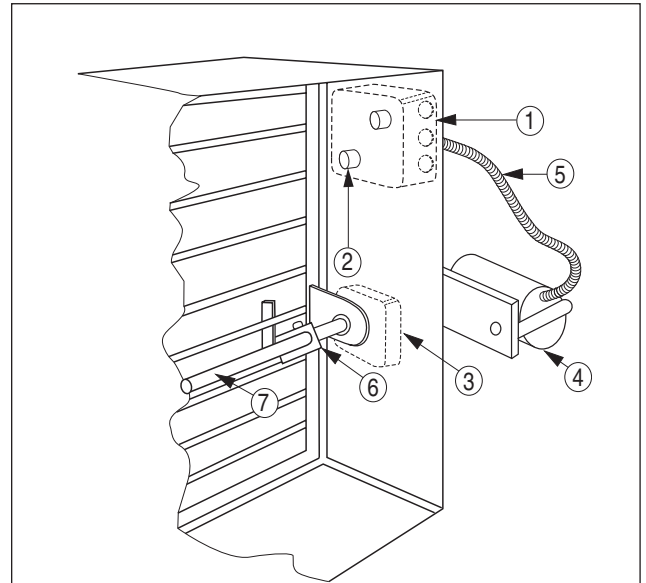

With UL Listed Pneumatic Actuator
Description:

1. Electrical Junction Box with 165°F (74°C) Primary Heat Sensor and EP Switch
2. High Limit Secondary Heat Sensor 250°F or 350°F (121°C or 177°C)
3. Position Indicator Package
4. Pneumatic Actuator
5. Silicone Tubing
6. Over-Center Knee Lock
7. Jackshaft

SCHEDULE TYPE:
PROJECT:
ENGINEER:
CONTRACTOR:

Page 2 of 2
Dimensions are in inches (mm)

DATE	B SERIES	SUPERSEDES	DRAWING NO.
9 - 8 - 20	FD-ACC	MLS-400/7-20-19	DTO



POSITION INDICATOR PACKAGE

FOR COMBINATION FIRE / SMOKE, SMOKE AND CONTROL DAMPERS

MODEL: MLS-300. For use with GGD221/121 (electric) and 331-2961 / 3060 (pneumatic) actuators

APPLICATION:

- The MLS-300 Position Indicator Package operates as a function of the damper blade position and provides the ability to remotely indicate damper blade position.
- The MLS-300 incorporates two SPDT switches and provides a positive open or closed signal when used in conjunction with remote indicator lights. MLS-300's are used in active smoke control management systems to positively indicate the status of all combination fire/smoke and smoke dampers in the building.
- The MLS-300 is available only as a factory installed option on combination fire/smoke and smoke dampers.
- The MLS-300 may also be used to provide a stop/start circuit for remote fans or to signal alarms.

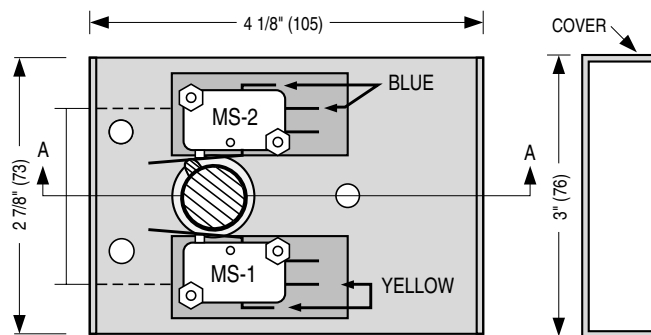

EXTERNAL RIGHT HAND MOUNTING: FRONT VIEW (LESS COVER)

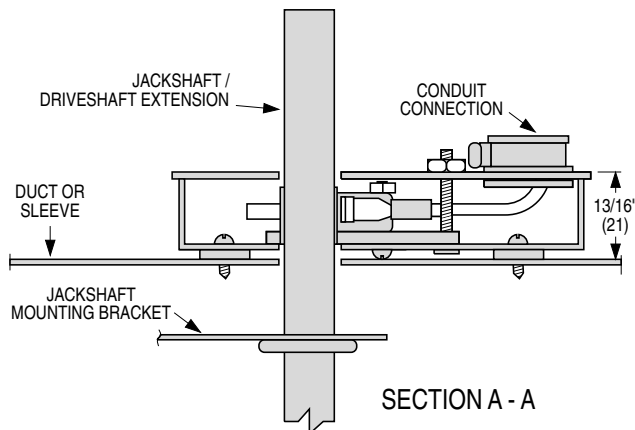

Position Indicator Microswitch Data:

Switch Type: Single Pole double throw (2)
 15 Amps, 1/3 HP, 125, 250 Vac or 24 Vdc.
 1/2 Amp, 125 Vdc. 1/4 Amp, 250 Vdc.

Standard Mounting:

MS1 is damper open signal.

MS2 is damper closed signal.

Non-Standard Mounting:

Important: Installer must double check continuity of MS1 and MS2 before wiring to determine which switch signals the damper's open or closed position.

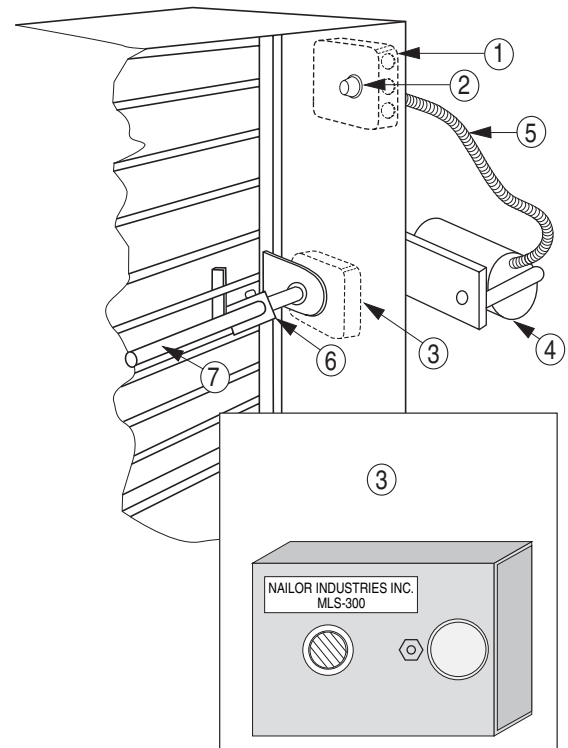

Typical Combination Fire / Smoke Damper Installation With UL Listed Actuator

Description:

1. Electrical Junction Box (and EP switch with pneumatic actuator[s])
2. ERL 165, 212, 250, 350°F Electric Resettable Link (Heat Sensor)
3. Position indicator package
4. Actuator (pneumatic illustrated).
5. Silicone Tubing or Flexible Conduit
6. Over-Center Knee Lock
7. Jackshaft

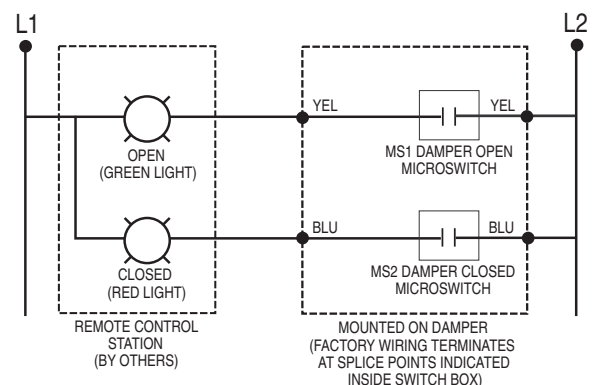

Dimensions are in inches (mm).

SCHEDULE TYPE:				
PROJECT:				
ENGINEER:	DATE	B SERIES	SUPERSEDES	DRAWING NO.
CONTRACTOR:	7 - 20 - 07	FD - ACC	12 - 4 - 02	MLS-300-2



POSITION INDICATOR PACKAGE

FOR COMBINATION FIRE/SMOKE AND SMOKE DAMPERS
FOR USE WITH BELIMO AND HONEYWELL ACTUATORS

MODEL: MLS-300

APPLICATION:

When ordered with the MLS-300 Position Indicator Switch Pack, Nailor combination fire/smoke and smoke dampers that utilize factory installed Belimo or Honeywell fire/smoke actuators will be supplied as standard with an actuator that has an integral internal mounted switch pack. The auxiliary switches provide an on/off signal at two points in the actuator stroke and this signal can be routed to a Fire Fighter’s Smoke Control Station for remote open/closed damper position status in Smoke Control Management Applications. Alternatively, they may be field wired to a local accessible damper control panel (Nailor DCP16). Both provide a means to cycle test the damper as part of a scheduled building maintenance program.

ELECTRICAL SWITCH RATINGS:

Honeywell:

Models MS4104F1210, MS4109F1210, MS4604F1210, MS4609F1210:

Ratings (maximum load): 120 VAC/24 VDC, 3A resistive
Settings (fixed): 7° nominal stroke, 85° nominal stroke

Model MS8104F1210, MS8109F1210:

Ratings (maximum load): 24 VAC/DC, 3A resistive
Settings (fixed): 7° nominal stroke, 85° nominal stroke

Model MS4120F1204, MS4620F1203, MS8120F1200:

Ratings (maximum load): 250 VAC, 5A resistive
Settings (fixed): 7° nominal stroke, 85° nominal stroke

Belimo:

Model FSTF120-S, FSTF24-S, FSTF230-S:

2 x SPST 3A resistive, 0.5A inductive @ 120 VAC,
Settings (fixed): One switch at 10°, one switch at 80°

Models FSLF24-S, FSLF120-S, FSLF230-S:

2 x SPST 3A resistive, 0.5A inductive @ 120/250 VAC,
1mA @ 5 VDC,
Settings (fixed): One switch at 10°, one switch at 85°

Models FSNF24-S, FSNF120-S, FSNF230-S:

2 x SPDT 7A resistive, 2.5A inductive @ 120/250 VAC,
Settings (fixed): One switch at 10°, one at 85°

Model FSAFA24-S, FSAFA120-S, FSAF230A-S:

2 x SPST 6A resistive, 2.5A inductive @ 120/250 VAC,
Settings (fixed): One switch fixed at 10°, one at 85°

Model FSAFB24-SR-S:

2 x SPST 3A resistive, 0.5A inductive @ 120/250 VAC,
Settings: One switch set at + 10°, one adjustable from 10° to 90°



Fig. 1 - Typical Honeywell Fire/Smoke Actuator with auxiliary switches (MLS-300)



Fig. 2 - Typical Belimo Fire/Smoke Actuator with auxiliary switches (MLS-300)

Refer to manufacturer’s submittal and installation and operating manual for complete details and wiring diagrams.

SCHEDULE TYPE:				
PROJECT:				
ENGINEER:	DATE	B SERIES	SUPERSEDES	DRAWING NO.
CONTRACTOR:	12 - 29 - 17	FD - ACC	4 - 28 - 14	MLS-300-3