

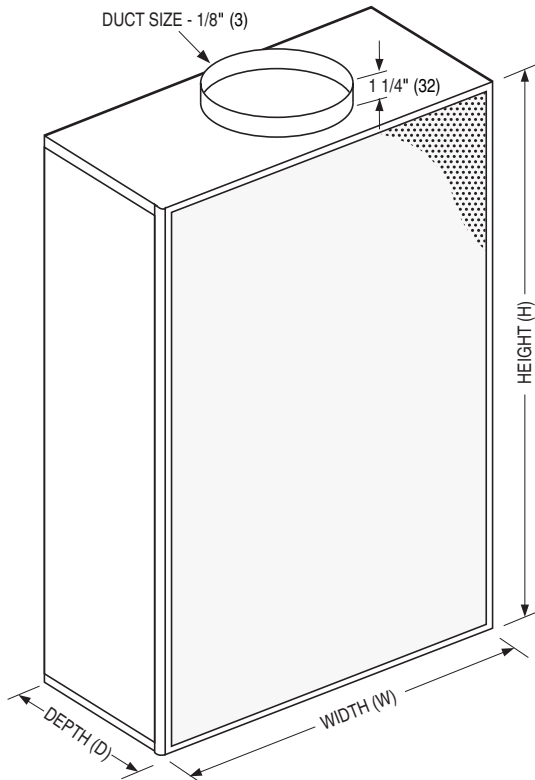

**RECTANGULAR 1-WAY DISPLACEMENT DIFFUSER
FLOOR STANDING • FLAT FACE • WALL/PILLAR
STEEL PERFORATED FACE
MODEL: DFF1**

Model DFF1 • 1-Way Discharge Air Pattern

Dimensional Data:



Unit Size (W x H)	Depth (D)	Inlet Size
24 x 24 (610 x 610) 24 x 36 (610 x 914)	13 (330)	8 (203), 10 (254), 14 x 6 (356 x 152)
24 x 48 (610 x 1219) 24 x 60 (610 x 1524)	13 (330)	8 (203), 10 (254), 14 x 6 (356 x 152), 16 x 8 (406 x 203)
36 x 24 (914 x 610)	13 (330)	8 (203), 10 (254), 14 x 6 (356 x 152)
	16 (406)	10 (254), 16 x 8 (406 x 203)
36 x 36 (914 x 914)	13 (330)	8 (203), 10 (254), 14 x 6 (356 x 152)
	16 (406)	10 (254), 16 x 8 (406 x 203)
36 x 48 (914 x 1219)	13 (330)	10 (254), 16 x 8 (406 x 203)
	16 (406)	10 (254), 12 (305), 18 x 8 (457 x 203)
36 x 60 (914 x 1524)	13 (330)	10 (254), 16 x 8 (406 x 203)
	16 (406)	10 (254), 12 (305), 16 x 8 (406 x 203), 18 x 8 (457 x 203)
48 x 24 (1219 x 610)	13 (330)	8 (203), 10 (254), 14 x 6 (356 x 152)
	16 (406)	10 (254), 14 x 6 (356 x 152), 16 x 8 (406 x 203)
48 x 36 (1219 x 914) 48 x 48 (1219 x 1219) 48 x 60 (1219 x 1524)	13 (330)	10 (254), 14 x 6 (356 x 152)
	16 (406)	10 (254), 12 (305), 16 x 8 (406 x 203), 18 x 8 (457 x 203)
		13 (330)
60 x 24 (1524 x 610)	16 (406)	10 (254), 12 (305), 16 x 8 (406 x 203), 18 x 8 (457 x 203)
	13 (330)	10 (254), 16 x 8 (406 x 203)
60 x 36 (1524 x 914)	16 (406)	10 (254), 12 (305), 16 x 8 (406 x 203), 18 x 8 (457 x 203)
	13 (330)	10 (254), 16 x 8 (406 x 203)
		16 (406)
60 x 48 (1524 x 1219)	13 (330)	10 (254), 16 x 8 (406 x 203)
	16 (406)	10 (254), 12 (305), 16 x 8 (406 x 203), 18 x 8 (457 x 203)

DESCRIPTION:

- Construction: Heavy gauge corrosion-resistant coated steel. Standard 18 ga.(1.3) perforated face has 3/32" (2) dia. holes on 3/16" (5) staggered centers, providing 23% free area.
- An equalization baffle is provided behind the diffuser face to ensure an even distribution of low velocity supply air.
- Floor mounted displacement diffusers are especially designed to supply air at a very low velocity to minimize the potential for drafts and enhance occupant comfort.
- Standard finish is AW Appliance White.

OPTIONS:

- Construction:
 - 16GP Heavy Duty 16 ga. (1.6) Perforated Face
- Inlet Type:
 - REC Rectangular
 - RND Round
 - FC Field Cut
- Inlet Location:
 - T Top
 - B Bottom
 - R Rear
 - LS Left Side
 - RS Right Side

4. Finish:

- AW Appliance White (default)
- AL Aluminum
- BK Black
- BW British White
- SP Special _____

5. Diffuser Base:

- DB02 2" (51) High
- DB03 3" (76) High
- DB04 4" (102) High
- DB05 5" (127) High
- DB06 6" (152) High

6. Duct Cover:

- DCP Perforated Panels
- DCS Solid Panels

7. Volume Control:

- BD Balancing Damper
- FMSD Flow Measuring Station with balancing damper (Round inlet sizes only). See separate submittal.

8. Protective Film:

- PFC Protective Film Cover on Face and Inlet

SCHEDULE TYPE:

PROJECT:

ENGINEER:

CONTRACTOR:

Dimensions are in inches (mm).

DATE	B SERIES	SUPERSEDES	DRAWING NO.
1 - 3 - 20	DFF	9 - 6 - 17	DFF1



**RECTANGULAR 1-WAY DISPLACEMENT DIFFUSER
FLOOR STANDING • FLAT FACE • CORNER
STEEL PERFORATED FACE
MODEL: DFF1C**

Model DFF1C • 1-Way Discharge Air Pattern

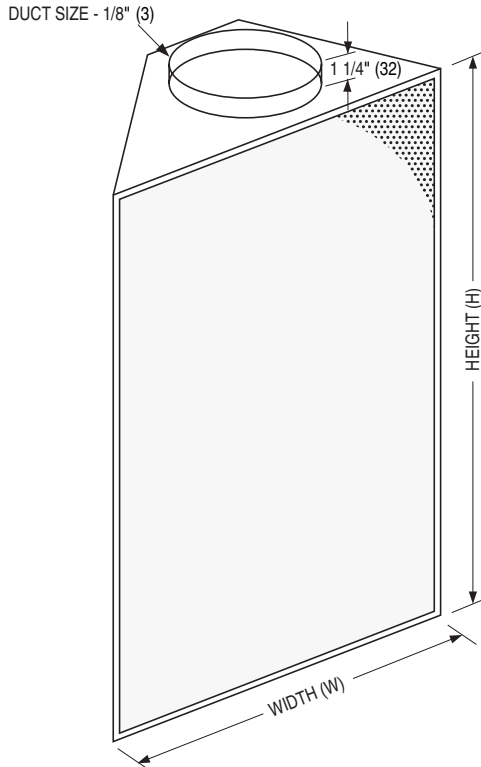

Dimensional Data:

Unit Size (W x H)	Duct Size
24 x 24 (610 x 610) 24 x 36 (610 x 914) 24 x 48 (610 x 1219) 24 x 60 (610 x 1524) 24 x 72 (610 x 1829)	8 (203)
30 x 24 (762 x 610) 30 x 36 (762 x 914) 30 x 48 (762 x 1219) 30 x 60 (762 x 1524) 30 x 72 (762 x 1829)	8 (203), 10 (254)
36 x 24 (914 x 610) 36 x 36 (914 x 914) 36 x 48 (914 x 1219) 36 x 60 (914 x 1524) 36 x 72 (914 x 1829)	8 (203), 10 (254), 12 (305)

DESCRIPTION:

1. Construction: Heavy gauge corrosion-resistant coated steel. Standard 18 ga. (1.3) perforated face has 3/32" (2) dia. holes on 3/16" (5) staggered centers, providing 23% free area.
2. An equalization baffle is provided behind the diffuser face to ensure an even distribution of low velocity supply air.
3. Floor mounted displacement diffusers are especially designed to supply air at a very low velocity to minimize the potential for drafts and enhance occupant comfort.
4. Standard finish is AW Appliance White.

OPTIONS:

1. Construction:
 - 16GP Heavy Duty 16 ga. (1.6) Perforated Face
2. Inlet Type:
 - RND Round
 - FC Field Cut
3. Inlet Location:
 - T Top
 - B Bottom

4. Finish:
 - AW Appliance White (default)
 - AL Aluminum
 - BK Black
 - BW British White
 - SP Special _____
5. Diffuser Base:
 - DB02 2" (51) High
 - DB03 3" (76) High
 - DB04 4" (102) High
 - DB05 5" (127) High
 - DB06 6" (152) High
6. Duct Cover:
 - DCP Perforated Panels
 - DCS Solid Panels
7. Volume Control:
 - BD Balancing Damper
 - FMSS Flow Measuring Station with balancing damper (Round inlet sizes only). See separate submittal.
8. Protective Film:
 - PFC Protective Film Cover on Face and Inlet

SCHEDULE TYPE:	Dimensions are in inches (mm).			
PROJECT:				
ENGINEER:	DATE	B SERIES	SUPERSEDES	DRAWING NO.
CONTRACTOR:	2 - 25 - 20	DFF	1 - 8 - 20	DFF1C



**RECTANGULAR 3-WAY DISPLACEMENT DIFFUSER
FLOOR STANDING • FLAT FACE • WALL/PILLAR
STEEL PERFORATED FACE
MODEL: DFF3**

Model DFF3 • 3-Way Discharge Air Pattern

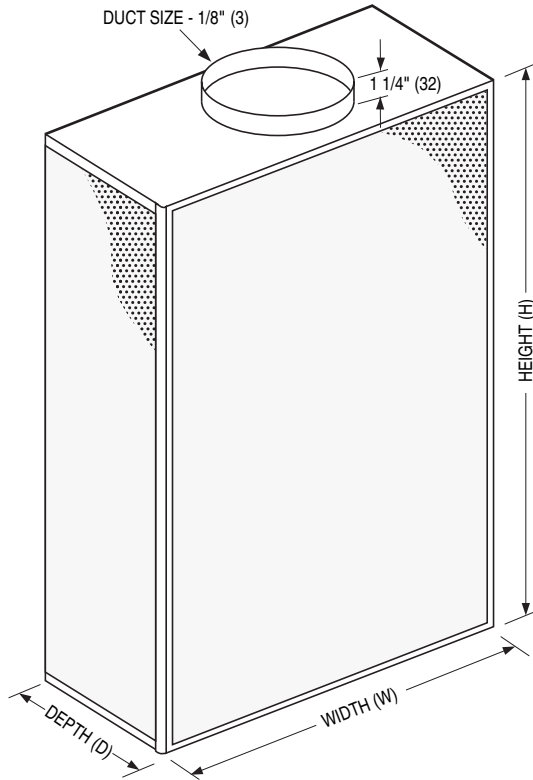

Dimensional Data:

Unit Size (W x H)	Depth (D)	Inlet Size
24 x 24 (610 x 610) 24 x 36 (610 x 914)	13 (330)	8 (203), 10 (254), 14 x 6 (356 x 152)
24 x 48 (610 x 1219) 24 x 60 (610 x 1524)	13 (330)	8 (203), 10 (254), 14 x 6 (356 x 152), 16 x 8 (406 x 203)
36 x 24 (914 x 610)	13 (330)	8 (203), 10 (254), 14 x 6 (356 x 152)
	16 (406)	10 (254), 16 x 8 (406 x 203)
36 x 36 (914 x 914)	13 (330)	8 (203), 10 (254), 14 x 6 (356 x 152)
	16 (406)	10 (254), 16 x 8 (406 x 203)
36 x 48 (914 x 1219)	13 (330)	10 (254), 16 x 8 (406 x 203)
	16 (406)	10 (254), 12 (305), 18 x 8 (457 x 203)
36 x 60 (914 x 1524)	13 (330)	10 (254), 16 x 8 (406 x 203)
	16 (406)	10 (254), 12 (305), 16 x 8 (406 x 203), 18 x 8 (457 x 203), 24 x 8 (610 x 203)
48 x 24 (1219 x 610)	13 (330)	8 (203), 10 (254), 14 x 6 (356 x 152)
	16 (406)	10 (254), 14 x 6 (356 x 152), 16 x 8 (406 x 203)
48 x 36 (1219 x 914) 48 x 48 (1219 x 1219)	13 (330)	10 (254), 14 x 6 (356 x 152)
	16 (406)	10 (254), 12 (305), 16 x 8 (406 x 203), 18 x 8 (457 x 203)
48 x 60 (1219 x 1524)	13 (330)	10 (254), 14 x 6 (356 x 152)
	16 (406)	10 (254), 12 (305), 14 (356), 16 x 8 (406 x 203), 18 x 8 (457 x 203), 20 x 10 (508 x 254)
	17 (432)	10 (254)
60 x 24 (1524 x 610)	13 (330)	8 (203), 10 (254), 16 x 8 (406 x 203)
	16 (406)	10 (254), 12 (305), 14 x 6 (356 x 152), 16 x 8 (406 x 203), 18 x 8 (457 x 203)
60 x 36 (1524 x 914) 60 x 48 (1524 x 1219)	13 (330)	10 (254), 16 x 8 (406 x 203)
	16 (406)	10 (254), 12 (305), 16 x 8 (406 x 203), 18 x 8 (457 x 203), 20 x 10 (508 x 254)
	17 (432)	14 (356)

DESCRIPTION:

- Construction: Heavy gauge corrosion-resistant coated steel. Standard 18 ga. (1.3) perforated face has 3/32" (2) dia. holes on 3/16" (5) staggered centers, providing 23% free area.
- An equalization baffle is provided behind the diffuser face to ensure an even distribution of low velocity supply air.
- Floor mounted displacement diffusers are especially designed to supply air at a very low velocity to minimize the potential for drafts and enhance occupant comfort.
- Standard finish is AW Appliance White.

OPTIONS:

- Construction:
 - 16GP Heavy Duty 16 ga. (1.6) Perforated Face
- Inlet Type:
 - REC Rectangular
 - RND Round
 - FC Field Cut
- Inlet Location:
 - T Top
 - B Bottom
 - R Rear
 - LS Left Side
 - RS Right Side

- Finish:
 - AW Appliance White (default)
 - AL Aluminum
 - BK Black
 - BW British White
 - SP Special _____
- Diffuser Base:
 - DB02 2" (51) High
 - DB03 3" (76) High
 - DB04 4" (102) High
 - DB05 5" (127) High
 - DB06 6" (152) High
- Duct Cover:
 - DCP Perforated Panels
 - DCS Solid Panels
- Volume Control:
 - BD Balancing Damper
 - FMSD Flow Measuring Station with balancing damper (Round inlet sizes only). See separate submittal.
- Protective Film:
 - PFC Protective Film Cover on Face and Inlet

SCHEDULE TYPE:

PROJECT:

ENGINEER:

CONTRACTOR:

Dimensions are in inches (mm).

DATE

B SERIES

SUPERSEDES

DRAWING NO.

2 - 25 - 20

DFF

1 - 15 - 20

DFF3



**FLOW MEASURING STATION
WITH BALANCING DAMPER
MODEL: 36FMSD**

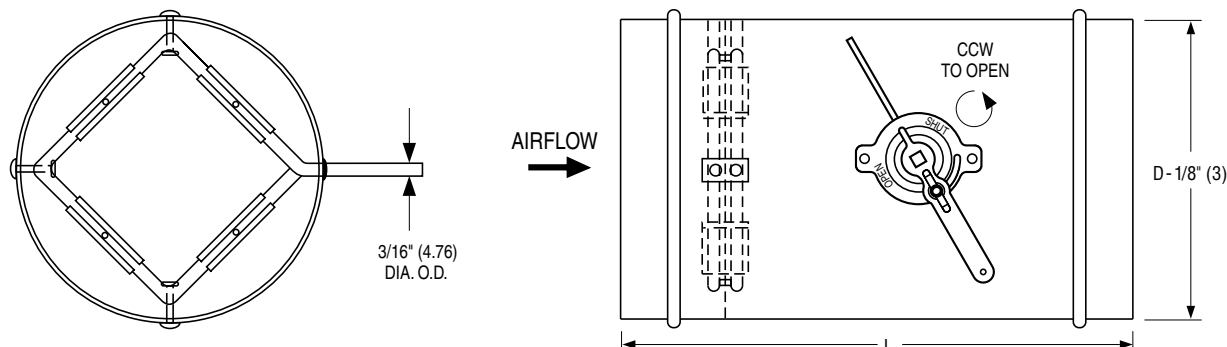

Description:

The Model 36FMSD Flow Measuring Station is a multi-point averaging airflow sensor combined with integral balancing damper. The 36FMSD allows the field balancer to measure and adjust the airflow to a diffuser or other air terminal device located downstream.

The 36FMSD is an especially useful option for balancing individual displacement ventilation diffusers.

A chart is provided on the unit which gives airflow vs. signal differential pressure for direct reading of airflow.

Features:

- 22 ga. (0.86), corrosion-resistant steel casing with stiffening beads and corrosion-resistant steel blade up to 12" (305) dia., 20 ga. (1.00) over 12" (305) dia.
- Sized to fit nominal round duct sizes.
- Inlet and outlet stiffening beads provide a means for secure flexible duct connection.
- Balancing damper with hand locking quadrant.
- Multi-point averaging Diamond Flow Sensor: Aluminum construction.
- Sensor design minimizes pressure drop and regenerated noise.

Dimensional Data

Unit Size	Airflow Range cfm (l/s)	Duct Size D	Length L
4	0 – 225 (0 – 106)	4 (102)	13 (330)
5	0 – 400 (0 – 189)	5 (127)	13 (330)
6	0 – 550 (0 – 260)	6 (152)	13 (330)
7	0 – 800 (0 – 378)	7 (178)	13 (330)
8	0 – 1100 (0 – 519)	8 (203)	13 (330)
9	0 – 1400 (0 – 661)	9 (229)	13 (330)
10	0 – 1840 (0 – 868)	10 (254)	13 (330)
12	0 – 2500 (0 – 1180)	12 (305)	13 (330)
14	0 – 3125 (0 – 1475)	14 (356)	15 (381)
16	0 – 3725 (0 – 1758)	16 (406)	15 (381)
18	0 – 5880 (0 – 2775)	18 (457)	16 (406)

SCHEDULE TYPE:		Dimensions are in inches (mm)			
PROJECT:					
ENGINEER:	DATE	B SERIES	SUPERSEDES	DRAWING NO.	
CONTRACTOR:	3 - 24 - 17	3600	4 - 10 - 14	36FMSD	



Nailor[®]
Industries Inc.

STANDARD AND OPTIONAL FINISHES FOR GRILLES AND DIFFUSERS

Nailor offers a selection of standard colors and finishes available on our grilles, registers and diffusers. For painted finishes, our state-of-the-art paint systems provide environmentally friendly finishing solutions with uniform coverage and coating thickness. The result is an exceptionally durable finish that resists scratching, corrosion and general wear. Additional facilities for special requirements, as well as a selection of anodized or brushed finishes, complete our ability to provide unmatched beauty and durability for any application.

NAILOR POWDER COAT PROPERTIES

FILM THICKNESS	2.0 to 3.0 mils
HARDNESS	2 H
IMPACT RESISTANCE	Direct: 160 inch - lbs. Reverse 160 inch - lbs.
SALT SPRAY	1000 hours

ELECTROCOATING PROPERTIES

FILM THICKNESS	.8 to 1.2 mils
HARDNESS	HB TO H
IMPACT RESISTANCE	80 inch - lbs
SALT SPRAY	100 hours



POWDER COAT

Nailor's powder coat is a high-tech thermosetting polyester powder coating with superior physical properties that provide excellent color and gloss retention. The finish offers extreme durability and hardness that resists scratching, chipping and general wear. Surface preparation includes degreasing and a chemical cleaning followed by a clean rinse before a final powder coat finish is applied and baked. The environmentally friendly Nailor powder coat system assures uniform coverage and color consistency resulting in a long lasting superior finish. Colors, including simulated anodizing, which is far more economical than color anodizing, can be selected from Nailor's standard color chart or non-standard colors and can be matched from sample chips provided to Nailor.

ELECTROCOATING

E-Coat is an environmentally friendly coating that provides complete coverage and a wide range of performance properties, formulated to meet corrosion, durability and other performance specifications. Electrocoating is a highly automated process in which paint is electrically deposited onto a metal foundation. Film build thickness is uniform and overall application efficiencies are in excess of 90%. Paint is consistent on all part-to-part surfaces, preventing sags, runs or drips. E-Coat offers flexibility, better first yield pass and quicker production times compared to other forms of paint applications. Electrocoating is an excellent solution that offers superior properties and uniform finish.

CLEAR ANODIZING (Aluminum products only)

Clear anodizing is a clear oxide coating that exemplifies an aluminum surface's natural oxide coating producing a hard, scratch resistant surface that is resistant to general wear and mild chemicals. The process provides a natural looking, virtually maintenance free finish that will endure for many years.

COLOR ANODIZING (Aluminum products only)

Color anodizing is an electrolytic process where, after standard anodizing procedures, colored metallic pigments penetrate the oxide surface pores producing a corrosion resistant, colorfast finish. The process results in a natural metallic appearance that requires little maintenance.

BRUSHED AND CLEAR COAT

Available on specific aluminum products (consult applicable product page for availability). Surface is brushed to achieve a scratch finish texture before being degreased and chemically cleaned. A clear lacquer coating is then applied to provide a durable protective finish.

#4 BRUSHED SATIN POLISHED (Stainless Steel products only)

Surface is polished to ASTM A480 #4 standard to achieve a bright durable finish that is resistant to mild chemicals and corrosion. A final coating is not required due to the inherent anti-corrosion properties of the stainless steel.

PRIME COAT

Prime coat provides a stable base for painting in the field. Surface pretreatment includes degreasing and a chemical cleaning before an alkyd prime coat is applied. After a thorough cleaning for dust, etc. that can contaminate the final finish and cause premature flaking or peeling, finish coat should be field applied as soon as possible.

PAINT PREPARED ALUMINUM (Aluminum products only)

Allows for field applied paint. Surface preparation includes degreasing and a chemical cleaning followed by a clean rinse. Finish coat should be field applied as soon as possible.

MILL FINISH

Surface is left untreated and requires cleaning, degreasing, etc. in the field before final finish can be applied if required.



Nailor[®]
Industries Inc.

STANDARD AND OPTIONAL FINISHES FOR GRILLES AND DIFFUSERS

The following standard colors and finishes are available on applicable Nailor air distribution products. Consult individual product pages for availability

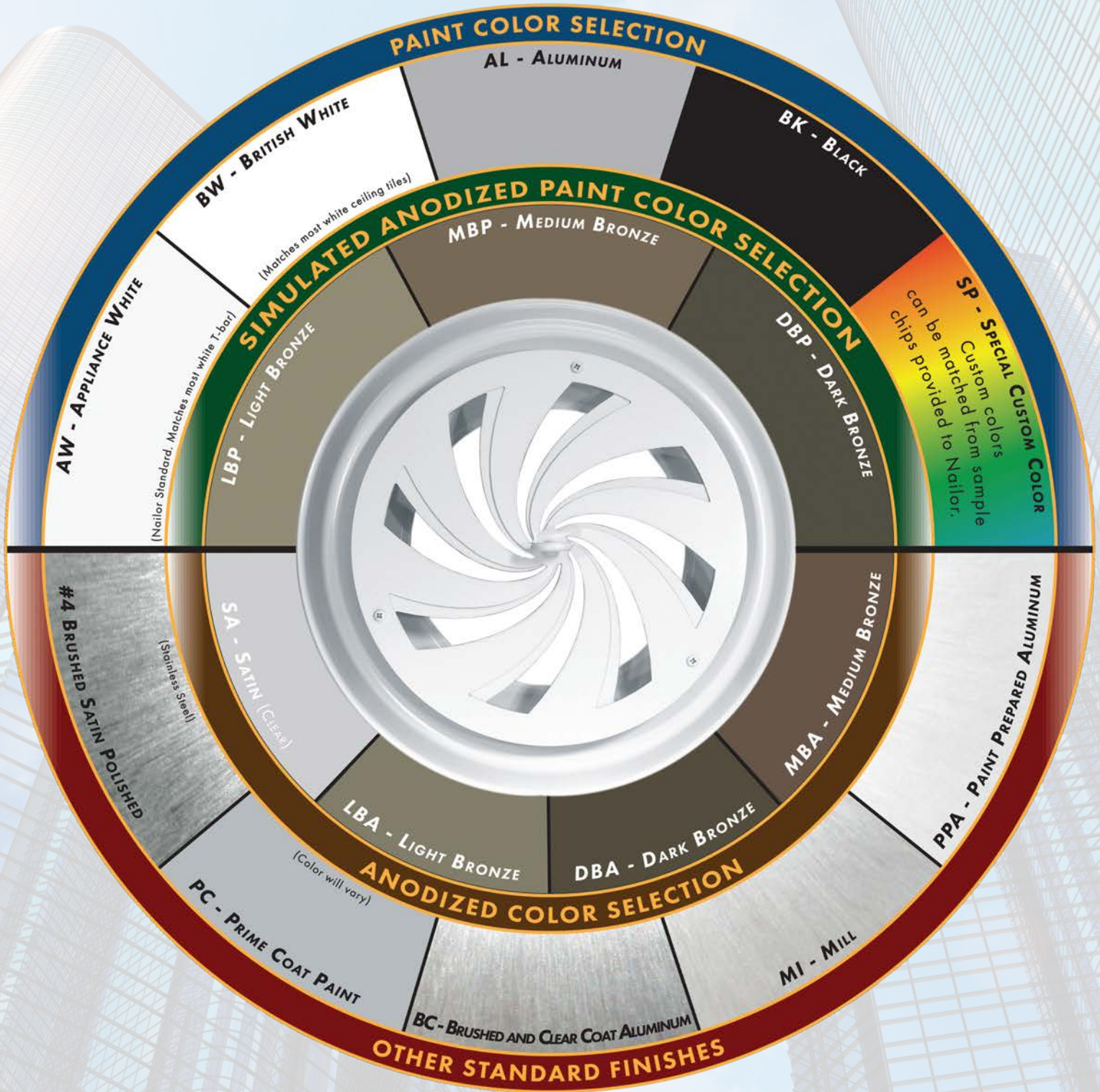

The pictured finishes have been represented as best as possible within printing limitations. However, actual finish may vary. Contact your Nailor representative for a color chip sample on the material specified for a more accurate representation.

DBK - Black (for registers ordered with factory mounted dampers) - **BA** - Perforated Diffusers (4300 series only) Appliance White (AW) face with black back pan and pattern controllers.

"Complete Air Control and Distribution Solutions."

WGDSOF2015

www.nailor.com