



**EXTRUDED ALUMINUM STATIONARY HYBRID LOUVER**  
**MIAMI-DADE QUALIFIED • FLORIDA PRODUCT APPROVED**  
**HIGH VELOCITY WIND-DRIVEN RAIN RESISTANT**  
**5.4" (137) DEEP • HORIZONTAL AND VERTICAL BLADE**  
**MODEL: 1605HM**

**QUALIFICATIONS:**

- Miami-Dade County NOA No. 25-1223.02
- Florida Product Approval No. PENDING
- Tested in accordance with: TAS-201 (Missile Impact Test), TAS-202 (Uniform Static Air Pressure Test), TAS-203 (Cyclic Wind Pressure Loading Test.)
- AMCA 500-L (Wind-Drive Rain, Water Penetration, Air Performance)
- AMCA 540 (Wind-Borne Debris Impact Test [Enhanced "Level E" Protection]).
- AMCA 550 (High Velocity Wind-Driven Rain Resistance Test).
- Wind load rating +/- 100 PSF

**STANDARD CONSTRUCTION:**

- FRAME:** 5.4" (137) deep, Type 6063-T6 extruded aluminum, .080" (2.03) nominal wall thickness. Integral caulking slot provided.
- BLADES:** **Front:** Horizontal Type 6063-T6 extruded aluminum, .080" (2.03) nominal wall thickness, with reinforcing bosses. J style.  
**Rear:** Vertical Type 6063-T6 extruded aluminum, .060" (1.52) nominal wall thickness, with reinforcing bosses.
- BLADE SPACING:** **Front:** Approximately 1.965" (50) on centers.  
**Rear:** Approximately .875" (22) on centers.
- BLADE SUPPORT:** 2.5" (64) strap every 60" (1524) or less in height
- SCREEN:** 3/4" x .050 (19 x 1.3) expanded, flattened aluminum bird screen in removable frame, inside (rear) mount (adds approximately 3/8" [10] to louver depth).
- FINISH:** Mill.
- MINIMUM SIZE:** 12" W x 12" H (305 x 305).
- MAX. SINGLE** 60" W x 120" H (1524 x 3048).
- SECTION SIZE:** 50 ft<sup>2</sup> (4.6 m<sup>2</sup>). Larger louvers will require field assembly of smaller sections.
- MAXIMUM SIZE:** Unlimited Width x 120" H (3048).

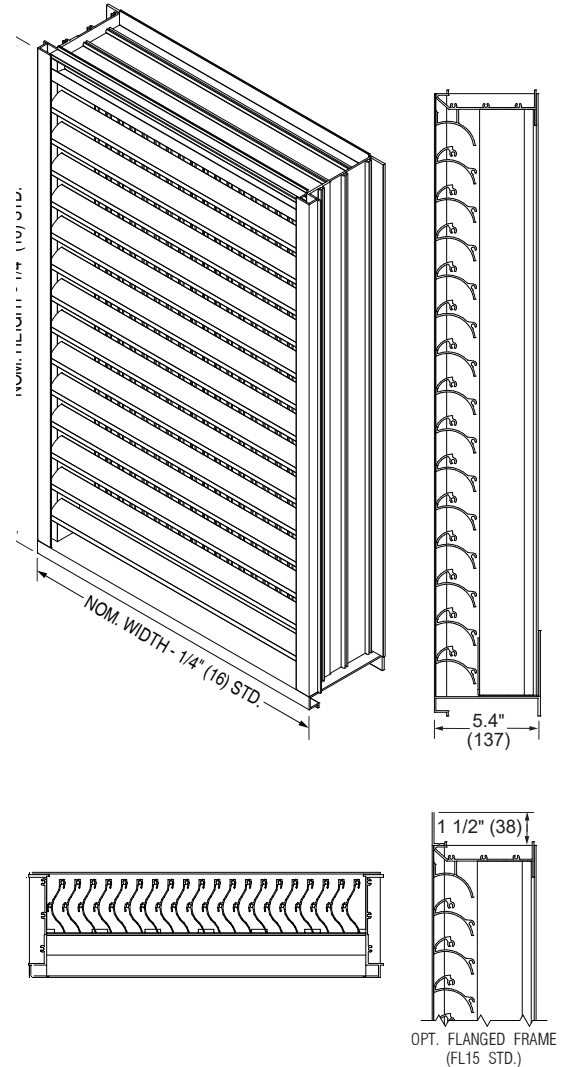

**OPTIONS:**

- BSSS** Type 304 S.S. Bird Screen.
- BSN** No Bird Screen.
- ISSS** Type 304 S.S. Insect Screen.
- ISA** Aluminum Insect Screen.
- FL15** Flanged Frame, 1 1/2" (38).
- FL20** Flanged Frame, 2" (51).
- PASI** Sill Pan.
- PAAA** Perimeter Anchor Angles (Aluminum, Continuous).
- Other: \_\_\_\_\_

**OPTIONAL FINISHES:**

- PC3** Powder Coat AAMA 2603. Color: \_\_\_\_\_.
- PC4** High Performance Powder Coat AAMA 2604 (Equivalent to 50% Kynar®). Color: \_\_\_\_\_.
- PC5** Fluoropolymer Powder Coat AAMA 2605 (Equivalent to 70% Kynar®). Color: \_\_\_\_\_.
- PCC** Prime Coat.
- AN04** Clear Anodized 204-R1.
- AN15** Clear Anodized 215-R1.
- ANLB** Light Bronze.
- ANMB** Medium Bronze.
- ANDB** Dark Bronze.
- ANBK** Black.

<b>SCHEDULE TYPE:</b>		Page 1 of 3			
<b>PROJECT:</b>		Dimensions are in inches (mm).			
<b>ENGINEER:</b>	<b>DATE</b>	<b>B SERIES</b>	<b>SUPERSEDES</b>	<b>DRAWING NO.</b>	
<b>CONTRACTOR:</b>	06 - 1 - 26	1600M	05 - 15 - 26	1605HM	



**EXTRUDED ALUMINUM STATIONARY HYBRID LOUVER**  
**MIAMI-DADE QUALIFIED • FLORIDA PRODUCT APPROVED**  
**HIGH VELOCITY WIND-DRIVEN RAIN RESISTANT**  
**5.4" (137) DEEP • HORIZONTAL AND VERTICAL BLADE**  
**PERFORMANCE DATA**  
**MODEL: 1605HM**

**FREE AREA in Square Feet and Square Meters**

		Width in Inches and Meters								
		12	18	24	30	36	42	48	54	60
Height in Inches and Meters	12	0.22	0.38	0.51	0.67	0.82	0.98	1.13	1.29	1.44
	0.30	0.02	0.04	0.05	0.06	0.08	0.09	0.11	0.12	0.13
	18	0.45	0.77	1.04	1.36	1.67	1.99	2.31	2.62	2.94
	0.46	0.04	0.07	0.10	0.13	0.16	0.18	0.21	0.24	0.27
	24	0.68	1.16	1.57	2.05	2.53	3.00	3.48	3.96	4.44
	0.61	0.06	0.11	0.15	0.19	0.23	0.28	0.32	0.37	0.41
	30	0.91	1.55	2.10	2.74	3.38	4.02	4.66	5.30	5.94
	0.76	0.08	0.14	0.20	0.25	0.31	0.37	0.43	0.49	0.55
	36	1.14	1.94	2.63	3.43	4.23	5.03	5.83	6.63	7.43
	0.36	0.11	0.18	0.24	0.32	0.39	0.47	0.54	0.62	0.69
	42	1.37	2.34	3.16	4.12	5.08	6.05	7.01	7.97	8.93
	1.07	0.13	0.22	0.29	0.38	0.47	0.56	0.65	0.74	0.83
	48	1.60	2.73	3.69	4.81	5.94	7.06	8.18	9.31	10.43
	1.22	0.15	0.25	0.34	0.45	0.55	0.66	0.76	0.86	0.97
	54	1.83	3.12	4.22	5.50	6.79	8.07	9.36	10.64	11.93
	1.37	0.17	0.29	0.39	0.51	0.63	0.75	0.87	0.99	1.11
	60	2.07	3.51	4.75	6.20	7.64	9.09	10.53	11.98	13.42
	1.52	0.19	0.33	0.44	0.58	0.71	0.84	0.98	1.11	1.25
	66	2.30	3.90	5.28	6.89	8.49	10.10	11.71	13.32	14.92
	1.68	0.21	0.36	0.49	0.64	0.79	0.94	1.09	1.24	1.39
72	2.53	4.29	5.81	7.58	9.35	11.11	12.88	14.65	16.42	
1.83	0.23	0.40	0.54	0.70	0.87	1.03	1.20	1.36	1.53	
78	2.76	4.69	6.34	8.27	10.20	12.13	14.06	15.99	17.92	
1.98	0.26	0.44	0.59	0.77	0.95	1.13	1.31	1.49	1.66	
84	2.99	5.08	6.87	8.96	11.05	13.14	15.23	17.32	19.42	
2.13	0.28	0.47	0.64	0.83	1.03	1.22	1.42	1.61	1.80	
90	3.22	5.47	7.40	9.65	11.90	14.16	16.41	18.66	20.91	
2.29	0.30	0.51	0.69	0.90	1.11	1.32	1.52	1.73	1.94	
96	3.45	5.86	7.93	10.34	12.76	15.17	17.58	20.00	22.41	
2.44	0.32	0.54	0.74	0.96	1.19	1.41	1.63	1.86	2.08	
102	3.68	6.25	8.46	11.03	13.61	16.18	18.76	21.33	23.91	
2.59	0.34	0.58	0.79	1.03	1.26	1.50	1.74	1.98	2.22	
108	3.91	6.64	8.99	11.73	14.46	17.20	19.93	22.67	25.41	
2.74	0.36	0.62	0.84	1.09	1.34	1.60	1.85	2.11	2.36	
114	4.14	7.04	9.52	12.42	15.31	18.21	21.11	24.01	26.90	
2.90	0.38	0.65	0.88	1.15	1.42	1.69	1.96	2.23	2.50	
120	4.37	7.43	10.05	13.11	16.17	19.23	22.28	25.34	28.40	
3.05	0.41	0.69	0.93	1.22	1.50	1.79	2.07	2.35	2.64	



<b>SCHEDULE TYPE:</b>	Page 2 of 3			
<b>PROJECT:</b>	Dimensions are in inches (mm).			
<b>ENGINEER:</b>	<b>DATE</b>	<b>B SERIES</b>	<b>SUPERSEDES</b>	<b>DRAWING NO.</b>
<b>CONTRACTOR:</b>	06 - 1 - 26	1600M	05 - 15 - 26	1605HM



**EXTRUDED ALUMINUM STATIONARY HYBRID LOUVER**  
**MIAMI-DADE QUALIFIED • FLORIDA PRODUCT APPROVED**  
**HIGH VELOCITY WIND-DRIVEN RAIN RESISTANT**  
**5.4" (137) DEEP • HORIZONTAL AND VERTICAL BLADE**  
**PERFORMANCE DATA**  
**MODEL: 1605HM**

**AIRFLOW/WATER PENETRATION DATA**  
**for 48" x 48" (1219 x 1219) Louver Size**

Free Area %	51%	
Free Area sq. ft. (sq. m.)	8.18 (0.76)	
I N T A K E	Free Area Velocity at Point of Beginning Water Penetration at .01 oz./sq. ft. (3 ml/sq. m) (15 min. test duration)	1250 fpm (381 m/min.)
	Air Volume at 1250 fpm Free Area Velocity	10,225 cfm (4826 l/s)
	Pressure Drop @ 1250 fpm	.66 in. w.g. (164 Pa)

**NOTE:** To minimize water penetration when sizing intake louvers, select a Free Area Velocity that is **below** the beginning point of water penetration.

**WIND DRIVEN RAIN PERFORMANCE**

Core Ventilation	0	98	197	295	393	492	590	688	787	889	975
Rate in fpm (m/s)	(0.00)	(0.50)	(1.00)	(1.50)	(2.00)	(2.50)	(3.00)	(3.50)	(4.00)	(4.52)	(4.95)
Free Area Ventilation	0	169	339	508	678	848	1017	1186	1355	1498	1644
Rate in fpm (m/s)	(0.00)	(0.86)	(1.72)	(2.58)	(3.44)	(4.31)	(5.17)	(6.02)	(6.88)	(7.61)	(8.35)
Effectiveness Ratio (%)	100	100	100	100	100	100	100	100	100	100	99.8
Penetration Class	A	A	A	A	A	A	A	A	A	A	A

Test was based on a 39.375" x 39.375" (1.0 m x 1.0 m) core area louver tested at a rainfall rate of 3" per hour (76 mm/hour) with a wind velocity of **29 mph (13 m/s)**.

Core Ventilation	0	94	190	291	398	477	576	677	762	867	948
Rate in fpm (m/s)	(0.00)	(0.48)	(0.97)	(1.48)	(2.02)	(2.42)	(2.93)	(3.44)	(3.87)	(4.40)	(4.82)
Free Area Ventilation	0	161	327	501	685	821	993	1166	1285	1473	1611
Rate in fpm (m/s)	(0.00)	(0.82)	(1.66)	(2.55)	(3.48)	(4.17)	(5.04)	(5.92)	(6.53)	(7.48)	(8.18)
Effectiveness Ratio (%)	100	100	100	100	100	100	100	100	99.8	99.7	99.6
Penetration Class	A	A	A	A	A	A	A	A	A	A	A

Test was based on a 39.375" x 39.375" (1.0 m x 1.0 m) core area louver tested at a rainfall rate of 8" per hour (203 mm/hour) with a wind velocity of **50 mph (22 m/s)**.

Wind Driven Rain Penetration Classes	
Class	Effectiveness
A	1 to 0.99
B	0.989 to .95
C	0.949 to .80
D	Below 0.80



Nailor Industries Inc. certifies that the Model 1605HM shown herein is licensed to bear the AMCA Certified Ratings Program seal. The ratings shown are based on tests and procedures performed in accordance with AMCA Publication 511 and comply with the requirements of the AMCA Certified Ratings Program. The AMCA Certified Ratings Program seal applies to Water Penetration, Wind Driven Rain, and Air Performance ratings.

Louvers were tested in accordance with AMCA Standard 500-L.



**PRESSURE DROP**

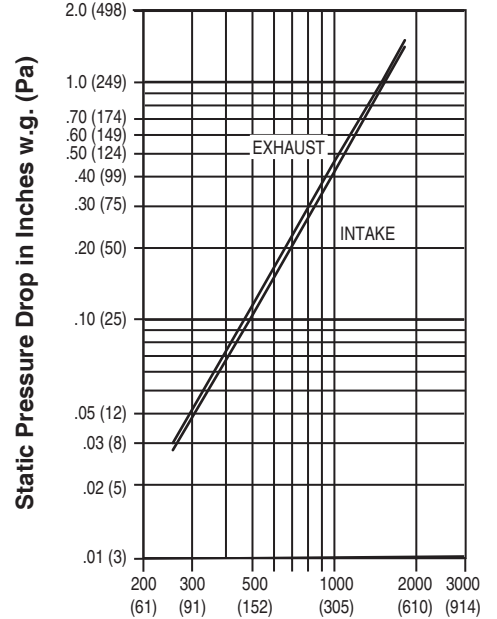

**Air Velocity in Feet (Meters) Per Minute Through Free Area**

Louver test size: 48" x 48" (1219 x 1219 mm).  
 Standard air density @ 0.075 lbs/ft<sup>3</sup>.  
 Tested to AMCA Fig. 5.5 – 6.5.



Nailor Industries Inc. certifies that the 1605HM louver shown herein is approved to bear the AMCA International Listing Label. The ratings shown are based on tests and procedures performed in accordance with AMCA publications and comply with the requirements of the AMCA International Listing Label program. The AMCA International Listing Label applies to wind borne debris impact resistant louvers rated for Enhanced Protection and +/- 100PSF with a minimum blade span of less than 12 in. (305mm) and a maximum unsupported blade span of 58 in. (1473 mm) and to High Velocity Wind-Driven Rain Resistant Louvers tested in the fully open position that permits airflow through a louver.

<b>SCHEDULE TYPE:</b>			
<b>PROJECT:</b>			
<b>ENGINEER:</b>			
<b>CONTRACTOR:</b>			
<b>DATE</b>	<b>B SERIES</b>	<b>SUPERSEDES</b>	<b>DRAWING NO.</b>
06 - 1 - 26	1600M	05 - 15 - 26	1605HM



**EXTRUDED ALUMINUM STATIONARY HYBRID LOUVER**  
**MIAMI-DADE QUALIFIED • FLORIDA PRODUCT APPROVED**  
**HIGH VELOCITY WIND-DRIVEN RAIN AND IMPACT RESISTANT**  
**9" (229) DEEP • HORIZONTAL AND VERTICAL BLADE**  
**MODEL: 1609HM**

**QUALIFICATIONS:**

- Miami-Dade County 23-0823.05
- Florida Product Approval 41947.1
- Tested in accordance with: TAS-100A (Wind-Driven Rain Test), TAS-201 (Large Missile Impact Test), TAS-202 (Uniform Static Air Pressure Test), TAS-203 (Cyclic Wind Pressure Loading Test).
- AMCA 500-L (Wind-Driven Rain, Water Penetration, Air Performance).
- AMCA 540 (Wind-Borne Debris Impact Test [Enhanced "Level E" Protection]).
- AMCA 550 (High Velocity Wind-Driven Rain Resistance Test).
- Wind load rating +/- 160 PSF.

**STANDARD CONSTRUCTION:**

**FRAME:** **Front:** 4" (102) deep, Type 6063-T6 extruded aluminum, .080" (2.03) nominal wall thickness. Integral caulking slot provided.

**Rear:** 5" (127) deep, Type 6063-T6 extruded aluminum, .080" (2.03) nominal wall thickness. Integral downspouts provided.

**BLADES:** **Front:** Horizontal Type 6063-T6 extruded aluminum, .080" (2.03) nominal wall thickness, with reinforcing bosses. J style. Fixed at 37 degrees.

**Rear:** Vertical Type 6063-T6 extruded aluminum, .060" (1.52) nominal wall thickness, with reinforcing bosses.

**BLADE SPACING:** **Front:** Approx. 4" (102) on centers.  
**Rear:** Approx. 1 1/2" (38) on centers.

**BLADE SUPPORT:** **Front:** Concealed type, factory installed on rear of louver on maximum 60" (1524) centers.

**Rear:** 2.5" (64) strap every 60" (1524) or less in height.

**SCREEN:** 3/4" x .050 (19 x 1.3) expanded, flattened aluminum bird screen in removable frame, inside (rear) mount (adds approximately 3/8" [10] to louver depth).

**SILL PAN:** Aluminum sill pan with end dams. (louver width undersized an additional 1/4" (6) to accommodate sill pan).

**FINISH:** Mill.

**MINIMUM SIZE:** 12" W x 12" H (305 x 305).

**MAXIMUM SINGLE:** 60" W x 120" H (1524 x 3048). 50 sq. ft.

**SECTION SIZE:** (4.6 m<sup>2</sup>). Larger louvers will require field assembly of smaller sections.

**MAXIMUM SIZE:** Unlimited Width x 120" H (3048).

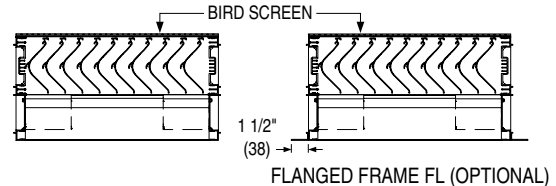
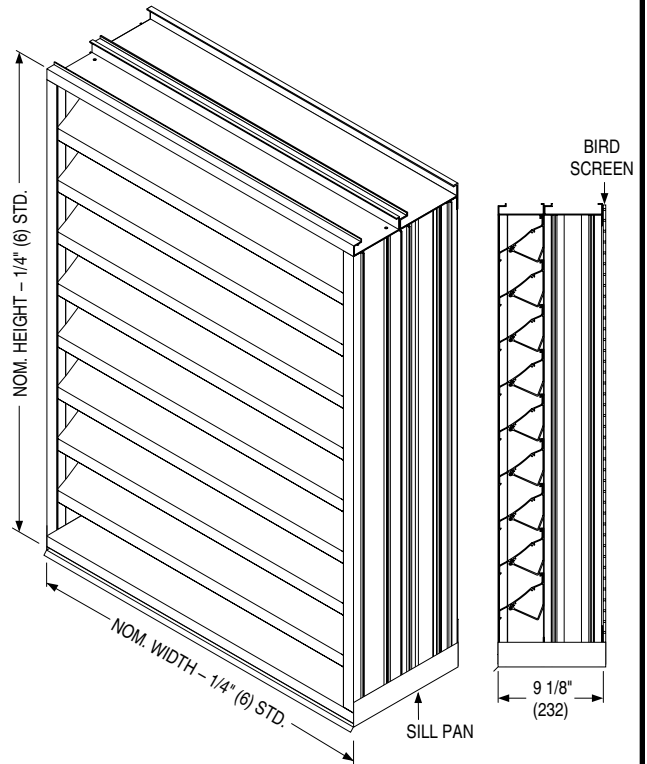

**OPTIONS:**

- BSSS** Type 304 S. S. Bird Screen.
- BSN** No Bird Screen.
- ISSS** Type 304 S. S. Insect Screen.
- ISA** Aluminum Insect Screen.
- FL15** Flanged Frame, 1 1/2" (38).
- FL20** Flanged Frame, 2" (51).
- Other: \_\_\_\_\_ .

**OPTIONAL FINISHES:**

- PC3** Powder Coat AAMA 2603. Color: \_\_\_\_\_ .
- PC4** High Performance Powder Coat AAMA 2604 (Equivalent to 50% Kynar®). Color: \_\_\_\_\_ .
- PC5** Fluoropolymer Powder Coat AAMA 2605 (Equivalent to 70% Kynar®). Color: \_\_\_\_\_ .
- PCC** Prime Coat.
- AN04** Clear Anodized 204-R1.
- AN15** Clear Anodized 215-R1.

<b>SCHEDULE TYPE:</b>	
<b>PROJECT:</b>	
<b>ENGINEER:</b>	
<b>CONTRACTOR:</b>	

Page 1 of 3  
Dimensions are in inches (mm).

DATE	B SERIES	SUPERSEDES	DRAWING NO.
4 - 12 - 24	1600M	NEW	1609HM



**EXTRUDED ALUMINUM STATIONARY HYBRID LOUVER**  
**MIAMI-DADE QUALIFIED • FLORIDA PRODUCT APPROVED**  
**HIGH VELOCITY WIND-DRIVEN RAIN AND IMPACT RESISTANT**  
**9" (229) DEEP • HORIZONTAL AND VERTICAL BLADE**  
**PERFORMANCE DATA**  
**MODEL: 1609HM**

**FREE AREA in Square Feet and Square Meters**

		Width in Inches and Meters								
		12	18	24	30	36	42	48	54	60
<b>Height in Inches and Meters</b>	<b>12</b>	0.21	0.39	0.56	0.73	0.90	1.07	1.24	1.41	1.58
	0.30	0.02	0.04	0.05	0.07	0.08	0.10	0.12	0.13	0.15
	<b>18</b>	0.42	0.76	1.10	1.44	1.78	2.12	2.46	2.80	3.13
	0.46	0.04	0.07	0.10	0.13	0.17	0.20	0.23	0.26	0.29
	<b>24</b>	0.63	1.14	1.65	2.15	2.66	3.17	3.67	4.18	4.69
	0.61	0.06	0.11	0.15	0.20	0.25	0.29	0.34	0.39	0.44
	<b>30</b>	0.84	1.52	2.19	2.87	3.54	4.21	4.89	5.56	6.24
	0.76	0.08	0.14	0.20	0.27	0.33	0.39	0.45	0.52	0.58
	<b>36</b>	1.05	1.89	2.74	3.58	4.42	5.26	6.10	6.95	7.79
	0.36	0.10	0.18	0.25	0.33	0.41	0.49	0.57	0.65	0.72
	<b>42</b>	1.26	2.27	3.28	4.29	5.30	6.31	7.32	8.33	9.34
	1.07	0.12	0.21	0.30	0.40	0.49	0.59	0.68	0.77	0.87
	<b>48</b>	1.47	2.65	3.83	5.00	6.18	7.36	8.53	9.71	10.89
	1.22	0.14	0.25	0.36	0.46	0.57	0.68	0.79	0.90	1.01
	<b>54</b>	1.68	3.03	4.37	5.72	7.06	8.41	9.75	11.09	12.44
	1.37	0.16	0.28	0.41	0.53	0.66	0.78	0.91	1.03	1.16
	<b>60</b>	1.89	3.40	4.92	6.43	7.94	9.45	10.97	12.48	13.99
	1.52	0.18	0.32	0.46	0.60	0.74	0.88	1.02	1.16	1.30
	<b>66</b>	2.10	3.78	5.46	7.14	8.82	10.50	12.18	13.86	15.54
	1.68	0.20	0.35	0.51	0.66	0.82	0.98	1.13	1.29	1.44
<b>72</b>	2.31	4.16	6.01	7.85	9.70	11.55	13.40	15.24	17.09	
1.83	0.21	0.39	0.56	0.73	0.90	1.07	1.24	1.42	1.59	
<b>78</b>	2.52	4.53	6.55	8.57	10.58	12.60	14.61	16.63	18.64	
1.98	0.23	0.42	0.61	0.80	0.98	1.17	1.36	1.54	1.73	
<b>84</b>	2.73	4.91	7.10	9.28	11.46	13.64	15.83	18.01	20.19	
2.13	0.25	0.46	0.66	0.86	1.06	1.27	1.47	1.67	1.88	
<b>90</b>	2.94	5.29	7.64	9.99	12.34	14.69	17.04	19.39	21.75	
2.29	0.27	0.49	0.71	0.93	1.15	1.36	1.58	1.80	2.02	
<b>96</b>	3.15	5.67	8.19	10.70	13.22	15.74	18.26	20.78	23.30	
2.44	0.29	0.53	0.76	0.99	1.23	1.46	1.70	1.93	2.16	
<b>102</b>	3.36	6.04	8.73	11.42	14.10	16.79	19.47	22.16	24.85	
2.59	0.31	0.56	0.81	1.06	1.31	1.56	1.81	2.06	2.31	
<b>108</b>	3.57	6.42	9.27	12.13	14.98	17.84	20.69	23.54	26.40	
2.74	0.33	0.60	0.86	1.13	1.39	1.66	1.92	2.19	2.45	
<b>114</b>	3.78	6.80	9.82	12.84	15.86	18.88	21.91	24.93	27.95	
2.90	0.35	0.63	0.91	1.19	1.47	1.75	2.04	2.32	2.60	
<b>120</b>	3.99	7.18	10.36	13.55	16.74	19.93	23.12	26.31	29.50	
3.05	0.37	0.67	0.96	1.26	1.56	1.85	2.15	2.44	2.74	

<b>SCHEDULE TYPE:</b>	Page 2 of 3 Dimensions are in inches (mm).			
<b>PROJECT:</b>				
<b>ENGINEER:</b>	<b>DATE</b>	<b>B SERIES</b>	<b>SUPERSEDES</b>	<b>DRAWING NO.</b>
<b>CONTRACTOR:</b>	4 - 12 - 24	1600M	NEW	1609HM



**EXTRUDED ALUMINUM STATIONARY HYBRID LOUVER**  
**MIAMI-DADE QUALIFIED • FLORIDA PRODUCT APPROVED**  
**HIGH VELOCITY WIND-DRIVEN RAIN AND IMPACT RESISTANT**  
**9" (229) DEEP • HORIZONTAL AND VERTICAL BLADE**  
**PERFORMANCE DATA**  
**MODEL: 1609HM**

**AIRFLOW/WATER PENETRATION DATA**  
**for 48" x 48" (1219 x 1219) Louver Size**

Free Area %	53%	
Free Area sq. ft. (sq. m.)	8.53 (0.79)	
<b>I N T A K E</b>	Free Area Velocity at Point of Beginning Water Penetration at .01 oz./sq. ft. (3 ml/sq. m) (15 min. test duration)	1011 fpm (308 m/min.)
	Air Volume at 1011 fpm	8,624 cfm (4070 l/s)
	Free Area Velocity	
	Pressure Drop @ 1011 fpm	.34 in. w.g. (85 Pa)

**NOTE:** To minimize water penetration when sizing intake louvers, select a Free Area Velocity that is **below** the beginning point of water penetration.

**WIND DRIVEN RAIN PERFORMANCE**

Core Ventilation	0	99	198	297	393	494	590	690	789	889	985
Rate in fpm (m/s)	(0.00)	(0.50)	(1.01)	(1.51)	(2.00)	(2.51)	(3.00)	(3.51)	(4.01)	(4.52)	(5.00)
Free Area Ventilation	0	174	348	522	690	868	1036	1212	1386	1561	1730
Rate in fpm (m/s)	(0.00)	(0.88)	(1.77)	(2.65)	(3.51)	(4.41)	(5.26)	(6.16)	(7.04)	(7.93)	(8.79)
Effectiveness Ratio (%)	100	100	100	100	100	100	100	100	100	100	99.9
Penetration Class	A	A	A	A	A	A	A	A	A	A	A

Test was based on a 39.375" x 39.375" (1.0 m x 1.0 m) core area louver tested at a rainfall rate of 3" per hour (76 mm/hour) with a wind velocity of **29 mph (13 m/s)**.

DISCHARGE LOSS COEFFICIENT CLASS (INTAKE): 3. (Discharge Loss Coefficient Classification is as follows: 1=0.4 and above, 2=0.3 to 0.399, 3 = 0.2 to 0.299, 4 = 0.199 and below.)

Core Ventilation	0	96	197	288	396	482	593	691	793	894	988
Rate in fpm (m/s)	(0.00)	(0.49)	(1.00)	(1.46)	(2.01)	(2.45)	(3.01)	(3.51)	(4.03)	(4.54)	(5.02)
Free Area Ventilation	0	169	346	506	696	847	1042	1214	1393	1570	1735
Rate in fpm (m/s)	(0.00)	(0.86)	(1.76)	(2.57)	(3.54)	(4.30)	(5.29)	(6.17)	(7.08)	(7.98)	(8.81)
Effectiveness Ratio (%)	100	100	100	100	100	100	99.8	99.6	99.1	98.5	97.9
Penetration Class	A	A	A	A	A	A	A	A	A	B	B

Test was based on a 39.375" x 39.375" (1.0 m x 1.0 m) core area louver tested at a rainfall rate of 8" per hour (203 mm/hour) with a wind velocity of **50 mph (22 m/s)**.

DISCHARGE LOSS COEFFICIENT CLASS (INTAKE): 3. (Discharge Loss Coefficient Classification is as follows: 1=0.4 and above, 2=0.3 to 0.399, 3 = 0.2 to 0.299, 4 = 0.199 and below.)



Nailor Industries Inc. certifies that the Model 1609HM shown herein is licensed to bear the AMCA Certified Ratings Program seal. The ratings shown are based on tests and procedures performed in accordance with AMCA Publication 511 and comply with the requirements of the AMCA Certified Ratings Program. The AMCA Certified Ratings Program seal applies to air performance, water penetration and wind driven rain performance ratings.

Louvers were tested in accordance with AMCA Standard 500-L.



**PRESSURE DROP**

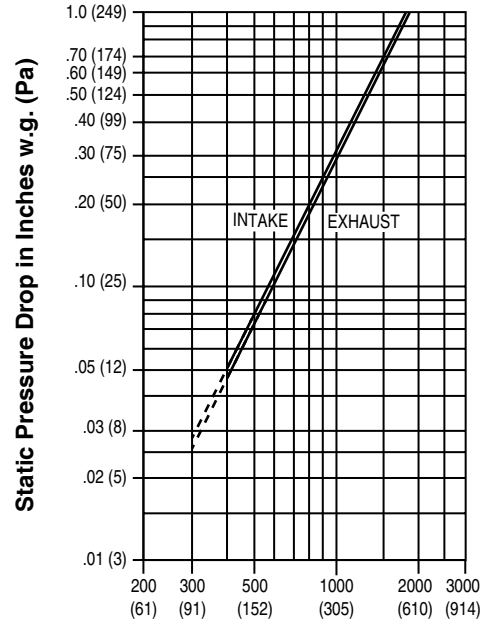

**Air Velocity in Feet (Meters) Per Minute Through Free Area**

Louver test size: 48" x 48" (1219 x 1219 mm).  
 Standard air density @ 0.075 lbs/ft<sup>3</sup>.  
 Tested to AMCA Fig. 5.5 – 6.5.



Nailor Industries Inc. certifies that the 1609HM shown herein is approved to bear the AMCA International Listing Label. The ratings shown are based on tests and procedures performed in accordance with AMCA publications and comply with the requirements of the AMCA International Listing Label program. The AMCA International Listing Label applies to pressure cycle tested wind borne debris impact resistant louvers rated for 'Enhanced Protection' and +/- 160PSF with a minimum blade span of 12 in. (305mm) and a maximum unsupported blade span of 59 in. (1499 mm) and to High Velocity Wind-Driven Rain Resistant Louvers tested in the fully open position that permits airflow through a louver.

<b>SCHEDULE TYPE:</b>	
<b>PROJECT:</b>	
<b>ENGINEER:</b>	
<b>CONTRACTOR:</b>	

Page 3 of 3  
 Dimensions are in inches (mm).

<b>DATE</b>	<b>B SERIES</b>	<b>SUPERSEDES</b>	<b>DRAWING NO.</b>
4 - 12 - 24	1600M	NEW	1609HM

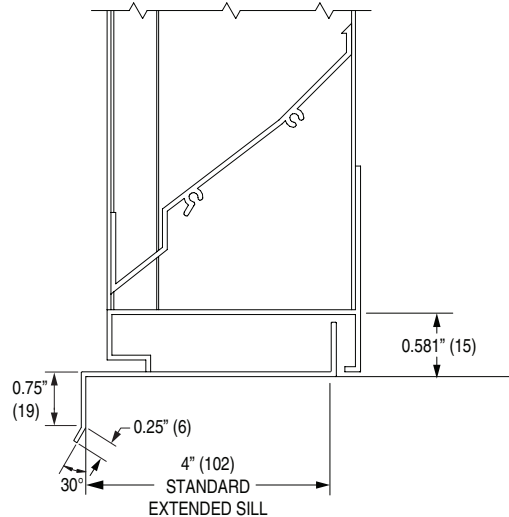
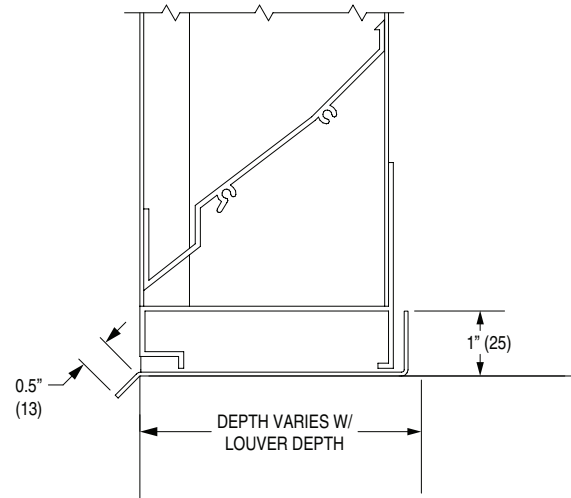
**ESI** Extended Sill

 **PASI** Sill Pan (Extended Sill with End Dams)

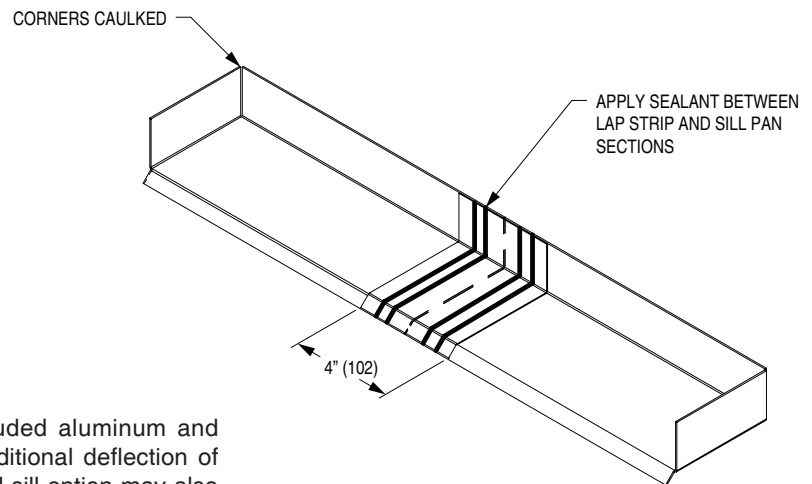
**SILL PAN (Side View)**

\*Shipped in sections for multiple section width louvers where necessary.

**APPLICATION:**

Sill extensions are available on all Nailor extruded aluminum and formed steel louver models and can provide additional deflection of water away from the louver opening. An extended sill option may also provide a transition between the louver and adjacent structures.

**NOTES:**

1. The finish will match the louver.
2. When ordered, sill extensions are shipped loose for field installation.
3. Customization available upon request.

**MATERIALS:**

1. **ESI** Extended Sill 6063-T6 0.081" (2.1) thick extruded aluminum.
2. **PASI** Extended Sill 5052-H32 0.060" (1.5) thick formed aluminum

<b>SCHEDULE TYPE:</b>		Dimensions are in inches (mm).			
<b>PROJECT:</b>					
<b>ENGINEER:</b>	<b>DATE</b>	<b>B SERIES</b>	<b>SUPERSEDES</b>	<b>DRAWING NO.</b>	
<b>CONTRACTOR:</b>	1 - 29 - 26	ACC-ESI	New	ACC-ESI	