

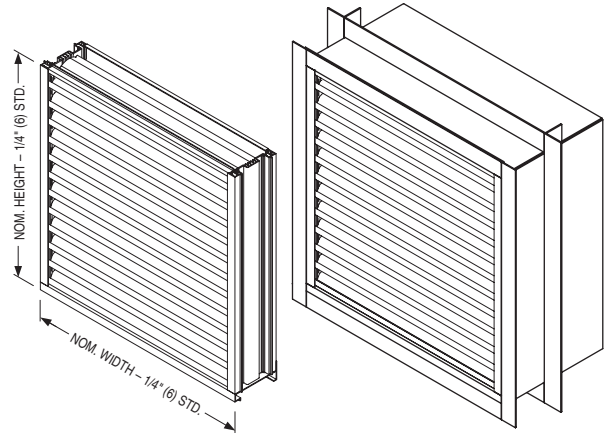

EXTRUDED ALUMINUM STATIONARY LOUVER
MIAMI-DADE QUALIFIED • FLORIDA PRODUCT APPROVED
WIND-DRIVEN RAIN RESISTANT
5" (127) DEEP • HORIZONTAL BLADE
MODEL: 1605WDM

QUALIFICATIONS:

- Miami-Dade County NOA No. : 24-0516.05
- Florida Product Approval No. 41441.1
- Texas Department of Insurance Evaluation ID: LVR-28
- Tested in accordance with: TAS-201 (Large Missile Impact Test), TAS-202 (Uniform Static Air Pressure Test), TAS-203 (Cyclic Wind Pressure Loading Test), TAS-100A (Wind-Driven Rain Test [with optional Model 2020 damper in closed position]).
- AMCA 500-L (Wind-Driven Rain, Water Penetration, Air Performance).
- AMCA 540 (Wind-Borne Debris Impact Test [Enhanced "Level E" Protection]).
- AMCA 550 (High Velocity Wind-Driven Rain Resistance Test [with optional Model 2020 damper in closed position]).
- Wind load rating +/- 150 PSF.



STANDARD CONSTRUCTION:

- FRAME:** 5" (127) deep, Type 6063-T6 extruded aluminum, .080" (2.03) nominal wall thickness. Integral downspouts and caulking slot provided.
- BLADES:** Type 6063-T6 extruded aluminum, .080" (2.03) nominal wall thickness, with reinforcing bosses.
- BLADE ANGLE:** Fixed at 30 degrees.
- BLADE SPACING:** 1.86" (47) on centers.
- BLADE SUPPORT:** Concealed type, factory installed on rear of louver. Reinforced with 2" x 2" (51 x 51) angle (adds approximately 2" [51] to overall louver depth).
- SCREEN:** 3/4" x .050 (19 x 1.27) expanded, flattened aluminum bird screen in removable frame, inside (rear) mount (adds approx. 3/8" [10] to louver depth).
- FINISH:** Mill.
- MINIMUM SIZE:** 12" W x 12" H (305 x 305).
- MAX. SINGLE** 72" W x 120" H (1829 x 3048). 60 sq. ft. (5.6 m²)
- SECTION SIZE:** (36" W x 120" H [914 x 3048] with optional Model 2020 damper). Larger louvers will require field assembly of smaller sections.
- MAXIMUM SIZE:** Unlimited Width x 120" H (3048).

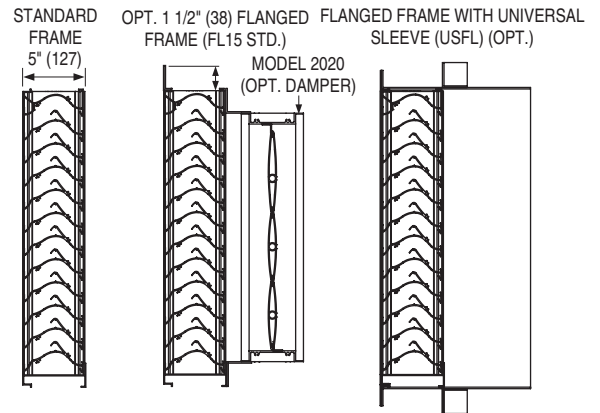

OPTIONS:

- FL15** Flanged Frame, 1 1/2" (38).
- FL20** Flanged Frame, 2" (51).
- USFL** Universal Sleeve/Flanged Frame.
- BSSS** Type 304 S.S. Bird Screen.
- BSN** No Bird Screen.
- ISA** Aluminum Insect Screen.
- ISSS** Type 304 S.S. Insect Screen.
- ESI** Extended Sill.
- PASI** Sill Pan.
- Other: _____.

OPTIONAL FINISHES:

- PC3** Powder Coat AAMA 2603. Color: _____.
- PC4** High Performance Powder Coat AAMA 2604 (Equivalent to 50% Kynar®). Color: _____.
- PC5** Fluoropolymer Powder Coat AAMA 2605 (Equivalent to 70% Kynar®). Color: _____.
- PCC** Prime Coat.
- AN04** Clear Anodized 204-R1.
- AN15** Clear Anodized 215-R1.
- ANLB** Light Bronze.

- ANMB** Medium Bronze.
- ANDB** Dark Bronze.
- ANBK** Black.

OPT. FACTORY MOUNTED 2020 CONTROL DAMPER:

- Extruded Aluminum
- Opposed Airfoil Blades
- Concealed Linkage
- Silicone Blade Seal
- Cambered Stainless Steel Jamb Seals
- 1/2" (13) Plated Steel Axles

SCHEDULE TYPE:	For Installation Instructions, see approved NOA. Page 1 of 3 Dimensions are in inches (mm).			
PROJECT:				
ENGINEER:	DATE	B SERIES	SUPERSEDES	DRAWING NO.
CONTRACTOR:	3 - 27 - 26	1600M	10 - 21 - 24	1605WDM



EXTRUDED ALUMINUM STATIONARY LOUVER
MIAMI-DADE QUALIFIED • FLORIDA PRODUCT APPROVED
WIND-DRIVEN RAIN RESISTANT
5" (127) DEEP • HORIZONTAL BLADE • PERFORMANCE DATA
MODEL: 1605WDM

FREE AREA in Square Feet and Square Meters

		Width in Inches and Meters										
		12	18	24	30	36	42	48	54	60	66	72
		0.30	0.46	0.61	0.76	0.91	1.07	1.22	1.37	1.52	1.68	1.83
Height in Inches and Meters	12	0.27	0.43	0.60	0.76	0.93	1.09	1.26	1.42	1.59	1.75	1.92
	0.30	0.03	0.04	0.06	0.07	0.09	0.10	0.12	0.13	0.15	0.16	0.18
	18	0.47	0.76	1.05	1.34	1.63	1.92	2.20	2.49	2.78	3.07	3.36
	0.46	0.04	0.07	0.10	0.12	0.15	0.18	0.20	0.23	0.26	0.29	0.31
	24	0.74	1.19	1.65	2.10	2.56	3.01	3.46	3.92	4.37	4.82	5.28
	0.61	0.07	0.11	0.15	0.20	0.24	0.28	0.32	0.36	0.41	0.45	0.49
	30	0.94	1.52	2.10	2.68	3.25	3.83	4.41	4.99	5.56	6.14	6.72
	0.76	0.09	0.14	0.19	0.25	0.30	0.36	0.41	0.46	0.52	0.57	0.62
	36	1.15	1.85	2.55	3.25	3.95	4.65	5.35	6.05	6.76	7.46	8.16
	0.36	0.11	0.17	0.24	0.30	0.37	0.43	0.50	0.56	0.63	0.69	0.76
	42	1.35	2.17	3.00	3.82	4.65	5.47	6.30	7.12	7.95	8.77	9.60
	1.07	0.13	0.20	0.28	0.36	0.43	0.51	0.59	0.66	0.74	0.81	0.89
	48	1.62	2.61	3.60	4.59	5.58	6.57	7.59	8.55	9.54	10.53	11.52
	1.22	0.15	0.24	0.33	0.43	0.52	0.61	0.71	0.79	0.89	0.98	1.07
	54	1.82	2.93	4.05	5.16	6.27	7.39	8.50	9.62	10.73	11.84	12.96
	1.37	0.17	0.27	0.38	0.48	0.58	0.69	0.79	0.89	1.00	1.10	1.20
60	2.02	3.26	4.50	5.73	6.97	8.21	9.45	10.68	11.92	13.16	14.40	
1.52	0.19	0.30	0.42	0.53	0.65	0.76	0.88	0.99	1.11	1.22	1.34	
66	2.22	3.58	4.95	6.31	7.67	9.03	10.39	11.75	13.11	14.47	15.84	
1.68	0.21	0.33	0.46	0.59	0.71	0.84	0.97	1.09	1.22	1.34	1.47	
72	2.49	4.02	5.55	7.07	8.60	10.12	11.65	13.18	14.70	16.23	17.76	
1.83	0.23	0.37	0.52	0.66	0.80	0.94	1.08	1.22	1.37	1.51	1.65	
78	2.7	4.35	6.00	7.65	9.30	10.95	12.6	14.25	15.90	17.55	19.20	
1.98	0.25	0.40	0.56	0.71	0.86	1.02	1.17	1.32	1.48	1.63	1.78	
84	2.9	4.67	6.44	8.22	9.99	11.77	13.54	15.31	17.09	18.86	20.63	
2.13	0.27	0.43	0.60	0.76	0.93	1.09	1.26	1.42	1.59	1.75	1.92	
90	3.10	5.00	6.89	8.79	10.69	12.59	14.48	16.38	18.28	20.18	22.07	
2.29	0.29	0.46	0.64	0.82	0.99	1.17	1.35	1.52	1.70	1.87	2.05	
96	3.30	5.32	7.34	9.37	11.39	13.41	15.43	17.45	19.47	21.49	23.51	
2.44	0.31	0.49	0.68	0.87	1.06	1.25	1.43	1.62	1.81	2.00	2.18	
102	3.57	5.76	7.94	10.13	12.32	14.50	16.69	18.87	21.06	23.25	25.43	
2.59	0.33	0.53	0.74	0.94	1.14	1.35	1.55	1.75	1.96	2.16	2.36	
108	3.77	6.08	8.39	10.70	13.01	15.32	17.63	19.94	22.25	24.56	26.87	
2.74	0.35	0.57	0.78	0.99	1.21	1.42	1.64	1.85	2.07	2.28	2.50	
114	3.98	6.41	8.84	11.28	13.71	16.14	18.58	21.01	23.45	25.88	28.31	
2.90	0.37	0.60	0.82	1.05	1.27	1.50	1.73	1.95	2.18	2.40	2.63	
120	4.18	6.73	9.29	11.85	14.41	16.96	19.52	22.08	24.64	27.19	29.75	
3.05	0.39	0.63	0.86	1.10	1.34	1.58	1.81	2.05	2.29	2.53	2.76	

SCHEDULE TYPE:	Page 2 of 3			
PROJECT:	Dimensions are in inches (mm).			
ENGINEER:	DATE	B SERIES	SUPERSEDES	DRAWING NO.
CONTRACTOR:	3 - 27 - 26	1600M	10 - 21 - 24	1605WDM



EXTRUDED ALUMINUM STATIONARY LOUVER
MIAMI-DADE QUALIFIED • FLORIDA PRODUCT APPROVED
WIND-DRIVEN RAIN RESISTANT
5" (127) DEEP • HORIZONTAL BLADE • PERFORMANCE DATA
MODEL: 1605WDM

AIRFLOW/WATER PENETRATION DATA
for 48" x 48" (1219 x 1219) Louver Size

Free Area %		47%
Free Area sq. ft. (sq. m.)		7.59 (0.71)
I N T A K E	Free Area Velocity at Point of Beginning Water Penetration at .01 oz./sq. ft. (3 ml/sq. m) (15 min. test duration)	1250 fpm (381 m/min.)*
	Air Volume at 1250 fpm	9,488 cfm (4478 l/s)
	Free Area Velocity	
	Pressure Drop @ 1250 fpm	.36 in. w.g. (90 Pa)

NOTE: To minimize water penetration when sizing intake louvers, select a Free Area Velocity that is **below** the beginning point of water penetration.*Maximum Free Area Velocity tested is 1250 fpm. Beginning point of water penetration for this model is above 1250 fpm.

WIND DRIVEN RAIN PERFORMANCE

Core Ventilation	0	110	195	279	396	499	585	700	783	884	981
Rate in fpm (m/s)	(0.0)	(0.56)	(0.99)	(1.42)	(2.01)	(2.53)	(2.97)	(3.56)	(3.98)	(4.49)	(4.98)
Free Area Ventilation	0	216	382	547	776	978	1147	1372	1535	1733	1923
Rate in fpm (m/s)	(0.0)	(1.10)	(1.94)	(2.78)	(3.94)	(4.97)	(5.83)	(6.97)	(7.80)	(8.80)	(9.77)
Effectiveness Ratio (%)	100	100	100	100	100	99.6	99.5	99	97.3	94	91.4
Penetration Class	A	A	A	A	A	A	A	A	B	C	C

Test was based on a 39.375" x 39.375" (1.0 m x 1.0 m) core area louver tested at a rainfall rate of 3" per hour (76 mm/hour) with a wind velocity of **29 mph (13 m/s)**.

DISCHARGE LOSS COEFFICIENT CLASS (INTAKE): 3. (Discharge Loss Coefficient Classification is as follows: 1=0.4 and above, 2=0.3 to 0.399, 3 = 0.2 to 0.299, 4 = 0.199 and below.)

Core Ventilation	0	91	198	298	410	487	593	686	785	887	992
Rate in fpm (m/s)	(0.0)	(0.46)	(1.01)	(1.51)	(2.08)	(2.47)	(3.01)	(3.48)	(3.99)	(4.51)	(5.04)
Free Area Ventilation	0	178	388	584	804	955	1162	1345	1539	1739	1944
Rate in fpm (m/s)	(0.0)	(0.90)	(1.97)	(2.97)	(4.08)	(4.85)	(5.90)	(6.83)	(7.82)	(8.94)	(9.88)
Effectiveness Ratio (%)	100	99.6	99.3	99.2	98.6	98.1	97.7	96.4	93.4	89.8	85.5
Penetration Class	A	A	A	A	B	B	B	B	C	C	C

Test was based on a 39.375" x 39.375" (1.0 m x 1.0 m) core area louver tested at a rainfall rate of 8" per hour (203 mm/hour) with a wind velocity of **50 mph (22 m/s)**.

DISCHARGE LOSS COEFFICIENT CLASS (INTAKE): 3. (Discharge Loss Coefficient Classification is as follows: 1=0.4 and above, 2=0.3 to 0.399, 3 = 0.2 to 0.299, 4 = 0.199 and below.)



Nailor Industries Inc. certifies that the Model 1605WDM shown herein is licensed to bear the AMCA Certified Ratings Program seal. The ratings shown are based on tests and procedures performed in accordance with AMCA Publication 511 and comply with the requirements of the AMCA Certified Ratings Program. The AMCA Certified Ratings Program seal applies to Water Penetration, Wind Driven Rain, and Air Performance ratings.

Louvers were tested in accordance with AMCA Standard 500-L.



PRESSURE DROP

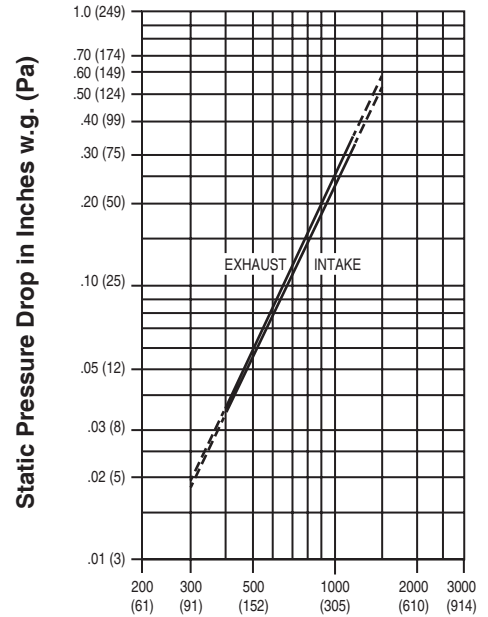

Air Velocity in Feet (Meters) Per Minute Through Free Area

Louver test size: 48" x 48" (1219 x 1219 mm).
 Standard air density @ 0.075 lbs/ft³.
 Tested to AMCA Fig. 5.5 – 6.5.



Nailor Industries Inc. certifies that the 1605WDM louver shown herein is approved to bear the AMCA International Listing Label. The ratings shown are based on tests and procedures performed in accordance with AMCA publications and comply with the requirements of the AMCA International Listing Label program. The AMCA International Listing Label applies to pressure cycle tested wind-borne debris impact resistant louvers rated for Enhanced Protection and +/- 150PSF with a minimum blade span of less than 12 in. (305mm) and a maximum unsupported blade span of 34 in. (864mm). The AMCA International Listing Label applies to High Velocity Wind-Driven Rain Resistant Louvers tested in the fully closed position that stops airflow through a louver.

SCHEDULE TYPE:	
PROJECT:	
ENGINEER:	
CONTRACTOR:	

Page 3 of 3
 Dimensions are in inches (mm).

DATE	B SERIES	SUPERSEDES	DRAWING NO.
3 - 27 - 26	1600M	10 - 21 - 24	1605WDM

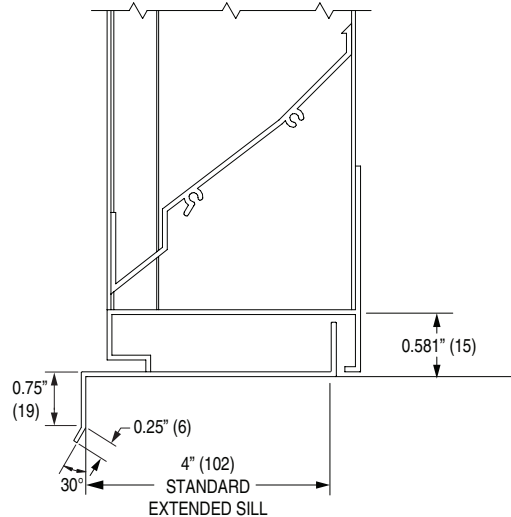
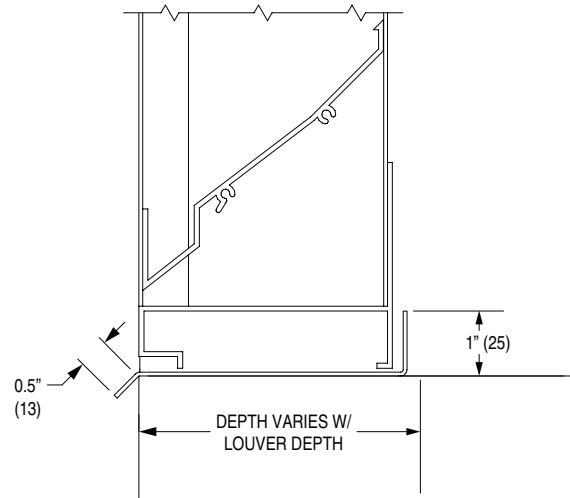
ESI Extended Sill

 PASI Sill Pan (Extended Sill with End Dams)

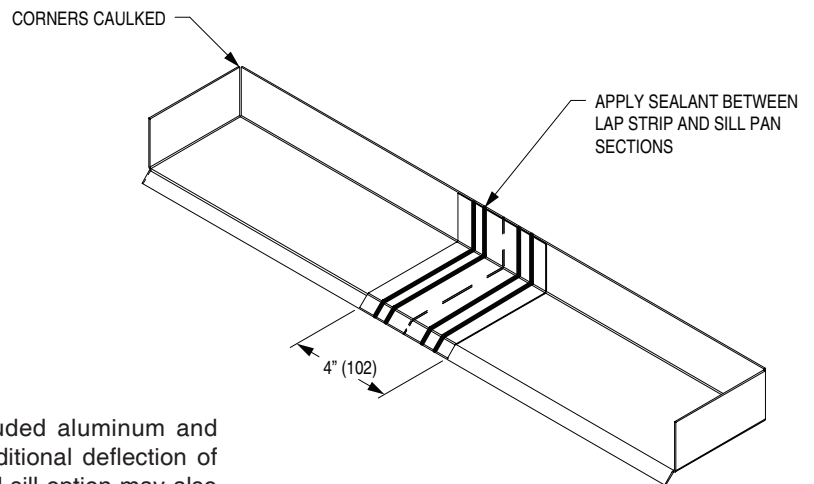
SILL PAN (Side View)

*Shipped in sections for multiple section width louvers where necessary.

APPLICATION:

Sill extensions are available on all Nailor extruded aluminum and formed steel louver models and can provide additional deflection of water away from the louver opening. An extended sill option may also provide a transition between the louver and adjacent structures.

NOTES:

1. The finish will match the louver.
2. When ordered, sill extensions are shipped loose for field installation.
3. Customization available upon request.

MATERIALS:

1. **ESI** Extended Sill 6063-T6 0.081" (2.1) thick extruded aluminum.
2. **PASI** Extended Sill 5052-H32 0.060" (1.5) thick formed aluminum

SCHEDULE TYPE:
PROJECT:
ENGINEER:
CONTRACTOR:

Dimensions are in inches (mm).

DATE
B SERIES
SUPERSEDES
DRAWING NO.

1 - 29 - 26

ACC-ESI

New

ACC-ESI



Slate Blue **LF01**



Medium Bronze **LF02**



Sandstone **LF03**



Light Gray **LF04**



Charcoal **LF05**

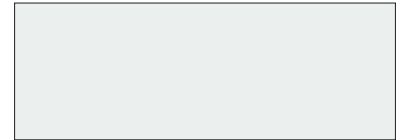

Bone White **LF06**



Western Tan **LF07**

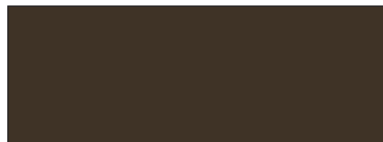

Architectural Bronze **LF08**



Regal Blue **LF09**



Forest Green **LF10**



Surrey Beige **LF11**



Royal Brown **LF12**



Barn Red **LF13**

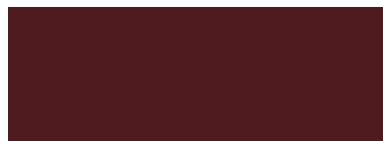

Burgundy **LF14**



Clay **LF15**



Almond **LF16**



Coastal White **LF17**



Vista Green **LF18**



Black **LF19**



Gloss Black **LF20**



Campus Green **LF21**

Nailor offers 21 standard paint colors selected for architectural exterior use which meet or exceed AAMA specifications and performance requirements for color retention, chalk resistance, gloss retention, erosion, corrosion and chemical resistance as well as dry film thickness and hardness. Our state-of-the-art powder coat system provides an environment friendly finishing solution with more uniform coverage and coating thickness. The result is an exceptional finish that better resists scratching, fading and general wear. Additional liquid coat facilities for special requirements complete our ability to provide unmatched beauty and durability for any application.

Custom color matching is also available upon request. Contact your local Nailor representative.

Available Finishes

FINISH TYPE	DESCRIPTION	STANDARD WARRANTY
Fluoropolymer Powder Coat AAMA 2605-Superior Finish (AKA: Powdura® 5000, Corafalon® Powder, Interpon® D3000-Fluoromax, IFS 500FP)	"Ultimate" - A next generation hyper durable powder coating, based on FEVE fluoropolymer resins and ceramic pigmentation that the industry has acknowledged as the foundation for superior performance coatings. They provide a hard surface that is resistant to scratching and scuffing, with superior color and gloss retention, when applied to a variety of exterior architectural applications. This technology represents the "ultimate" in environmentally friendly finishes, with Zero-VOC emissions. A superior alternative to traditional 70% Kynar 500® / Hylar 500® PVDF fluoropolymer liquid coatings.	10 years (Consult Nailor for availability of extended warranty)
High Performance Powder Coat AAMA 2604 - High Performance Finish (AKA: Powdura® 4000, Envirocron® Ultra Durable Powder, Dynadure™ 400, Interpon® D2000, IFS 400SD)	"Better" - A high performance polyester powder coating, based on "super durable" resins that utilize infrared reflective pigments, which provides excellent resistance to outdoor weathering. A harder and more environmentally friendly coating than other liquid paint counterparts and with Zero-VOC emissions. A good alternative to 50% Kynar 500® / Hylar 5000® liquid coatings.	5 years
Durable Powder Coat AAMA 2603 - Pigmented Organic Coatings (AKA: Powdura® 3000, Envirocron® Durable Powder, Dynadure™ 300, Interpon® D1000, IFS 300SP)	"Good" - A durable powder coat based on thermosetting polyester resin technology. Provides a good economical combination of physical and chemical resistance properties. Environmentally superior to liquid spray paints and Zero – VOC emissions.	1 year
Clear Anodize 215-R1 AA-M10C22A41 (0.7 mil. min.)	Architectural Class I. Clear, colorless and hard oxide aluminum coating that resists weathering and chemical attack. Recommended for severely corrosive and abrasive atmospheric exposure.	5 years
Clear Anodize 204-R1 AA-M10C22A31 (0.4 - 0.7 mil.)	Architectural Class II. Clear, colorless and hard oxide aluminum coating that resists weathering and chemical attack. Recommended for normal weather exposure.	1 year
Color Anodize AA-M10C22A44 (0.7 mil. min.)	Architectural Class I. "Two-step" aluminum coating process. Following a standard anodizing procedure, a second electrolytic process deposits colored metallic pigments which penetrate the aluminum oxide pores, producing a corrosion resistant, colorfast finish. Available in light, medium, dark bronze and black.	5 years
Prime Coat	Prime coat provides a stable base for painting of louvers in the field. Surface pretreatment includes degreasing and a chemical cleaning before an epoxy prime coat is applied. Finish coat should be field applied as soon as possible for best adhesion, after a thorough cleaning for dust etc. that can contaminate the final finish and cause premature flaking or peeling.	N/A

Paint finish warranties are not applicable to steel products.

Powdura® is a registered trademark of The Sherwin-Williams Company.

Corafalon® and Envirocron® are registered trademarks of PPG Industries Ohio, Inc.

Interpon® is a registered trademark of Akzo Nobel Powder Coatings Ltd.

Kynar 500® is a registered trademark of Arkema, Inc.

Hylar 5000® is a registered trademark of Solvay Solexis, Inc.