



DYNAMIC MULTI-BLADE FIRE DAMPER
 FOR USE IN DYNAMIC OR STATIC SYSTEMS
 1 1/2 HR. LABEL • VEE BLADE
 MODELS: D1250 AND D1251 (TYPE A)



QUALIFICATIONS:

- **UL 555 & CAN/ULC-S112 CLASSIFIED DYNAMIC FIRE DAMPER** 1 1/2 hr. Label (File # R9492).
- **Meets NFPA 80, 90A and 101 as well as IBC and NBC (Canada) Building Code requirements.**
- **City of New York Board of Standards and Appeals. Cal. No. 460-88-SA.**
- **California State Fire Marshal: Fire Damper Listing No. 3225-0935:0101.**
- **Maximum velocity: 4000 fpm @ 4" w.g. (20 m/s @ 1 kPa).**

D1250 Series Dampers are ideal for applications where building codes require a fire damper for the protection of ductwork penetrations in walls or floors that have a fire resistance rating of up to 2 hours. The D1250 Series has been designed and tested to offer a rugged cost effective multi-blade damper well suited to the majority of commercial applications. Parallel blade action assures closure in dynamic (fans on) systems.

The design features the industry proven over-center knee lock with high torque spring/fusible link closure. UL approved for installation with airflow in either direction and inverted mounting supplied as standard with an internal crank arm and locking screw which holds the damper in the fully open position, but may also be used for system balancing if required.

STANDARD CONSTRUCTION:

- Frame:** 5" x 7/8" x 16 ga. (127 x 22 x 1.6) galvanized steel hat channel.
- Blades:** 6" (152) wide on 5 1/2" (140) centers. 16 ga. (1.6) galvanized steel vee groove design. Parallel action.
- Linkage:** Concealed in frame. 12 ga. (2.7) plated steel.
- Bearings:** 1/2" (13) dia. self-lubricating oilite bronze.
- Axles:** 1/2" (13) dia. plated steel bolted to blades.
- Jackshaft:** 1/2" (13) dia. cadmium plated steel. Internal locking quadrant is factory installed.
- Fusible Link:** 165°F (74°C) standard. 212°F (100°C) available.

Sizes (Duct W x H):

Velocity/ Pressure Rating	Minimum		Maximum			
	Single Sect.	Single Section		Multiple Section		
	Vert./Horiz.	Vertical	Horizontal	Vertical	Horizontal	
24	8" x 8" (203 x 203)	36" x 48" (914 x 1219)	30" x 40" (762 x 1016)	72" x 48" (1829 x 1219) or 36" x 96" (914 x 2438)	60" x 40" (1524 x 1016) or 30" x 80" (762 x 2032)	
34, 44				—	—	

Notes: Dampers with duct heights less than 8" (203) require a Type 'B' sleeve enclosure (Model D1252). Units less than 8" (203) in width only, or in both width and height, require a Type 'C' enclosure (Model D1253).

BASE MODEL SELECTION:

- D1250** Less sleeve
- D1251** Standard factory sleeve 16" long x 20 ga. (406 x 1.0) (18 ga. for dampers over 84" [2134] in width).
- D1251** Non-standard sleeve. Specify _____ length _____ ga. Available up to 36" (914) dependent upon wall thickness and 10 through 20 ga. (3.5 through 1.0).

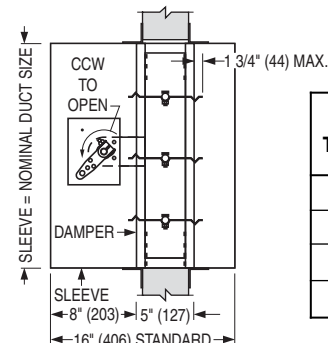
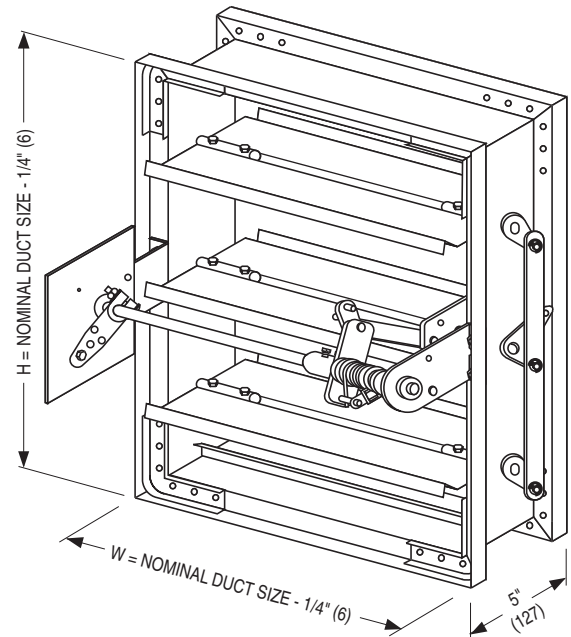

Wall Thickness	Minimum Sleeve Length
4 (102)	16 (406)
8 (203)	20 (508)
12 (305)	24 (610)
16 (406)	28 (711)

DYNAMIC VELOCITY/PRESSURE RATING:

- 24** 2000 fpm @ 4" w.g. (Standard)
- 34** 3000 fpm @ 4" w.g. } (Optional)
- 44** 4000 fpm @ 4" w.g. }

OPTIONS:

- SMP** Side mounting plate
- MLS-300** Position indicator switch package
- QS1** Quick-set retaining angle (one side)
- QS2** Quick-set retaining angles (two sides)
- TDF1** Flange (one end)
- TDF2** Flange (both ends)
- Special features** _____

SCHEDULE TYPE:

PROJECT:

ENGINEER:

CONTRACTOR:

For installation instructions, see IOM-MBFDINST.
 Dimensions are in inches (mm).

DATE	B SERIES	SUPERSEDES	DRAWING NO.
4 - 28 - 14	D1200	11 - 22 - 11	D1250-1



DYNAMIC MULTI-BLADE FIRE DAMPER
 FOR USE IN DYNAMIC OR STATIC SYSTEMS
 1 1/2 HR. LABEL • VEE BLADE
MODEL: D1252 (TYPE B)



FOR DUCTS UNDER 8" (203) IN HEIGHT AND 8" (203) OR MORE IN WIDTH

QUALIFICATIONS:

- **UL 555 & CAN/ULC-S112 CLASSIFIED DYNAMIC FIRE DAMPER** 1 1/2 hr. Label (File # R9492).
- **Meets NFPA 80, 90A and 101 as well as IBC and NBC (Canada) Building Code requirements.**
- **City of New York Board of Standards and Appeals. Cal. No. 460-88-SA.**
- **California State Fire Marshal: Fire Damper Listing No. 3225-0935:0101.**
- **Maximum velocity: 4000 fpm @ 4" w.g. (20 m/s @ 1 kPa).**

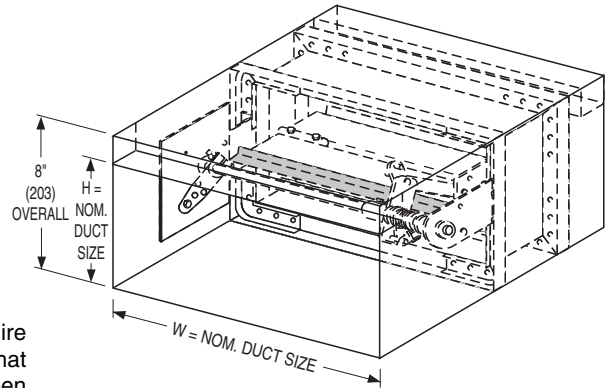

D1250 Series Dampers are ideal for applications where building codes require a fire damper for the protection of ductwork penetrations in walls or floors that have a fire resistance rating of up to 2 hours. The D1250 Series has been designed and tested to offer a rugged cost effective multi-blade damper well suited to the majority of commercial applications. Parallel blade action assures closure in dynamic (fans on) systems.

The design features the industry proven over-center knee lock with high torque spring/fusible link closure. UL approved for installation with airflow in either direction and inverted mounting. Supplied as standard with an internal crank arm and locking screw which holds the damper in the fully open position, but may also be used for system balancing if required.

STANDARD CONSTRUCTION:

- Frame:** 5" x 7/8" x 16 ga. (127 x 22 x 1.6) galvanized steel hat channel.
- Blades:** 6" (152) wide on 5 1/2" (140) centers. 16 ga. (1.6) galvanized steel vee groove design.
- Linkage:** Concealed in frame. 12 ga. (2.7) plated steel.
- Bearings:** 1/2" (13) dia. self-lubricating oilite bronze.
- Axles:** 1/2" (13) dia. plated steel bolted to blades.
- Jackshaft:** 1/2" (13) dia. cadmium plated steel. Internal locking quadrant is factory installed.
- Fusible Link:** 165°F (74°C) standard. 212°F (100°C) available.

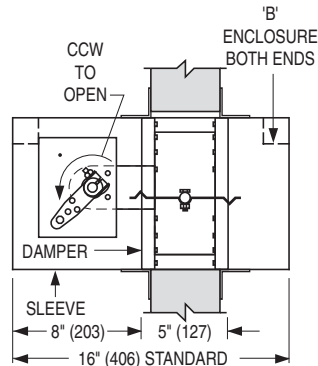

Wall Thickness	Minimum Sleeve Length
4 (102)	16 (406)
8 (203)	20 (508)
12 (305)	24 (610)
16 (406)	28 (711)

Sizes (Duct W x H):

Velocity/ Pressure Rating	Minimum		Maximum			
	Single Sect.	Single Section		Multiple Section		
	Vert./Horiz.	Vertical	Horizontal	Vertical	Horizontal	
24	8" x 4" (203 x 102) Overall damper height is 8" (203).	36" x 7 1/2" (914 x 191)	30" x 7 1/2" (762 x 191)	72" x 7 1/2" (1829 x 191)	60" x 7 1/2" (1524 x 191)	
34, 44				—	—	

Notes: Dampers with duct heights less than 8" (203) in width only, or in both width and height, require a Type 'B' sleeve enclosure (Model D1252). Duct sizes less than 8" (203) in width require a Type 'C' enclosure (Model D1253).

BASE MODEL SELECTION:

- D1252** Standard factory sleeve 16" long x 20 ga. (406 x 1.0).
- D1252** Non-standard sleeve. Specify _____ length _____ ga. Available up to 36" (914) dependent upon wall thickness and 10 through 20 ga. (3.5 through 1.0).

DYNAMIC VELOCITY/PRESSURE RATING:

- 24** 2000 fpm @ 4" w.g. (Standard)
- 34** 3000 fpm @ 4" w.g. } (Optional)
- 44** 4000 fpm @ 4" w.g. }

OPTIONS:

- MLS-300** Position indicator switch package
- QS1** Quick-set retaining angle (one side)
- QS2** Quick-set retaining angles (two sides)
- Special features** _____

SCHEDULE TYPE:

PROJECT:

ENGINEER:

CONTRACTOR:

For installation instructions, see IOM-MBFDINST.
 Dimensions are in inches (mm).

DATE	B SERIES	SUPERSEDES	DRAWING NO.
4 - 28 - 14	D1200	11 - 22 - 11	D1250-2



DYNAMIC MULTI-BLADE FIRE DAMPER
 FOR USE IN DYNAMIC OR STATIC SYSTEMS
 1 1/2 HR. LABEL • VEE BLADE • ROUND DUCT
 CONNECTION
MODEL: D1253 (TYPE C SLEEVE ENCLOSURE)



QUALIFICATIONS:

- **UL 555 & CAN/ULC-S112 CLASSIFIED DYNAMIC FIRE DAMPER** 1 1/2 hr. Label (File # R9492).
- **Meets NFPA 80, 90A and 101 as well as IBC and NBC (Canada) Building Code requirements.**
- **City of New York Board of Standards and Appeals. Cal. No. 460-88-SA.**
- **California State Fire Marshal: Fire Damper Listing No. 3225-0935:0101.**
- **Maximum velocity: 4000 fpm @ 4" w.g. (20 m/s @ 1 kPa).**

D1250 Series Dampers are ideal for applications where building codes require a fire damper for the protection of ductwork penetrations in walls or floors that have a fire resistance rating of up to 2 hours. The D1250 Series has been designed and tested to offer a rugged cost effective multi-blade damper well suited to the majority of commercial applications. Parallel blade action assures closure in dynamic (fans on) systems.

The design features the industry proven over-center knee lock with high torque spring/fusible link closure. UL approved for installation with airflow in either direction and inverted mounting. Supplied as standard with an internal crank arm and locking screw which holds the damper in the fully open position, but may also be used for system balancing if required.

STANDARD CONSTRUCTION:

- Frame:** 5" x 7/8" x 16 ga. (127 x 22 x 1.6) galvanized steel hat channel.
- Blades:** 6" (152) wide on 5 1/2" (140) centers. 16 ga. (1.6) galvanized steel vee groove design. Parallel action.
- Linkage:** Concealed in frame. 12 ga. (2.7) plated steel.
- Bearings:** 1/2" (13) dia. self-lubricating oilite bronze.
- Axles:** 1/2" (13) dia. plated steel bolted to blades.
- Jackshaft:** 1/2" (13) dia. cadmium plated steel. Internal locking quadrant is factory installed.
- Fusible Link:** 165°F (74°C) standard. 212°F (100°C) available.

Round Duct Connection Sizes (Duct Dia.):

Velocity/ Pressure Rating	Minimum	Maximum			
		Single Section		Multiple Section	
	Vert./Horiz.	Vertical	Horizontal	Vertical	Horizontal
24	4" (102) dia. Overall damper size is 8" x 8" (203 x 203).	34" (864) dia.	28" (711) dia.	46" (1168) dia.	38" (965) dia.
34, 44				—	—

Notes: Dampers with duct heights less than 8" (203) in width only, or in both width and height, require a Type 'B' sleeve enclosure (Model D1252). Duct sizes less than 8" (203) in width require a Type 'C' enclosure (Model D1253).

BASE MODEL SELECTION:

- D1253** Standard factory sleeve 16" long x 20 ga. (406 x 1.0).
- D1253** Non-standard sleeve. Specify _____ length _____ ga. Available up to 36" (914) dependent upon wall thickness and 10 through 20 ga. (3.5 through 1.0).

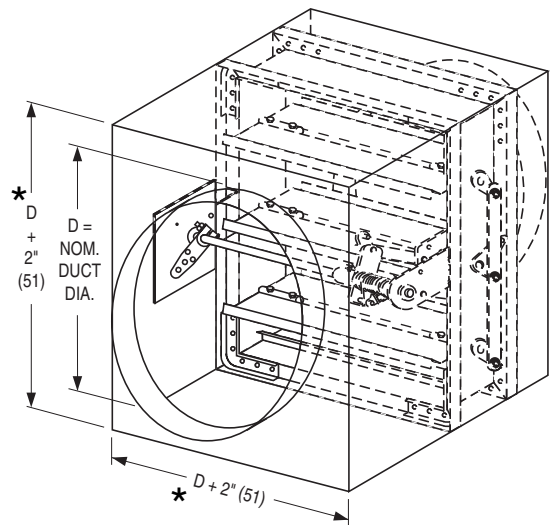

* or 8" (203) min.

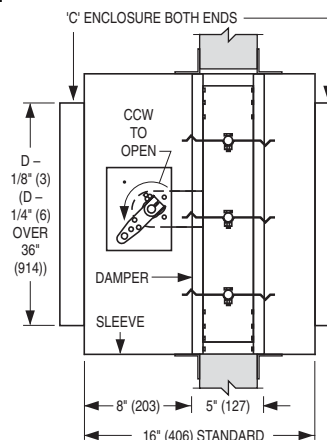

Wall Thickness	Minimum Sleeve Length
4 (102)	16 (406)
8 (203)	20 (508)
12 (305)	24 (610)
16 (406)	28 (711)

DYNAMIC VELOCITY/PRESSURE RATING:

- 24** 2000 fpm @ 4" w.g. (Standard)
- 34** 3000 fpm @ 4" w.g. } (Optional)
- 44** 4000 fpm @ 4" w.g. }

OPTIONS:

- MLS-300** Position indicator switch package
- QS1** Quick-set retaining angle (one side)
- QS2** Quick-set retaining angles (two sides)
- Special features** _____

SCHEDULE TYPE:

PROJECT:

ENGINEER:

CONTRACTOR:

For installation instructions, see IOM-MBFDINST.
 Dimensions are in inches (mm).

DATE	B SERIES	SUPERSEDES	DRAWING NO.
4 - 28 - 14	D1200	11 - 22 - 11	D1250-3



DYNAMIC MULTI-BLADE FIRE DAMPER
 FOR USE IN DYNAMIC OR STATIC SYSTEMS
 1 1/2 HR. LABEL • VEE BLADE • SQUARE,
 RECTANGULAR OR OVAL DUCT CONNECTION
MODEL: D1253 (TYPE C SLEEVE ENCLOSURE)



QUALIFICATIONS:

- **UL 555 & CAN/ULC-S112 CLASSIFIED DYNAMIC FIRE DAMPER**
1 1/2 hr. Label (File # R9492).
- **Meets NFPA 80, 90A and 101 as well as IBC and NBC (Canada)**
Building Code requirements.
- **City of New York Board of Standards and Appeals. Cal. No. 460-88-SA.**
- **California State Fire Marshal: Fire Damper Listing No. 3225-0935:0101.**
- **Maximum velocity: 4000 fpm @ 4" w.g. (20 m/s @ 1 kPa).**

D1250 Series Dampers are ideal for applications where building codes require a fire damper for the protection of ductwork penetrations in walls or floors that have a fire resistance rating of up to 2 hours. The D1250 Series has been designed and tested to offer a rugged cost effective multi-blade damper well suited to the majority of commercial applications. UL approved for installation with airflow in either direction and inverted mounting. Supplied as standard with an internal crank arm and locking screw which holds the damper in the fully open position, but may also be used for system balancing if required.

STANDARD CONSTRUCTION:

- Frame:** 5" x 7/8" x 16 ga. (127 x 22 x 1.6) galvanized steel hat channel.
- Blades:** 6" (152) wide on 5 1/2" (140) centers. 16 ga. (1.6) galvanized steel vee groove design. Parallel action.
- Linkage:** Concealed in frame. 12 ga. (2.7) plated steel.
- Bearings:** 1/2" (13) dia. self-lubricating oilite bronze.
- Axles:** 1/2" (13) dia. plated steel bolted to blades.
- Jackshaft:** 1/2" (13) dia. cadmium plated steel.
Internal locking quadrant is factory installed.
- Fusible Link:** 165°F (74°C) standard. 212°F (100°C) available.

Square, Rectangular or Oval Duct Connection Sizes (Duct W x H):

Velocity/ Pressure Rating	Minimum		Maximum			
	Single Sect.	Single Section		Multiple Section		
	Vert./Horiz.	Vertical	Horizontal	Vertical	Horizontal	
24	4" x 4" (102 x 102). Overall damper size is 8" x 8" (203 x 203) min.	34" x 46" (864 x 1168).	28" x 38" (711 x 965)	70" x 46" (1778 x 1168) or 34" x 94" (864 x 2388).	58" x 38" (1473 x 965) or 28" x 78" (711 x 1981).	
34, 44				—	—	

Notes: Dampers with duct heights less than 8" (203) in width only, or in both width and height, require a Type 'B' sleeve enclosure (Model D1252). Duct sizes less than 8" (203) in width require a Type 'C' enclosure (Model D1253).

BASE MODEL SELECTION:

- D1253** Standard factory sleeve 16" long x 20 ga. (406 x 1.0) (18 ga. for dampers over 84" [2134] in width).
- D1253** Non-standard sleeve. Specify _____ length _____ ga. Available up to 36" (914) dependent upon wall thickness and 10 through 20 ga. (3.5 through 1.0).

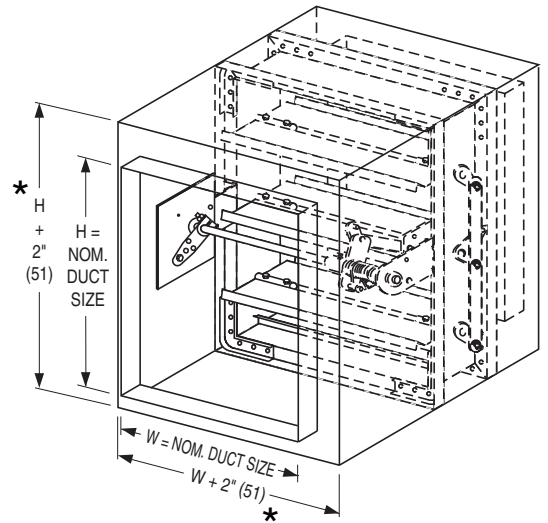

* or 8" (203) min.

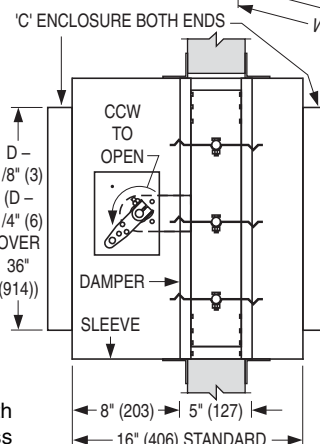
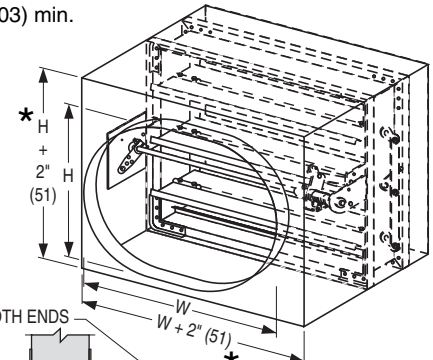

Wall Thickness	Minimum Sleeve Length
4 (102)	16 (406)
8 (203)	20 (508)
12 (305)	24 (610)
16 (406)	28 (711)

DYNAMIC VELOCITY/PRESSURE RATING:

- 24** 2000 fpm @ 4" w.g. (Standard)
- 34** 3000 fpm @ 4" w.g. } (Optional)
- 44** 4000 fpm @ 4" w.g. }

OPTIONS:

- MLS-300** Position indicator switch package
- QS1** Quick-set retaining angle (one side)
- QS2** Quick-set retaining angles (two sides)
- Special features** _____

For installation instructions, see IOM-MBFDINST.
 Dimensions are in inches (mm).

SCHEDULE TYPE:	DATE	B SERIES	SUPERSEDES	DRAWING NO.
PROJECT:	4 - 28 - 14	D1200	11 - 22 - 11	D1250-4
ENGINEER:				
CONTRACTOR:				

**"QUICK-SET" RETAINING ANGLES BOTH SIMPLIFY AND SPEED INSTALLATION,
SAVING BOTH TIME AND MONEY.**

BENEFITS:

- One piece angles are fastened together in the corners. Only two sets of angles to handle per damper (rather than four separate angles per side).
- Angles are shipped with damper - no sorting or matching.
- Provided with pre-drilled fastening holes on 2" (51) centers to ensure correct angle/sleeve attachment.
- Factory fabricated by Nailor to suit the individual fire damper.
- Reduced cost when compared to conventional retaining angles.
- Dampers can ship directly to the job site complete with all necessary installation sheet metal hardware (saves on double handling at contractor's shop).
- Help ensure a correct installation as per U.L. approved installation instructions.

The majority of installing contractors view fire damper installation as a costly time consuming and troublesome procedure. Eight conventional angles must be custom fabricated for each damper either in a sheet metal shop or at the job site and sized to suit each individual damper. Invariably, they are mislaid or lost and must be matched to each factory supplied damper.

The Nailor "Quick-Set" solution solves the majority of problems. They are pre-formed to fit and ship with the individual damper for ultimate convenience. "Quick-Set" angles are supplied with correctly spaced pre-drilled screw-holes to ensure a quick, easy and accurate installation for all integral sleeve Nailor fire and combination fire/smoke dampers - no measuring required.

"Quick-Set" retaining angles provide the "complete" installation package. Simple, fast, convenient.

MODELS:

Nailor "Quick-Set" retaining angles are an accessory option for all dampers ordered with factory sleeves.

QS2: Two sides (pair). For standard installations where angles are installed on both sides of the fire partition.

QS1: One side (single set). For use in single side retaining angle installations and with grille mount and "out of wall" damper models.

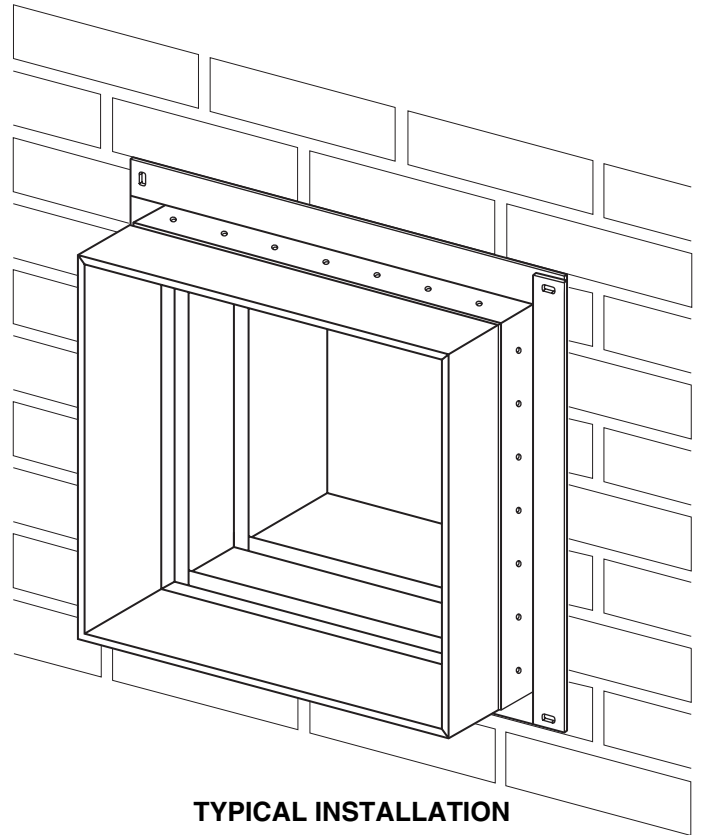

TYPICAL INSTALLATION

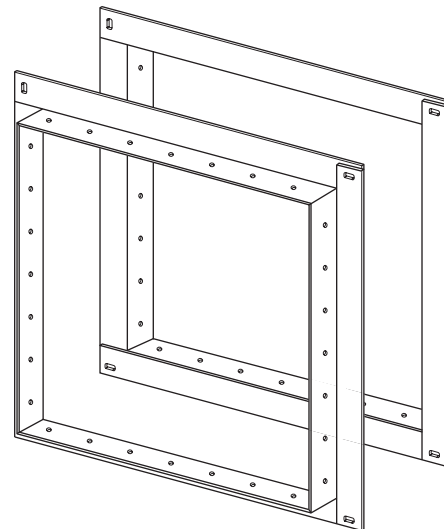

**TYPICAL PAIR OF PRE-ASSEMBLED
QUICK-SET' RETAINING ANGLES**

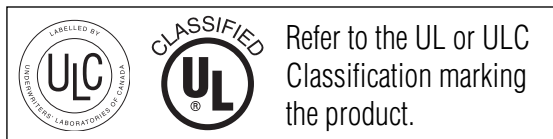

SCHEDULE TYPE:	Page 1 of 2			
PROJECT:	Dimensions are in inches (mm).			
ENGINEER:	DATE	B SERIES	SUPERSEDES	DRAWING NO.
CONTRACTOR:	2 - 26 - 09	FD-ACC	6 - 5 - 03	QSRA

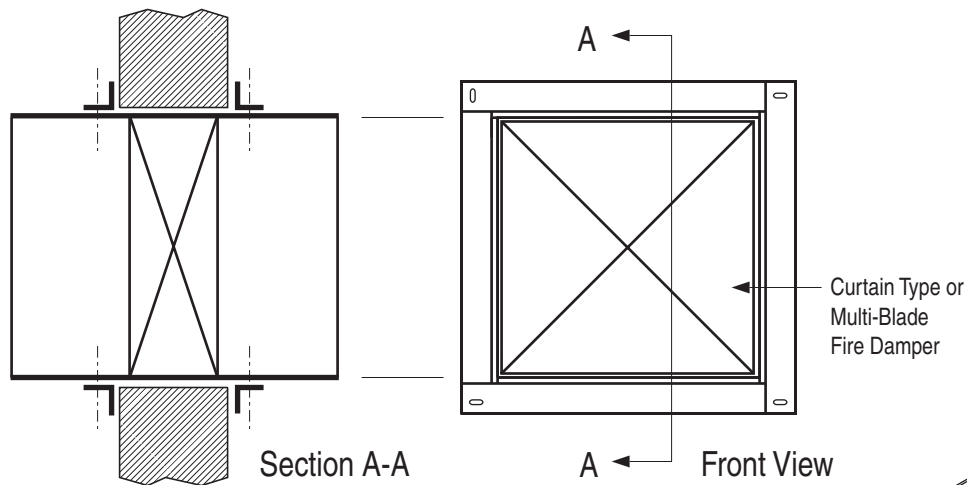

FIGURE 1. TYPICAL TWO SIDED INSTALLATION.

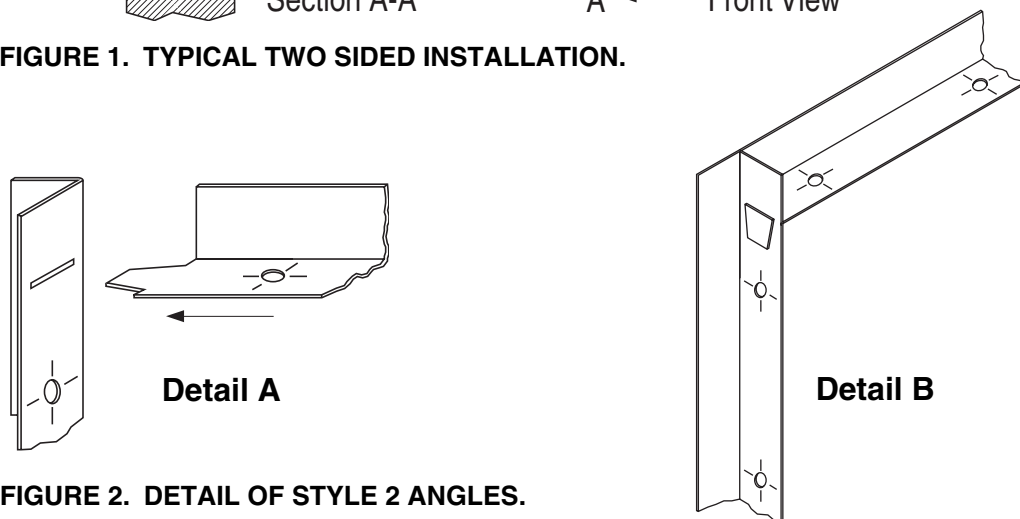

FIGURE 2. DETAIL OF STYLE 2 ANGLES.

APPLICATION:

The Nailor Quick-Set Retaining Angle System may be used in lieu of conventional retaining angles on all Nailor Fire and Combination Fire/Smoke Dampers.

Quick-Set angles are supplied in one of two styles, dependent upon fire resistance label, damper size and installation method.

Style 1: 1 1/2" x 1 1/2" x 20 ga. (38 x 38 x 1.0) Four sides are connected together with rivets in three corners.

Standard for the majority of applications with the following limitations:

- 1 1/2 hour label fire dampers.
- Maximum Size: 36" x 36" (914 x 914)
- Two sided installation only

Style 2: 1 1/2" x 1 1/2" x 16 ga. (38 x 38 x 1.6) Slot and tab design. The retaining angle assembly for each side has four angles, each with a tab end and a slot end (Detail A).

The tabs are to be inserted into the slots and knocked down either before or after fastening to the sleeve (Detail B).

- 1 1/2 or 3 hour label fire dampers
- Maximum Size: 90" x 48" (2286 x 1219) or 48" x 90" (1219 x 2286)
- Single side (1 1/2 hour only. Refer to Single Side Retaining Angles Supplementary Installation Instructions for size limitations) or two sided installation

Refer to the Following Installation Instructions:

Quick-Set Retaining Angles	FDQSRA
Curtain Type Fire Dampers (D)0100 & (D)0500	FDINST
Curtain Type Fire Dampers 0200 & 0500 Thinline	FDTINST
Multi-Blade Fire Dampers 1200 & 1250	MBFDINST
Combination Fire/Smoke Dampers 1220	1220INST
Combination Fire/Smoke Dampers 1270	1270INST
Single Side Retaining Angles	FDSSRAINST

SCHEDULE TYPE:	Page 2 of 2			
PROJECT:	Dimensions are in inches (mm).			
ENGINEER:	DATE	B SERIES	SUPERSEDES	DRAWING NO.
CONTRACTOR:	2 - 26 - 09	FD-ACC	5 - 5 - 03	QSRA

PERFORMANCE DATA:

MODEL SERIES: D1250 - 1 1/2 HOUR LABEL

PRESSURE DROP:

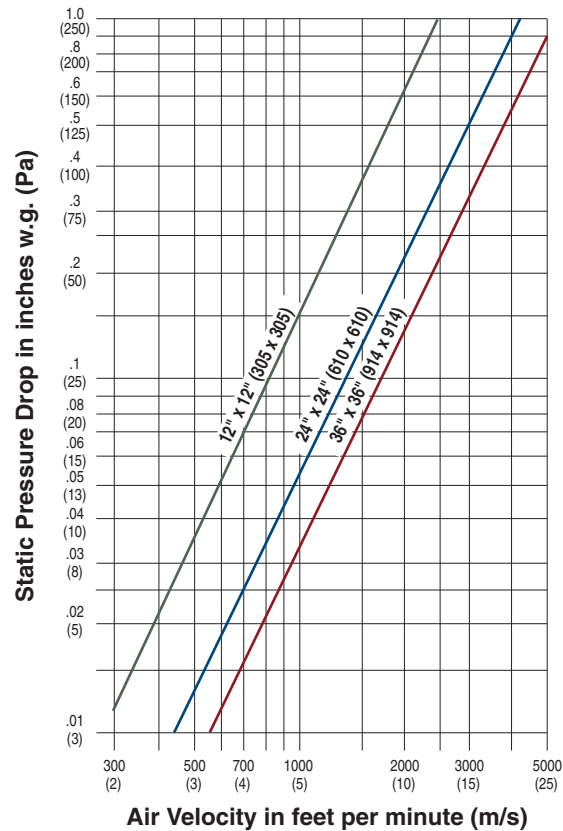

D1250 Series Maximum Performance Ratings	
UL 555 Fire Rating	1 1/2 Hour
Maximum Velocity	4000 fpm (20 m/s)
Maximum Pressure	4 in. w.g. (1 kPa)

Pressure drop tested per AMCA Standard 500-D, Figure 5.3.
Data corrected to standard air density of 0.075 lbs/ft.³.

HOW TO SPECIFY

SUGGESTED SPECIFICATION:

Provide and install, as shown on plans and/or schedules, Multi-Blade Dynamic Fire Dampers as manufactured by Nailor Industries, Inc. which meet or exceed the following criteria: Fire dampers shall meet the requirements of NFPA 80, 90A and 101 and shall be manufactured, tested and labeled in accordance with UL 555. Each damper shall bear a UL fire resistance rating label of 1 1/2 hours and in addition, a label verifying the airflow and closure pressure ratings of **(specifier select rating)** 2000 fpm (10 m/s) **or** 3000 fpm (15 m/s) **or** 4000 fpm (20 m/s), at 4" w.g. (1 kPa) static pressure differential, as established by the Dynamic Closure Test. Each fire damper shall also be marked with the words "For use in dynamic systems". Dampers marked "For use in static systems only" are not acceptable.

Frame shall be constructed of 16 ga. (1.6) galvanized steel hat channel with mitered corners reinforced with die-formed corner gussets for strength. Blades shall be of vee-groove design, 16 ga. (1.6) galvanized steel on 5 1/2" (140) centers, and shall be parallel configuration. Blade axes shall be 1/2" (13) dia. plated steel, double bolted at each end of blade to ensure positive locking connection. Hex, square friction-fit or press-fit axes are not acceptable. Bearings shall be self-lubricating oilite bronze type. Blade linkage shall be zero-maintenance, concealed in frame, out of airstream.

Each fire damper shall be complete with a **(specifier select temperature)** 165°F (74°C) **or** 212°F (100°C) UL Listed fusible link that will cause the damper to close and lock in closed position by means of an over center/knee lock linkage for assured closure. Fire dampers shall each include a steel sleeve of appropriate length/gauge as field verified by contractor, with Nailor 'Quick-Set' retaining angles supplied by damper manufacturer to ensure proper installation in accordance with damper manufacturer's instructions. Each damper shall be supplied with an internal manual quadrant(s) for setting and locking of blades in desired position. Contractor shall provide and install an access door at each fire damper, of appropriate size to allow for inspection, testing and fusible link replacement. Data submitted for approval shall include confirmation of UL qualifications in addition to manufacturer's installation instructions. Each shipment of fire dampers shall include same installation instructions. Standard of acceptance shall be Nailor Model Series D1250.

Dampers are an essential part of the fire protection system in a building. The NFPA recommends that fire dampers be tested periodically to verify the operational abilities of each installed damper. See NFPA 80, *Standard for Fire Doors and Other Opening Protectives*, for Operational and Periodic Inspection and Testing details.

CAUTION:

High torque helical spring under tension, ensure HVAC fans are turned off. Testing spring assisted fire dampers under airflow conditions is **NOT RECOMMENDED** and may severely damage or destroy ductwork. Use protective eyewear or safety glasses. Keep hands out of the blade path, as this can cause serious injury. Keep any hard objects or tools out of the blade path as they can damage the blades when closing.

Releasing of the fusible link

1. Using a suitable heat source, apply heat at a slightly higher temperature than the rating of the fusible link until the link melts. When applying the heat to the fusible link position the heat source in a manner so no heat is directed towards the spring as the excessive heat can negatively affect the spring performance.

AS SOON AS THE LINK HAS MELTED, THE SPRING WILL FORCE THE BLADES TO CLOSE INSTANTANEOUSLY. THE BLADE PATH MUST BE KEPT CLEAR.

Reloading the spring assembly

2. Loosen the jackshaft from the bolt on crank arm quadrant, located on the jackshaft side opposite of the spring assembly (A). Do not remove the bolt completely. See Detail 1.

3. Attach a pair of vise grips on the jackshaft (B) and turn upwards until the two pins on the spring assembly are at a distance at which the new fusible link can be installed (C). This is approximately 90° of rotation. See Detail 2.

Note: On smaller size dampers, two vise grips may be required to open the damper. Use one vice grip to open as much as the duct free area will allow, then set the second vise grips on the jackshaft per above. Unlock the first set of vise grips, remove and turn the second set upwards as free area will allow. Repeat as necessary.

4. Place the new fusible link over the two pins on the spring assembly (making sure temperature rating is visible) and locate in the pin grooves (C). See Detail 2.

Required Items:

- (1) Protective eyewear or safety glasses
- (1) Pair of work gloves
- (1) Suitable heat source
- (2) Vise grips
- (1) 1/2" (13) wrench
- (1) Needle nose pliers
- (1) Replacement "Globe" Fusible link per damper section, of the same temperature rating as the original link.



Detail 1



Detail 2

5. Manually open the damper to 100% full open position (D). See Detail 3.
6. Tighten the bolt on the crank arm (E). See Detail 3.

Reopening spring assisted fire dampers may be extremely difficult and in some cases, impossible. If it is determined that the damper is impossible or impractical to test or reopen, a thorough examination of the blade path is required to ensure that nothing will prevent the damper from closing. Common obstructions include: racked damper frames, retaining angle installation screws, construction debris and contaminants.

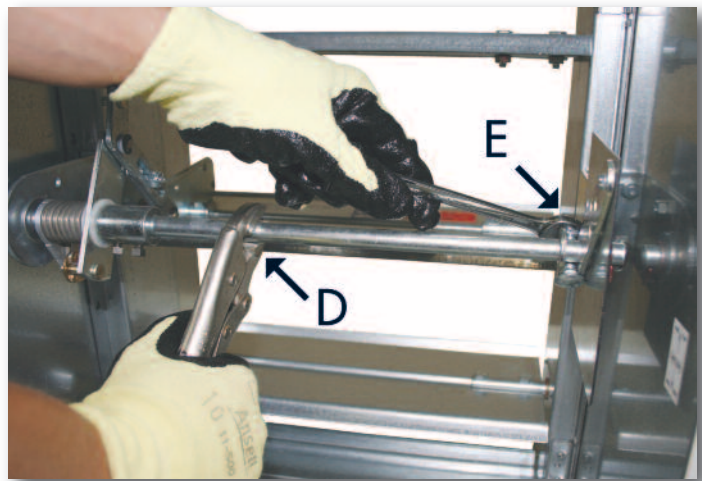

Detail 3

Periodic Inspection, Testing and Maintenance

Consult your local building code to verify whether there is a required maintenance and testing schedule. Most local jurisdictions reference NFPA 80 for Fire Dampers.

Per NFPA 80, each damper should be inspected 1 year after installation and then every 4 years, except for hospitals, where the frequency is every 6 years.

1. Remove any obstructions, dirt, rust, corrosion, or other observed conditions that could impede proper damper operation. Clean damper blades and other moving parts if necessary. Use of a mild detergent or solvents is recommended for any cleaning required.

2. Check closure springs. If damaged or defective, repair or replace.

3. Linkage and jackshaft bearing brackets should be lubricated with a dry lubricant (such as T.F.E. Dry Lube). Never use a regular lubricating oil on dampers, as it will attract dirt and grit. Blade linkage is concealed in the side jamb out of the airstream and is maintenance free. Bearings are self-lubricating oilite bronze (or stainless steel for -SS models).

4. If firing of the fusible link is not required by local code, cycle damper with its quadrant handle to verify that it fully opens and closes. HVAC fans should be shut down. Care should be exercised to ensure that such tests are performed safely and do not cause system damage.

5. All inspections and testing shall be documented indicating the location of the damper, date of inspection, name of inspector, deficiencies detected, and how deficiencies were corrected.

Receiving, Storage, Preparation

Upon delivery, inspect shipping containers and contents closely. Note any damages on freight carrier's delivery receipt.

Store dampers in a cool, dry and safe location in an orderly manner away from construction site, warehouse traffic, other materials, etc. Cover with plastic sheeting to protect from excessive moisture, dirt and debris.

Inspect dampers prior to installation. Dampers must be cleaned per procedures outlined in this document prior to installation if dirt, rust or corrosion is observed.

SPARE PARTS LIST		PART NUMBER
Fusible Links: Model 1200, 1250, 1290	165°F/74°C	B2-037
	212°F/100°C	B2-038

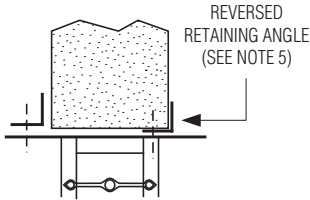

QUALIFICATIONS:

- **UL 555 & CAN/ULC-S112 CLASSIFIED FIRE DAMPER 1 1/2 or 3 hr. Label (File # R9492).**
- **Meets NFPA 80, 90A and 101 as well as IBC & NBC (Canada) Building Code requirements.**
- **California State Fire Marshal Listing No. 03225-0935:101.**
- **City of New York Board of Standards and Appeals. Cal. No. 460-88-SA (1250) and 366-03-M (1200).**

NOTES:

1. Installation shall be in accordance with the appropriate requirements of the National Fire Protection Association Standard NFPA 90A latest edition.
2. **Damper Sleeve:** Sleeve thickness must be equal to or thicker than the duct connected to it. Sleeve gauge requirements are listed in the SMACNA Fire, Smoke and Radiation Damper Installation Guide for HVAC Systems and in NFPA 90A. If a break-away style duct/sleeve connection is not used, damper sleeves up to 36" wide by 24" (914 x 610) high of not less than 16 gauge (1.61) coated steel, or larger sleeves of not less than 14 gauge (1.99) thick coated steel may be attached to the duct with screws or other types of mechanical fasteners. The maximum sleeve thickness for such rigid joints is 10 gauge (3.51) for coated steel. The connecting duct shall not be continuous thru the wall or floor opening but shall terminate at the sleeve. Sleeves shall extend a maximum of 6" (152) on either side of the wall or floor opening or 16" (406) on a side intended for use with an actuator and/or an access door. The sleeves may extend 16" (406) on each side for use with an actuator on one side and an access door on the other side.

3. Break-away duct/sleeve connections:

- a. Rectangular ducts must use one or more of the following connections if the gauge is less than the requirement in note 2 for rigid connections:

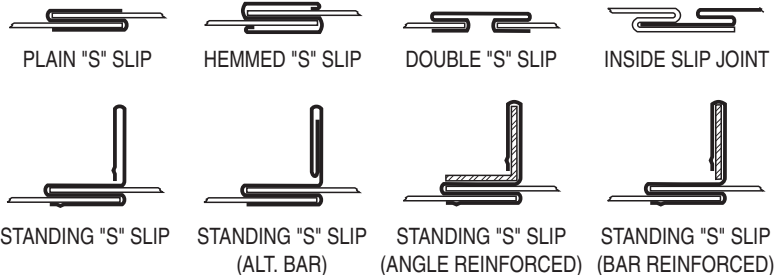
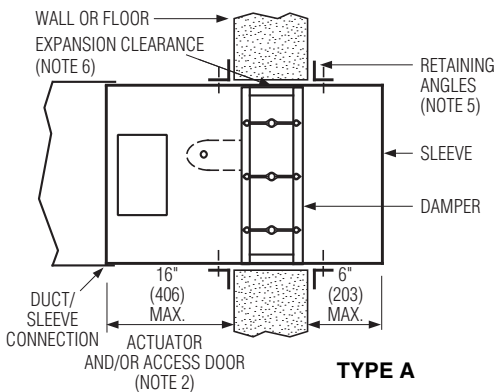

In addition:

- A maximum of two #10 sheet metal screws on each side and on the bottom, located in the center of the slip pocket and penetrating both sides of the slip pocket may be used.
- One of the above connections on the top and bottom joints with flat drive slip connections on the side joints may be used for dampers up to 20" (508) in height.

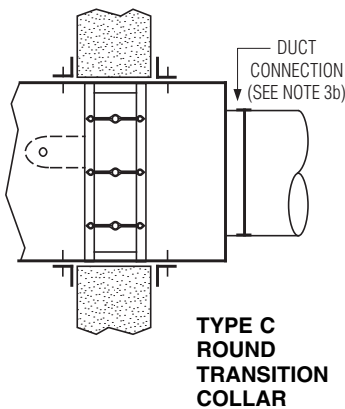

WARNING: STRONG SPRING UNDER TENSION ON ALL UNITS, KEEP HANDS CLEAR. IN ALL INSTALLATIONS ENSURE THAT OPERATING DRIVE SHAFT IS FREE FROM OBSTRUCTION TO ENSURE EASE OF OPERATION.

- b. Round or oval duct may be attached to the round or oval collar which is part of the damper/sleeve in the following manner:
 - Duct diameters 22" (559) and smaller must use three #10 sheet metal screws equally spaced around the circumference.
 - Duct diameters over 22" (559) up to and including 36" (914) may use five #10 sheet metal screws equally spaced around the circumference.
 - Duct diameters larger than 36" (914) wide or diameter may use eight #10 sheet metal screws equally spaced around the circumference.
- Note:** When optional sealing of these break-away connections is desired, the duct sealant shall be PA2084T Duct Sealant by Precision or water based DP1010 by Design Polymetrics.
- c. For the use of approved alternative Ductmate or TDC/TDF break-away connections, refer to the supplements noted on page 2.

Dimensions are in inches (mm).

4. Damper/sleeve attachment: Damper shall be secured to sleeve with 1/4" (6) long welds, 3/16" (4.76) steel rivets, 1/4" (6.35) dia. bolts and nuts, #8 sheet metal screws, or 3/16" (4.76) dia. buttonlocks on both sides at 6" (152) on center and a maximum of 4" (102) from the corners of the damper on all four sides. For field assembled sleeves, the inner dimensions of the sleeve shall be equal to the outer dimensions of the damper.

5. Retaining angles shall be a minimum of 1 1/2" x 1 1/2" x 16 gauge (38 x 38 x 1.61) for dampers up to 90" (2286) in width and up to 90" (2286) in height. For dampers exceeding these dimensions, the angles shall be a minimum of 2" x 2" x 10 gauge (51 x 51 x 3.51). Secure the retaining angles to the sleeve with 1/2" (12.7) long welds, 1/4" (6.35) dia. bolts and nuts, 3/16" (4.76) dia. steel rivets or #8 sheet metal screws 8" (203) on center and 2" (51) maximum from corner of sleeve on all four sides. The retaining angles must lap the structural opening by 1" (25.4) minimum. When the ductwork terminates at the wall or floor, the retaining angles may be turned inwards, providing the opening size is increased by an amount equal to twice the combined thickness of the angle and the height of the screw or bolthead to maintain the required expansion clearance. Field fabricated retaining angles are not to be mechanically fastened at the corners.

6. Expansion clearance between the sleeve and wall or floor shall be a minimum of 1/8" per foot (3.18 per 305) of width or height of the sleeve. The maximum size of the opening shall be 2" (50.8) larger in either dimension than the allowable minimum size. For example; a sleeve dimension of 36" x 36" (914 x 914) shall have an opening size of 36 3/8" x 36 3/8" (924 x 924) minimum and 38 3/8" x 38 3/8" (975 x 975) maximum.

7. Maximum Size Limitations: The maximum Type A fire damper sizes are as follows:

Model Series			Single Section	Multiple Section
D1200 (Dynamic)	Vertical	(1 1/2 hr. label)	36" x 48" (914 x 1219)	72" x 96" (1829 x 2438) or 144" x 48" (3658 x 1219)
	Horizontal	(1 1/2 hr. label)	32" x 48" (813 x 1219)	64" x 96" (1626 x 2438) or 128" x 48" (3251 x 1219)
1200 (Static)	Vertical	(1 1/2 hr. label)	36" x 48" (914 x 1219)	144" x 96" (3658 x 2438)
	Horizontal	(1 1/2 hr. label)	32" x 48" (813 x 1219)	144" x 96" (3658 x 2438)
D1200-3 (Dynamic)	Vertical	(3 hr. label)	36" x 48" (914 x 1219)	60" x 96" (1524 x 2438)*
	Horizontal	(3 hr. label)	32" x 48" (813 x 1219)	—
1200-3 (Static)	Vertical	(3 hr. label)	36" x 48" (914 x 1219)	120" x 96" (3048 x 2438)*
	Horizontal	(3 hr. label)	32" x 48" (813 x 1219)	—
D1250 (Dynamic)	Vertical	(1 1/2 hr. label)	36" x 48" (914 x 1219)	72" x 48" (1829 x 1219) or 36" x 96" (914 x 2438)
	Horizontal	(1 1/2 hr. label)	30" x 40" (762 x 1016)	60" x 40" (1524 x 1016) or 30" x 80" (762 x 2032)

*Individual sections not to exceed 30" x 48" (762 x 1219).

Type B and C dampers have the same overall damper size but the connecting ducts are smaller due to the B or C enclosures. See Type B and Type C specification drawings for maximum duct sizes.

In cases when the openings are larger than specified in note 7, a UL tested and qualified steel mullion must be provided between assemblies (Refer to supplementary installation document FDSMINST). Mullion is for use in 1 1/2 hour static applications only.

8. Actuators and accessories: Nailor multi-blade fire dampers are supplied with an internal locking quadrant as standard to hold damper blades in the open position. If MLS-300 position indicators are used, refer to the proper installation instructions for the MLS-300.

9. Multiple Section assemblies: In multiple assemblies of vertical or horizontal dampers, the frames shall be joined together on both sides of the damper using 1/4" (6) long welds, 1/4" (6.35) dia. bolts and nuts, or #8 sheet metal screws. Maximum 6" (152) on center.

Model Series 1200 multi-section horizontal dampers over two sections wide require a 10 ga. (3.51) Z shaped mullion (shown below). One mullion required for dampers up to 144"(3658) wide. Horizontal damper assemblies, two sections high (deep), require a 10 ga. (3.51) flat mullion between sections (shown below). Mullions and damper frames shall be bolted together with 1/4" (6.35) dia. nuts and bolts on a maximum of 6" (152) on center.

Z MULLION:

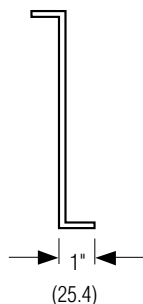
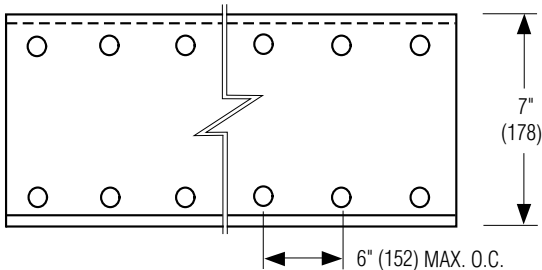

FLAT MULLION:

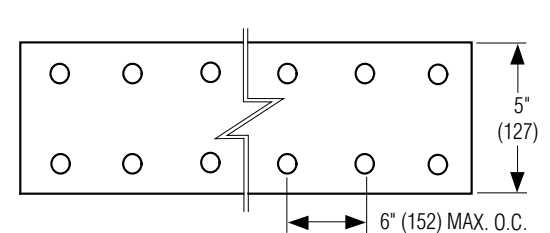

IMPORTANT:

- DO NOT CAST DAMPER IN PLACE.
- DO NOT FASTEN RETAINING ANGLES OR DAMPER DIRECTLY TO WALL OR FLOOR.
- DO NOT INSTALL DAMPER OUT OF SQUARE OR OUT OF FLAT.
- VERTICAL MOUNTING SHOWN ON MASONRY WALL.
- FOR INSTALLATION IN DRYWALL FRAMING, SEE DOC. FDSWSFINST.
- HORIZONTAL MOUNTING SIMILAR FOR MASONRY WALL.

Dimensions are in inches (mm).

REFER TO THE APPROPRIATE NAILOR INSTALLATION INSTRUCTION SUPPLEMENTS FOR THE FOLLOWING SPECIAL REQUIREMENTS:

- STEEL MULLIONS (for dampers in oversized wall openings) FDSMINST
- SINGLE SIDED RETAINING ANGLES FDSRAINST
- STEEL AND WOOD STUD FRAMING FDSWSFINST
- CAVITY SHAFT WALL PARTITIONS FDCSWINST
- DUCTMATE BREAKAWAY CONNECTIONS FDDMINST
- TDC/TDF FLANGED DUCT CONNECTION FDTDCFINST
- QUICK-SET RETAINING ANGLES FDQSRA



Houston, Texas
Tel: 281-590-1172
Fax: 281-590-3086

Las Vegas, Nevada
Tel: 702-648-5400
Fax: 702-638-0400

Toronto, Canada
Tel: 416-744-3300
Fax: 416-744-3360

Calgary, Canada
Tel: 403-279-8619
Fax: 403-279-5035

**"QUICK-SET" RETAINING ANGLES BOTH SIMPLIFY AND SPEED INSTALLATION,
 SAVING BOTH TIME AND MONEY.**

BENEFITS:

- One piece angles are fastened together in the corners. Only two sets of angles to handle per damper (rather than four separate angles per side).
- Angles are shipped with damper - no sorting or matching.
- Provided with pre-drilled fastening holes on 2" (51) centers to ensure correct angle/sleeve attachment.
- Factory fabricated by Nailor to suit the individual fire damper.
- Reduced cost when compared to conventional retaining angles.
- Dampers can ship directly to the job site complete with all necessary installation sheet metal hardware (saves on double handling at contractor's shop).
- Help ensure a correct installation as per U.L. approved installation instructions.

The majority of installing contractors view fire damper installation as a costly time consuming and troublesome procedure. Eight conventional angles must be custom fabricated for each damper either in a sheet metal shop or at the job site and sized to suit each individual damper. Invariably, they are mislaid or lost and must be matched to each factory supplied damper.

The Nailor "Quick-Set" solution solves the majority of problems. They are pre-formed to fit and ship with the individual damper for ultimate convenience. "Quick-Set" angles are supplied with correctly spaced pre-drilled screw-holes to ensure a quick, easy and accurate installation for all integral sleeve Nailor fire and combination fire/smoke dampers - no measuring required.

"Quick-Set" retaining angles provide the "complete" installation package. Simple, fast, convenient.

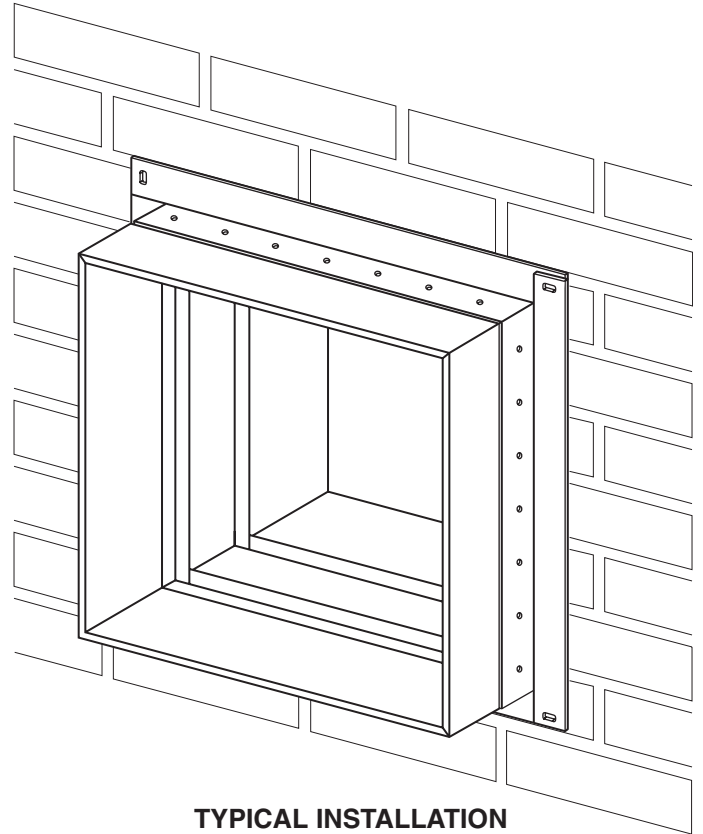

TYPICAL INSTALLATION

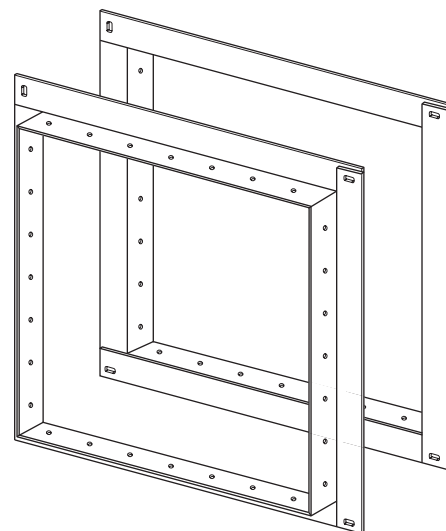

**TYPICAL PAIR OF PRE-ASSEMBLED
 'QUICK-SET' RETAINING ANGLES**



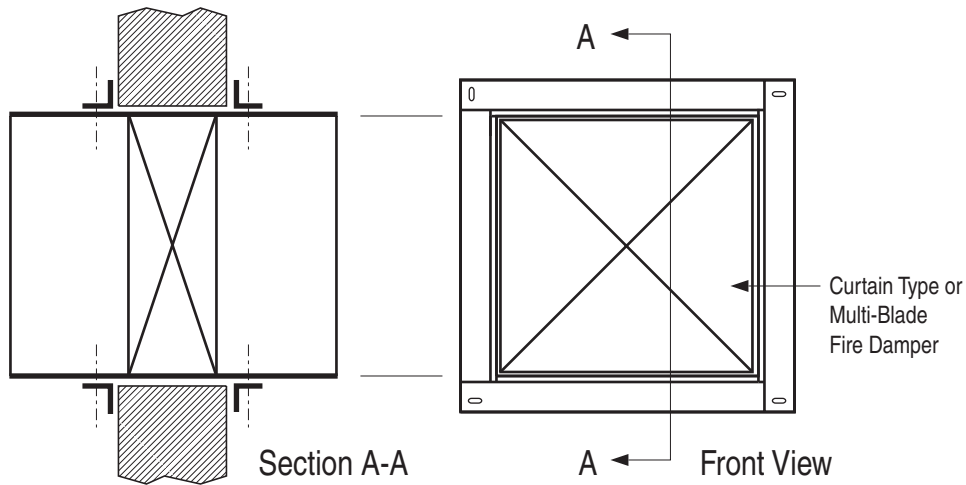

FIGURE 1. TYPICAL TWO SIDED INSTALLATION.

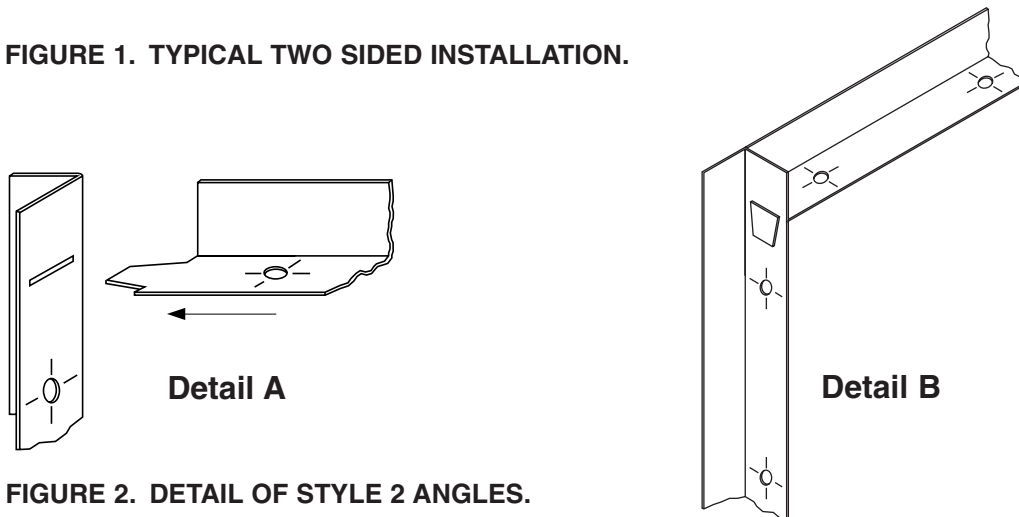

FIGURE 2. DETAIL OF STYLE 2 ANGLES.

APPLICATION:

The Nailor Quick-Set Retaining Angle System may be used in lieu of conventional retaining angles on all Nailor Fire and Combination Fire / Smoke Dampers.

Quick-Set angles are supplied in one of two styles, dependent upon fire resistance label, damper size and installation method.

Style 1: 1 1/2" x 1 1/2" x 20 ga. (38 x 38 x 1.0) Four sides are connected together with rivets in three corners.

Standard for the majority of applications with the following limitations:

- 1 1/2 hour label fire dampers
- Maximum Size: 36" x 36" (914 x 914)
- Two sided installation only

Style 2: 1 1/2" x 1 1/2" x 16 ga. (38 x 38 x 1.6) Slot and tab design. The retaining angle assembly for each side has four angles, each with a tab end and a slot end (Detail A). The tabs are to be inserted into the slots and knocked down either before or after fastening to the sleeve (Detail B).

- 1 1/2 or 3 hour label fire dampers
- Maximum Size: 90" x 48" (2286 x 1219) or 48" x 90" (1219 x 2286)
- Single side (1 1/2 hour only. Refer to Single Side Retaining Angles Supplementary Installation Instructions for size limitations) or two sided installation

Refer to the Following Installation Instructions:

Curtain Type Fire Dampers (D)0100 & (D)0500	FDINST
Curtain Type Fire Dampers 0200 & 0500 Thinline	FDTINST
Multi-Blade Fire Dampers 1200 & 1250	MBFDINST
Combination Fire/Smoke Dampers 1220	1220INST
Combination Fire/Smoke Dampers 1270	1270INST
Single Side Retaining Angles	FDSSRAINST



Dimensions are in inches (mm).



Houston, Texas
Tel: 281-590-1172
Fax: 281-590-3086

Las Vegas, Nevada
Tel: 702-648-5400
Fax: 702-638-0400

Toronto, Canada
Tel: 416-744-3300
Fax: 416-744-3360

Calgary, Canada
Tel: 403-279-8619
Fax: 403-279-5035

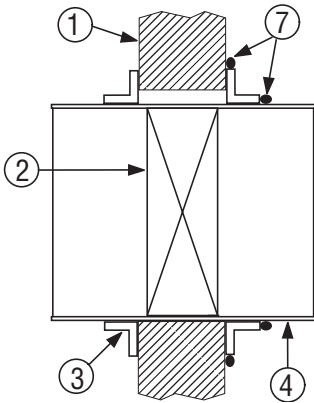

Figure 1. Damper ducted both sides.

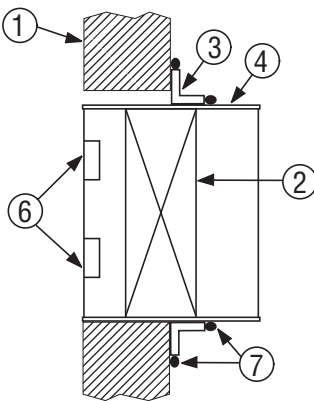

Figure 2. Damper sleeve with tabs for grille mounting

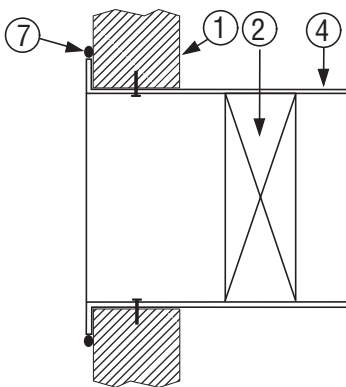

Figure 3. Out of Wall damper with flanged sleeve for grille mounting

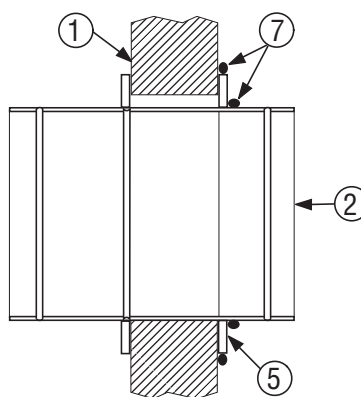

Figure 4. Round damper

APPLICATION:

Application of sealant between the retaining angles, retaining plates, or sleeve retaining flange and the fire rated wall or floor as applicable to the damper installation is not required by UL as a standard procedure. However, if an airtight seal is required by specification or local building code, sealant shall be applied as shown.

METHOD

Follow the sealant manufacturers' directions; remove dirt, grease, and moisture from the surfaces to be sealed. Apply a continuous bead of Dow Corning RTV732, Hilti Corporation FS-One, Nuco Inc. Self-Seal GG-200, Johns Manville Firetemp C1 or GE RTV108 sealant. Location of sealant should be as shown in Figures 1 through 4 and may be applied on one or both sides of the fire separation, as applicable to the model specific installation.

IMPORTANT:

Do not apply sealant within the required expansion gap between the damper and the fire rated wall or floor.

Press the surface of the sealant in place to dispel any air. Allow sealant to set and become tack-free before operating the damper.

Refer to the appropriate damper installation instructions for details on damper installation.

ITEMS

1. Fire Rated Wall or Floor
2. Damper
3. Retaining Angles
4. Sleeve
5. Retaining Plate
6. Mounting Tabs
7. Sealant (refer to text for specific sealant)

Dimensions are in inches (mm).



Houston, Texas
Tel: 281-590-1172
Fax: 281-590-3086

Las Vegas, Nevada
Tel: 702-648-5400
Fax: 702-638-0400

Toronto, Canada
Tel: 416-744-3300
Fax: 416-744-3360

Calgary, Canada
Tel: 403-279-8619
Fax: 403-279-5035

APPLICATION:

Fire dampers are UL/ULC Classified for their maximum size or maximum assembly size. Generic steel mullions can be used in static HVAC systems to separate vertically mounted 1 1/2 hour labeled galvanized steel fire dampers in vertical wall openings larger than maximum UL/ULC permitted multiple damper assembly size. Fire dampers must not exceed a maximum 120" (3048) height by unlimited width using vertical mullions every 120" (3048) max. Mullions are not intended to be part of the ductwork. (i.e. exposed to airflow).

Whenever the duct size exceeds the maximum damper width or height, the opening must be divided into two or more separate openings with a mullion installed between the damper sections. The mullion consists of a vertical and/or horizontal mullion and mullion caps. One cap for each end of the mullion.

The steel mullion is intended for use only in concrete block or poured walls with 7" (178) minimum and 12" (305) maximum thickness. Hollow concrete block walls are to be suitably filled with minimum 3500 psi concrete for proper securing of mullions.

Important Note: Steel mullions are for use in static systems only. UL/ULC does not acknowledge their use with dynamic fire dampers.

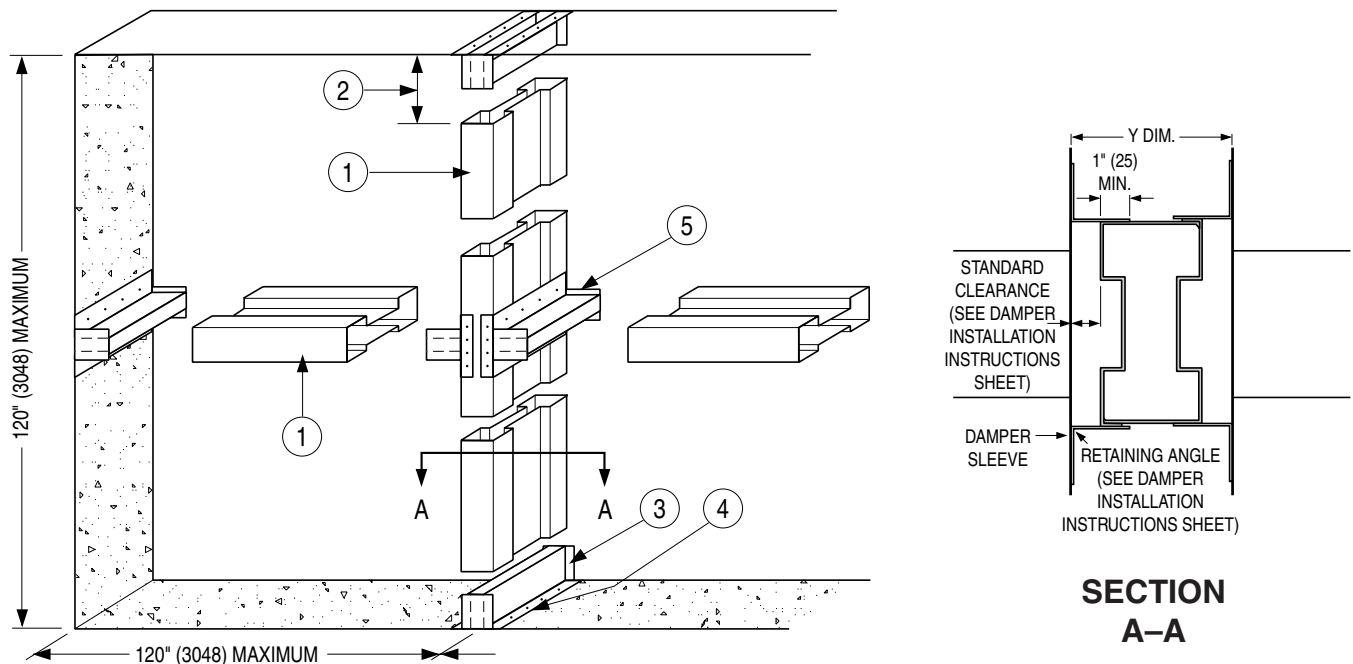

FABRICATION AND GENERAL INSTALLATION:

1. Fabricate mullions of 16 ga. (1.6) galvanized steel as shown in **Figure 1**. Two mullion pieces are joined with 3/16" (5) diameter steel pop rivets or 3/4" (19) long welds located 6" (152) maximum from each end and 12" (305) O.C. maximum.
2. The mullion should permit clearance between the mullion and top cap. Required clearance is 1/8" (3) per foot of wall opening height. Minimum permitted clearance is 1/4" (6). Maximum permitted clearance is 1 1/4" (32) (e.g. for an 8 ft. (2438) high opening the permitted clearance is 1/8" (3) x 8 = 1" (25) +).
3. Fabricate two caps for each mullion of 12 ga. (2.8) galvanized steel as shown in **Figure 2** for vertical and horizontal mullions. (Caps must permit mullion to overlap each cap by minimum 3" (76)). Cap height is calculated by adding 3" (76) to permitted mullion expansion clearance which is 1/8" (3) per foot of wall opening height. Insert mullion caps into mullion ends allowing mullion to float between the caps. Do not fasten mullion to caps in any way. Locate within opening to provide correct expansion clearance for dampers.
4. Drill holes in caps and concrete for anchoring steel mullion caps with 1/4" (6) – 20 x 5/16" (8) steel screws and 3/8" (10) diameter x 1" (25) concrete expansion anchors. The eight holes to secure the cap (**Figure 3**) are equally spaced, X ÷ 8 from both ends and 1/2" (13) inwards of each side.
5. Set horizontal mullion caps at vertical mullions as shown (**Figure 4**). If steel lintels are present, four 1" (25) welds (two per mullion cap leg) may be used to anchor each mullion cap.

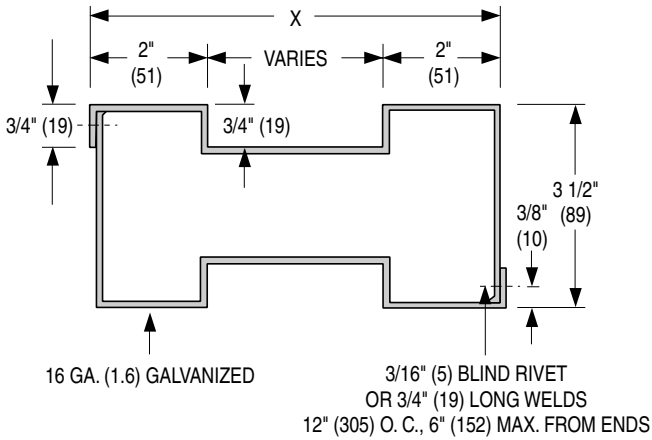

FIGURE 1
MULLION CROSS-SECTION

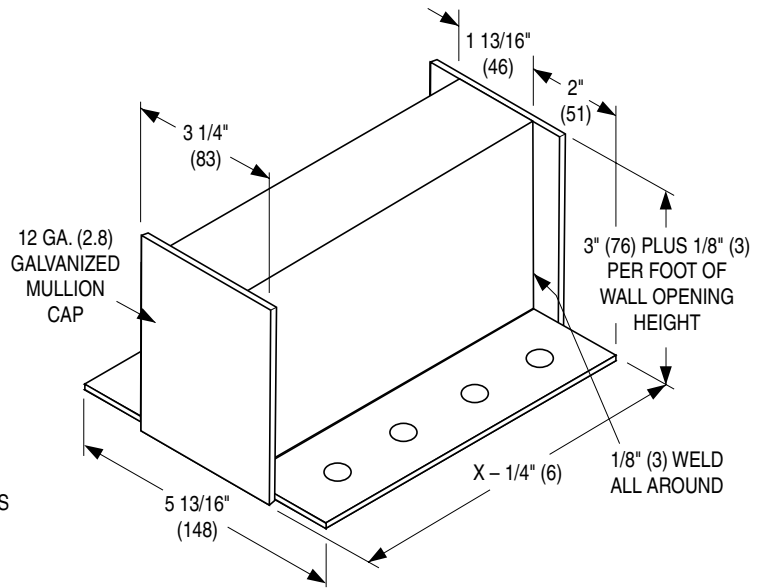

FIGURE 2

X = WALL THICKNESS

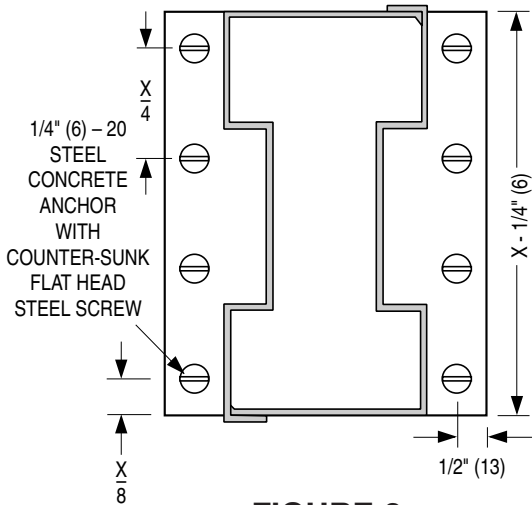

FIGURE 3

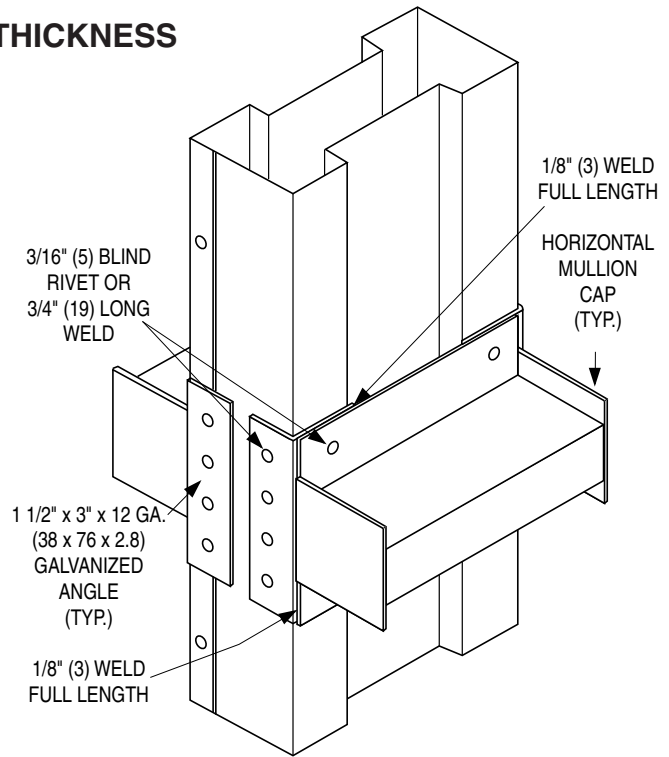

FIGURE 4



Refer to the UL or ULC Classification Marking on the Product

These instructions comply with Underwriters Laboratories Safety Standard 555.

Dimensions are in inches (mm).

Page 2 of 2



Houston, Texas
Tel: 281-590-1172
Fax: 281-590-3086

Las Vegas, Nevada
Tel: 702-648-5400
Fax: 702-638-0400

Toronto, Canada
Tel: 416-744-3300
Fax: 416-744-3360

Calgary, Canada
Tel: 403-279-8619
Fax: 403-279-5035

These instructions are for installing vertical mount fire and combination fire smoke dampers in a fire resistant ventilation duct (UL Ventilation duct Assembly HNLN.V-5).



NOTES:

1. The damper sleeve must slip inside the fire resistant duct spool. Damper sleeve assembly will be 1/4" (6), 1/2" (13) maximum, smaller than duct spool size.
2. Damper is to be supplied with factory mounted sleeve. Sleeve gauge will be minimum of 16 ga. (1.5) for dampers up to 36" wide x 24" high (914 x 610) and 14 ga. (2) for dampers exceeding 36" wide x 24" high (914 x 610).
3. Mounting angles need to be the following sizes:
 - 1 1/2" x 1 1/2" x 1/4" up to 24" (38 x 38 x 6 up to 610)
 - 2" x 2" x 1/4" over 24" up to 32" (51 x 51 x 6 over 610 up to 813)
 - 2 1/2" x 2 1/2" x 1/4" over 32" up to 40" (64 x 64 x 6 over 813 up to 1016)
 - 3" x 3" x 1/4" above 40" (76 x 76 x 6 above 1016)
4. Mounting angle fasteners:
 - #10 bolts or screws
 - 3/16" (4.7) steel rivets
 - 1/2" (13) long welds
5. Mounting Angle Fasteners Spacing:
 - Mounting angles to dampers, space fasteners on 6" (152) on center.
 - Mounting angle to spool flange, space fasteners on 12" (305) on center.
 - Minimum 2 fasteners per side
6. Hanger rods:
 - 3/8" (10) threaded rod anchored to the floor above and attached to the mounting angles through hole in the angles and secured with hex nut and washer (items 5 & 6). Anchor to masonry per assembly No. V-5.
7. Duct to Damper Sleeve Connection:
 - See the fire damper or the combination fire smoke installation instructions for breakaway, flanged, or non-breakaway connections.

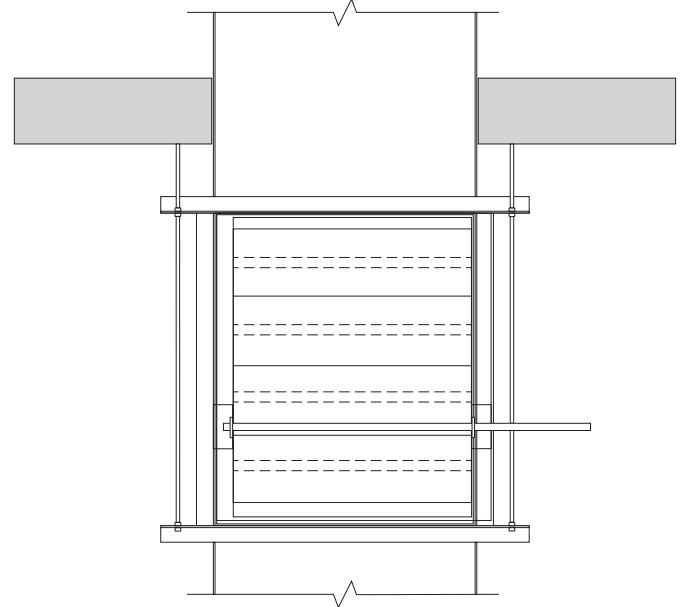

END VIEW

Item	Description
1	Fire Resistant Ventilation Duct (UL HNLN Assembly No. V-5)
2	Fire Damper or Combination Fire/Smoke Damper
3	Hanger rods in accordance with assembly No. V-5
4	Mounting angles (see instruction #3)
5	3/8" (10) hex nuts
6	3/8" (10) flat washer
7	Mounting angle fasteners (see instruction #4)

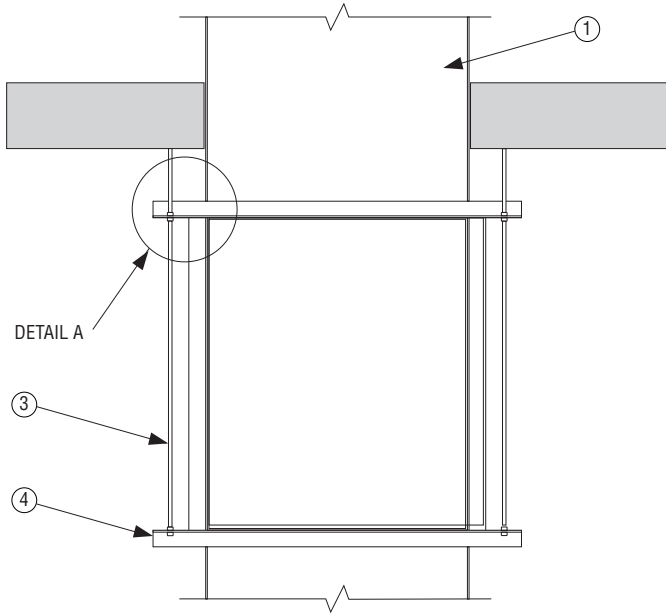

END VIEW

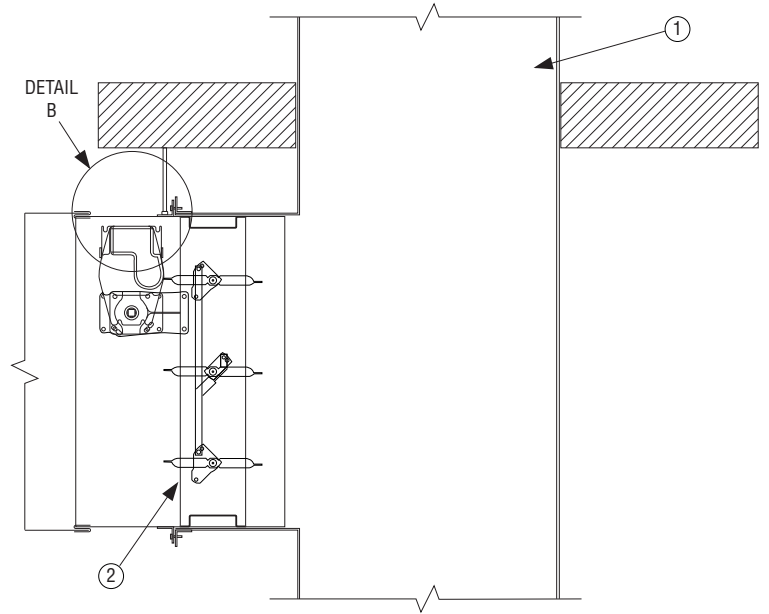

SIDE VIEW

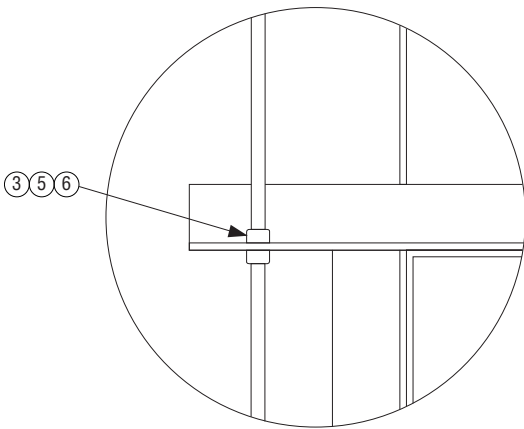

DETAIL A

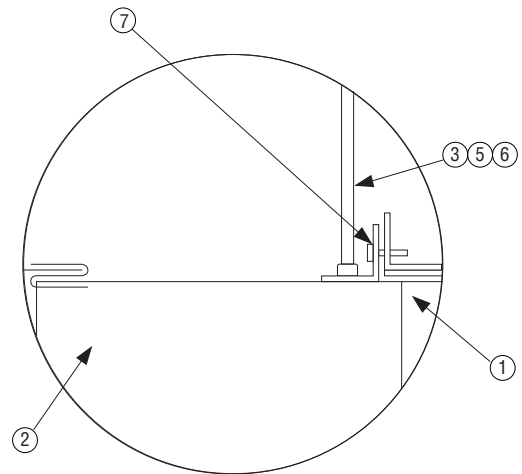

DETAIL B

Dimensions are in inches (mm).



Houston, Texas
Tel: 281-590-1172
Fax: 281-590-3086

Las Vegas, Nevada
Tel: 702-648-5400
Fax: 702-638-0400

Toronto, Canada
Tel: 416-744-3300
Fax: 416-744-3360

Calgary, Canada
Tel: 403-279-8619
Fax: 403-279-5035

APPLICATION:

- The MLS-300 Position Indicator Package operates as a function of the damper blade position and provides the ability to remotely indicate damper blade position.
- The MLS-300 incorporates two SPDT switches and provides a positive open or closed signal when used in conjunction with remote indicator lights. MLS-300's are used in active smoke control management systems to positively indicate the status of all combination fire/smoke and smoke dampers in the building.
- The MLS-300 is available only as a factory installed option on combination fire / smoke and smoke dampers.

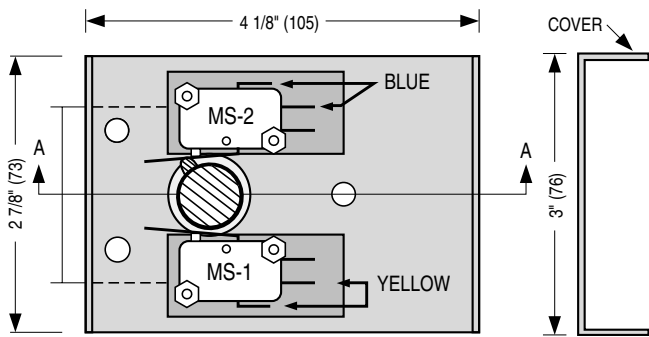

EXTERNAL RIGHT HAND MOUNTING: FRONT VIEW (LESS COVER)

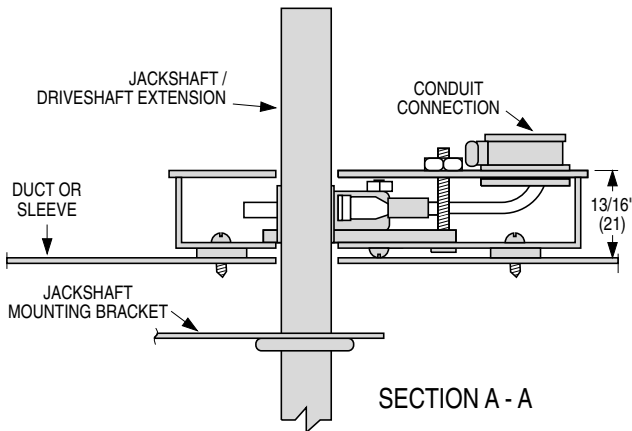

SECTION A - A

Position Indicator Microswitch Data:

Switch Type: Single Pole double throw (2)
 15 Amps, 1/3 HP, 125, 250 Vac or 24 Vdc.
 1/2 Amp, 125 Vdc. 1/4 Amp, 250 Vdc.

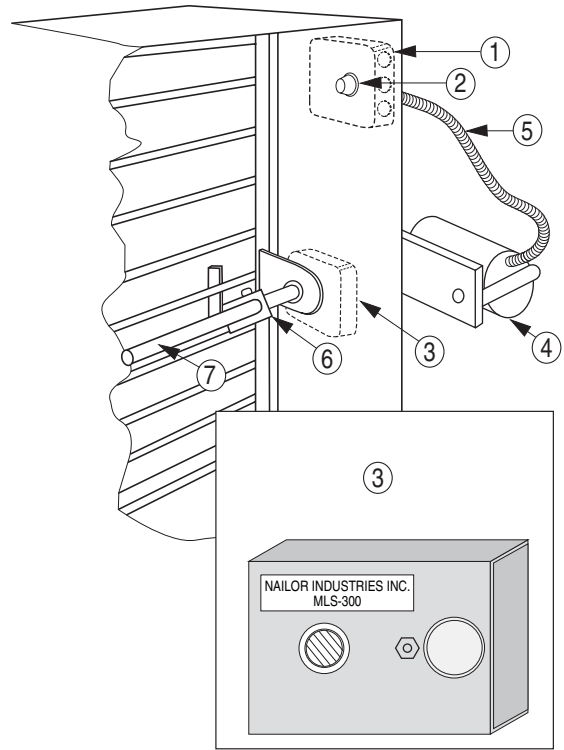

Typical Combination Fire / Smoke Damper Installation With UL Listed Actuator Description:

1. Electrical Junction Box. [and EP switch with pneumatic actuator(s)]
2. ERL 165, 212, 250, 350 Electric Resettable Link (Heat Sensor)
3. MLS-300 Position indicator package
4. Actuator (pneumatic illustrated).
5. Silicone Tubing or Flexible Conduit
6. Over-Center Knee Lock
7. Jackshaft

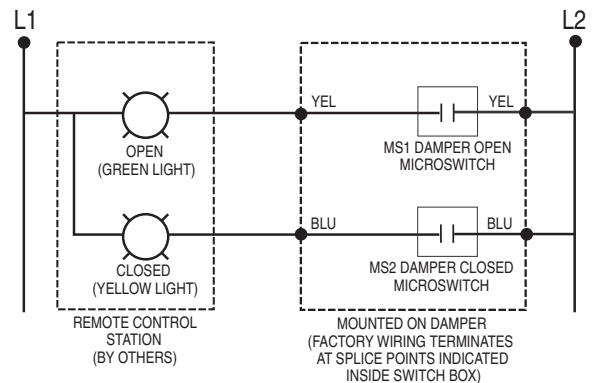

Figure 1. MLS-300 Wiring Schematic.

Dimensions are in inches (mm).

Electrical Connections:

1. Remove cover of junction box. There are four or six coded color wires. Four wires are the MLS-300 position indicator package. If six wires are present, the additional two are the field connection for either an electric actuator or an EP switch for a pneumatic actuator.

MS1 is damper open signal.

MS2 is damper closed signal.

Important: Installer must double check continuity of **MS1** and **MS2** before wiring to confirm which switch signals the damper's open or closed position.

2. Connect external wiring and electrical power supply (120 or 24 Vac) in accordance with N.E.C. and any applicable local codes.
3. Replace junction box cover and check operation.

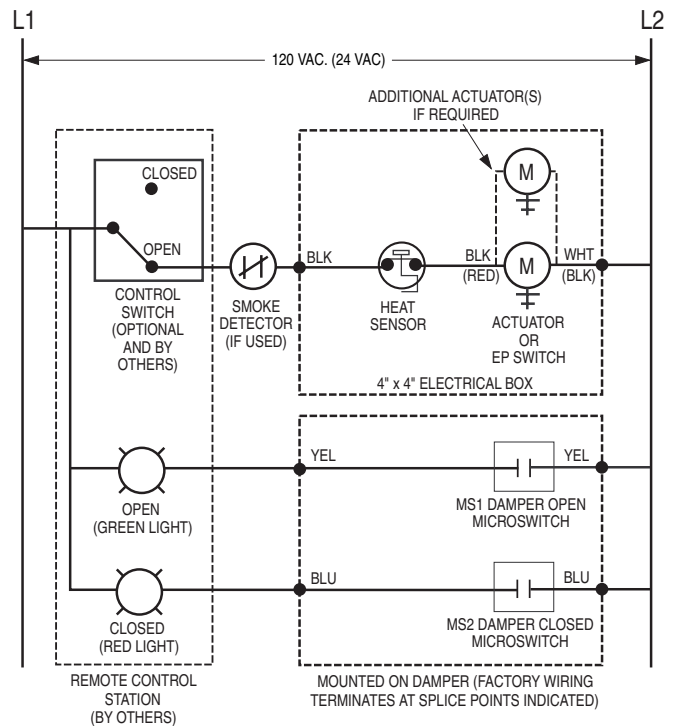

Figure 2. Combination Fire/Smoke Damper Wiring Schematic.

Dimensions are in inches (mm).

Page 2 of 2



Houston, Texas
Tel: 281-590-1172
Fax: 281-590-3086

Las Vegas, Nevada
Tel: 702-648-5400
Fax: 702-638-0400

Toronto, Canada
Tel: 416-744-3300
Fax: 416-744-3360

Calgary, Canada
Tel: 403-279-8619
Fax: 403-279-5035