



DYNAMIC STAINLESS STEEL MULTI-BLADE FIRE DAMPER
 FOR USE IN DYNAMIC OR STATIC SYSTEMS
 HIGH PERFORMANCE • AIRFOIL BLADE
 1 1/2 HR. LABEL • VERTICAL MOUNT
MODELS: D1200SS AND D1201SS (TYPE A)



QUALIFICATIONS:

- **UL 555 & CANULC-S112 CLASSIFIED DYNAMIC FIRE DAMPER 1 1/2 hr. Label (File # R9492).**
- **Meets NFPA 80, 90A and 101 as well as IBC and NBC (Canada) Building Code requirements.**
- **California State Fire Marshal Listing No. 03225-0935:0101.**
- **City of New York. MEA# 366-03-M.**
- **Maximum velocity 2000 fpm @ 4" w.g. (10 m/s @ 1 kPa).**

The D1200SS Series dampers are ideal for high humidity or mildly corrosive applications where building codes require a fire damper for the protection of ductwork penetrations in walls that have a fire resistance rating of up to 2 hours.

The D1200SS Series is classified for use in dynamic "fans on" systems where the HVAC system remains operative in the event of a fire alarm. Damper closure under airflow is assured.

The D1200SS Series has been especially designed and tested to provide premium performance. Airfoil blade design and elimination of blade sills, top and bottom, provide a low pressure drop design.

The D1200SS Series features the industry proven over-center knee-lock design with high torque spring/fusible link closure.

Unique, inter-locking double skin blade design provides flame and smoke seal under fire conditions.

The D1200SS is supplied as standard with an internal crank arm and locking screw which holds the damper in the fully open position, but may also be used for system balancing if required.

The D1200SS is available in either Type 304 or 316 stainless steel.

STANDARD SPECIFICATION:

- Frame:** 5" x 7/8" x 16 ga. (127 x 22 x 1.6) stainless steel hat channel.
- Blades:** 14 ga. (2.0) equivalent stainless steel formed airfoil on 5 1/2" (140) centers. Opposed blade action.
- Linkage:** Concealed in frame. 12 ga. (2.7) stainless steel.
- Bearings:** 1/2" (13) dia. sintered stainless steel.
- Axles:** 1/2" (13) dia. stainless steel double bolted to blades.
- Jackshaft:** 1/2" (13) dia. stainless steel. CCW rotation to open. Internal locking quadrant is factory installed.
- Fusible Link:** 165°F (74°C) standard.
- Minimum Size:** Vertical mount only: 8" x 8" (203 x 203).
- Maximum Size:** Single Section
Vertical mount only: 36" x 48" (914 x 1219).
Multiple Section Assembly
Vertical mount only: 72" x 96" (1829 x 2438) or
144" x 48" (3658 x 1219).

Dampers with duct heights less than 8" require a Type 'B' sleeve enclosure (Model D1202SS). Units less than 8" (203) in width only, or in both width and height, require a Type 'C' enclosure (Model D1203SS).

BASE MODEL SELECTION:

- D1200SS** Less sleeve.
- D1201SS** Standard factory sleeve 16" long x 20 ga. (406 x 1.0) (18 ga. [1.3] for dampers over 84" [2134] in width).
- D1201SS** Non-standard sleeve. Specify _____ length _____ ga. Available up to 36" (914) dependent upon wall thickness and 10 through 20 ga. (3.5 through 1.0).

CONSTRUCTION TYPE:

- 304** Type 304 Stainless Steel construction (Standard)
- 316** Type 316 Stainless Steel construction (Optional)

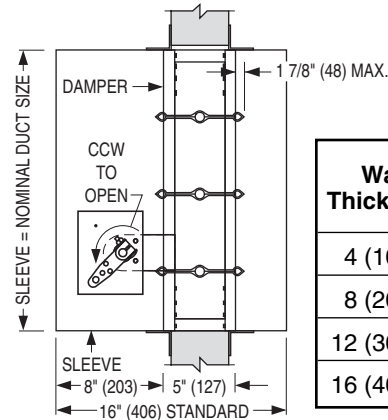
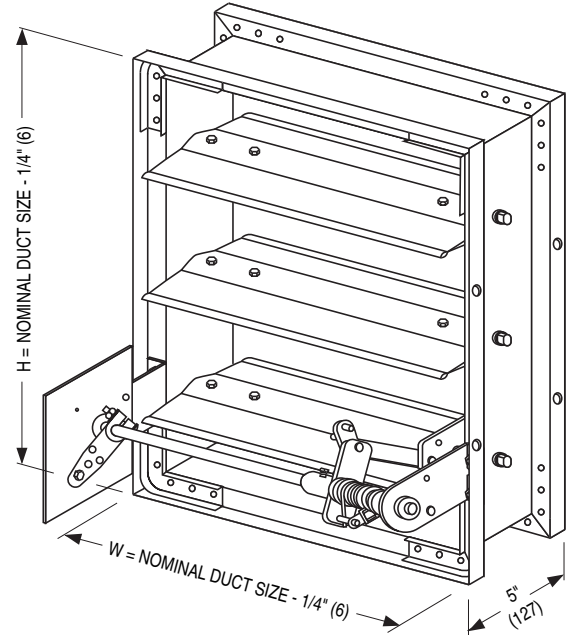

Wall Thickness	Minimum Sleeve Length
4 (102)	16 (406)
8 (203)	20 (508)
12 (305)	24 (610)
16 (406)	28 (711)

OPTIONS:

- SMP** Side mounting plate
 - MLS-300** Position indicator switch pack
 - JSS** Flexible stainless steel jamb seals
 - QS1** Quick-set retaining angle (one side)
 - QS2** Quick-set retaining angles (two sides)
- Note:** QS1 and QS2 are galvanized steel.
- Special features** _____

For installation instructions, see IOM-MBSSFDINST.

Dimensions are in inches (mm).

SCHEDULE TYPE:				
PROJECT:				
ENGINEER:	DATE	B SERIES	SUPERSEDES	DRAWING NO.
CONTRACTOR:	4 - 3 - 13	1200	1 - 1 - 12	D1200SS-1



DYNAMIC STAINLESS STEEL MULTI-BLADE FIRE DAMPER
 FOR USE IN DYNAMIC OR STATIC SYSTEMS
 HIGH PERFORMANCE • AIRFOIL BLADE
 1 1/2 HR. LABEL • VERTICAL MOUNT
MODEL: D1202SS (TYPE B SLEEVE ENCLOSURE)



FOR DUCTS UNDER 8" (203) IN HEIGHT AND 8" (203) OR MORE IN WIDTH
QUALIFICATIONS:

- **UL 555 & CAN/ULC-S112 CLASSIFIED DYNAMIC FIRE DAMPER**
1 1/2 hr. Label (File # R9492).
- **Meets NFPA 80, 90A and 101 as well as IBC and NBC (Canada) Building Code requirements.**
- **California State Fire Marshal Listing No. 03225-0935:0101.**
- **City of New York. MEA# 366-03-M.**
- **Maximum velocity 2000 fpm @ 4" w.g. (10 m/s @ 1 kPa).**

The D1200SS Series dampers are ideal for high humidity or mildly corrosive applications where building codes require a fire damper for the protection of ductwork penetrations in walls that have a fire resistance rating of up to 2 hrs.

The D1200SS Series is classified for use in dynamic "fans on" systems where the HVAC system remains operative in the event of a fire alarm. Damper closure under airflow is assured.

The D1200SS Series has been especially designed and tested to provide premium performance. Airfoil blade design and elimination of blade sills, top and bottom, provide a low pressure drop design.

The D1200SS Series features the industry proven over-center knee-lock design with high torque spring/fusible link closure.

Unique, inter-locking double skin blade design provides flame and smoke seal under fire conditions.

The D1202SS is supplied as standard with an internal crank arm and locking screw which holds the damper in the fully open position, but may also be used for system balancing if required.

The D1202SS is available in either Type 304 or 316 stainless steel.

STANDARD SPECIFICATION:

- Frame:** 5" x 7/8" x 16 ga. (127 x 22 x 1.6) stainless steel hat channel.
- Blades:** 14 ga. (2.0) equivalent stainless steel formed airfoil on 5 1/2" (140) centers. Opposed blade action.
- Linkage:** Concealed in frame. 12 ga. (2.7) stainless steel.
- Bearings:** 1/2" (13) dia. sintered stainless steel.
- Axles:** 1/2" (13) dia. stainless steel double bolted to blades.
- Jackshaft:** 1/2" (13) dia. stainless steel. CCW rotation to open. Internal locking quadrant is factory installed.
- Fusible Link:** 165°F (74°C) standard.
- Min. Duct Size:** Vertical mount only: 8" x 4" (203 x 102). (Overall damper height is 8" [203]).
- Max. Duct Size:** Single Section
Vertical mount only: 36" x 7 1/2" (914 x 191).
Multiple Section Assembly
Vertical mount only: 144" x 7 1/2" (3658 x 191).

Units less than 8" (203) in width only, or in both width and height, require a Type 'C' enclosure (Model D1203SS).

BASE MODEL SELECTION:

- D1202SS** Standard factory sleeve 16" long x 20 ga. (406 x 1.0) (18 ga. [1.3] for dampers over 84" [2134] in width).
- D1202SS** Non-standard sleeve. Specify _____ length _____ ga. Available up to 36" (914) dependent upon wall thickness and 10 through 20 ga. (3.5 through 1.0).

CONSTRUCTION TYPE:

- 304** Type 304 Stainless Steel construction (Standard)
- 316** Type 316 Stainless Steel construction (Optional)

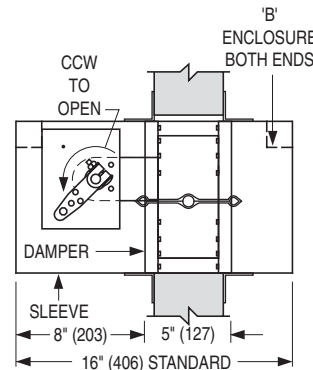
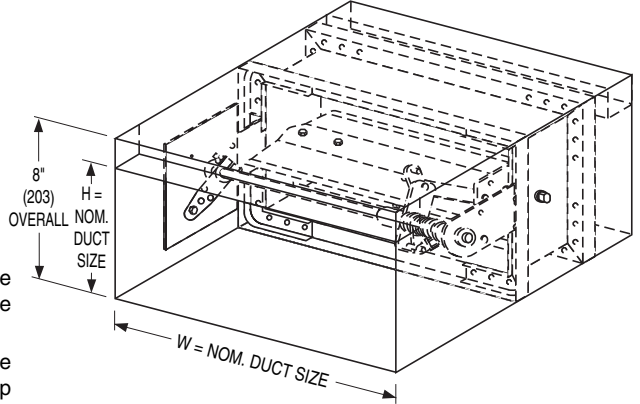

Wall Thickness	Minimum Sleeve Length
4 (102)	16 (406)
8 (203)	20 (508)
12 (305)	24 (610)
16 (406)	28 (711)

OPTIONS:

- MLS-300** Position indicator switch pack
 - JSS** Flexible stainless steel jamb seals
 - QS1** Quick-set retaining angle (one side)
 - QS2** Quick-set retaining angles (two sides)
- Note:** QS1 and QS2 are galvanized steel.
- Special features** _____

For installation instructions, see IOM-MBSSFDINST.

Dimensions are in inches (mm).

SCHEDULE TYPE:				
PROJECT:				
ENGINEER:	DATE	B SERIES	SUPERSEDES	DRAWING NO.
CONTRACTOR:	4 - 3 - 13	1200	1 - 1 - 12	D1200SS-2



DYNAMIC STAINLESS STEEL MULTI-BLADE FIRE DAMPER
 FOR USE IN DYNAMIC OR STATIC SYSTEMS
 HIGH PERFORMANCE • AIRFOIL BLADE
 1 1/2 HR. LABEL • VERTICAL MOUNT
 ROUND DUCT CONNECTION
MODEL: D1203SS (TYPE C SLEEVE ENCLOSURE)



QUALIFICATIONS:

- **UL 555 & CAN/ULC-S112 CLASSIFIED DYNAMIC FIRE DAMPER**
1 1/2 hr. Label (File # R9492).
- **Meets NFPA 80, 90A and 101 as well as IBC and NBC (Canada) Building Code requirements.**
- **California State Fire Marshal Listing No. 03225-0935:0101.**
- **City of New York. MEA# 366-03-M.**
- **Maximum velocity 2000 fpm @ 4" w.g. (10 m/s @ 1 kPa).**

The D1200SS Series dampers are ideal for high humidity or mildly corrosive applications where building codes require a fire damper for the protection of ductwork penetrations in walls that have a fire resistance rating of up to 2 hours.

The D1200SS Series is classified for use in dynamic "fans on" systems where the HVAC system remains operative in the event of a fire alarm. Damper closure under airflow is assured.

The D1200SS Series has been especially designed and tested to provide premium performance. Airfoil blade design and elimination of blade sills, top and bottom, provide a low pressure drop design.

The D1200SS Series features the industry proven over-center knee-lock design with high torque spring/fusible link closure.

Unique, inter-locking double skin blade design provides flame and smoke seal under fire conditions.

The D1203SS is supplied as standard with an internal crank arm and locking screw which holds the damper in the fully open position, but may also be used for system balancing if required.

The D1203SS is available in either Type 304 or 316 stainless steel.

STANDARD SPECIFICATION:

- Frame:** 5" x 7/8" x 16 ga. (127 x 22 x 1.6) stainless steel hat channel.
- Blades:** 14 ga. (2.0) equivalent stainless steel formed airfoil on 5 1/2" (140) centers. Opposed blade action.
- Linkage:** Concealed in frame. 12 ga. (2.7) stainless steel.
- Bearings:** 1/2" (13) dia. sintered stainless steel.
- Axles:** 1/2" (13) dia. stainless steel double bolted to blades.
- Jackshaft:** 1/2" (13) dia. stainless steel. CCW rotation to open. Internal locking quadrant is factory installed.
- Fusible Link:** 165°F (74°C) standard.
- Min. Duct Size:** Vertical mount only: 4" (102) diameter. (Overall damper size is 8" x 8" [203 x 203] min.).
- Max. Duct Size:** Single Section
Vertical mount only: 34" (864) diameter.
Multiple Section Assembly
Vertical mount only: 70" (1778) diameter.

BASE MODEL SELECTION:

- D1203SS** Standard factory sleeve 16" long x 20 ga. (406 x 1.0) (18 ga. [1.3] for dampers over 84" [2134] in width).
- D1203SS** Non-standard sleeve. Specify _____ length _____ ga. Available up to 36" (914) dependent upon wall thickness and 10 through 20 ga. (3.5 through 1.0).

CONSTRUCTION TYPE:

- 304** Type 304 Stainless Steel construction (Standard)
- 316** Type 316 Stainless Steel construction (Optional)

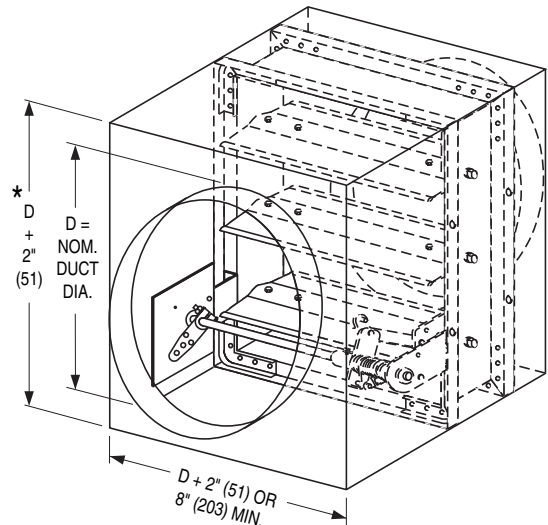

* or 8" (203) min.

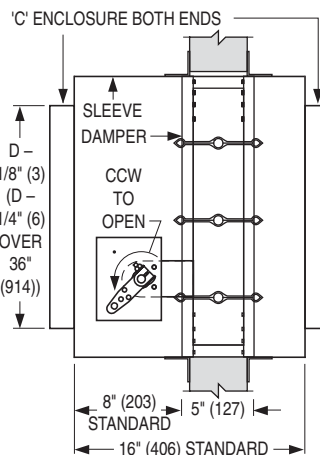

Wall Thickness	Minimum Sleeve Length
4 (102)	16 (406)
8 (203)	20 (508)
12 (305)	24 (610)
16 (406)	28 (711)

OPTIONS:

- MLS-300** Position indicator switch pack
- JSS** Flexible stainless steel jamb seals
- QS1** Quick-set retaining angle (one side)
- QS2** Quick-set retaining angles (two sides)
- Note:** QS1 and QS2 are galvanized steel.
- Special features** _____

For installation instructions, see IOM-MBSSFDINST.

Dimensions are in inches (mm).

SCHEDULE TYPE:				
PROJECT:				
ENGINEER:	DATE	B SERIES	SUPERSEDES	DRAWING NO.
CONTRACTOR:	4 - 3 - 13	1200	1 - 1 - 12	D1200SS-3



DYNAMIC STAINLESS STEEL MULTI-BLADE FIRE DAMPER
 FOR USE IN DYNAMIC OR STATIC SYSTEMS
 HIGH PERFORMANCE • AIRFOIL BLADE
 3 HR. LABEL • VERTICAL MOUNT
MODELS: D1200SS-3 AND D1201SS-3 (TYPE A)



QUALIFICATIONS:

- **UL 555 & CAN/ULC-S112 CLASSIFIED DYNAMIC FIRE DAMPER 3 hr. Label (File # R9492).**
- **Meets NFPA 80, 90A and 101 as well as IBC and NBC (Canada) Building Code requirements.**
- **California State Fire Marshal Listing No. 03225-0935:0101.**
- **City of New York. MEA# 366-03-M.**
- **Maximum velocity 2000 fpm @ 4" w.g. (10 m/s @ 1 kPa).**

The D1200SS-3 Series dampers are ideal for high humidity, mildly corrosive or, with optional Type 316 construction, more severe environment applications where building codes require a fire damper for the protection of ductwork penetrations in walls that have a fire resistance rating of up to 4 hours.

The D1200SS-3 Series is classified for use in dynamic "fans on" systems where the HVAC system remains operative in the event of a fire alarm. Damper closure under airflow is assured.

The D1200SS-3 Series has been especially designed and tested to provide premium performance. Airfoil blade design and elimination of blade sills, top and bottom, provide a low pressure drop design.

The D1200SS-3 Series features the industry proven over-center knee-lock design with high torque spring/fusible link closure.

Unique, inter-locking double skin blade design provides flame and smoke seal under fire conditions.

The D1200SS-3 is supplied as standard with an internal crank arm and locking screw which holds the damper in the fully open position, but may also be used for system balancing if required.

STANDARD SPECIFICATION:

- Frame:** 5" x 7/8" x 16 ga. (127 x 22 x 1.6) stainless steel hat channel.
- Blades:** 14 ga. (2.0) equivalent stainless steel formed airfoil on 5 1/2" (140) centers. Opposed blade action.
- Linkage:** Concealed in frame. 12 ga. (2.7) stainless steel.
- Bearings:** 1/2" (13) dia. sintered stainless steel.
- Axles:** 1/2" (13) dia. stainless steel double bolted to blades.
- Jackshaft:** 1/2" (13) dia. stainless steel. CCW rotation to open. Internal locking quadrant is factory installed.
- Fusible Link:** 165°F (74°C) standard.
- Minimum Size:** Vertical mount only: 8" x 8" (203 x 203).
- Maximum Size:** Single Section
Vertical mount only: 36" x 48" (914 x 1219).
Multiple Section Assembly
Vertical mount only: 60" x 96" (1524 x 2438) (Individual sections not to exceed 30" x 48" [762 x 1219]).

Dampers with duct heights less than 8" require a Type 'B' sleeve enclosure (Model D1202SS-3). Units less than 8" (203) in width only, or in both width and height, require a Type 'C' enclosure (Model D1203SS-3).

BASE MODEL SELECTION:

- D1200SS-3** Less sleeve.
- D1201SS-3** Standard factory sleeve 16" long x 20 ga. (406 x 1.0).
- D1201SS-3** Non-standard sleeve. Specify _____ length _____ ga. Available up to 36" (914) dependent upon wall thickness and 10 through 20 ga. (3.5 through 1.0).

CONSTRUCTION TYPE:

- 304** Type 304 Stainless Steel construction (Standard)
- 316** Type 316 Stainless Steel construction (Optional)

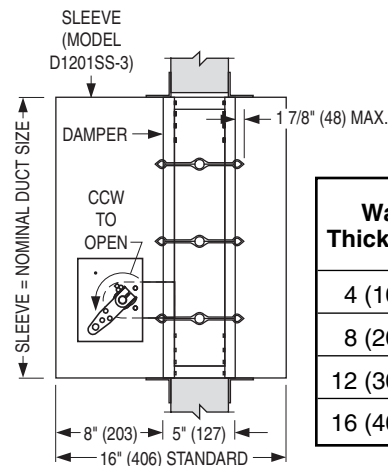
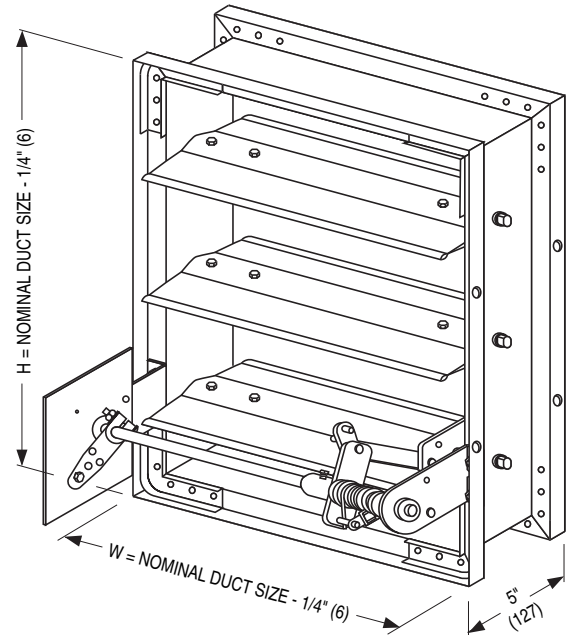

Wall Thickness	Minimum Sleeve Length
4 (102)	16 (406)
8 (203)	20 (508)
12 (305)	24 (610)
16 (406)	28 (711)

OPTIONS:

- SMP** Side mounting plate
 - MLS-300** Position indicator switch pack
 - JSS** Flexible stainless steel jamb seals
 - QS1** Quick-set retaining angle (one side)
 - QS2** Quick-set retaining angles (two sides)
- Note:** QS1 and QS2 are galvanized steel.
- Special features** _____

For installation instructions, see IOM-MBSSFDINST.

Dimensions are in inches (mm).

SCHEDULE TYPE:				
PROJECT:				
ENGINEER:	DATE	B SERIES	SUPERSEDES	DRAWING NO.
CONTRACTOR:	4 - 3 - 13	1200	1 - 1 - 12	D1200SS-3-1



DYNAMIC STAINLESS STEEL MULTI-BLADE FIRE DAMPER
 FOR USE IN DYNAMIC OR STATIC SYSTEMS
 HIGH PERFORMANCE • AIRFOIL BLADE
 3 HR. LABEL • VERTICAL MOUNT
MODEL: D1202SS-3 (TYPE B SLEEVE ENCLOSURE)



FOR DUCTS UNDER 8" (203) IN HEIGHT AND 8" (203) OR MORE IN WIDTH
QUALIFICATIONS:

- **UL 555 & CAN/ULC-S112 CLASSIFIED DYNAMIC FIRE DAMPER** 3 hr. Label (File # R9492).
- **Meets NFPA 80, 90A and 101 as well as IBC and NBC (Canada) Building Code requirements.**
- **California State Fire Marshal Listing No. 03225-0935:0101.**
- **City of New York. MEA# 366-03-M.**
- **Maximum velocity 2000 fpm @ 4" w.g. (10 m/s @ 1 kPa).**

The D1200SS-3 Series dampers are ideal for high humidity, mildly corrosive or, with optional Type 316 construction, more severe environment applications where building codes require a fire damper for the protection of ductwork penetrations in walls that have a fire resistance rating of up to 4 hours.

The D1200SS-3 Series is classified for use in dynamic "fans on" systems where the HVAC system remains operative in the event of a fire alarm. Damper closure under airflow is assured.

The D1200SS-3 Series has been especially designed and tested to provide premium performance. Airfoil blade design and elimination of blade sills, top and bottom, provide a low pressure drop design.

The D1200SS-3 Series features the industry proven over-center knee-lock design with high torque spring/fusible link closure.

Unique, inter-locking double skin blade design provides flame and smoke seal under fire conditions.

The D1202SS-3 is supplied as standard with an internal crank arm and locking screw which holds the damper in the fully open position, but may also be used for system balancing if required.

STANDARD SPECIFICATION:

- Frame:** 5" x 7/8" x 16 ga. (127 x 22 x 1.6) stainless steel hat channel.
- Blades:** 14 ga. (2.0) equivalent stainless steel formed airfoil on 5 1/2" (140) centers. Opposed blade action.
- Linkage:** Concealed in frame. 12 ga. (2.7) stainless steel.
- Bearings:** 1/2" (13) dia. sintered stainless steel.
- Axles:** 1/2" (13) dia. stainless steel double bolted to blades.
- Jackshaft:** 1/2" (13) dia. stainless steel. CCW rotation to open. Internal locking quadrant is factory installed.
- Fusible Link:** 165°F (74°C) standard.
- Min. Duct Size:** Vertical mount only: 8" x 4" (203 x 102). (Overall damper height is 8" [203]).
- Max. Duct Size:** Single Section
Vertical mount only: 36" x 7 1/2" (914 x 191).
Multiple Section Assembly
Vertical mount only: 60" x 7 1/2" (1524 x 191) (Individual section width not to exceed 30" [762]).

Units less than 8" (203) in width only, or in both width and height, require a Type 'C' enclosure (Model D1203SS-3).

BASE MODEL SELECTION:

- D1202SS-3** Standard factory sleeve 16" long x 20 ga. (406 x 1.0).
- D1202SS-3** Non-standard sleeve. Specify _____ length _____ ga. Available up to 36" (914) dependent upon wall thickness and 10 through 20 ga. (3.5 through 1.0).

CONSTRUCTION TYPE:

- 304** Type 304 Stainless Steel construction (Standard)
- 316** Type 316 Stainless Steel construction (Optional)

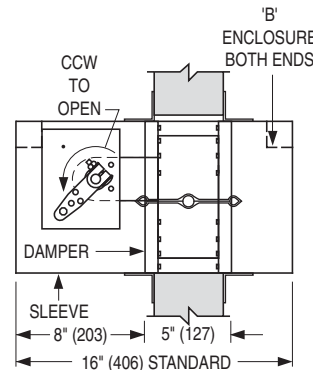
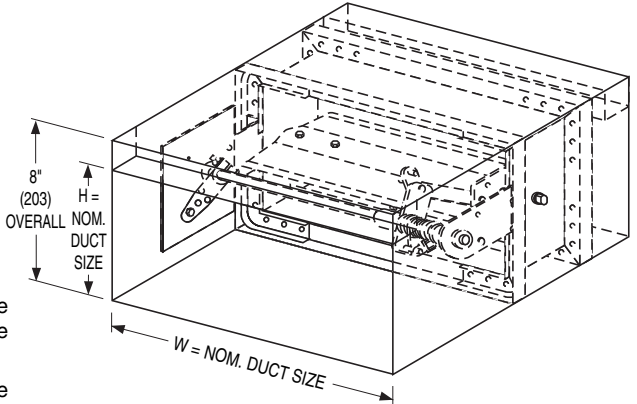

Wall Thickness	Minimum Sleeve Length
4 (102)	16 (406)
8 (203)	20 (508)
12 (305)	24 (610)
16 (406)	28 (711)

OPTIONS:

- MLS-300** Position indicator switch pack
 - JSS** Flexible stainless steel jamb seals
 - QS1** Quick-set retaining angle (one side)
 - QS2** Quick-set retaining angles (two sides)
- Note:** QS1 and QS2 are galvanized steel.
- Special features** _____

For installation instructions, see IOM-MBSSFDINST.

Dimensions are in inches (mm).

SCHEDULE TYPE:				
PROJECT:				
ENGINEER:	DATE	B SERIES	SUPERSEDES	DRAWING NO.
CONTRACTOR:	4 - 3 - 13	1200	1 - 1 - 12	D1200SS-3-2



DYNAMIC STAINLESS STEEL MULTI-BLADE FIRE DAMPER
 FOR USE IN DYNAMIC OR STATIC SYSTEMS
 HIGH PERFORMANCE • AIRFOIL BLADE
 3 HR. LABEL • VERTICAL MOUNT
 ROUND DUCT CONNECTION
MODEL: D1203SS-3 (TYPE C SLEEVE ENCLOSURE)



QUALIFICATIONS:

- **UL 555 & CAN/ULC-S112 CLASSIFIED DYNAMIC FIRE DAMPER 3 hr. Label (File # R9492).**
- **Meets NFPA 80, 90A and 101 as well as IBC and NBC (Canada) Building Code requirements.**
- **California State Fire Marshal Listing No. 03225-0935:0101.**
- **City of New York. MEA# 366-03-M.**
- **Maximum velocity 2000 fpm @ 4" w.g. (10 m/s @ 1 kPa).**

The D1200SS-3 Series dampers are ideal for high humidity, mildly corrosive or, with optional Type 316 construction, more severe environment applications where building codes require a fire damper for the protection of ductwork penetrations in walls that have a fire resistance rating of up to 4 hours.

The D1200SS-3 Series is classified for use in dynamic "fans on" systems where the HVAC system remains operative in the event of a fire alarm. Damper closure under airflow is assured.

The D1200SS-3 Series has been especially designed and tested to provide premium performance. Airfoil blade design and elimination of blade sills, top and bottom, provide a low pressure drop design.

The D1200SS-3 Series features the industry proven over-center knee-lock design with high torque spring/fusible link closure.

Unique, inter-locking double skin blade design provides flame and smoke seal under fire conditions.

The D1203SS-3 is supplied as standard with an internal crank arm and locking screw which holds the damper in the fully open position, but may also be used for system balancing if required.

STANDARD SPECIFICATION:

- Frame:** 5" x 7/8" x 16 ga. (127 x 22 x 1.6) stainless steel hat channel.
- Blades:** 14 ga. (2.0) equivalent stainless steel formed airfoil on 5 1/2" (140) centers. Opposed blade action.
- Linkage:** Concealed in frame. 12 ga. (2.7) stainless steel.
- Bearings:** 1/2" (13) dia. sintered stainless steel.
- Axles:** 1/2" (13) dia. stainless steel double bolted to blades.
- Jackshaft:** 1/2" (13) dia. stainless steel. CCW rotation to open. Internal locking quadrant is factory installed.
- Fusible Link:** 165°F (74°C) standard.
- Min. Duct Size:** Vertical mount only: 4" (102) diameter. (Overall damper size is 8" x 8" [203 x 203] min.).
- Max. Duct Size:** Single Section
Vertical mount only: 34" (864) diameter.
Multiple Section Assembly
Vertical mount only: 58" (1473) diameter (Individual sections not to exceed 28" [711] dia. duct size).

BASE MODEL SELECTION:

- D1203SS-3** Standard factory sleeve 16" long x 20 ga. (406 x 1.0).
- D1203SS-3** Non-standard sleeve. Specify _____ length ____ ga. Available up to 36" (914) dependent upon wall thickness and 10 through 20 ga. (3.5 through 1.0).

CONSTRUCTION TYPE:

- 304** Type 304 Stainless Steel construction (Standard)
- 316** Type 316 Stainless Steel construction (Optional)

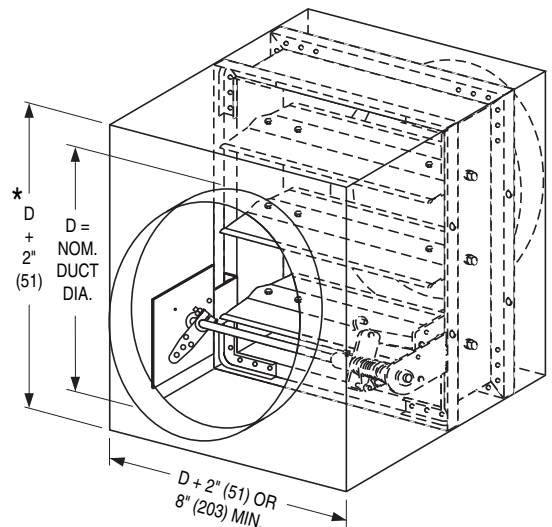

* or 8" (203) min.

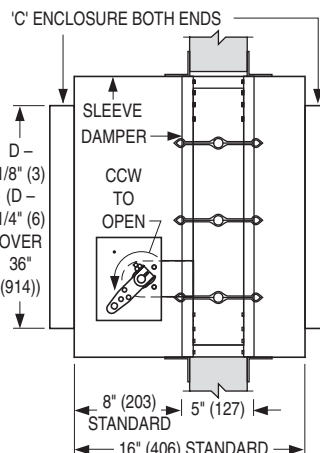

Wall Thickness	Minimum Sleeve Length
4 (102)	16 (406)
8 (203)	20 (508)
12 (305)	24 (610)
16 (406)	28 (711)

OPTIONS:

- MLS-300** Position indicator switch pack
 - JSS** Flexible stainless steel jamb seals
 - QS1** Quick-set retaining angle (one side)
 - QS2** Quick-set retaining angles (two sides)
- Note:** QS1 and QS2 are galvanized steel.
- Special features** _____

For installation instructions, see IOM-MBSSFDINST.

Dimensions are in inches (mm).

SCHEDULE TYPE:				
PROJECT:				
ENGINEER:	DATE	B SERIES	SUPERSEDES	DRAWING NO.
CONTRACTOR:	4 - 3 - 13	1200	1 - 1 - 12	D1200SS-3-3



DYNAMIC STAINLESS STEEL MULTI-BLADE FIRE DAMPER
 FOR USE IN DYNAMIC OR STATIC SYSTEMS
 HIGH PERFORMANCE • AIRFOIL BLADE
 3 HR. LABEL • VERTICAL MOUNT
 SQUARE, RECT. OR OVAL DUCT CONNECTION
MODEL: D1203SS-3 (TYPE C SLEEVE ENCLOSURE)



QUALIFICATIONS:

- **UL 555 & CAN/ULC-S112 CLASSIFIED DYNAMIC FIRE DAMPER 3 hr. Label (File # R9492).**
- **Meets NFPA 80, 90A and 101 as well as IBC and NBC (Canada) Building Code requirements.**
- **California State Fire Marshal Listing No. 03225-0935:0101.**
- **City of New York. MEA# 366-03-M.**
- **Maximum velocity 2000 fpm @ 4" w.g. (10 m/s @ 1 kPa).**

The D1200SS-3 Series dampers are ideal for high humidity, mildly corrosive or, with optional Type 316 construction, more severe environment applications where building codes require a fire damper for the protection of ductwork penetrations in walls that have a fire resistance rating of up to 4 hours.

The D1200SS-3 Series is classified for use in dynamic "fans on" systems where the HVAC system remains operative in the event of a fire alarm. Damper closure under airflow is assured.

The D1200SS-3 Series has been especially designed and tested to provide premium performance. Airfoil blade design and elimination of blade sills, top and bottom, provide a low pressure drop design.

The D1200SS-3 Series features the industry proven over-center knee-lock design with high torque spring/fusible link closure.

Unique, inter-locking double skin blade design provides flame and smoke seal under fire conditions.

The D1203SS-3 is supplied as standard with an internal crank arm and locking screw which holds the damper in the fully open position, but may also be used for system balancing if required.

STANDARD SPECIFICATION:

- Frame:** 5" x 7/8" x 16 ga. (127 x 22 x 1.6) stainless steel hat channel.
- Blades:** 14 ga. (2.0) equivalent stainless steel formed airfoil on 5 1/2" (140) centers. Opposed blade action.
- Linkage:** Concealed in frame. 12 ga. (2.7) stainless steel.
- Bearings:** 1/2" (13) dia. sintered stainless steel.
- Axles:** 1/2" (13) dia. stainless steel double bolted to blades.
- Jackshaft:** 1/2" (13) dia. stainless steel. CCW rotation to open. Internal locking quadrant is factory installed.
- Fusible Link:** 165°F (74°C) standard.
- Min. Duct Size:** Vertical mount only: 4" x 4" (102 x 102). (Overall damper size is 8" x 8" [203 x 203] min.).
- Max. Duct Size:** Single Section
Vertical mount only: 34" x 46" (864 x 1168).
Multiple Section Assembly
Vertical mount only: 58" x 94" (1473 x 2388) (Individual sections not to exceed 28" x 46" [711 x 1168] duct size).

BASE MODEL SELECTION:

- D1203SS-3** Standard factory sleeve 16" long x 20 ga. (406 x 1.0).
- D1203SS-3** Non-standard sleeve. Specify _____ length _____ ga. Available up to 36" (914) dependent upon wall thickness and 10 through 20 ga. (3.5 through 1.0).

CONSTRUCTION TYPE:

- 304** Type 304 Stainless Steel construction (Standard)
- 316** Type 316 Stainless Steel construction (Optional)

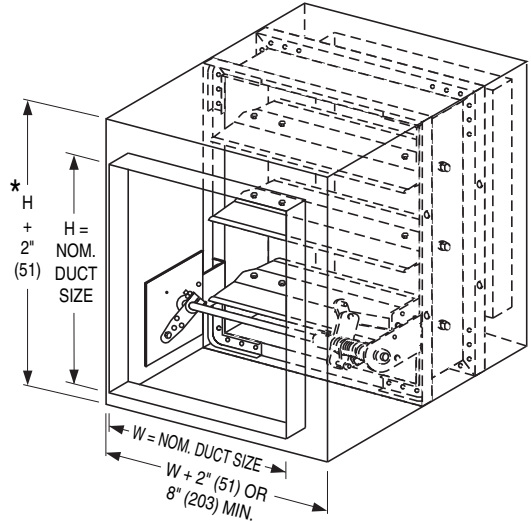

* or 8" (203) min.

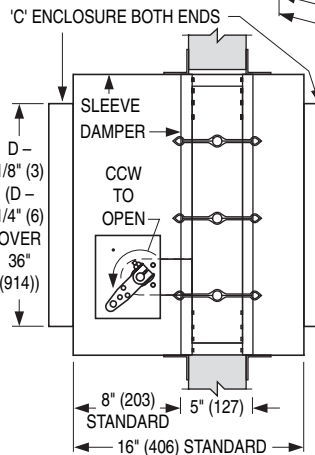
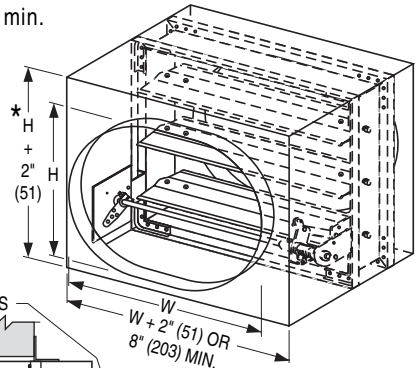

Wall Thickness	Minimum Sleeve Length
4 (102)	16 (406)
8 (203)	20 (508)
12 (305)	24 (610)
16 (406)	28 (711)

OPTIONS:

- MLS-300** Position indicator switch pack
- JSS** Flexible stainless steel jamb seals
- QS1** Quick-set retaining angle (one side)
- QS2** Quick-set retaining angles (two sides)

Note: QS1 and QS2 are galvanized steel.

Special features _____
 For installation instructions, see IOM-MBSSFDINST.

Dimensions are in inches (mm).

SCHEDULE TYPE:				
PROJECT:				
ENGINEER:	DATE	B SERIES	SUPERSEDES	DRAWING NO.
CONTRACTOR:	4 - 3 - 13	1200	1 - 1 - 12	D1200SS-3-4



DYNAMIC STAINLESS STEEL MULTI-BLADE FIRE DAMPER
 FOR USE IN DYNAMIC OR STATIC SYSTEMS
 HIGH PERFORMANCE • AIRFOIL BLADE
 1 1/2 HR. LABEL • VERTICAL MOUNT
 SQUARE, RECT. OR OVAL DUCT CONNECTION
MODEL: D1203SS (TYPE C SLEEVE ENCLOSURE)



QUALIFICATIONS:

- **UL 555 & CAN/ULC-S112 CLASSIFIED DYNAMIC FIRE DAMPER 1 1/2 hr. Label (File # R9492).**
- **Meets NFPA 80, 90A and 101 as well as IBC and NBC (Canada) Building Code requirements.**
- **California State Fire Marshal Listing No. 03225-0935:0101.**
- **City of New York. MEA# 366-03-M.**
- **Maximum velocity 2000 fpm @ 4" w.g. (10 m/s @ 1 kPa).**

The D1200SS Series dampers are ideal for high humidity or mildly corrosive applications where building codes require a fire damper for the protection of ductwork penetrations in walls that have a fire resistance rating of up to 2 hours.

The D1200SS Series is classified for use in dynamic "fans on" systems where the HVAC system remains operative in the event of a fire alarm. Damper closure under airflow is assured.

The D1200SS Series has been especially designed and tested to provide premium performance. Airfoil blade design and elimination of blade sills, top and bottom, provide a low pressure drop design.

The D1200SS Series features the industry proven over-center knee-lock design with high torque spring/fusible link closure.

Unique, inter-locking double skin blade design provides flame and smoke seal under fire conditions.

The D1203SS is supplied as standard with an internal crank arm and locking screw which holds the damper in the fully open position, but may also be used for system balancing if required.

The D1203SS is available in either Type 304 or 316 stainless steel.

STANDARD SPECIFICATION:

- Frame:** 5" x 7/8" x 16 ga. (127 x 22 x 1.6) stainless steel hat channel.
- Blades:** 14 ga. (2.0) equivalent stainless steel formed airfoil on 5 1/2" (140) centers. Opposed blade action.
- Linkage:** Concealed in frame. 12 ga. (2.7) stainless steel.
- Bearings:** 1/2" (13) dia. sintered stainless steel.
- Axles:** 1/2" (13) dia. stainless steel double bolted to blades.
- Jackshaft:** 1/2" (13) dia. stainless steel. CCW rotation to open. Internal locking quadrant is factory installed.
- Fusible Link:** 165°F (74°C) standard.
- Min. Duct Size:** Vertical mount only: 4" x 4" (102 x 102). (Overall damper size is 8" x 8" [203 x 203] min.).
- Max. Duct Size:** Single Section
Vertical mount only: 34" x 46" (864 x 1168).
Multiple Section Assembly
Vertical mount only: 70" x 94" (1778 x 2388) or 142" x 46" (3607 x 1168).

BASE MODEL SELECTION:

- D1203SS** Standard factory sleeve 16" long x 20 ga. (406 x 1.0) (18 ga. [1.3] for dampers over 84" [2134] in width).
- D1203SS** Non-standard sleeve. Specify _____ length _____ ga. Available up to 36" (914) dependent upon wall thickness and 10 through 20 ga. (3.5 through 1.0).

CONSTRUCTION TYPE:

- 304** Type 304 Stainless Steel construction (Standard)
- 316** Type 316 Stainless Steel construction (Optional)

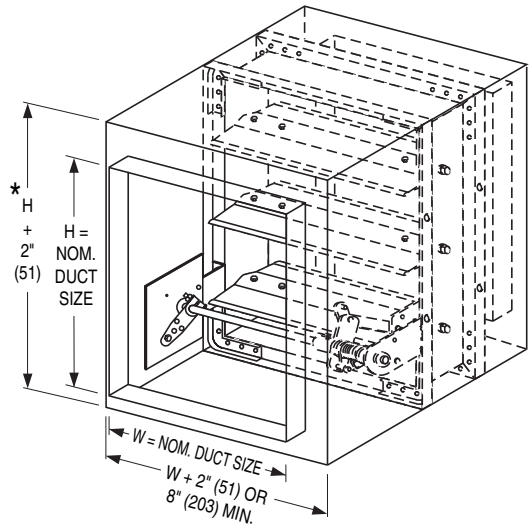

* or 8" (203) min.

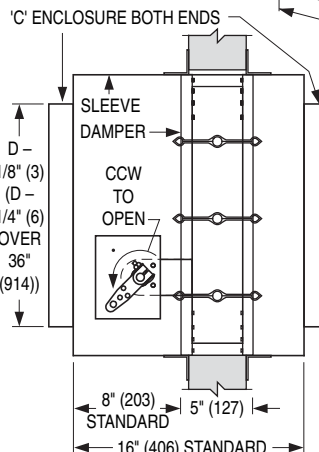
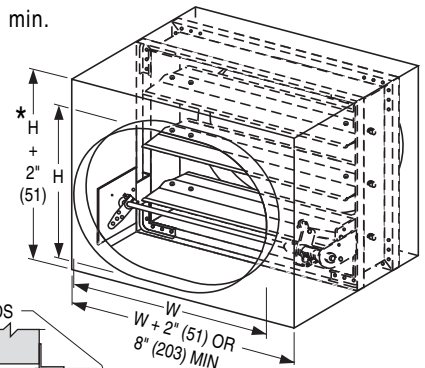

Wall Thickness	Minimum Sleeve Length
4 (102)	16 (406)
8 (203)	20 (508)
12 (305)	24 (610)
16 (406)	28 (711)

OPTIONS:

- MLS-300** Position indicator switch pack
- JSS** Flexible stainless steel jamb seals
- QS1** Quick-set retaining angle (one side)
- QS2** Quick-set retaining angles (two sides)

Note: QS1 and QS2 are galvanized steel.

- Special features** _____
- For installation instructions, see IOM-MBSSFDINST.

Dimensions are in inches (mm).

SCHEDULE TYPE:				
PROJECT:				
ENGINEER:	DATE	B SERIES	SUPERSEDES	DRAWING NO.
CONTRACTOR:	4 - 3 - 13	1200	1 - 1 - 12	D1200SS-4

**"QUICK-SET" RETAINING ANGLES BOTH SIMPLIFY AND SPEED INSTALLATION,
SAVING BOTH TIME AND MONEY.**

BENEFITS:

- One piece angles are fastened together in the corners. Only two sets of angles to handle per damper (rather than four separate angles per side).
- Angles are shipped with damper - no sorting or matching.
- Provided with pre-drilled fastening holes on 2" (51) centers to ensure correct angle/sleeve attachment.
- Factory fabricated by Nailor to suit the individual fire damper.
- Reduced cost when compared to conventional retaining angles.
- Dampers can ship directly to the job site complete with all necessary installation sheet metal hardware (saves on double handling at contractor's shop).
- Help ensure a correct installation as per U.L. approved installation instructions.

The majority of installing contractors view fire damper installation as a costly time consuming and troublesome procedure. Eight conventional angles must be custom fabricated for each damper either in a sheet metal shop or at the job site and sized to suit each individual damper. Invariably, they are mislaid or lost and must be matched to each factory supplied damper.

The Nailor "Quick-Set" solution solves the majority of problems. They are pre-formed to fit and ship with the individual damper for ultimate convenience. "Quick-Set" angles are supplied with correctly spaced pre-drilled screw-holes to ensure a quick, easy and accurate installation for all integral sleeve Nailor fire and combination fire/smoke dampers - no measuring required.

"Quick-Set" retaining angles provide the "complete" installation package. Simple, fast, convenient.

MODELS:

Nailor "Quick-Set" retaining angles are an accessory option for all dampers ordered with factory sleeves.

QS2: Two sides (pair). For standard installations where angles are installed on both sides of the fire partition.

QS1: One side (single set). For use in single side retaining angle installations and with grille mount and "out of wall" damper models.

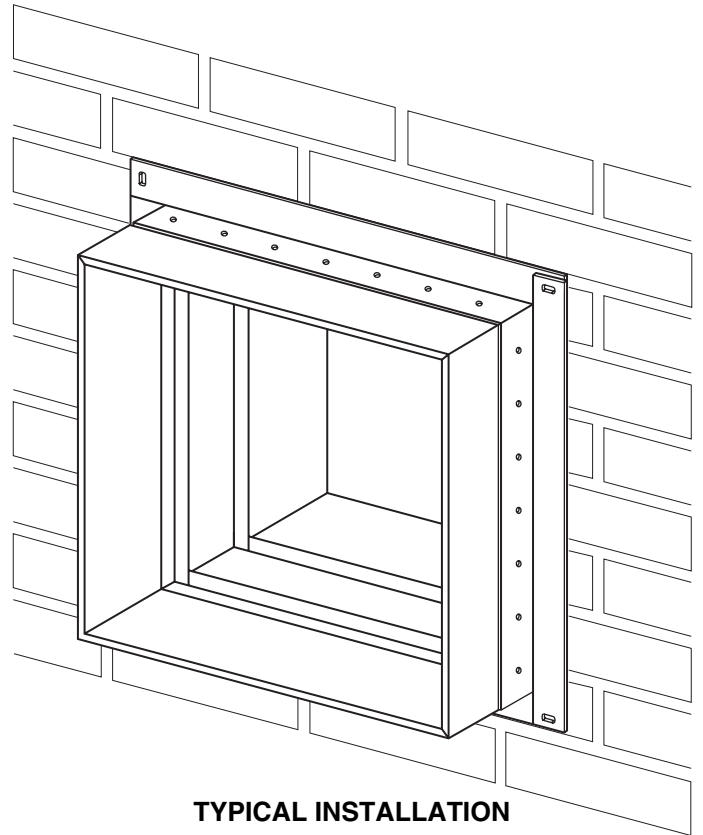

TYPICAL INSTALLATION

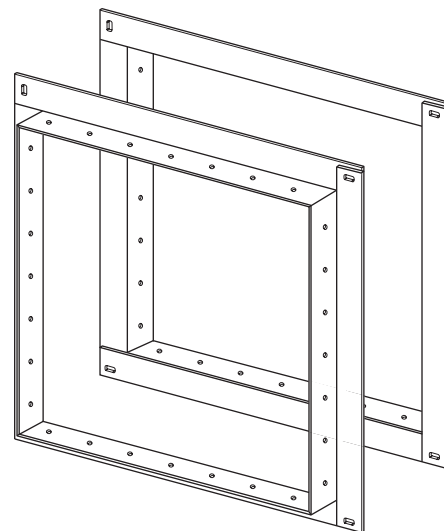

**TYPICAL PAIR OF PRE-ASSEMBLED
QUICK-SET' RETAINING ANGLES**

SCHEDULE TYPE:		Page 1 of 2			
PROJECT:		Dimensions are in inches (mm).			
ENGINEER:		DATE	B SERIES	SUPERSEDES	DRAWING NO.
CONTRACTOR:		2 - 26 - 09	FD-ACC	6 - 5 - 03	QSRA

"QUICK-SET" RETAINING ANGLES
FOR ALL SLEEVED FIRE AND
COMBINATION FIRE/SMOKE DAMPERS
MODELS: QS1 AND QS2

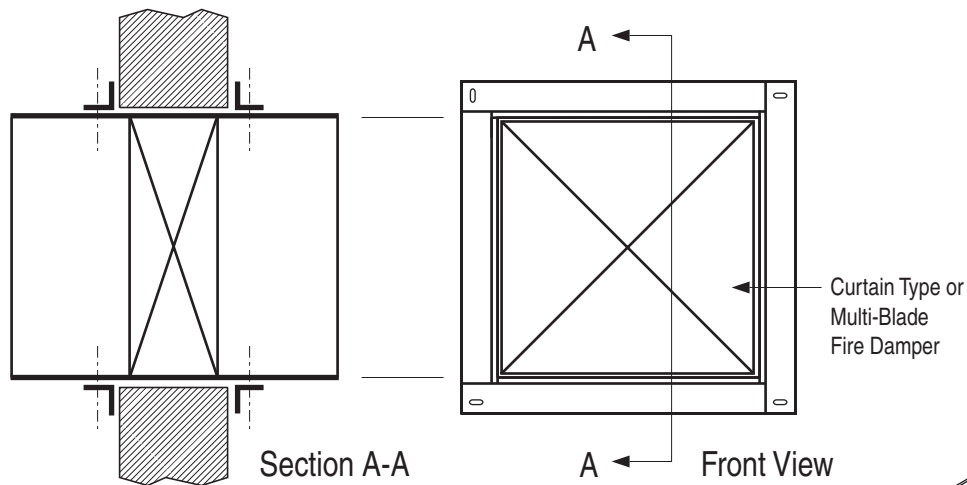

FIGURE 1. TYPICAL TWO SIDED INSTALLATION.

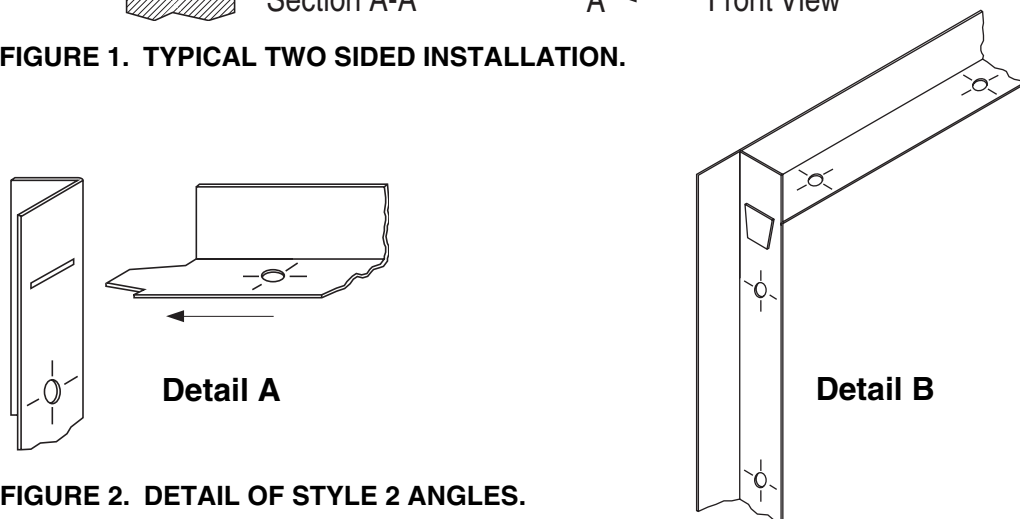

FIGURE 2. DETAIL OF STYLE 2 ANGLES.

APPLICATION:

The Nailor Quick-Set Retaining Angle System may be used in lieu of conventional retaining angles on all Nailor Fire and Combination Fire/Smoke Dampers.

Quick-Set angles are supplied in one of two styles, dependent upon fire resistance label, damper size and installation method.

Style 1: 1 1/2" x 1 1/2" x 20 ga. (38 x 38 x 1.0) Four sides are connected together with rivets in three corners.

Standard for the majority of applications with the following limitations:

- 1 1/2 hour label fire dampers.
- Maximum Size: 36" x 36" (914 x 914)
- Two sided installation only

Style 2: 1 1/2" x 1 1/2" x 16 ga. (38 x 38 x 1.6) Slot and tab design. The retaining angle assembly for each side has four angles, each with a tab end and a slot end (Detail A).

The tabs are to be inserted into the slots and knocked down either before or after fastening to the sleeve (Detail B).

- 1 1/2 or 3 hour label fire dampers
- Maximum Size: 90" x 48" (2286 x 1219) or 48" x 90" (1219 x 2286)
- Single side (1 1/2 hour only. Refer to Single Side Retaining Angles Supplementary Installation Instructions for size limitations) or two sided installation

Refer to the Following Installation Instructions:

Quick-Set Retaining Angles	FDQSRA
Curtain Type Fire Dampers (D)0100 & (D)0500	FDINST
Curtain Type Fire Dampers 0200 & 0500 Thinline	FDTINST
Multi-Blade Fire Dampers 1200 & 1250	MBFDINST
Combination Fire/Smoke Dampers 1220	1220INST
Combination Fire/Smoke Dampers 1270	1270INST
Single Side Retaining Angles	FDSSRAINST

SCHEDULE TYPE:	Page 2 of 2			
PROJECT:	Dimensions are in inches (mm).			
ENGINEER:	DATE	B SERIES	SUPERSEDES	DRAWING NO.
CONTRACTOR:	2 - 26 - 09	FD-ACC	5 - 5 - 03	QSRA

PERFORMANCE DATA:

MODEL SERIES: D1200SS - 1 1/2 HOUR LABEL AND D1200SS-3 - 3 HOUR LABEL

PRESSURE DROP:

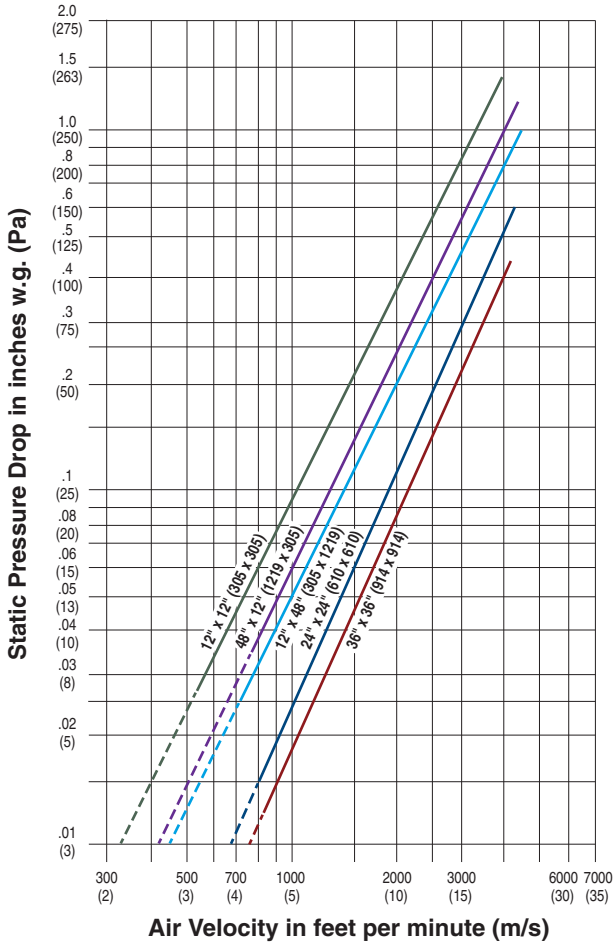

Pressure drop tested per AMCA Standard 500-D, Figure 5.3. Data corrected to standard air density of 0.075 lbs./ft.³.

D1200SS Series Maximum Performance Ratings	
UL 555S Fire Rating	1 1/2 Hour
Maximum Velocity	2000 fpm (10 m/s)
Maximum Pressure	4 in. w.g. (1 kPa)

D1200SS-3 Series Maximum Performance Ratings	
UL 555S Fire Rating	3 Hour
Maximum Velocity	2000 fpm (10 m/s)
Maximum Pressure	4 in. w.g. (1 kPa)

MULTI-BLADE FIRE DAMPERS

HOW TO SPECIFY

SUGGESTED SPECIFICATION:

Provide and install, as shown on plans and/or schedules, Stainless Steel Multi-Blade Dynamic Fire Dampers as manufactured by Nailor Industries, Inc. which meet or exceed the following criteria: Fire dampers shall meet the requirements of NFPA 80, 90A and 101 and shall be manufactured, tested and labeled in accordance with UL 555. Each damper shall bear a UL fire resistance rating label of **(specifier select rating)** 1 1/2 hours **or** 3 hours, and in addition, a label verifying the airflow and closure pressure ratings of 2000 fpm (10 m/s) at 4" w.g. (1 kPa) static pressure differential, as established by the Dynamic Closure Test. Each fire damper shall also be marked with the words "For use in dynamic systems". Dampers marked "For use in static systems only" are not acceptable.

Frame shall be constructed of 16 ga. (1.6) **(specifier to select)** Type 304 **or** Type 316 Stainless Steel hat channel with mitered corners reinforced with die-formed corner gussets for strength. Blades shall be 14 ga. (2.0) equivalent stainless steel formed double skin, airfoil design, on 5 1/2" (140) centers. Dampers shall be of opposed blade configuration with an interlocking blade design. Blade seals are not acceptable. Blade axles shall be stainless steel, double bolted at each end of blade to provide positive locking connection. Hex, square friction-fit or press-fit axles are not acceptable. Bearings shall be sintered stainless steel type. Blade linkage shall be zero-maintenance, concealed in frame, out of airstream.

Each fire damper shall be complete with a **(specifier select temperature)** 165°F (74°C) **or** 212°F (100°C) UL Listed fusible link that will cause the damper to close and lock in closed position by means of an over center/knee lock linkage for assured closure. Fire dampers shall each include a stainless steel sleeve of appropriate length/gauge as field verified by contractor, with Nailor 'Quick-Set' retaining angles supplied by damper manufacturer to ensure proper installation in accordance with damper manufacturer's instructions. Each damper shall be supplied with an internal manual quadrant(s) for setting and locking of blades in desired position. Contractor shall provide and install an access door at each fire damper, of appropriate size to allow for inspection, testing and fusible link replacement. Data submitted for approval shall include confirmation of UL qualifications in addition to manufacturer's installation instructions. Each shipment of fire dampers shall include same installation instructions. Standard of acceptance shall be Nailor Model Series **(specifier to select)** D1200SS (1 1/2 hour label) **or** D1200SS-3 (3 hour label).

Dampers are an essential part of the fire protection system in a building. The NFPA recommends that fire dampers be tested periodically to verify the operational abilities of each installed damper. See NFPA 80, *Standard for Fire Doors and Other Opening Protectives*, for Operational and Periodic Inspection and Testing details.

CAUTION:

High torque helical spring under tension, ensure HVAC fans are turned off. Testing spring assisted fire dampers under airflow conditions is **NOT RECOMMENDED** and may severely damage or destroy ductwork. Use protective eyewear or safety glasses. Keep hands out of the blade path, as this can cause serious injury. Keep any hard objects or tools out of the blade path as they can damage the blades when closing.

Releasing of the fusible link

1. Using a suitable heat source, apply heat at a slightly higher temperature than the rating of the fusible link until the link melts. When applying the heat to the fusible link position the heat source in a manner so no heat is directed towards the spring as the excessive heat can negatively affect the spring performance.

AS SOON AS THE LINK HAS MELTED, THE SPRING WILL FORCE THE BLADES TO CLOSE INSTANTANEOUSLY. THE BLADE PATH MUST BE KEPT CLEAR.

Reloading the spring assembly

2. Loosen the jackshaft from the bolt on crank arm quadrant, located on the jackshaft side opposite of the spring assembly (A). Do not remove the bolt completely. See Detail 1.

3. Attach a pair of vise grips on the jackshaft (B) and turn upwards until the two pins on the spring assembly are at a distance at which the new fusible link can be installed (C). This is approximately 90° of rotation. See Detail 2.

Note: On smaller size dampers, two vise grips may be required to open the damper. Use one vice grip to open as much as the duct free area will allow, then set the second vise grips on the jackshaft per above. Unlock the first set of vise grips, remove and turn the second set upwards as free area will allow. Repeat as necessary.

4. Place the new fusible link over the two pins on the spring assembly (making sure temperature rating is visible) and locate in the pin grooves (C). See Detail 2.

Required Items:

- (1) Protective eyewear or safety glasses
- (1) Pair of work gloves
- (1) Suitable heat source
- (2) Vise grips
- (1) 1/2" (13) wrench
- (1) Needle nose pliers
- (1) Replacement "Globe" Fusible link per damper section, of the same temperature rating as the original link.



Detail 1



Detail 2

5. Manually open the damper to 100% full open position (D). See Detail 3.
6. Tighten the bolt on the crank arm (E). See Detail 3.

Reopening spring assisted fire dampers may be extremely difficult and in some cases, impossible. If it is determined that the damper is impossible or impractical to test or reopen, a thorough examination of the blade path is required to ensure that nothing will prevent the damper from closing. Common obstructions include: racked damper frames, retaining angle installation screws, construction debris and contaminants.

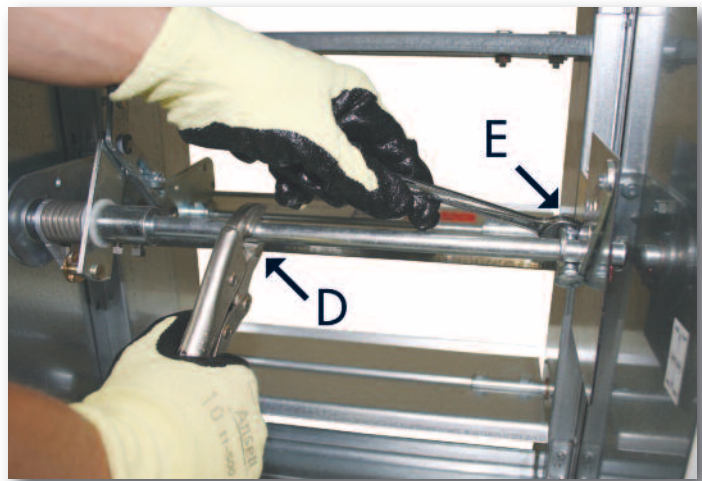

Detail 3

Periodic Inspection, Testing and Maintenance

Consult your local building code to verify whether there is a required maintenance and testing schedule. Most local jurisdictions reference NFPA 80 for Fire Dampers.

Per NFPA 80, each damper should be inspected 1 year after installation and then every 4 years, except for hospitals, where the frequency is every 6 years.

1. Remove any obstructions, dirt, rust, corrosion, or other observed conditions that could impede proper damper operation. Clean damper blades and other moving parts if necessary. Use of a mild detergent or solvents is recommended for any cleaning required.

2. Check closure springs. If damaged or defective, repair or replace.

3. Linkage and jackshaft bearing brackets should be lubricated with a dry lubricant (such as T.F.E. Dry Lube). Never use a regular lubricating oil on dampers, as it will attract dirt and grit. Blade linkage is concealed in the side jamb out of the airstream and is maintenance free. Bearings are self-lubricating oilite bronze (or stainless steel for -SS models).

4. If firing of the fusible link is not required by local code, cycle damper with its quadrant handle to verify that it fully opens and closes. HVAC fans should be shut down. Care should be exercised to ensure that such tests are performed safely and do not cause system damage.

5. All inspections and testing shall be documented indicating the location of the damper, date of inspection, name of inspector, deficiencies detected, and how deficiencies were corrected.

Receiving, Storage, Preparation

Upon delivery, inspect shipping containers and contents closely. Note any damages on freight carrier's delivery receipt.

Store dampers in a cool, dry and safe location in an orderly manner away from construction site, warehouse traffic, other materials, etc. Cover with plastic sheeting to protect from excessive moisture, dirt and debris.

Inspect dampers prior to installation. Dampers must be cleaned per procedures outlined in this document prior to installation if dirt, rust or corrosion is observed.

SPARE PARTS LIST		PART NUMBER
Fusible Links: Model 1200, 1250, 1290	165°F/74°C	B2-037
	212°F/100°C	B2-038

INSTALLATION INSTRUCTIONS

STAINLESS STEEL MULTI-BLADE FIRE DAMPERS

1 1/2 HOUR LABEL • VERTICAL MOUNTING ONLY

MODEL SERIES (D)1200-SS

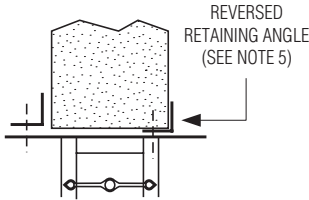

QUALIFICATIONS:

- **UL 555 & CAN/ULC-S112 CLASSIFIED FIRE DAMPER 1 1/2 hr. Label (File #'s R9492 & R19569).**
- **Meets NFPA 80, 90A and 101 as well as IBC & NBC (Canada) Building Code requirements.**



NOTES:

1. Installation shall be in accordance with the appropriate requirements of the National Fire Protection Association Standard NFPA 90A latest edition.
2. **Damper Sleeve:** Sleeve thickness must be equal to or thicker than the duct connected to it. Sleeve gauge requirements are listed in the SMACNA Fire, Smoke and Radiation Damper Installation Guide for HVAC Systems and in NFPA 90A. If a break-away style duct/sleeve connection is not used, damper sleeves up to 36" wide by 24" (914 x 610) high of not less than 16 gauge (1.61) galvanized or stainless steel, or larger sleeves of not less than 14 gauge (1.99) thick steel may be attached to the duct with screws or other types of mechanical fasteners. The maximum sleeve thickness for such rigid joints is 10 gauge (3.51).
The connecting duct shall not be continuous thru the wall or floor opening but shall terminate at the sleeve. Sleeves shall extend a maximum of 6" (152) on either side of the wall or floor opening or 16" (406) on a side intended for use with an actuator and/or an access door. The sleeves may extend 16" (406) on each side for use with an actuator on one side and an access door on the other side.

3. Break-away duct/sleeve connections:

- a. Rectangular ducts must use one or more of the following connections if the gauge is less than the requirement in note 2 for rigid connections:

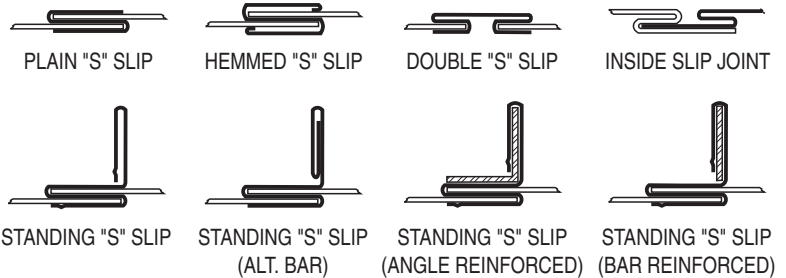

In addition:

- A maximum of two #10 sheet metal screws on each side and on the bottom, located in the center of the slip pocket and penetrating both sides of the slip pocket may be used.
- One of the above connections on the top and bottom joints with flat drive slip connections on the side joints may be used for dampers up to 20" (508) in height.



- b. Round or oval duct may be attached to the round or oval collar which is part of the damper/sleeve in the following manner:
 - Duct diameters 22" (559) and smaller must use three #10 sheet metal screws equally spaced around the circumference.
 - Duct diameters over 22" (559) up to and including 36" (914) may use five #10 sheet metal screws equally spaced around the circumference.
 - Duct diameters larger than 36" (914) wide or diameter may use eight #10 sheet metal screws equally spaced around the circumference.

Note: When optional sealing of these break-away connections is desired, the duct sealant shall be PA2084T Duct Sealant by Precision or water based DP1010 by Design Polymetrics.

- c. For the use of approved alternative Ductmate or TDC/TDF break-away connections, refer to the supplements noted on page 2.

4. **Damper/sleeve attachment:** Damper shall be secured to sleeve with 1/4" (6) long welds, 1/4" (6.35) dia. bolts and nuts or #10 sheet metal screws on both sides at 6" (152) on center and a maximum of 4" (102) from the corners of the damper on all four sides. For field assembled sleeves, the inner dimensions of the sleeve shall be equal to the outer dimensions of the damper.

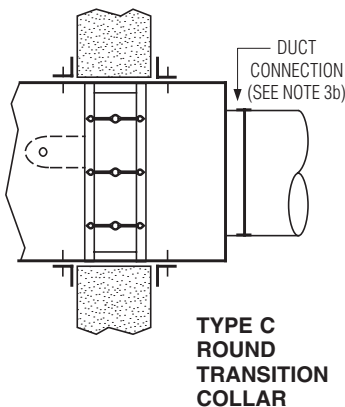
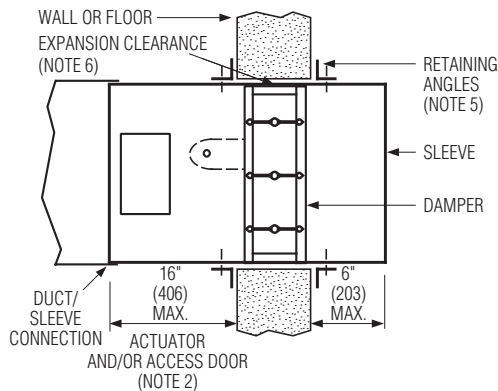

WARNING: STRONG SPRING UNDER TENSION ON ALL UNITS, KEEP HANDS CLEAR. IN ALL INSTALLATIONS ENSURE THAT OPERATING DRIVE SHAFT IS FREE FROM OBSTRUCTION TO ENSURE EASE OF OPERATION.

5. Retaining angles shall be a minimum of 1 1/2" x 1 1/2" x 16 gauge (38 x 38 x 1.61) steel for dampers up to 90" (2286) in width and up to 90" (2286) in height. For dampers exceeding these dimensions, the angles shall be a minimum of 2" x 2" x 10 gauge (51 x 51 x 3.51). Secure the retaining angles to the sleeve with 1/2" (12.7) long welds, 1/4" (6.35) dia. bolts and nuts or #10 sheet metal screws 8" (203) on center and 2" (51) maximum from corner of sleeve on all four sides. The retaining angles must lap the structural opening by 1" (25.4) minimum. When the ductwork terminates at the wall or floor, the retaining angles may be turned inwards, providing the opening size is increased by an amount equal to twice the combined thickness of the angle and the height of the screw or bolthead to maintain the required expansion clearance. Field fabricated retaining angles are not to be mechanically fastened at the corners.

6. Expansion clearance between the sleeve and wall or floor shall be a minimum of 1/8" per foot (3.18 per 305) of width or height of the sleeve. The maximum size of the opening shall be 2" (50.8) larger in either dimension than the allowable minimum size. For example; a sleeve dimension of 36" x 36" (914 x 914) shall have an opening size of 36 3/8" x 36 3/8" (924 x 924) minimum and 38 3/8" x 38 3/8" (975 x 975) maximum.

7. Maximum Size Limitations: The maximum Type A fire damper sizes are as follows:

Model Series			Single Section	Multiple Section
1200-SS (Static)	Vertical	(1 1/2 hr. label)	36" x 48" (914 x 1219)	144" x 96" (3658 x 2438)
D1200-SS (Dynamic)	Vertical	(1 1/2 hr. label)	36" x 48" (914 x 1219)	72" x 96" (1829 x 2438) or 144" x 48" (3658 x 1219)

Type B and C dampers have the same overall damper size but the connecting ducts are smaller due to the B or C enclosures. See Type B and Type C specification drawings for maximum duct sizes.

In cases when the openings are larger than specified in note 7, a UL tested and qualified steel mullion must be provided between assemblies (Refer to supplementary installation document FDSMINST). Mullion is for use in static applications only.

8. Actuators and accessories: Nailor multi-blade fire dampers are supplied with an internal locking quadrant as standard to hold damper blades in the open position. If MLS-300 position indicators are used, refer to the proper installation instructions for the MLS-300.

9. Multiple-section assemblies: In multiple assemblies of vertical dampers, the frames shall be joined together on both sides of the damper using 1/4" (6) long welds, 1/4" (6.35) dia. bolts and nuts, or #8 sheet metal screws. Maximum 6" (152) on center.

Multiple section vertical damper assemblies, over two sections wide, require a 10 ga. (3.51) x 5" (127) flat vertical mullion between one pair of sections (see Figure 1). When a minimum 16 ga. (1.6) sleeve is used and a left and right section are sleeved separately, the sleeve acts as the mullion, therefore no mullion is required. The sleeves shall be joined together on both sides of the damper using 1/4" (6) long welds, 1/4" (6.35) dia. bolts and nuts or #8 sheet metal screws. Maximum 6" (152) on center (see Figure 2).

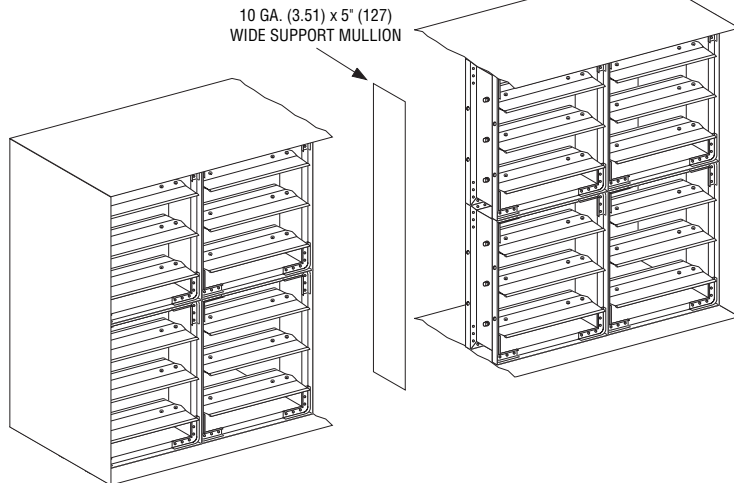

Figure 1. Single sleeve around outside and vertical mullion

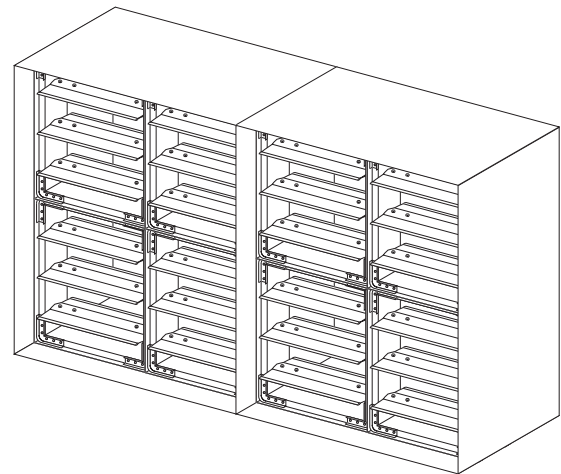

Figure 2. Two individually sleeved units (No mullion required)

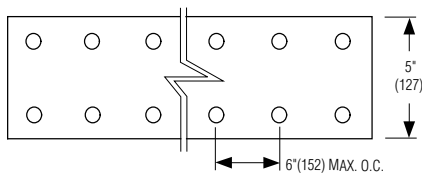

Figure 3. Flat Mullion

IMPORTANT:

- DO NOT CAST DAMPER IN PLACE.
- DO NOT FASTEN RETAINING ANGLES OR DAMPER DIRECTLY TO WALL OR FLOOR.
- DO NOT INSTALL DAMPER OUT OF SQUARE OR OUT OF FLAT.
- VERTICAL MOUNTING SHOWN ON MASONRY WALL.
- FOR INSTALLATION IN DRYWALL FRAMING, SEE DOC. FDSWSFINST.

REFER TO THE APPROPRIATE NAILOR INSTALLATION INSTRUCTION SUPPLEMENTS FOR THE FOLLOWING SPECIAL REQUIREMENTS:

- | | |
|---|------------|
| STEEL MULLIONS (for dampers in oversized wall openings) | FDSMINST |
| SINGLE SIDED RETAINING ANGLES | FDSSRAINST |
| STEEL AND WOOD STUD FRAMING | FDSWSFINST |
| CAVITY SHAFT WALL PARTITIONS | FDCSWINST |
| DUCTMATE BREAKAWAY CONNECTIONS | FDDMINST |
| TDC/TDF FLANGED DUCT CONNECTION | FDTDCFINST |
| QUICK-SET RETAINING ANGLES | FQDSRA |

Dimensions are in inches (mm).



Houston, Texas
Tel: 281-590-1172
Fax: 281-590-3086

Las Vegas, Nevada
Tel: 702-648-5400
Fax: 702-638-0400

Toronto, Canada
Tel: 416-744-3300
Fax: 416-744-3360

Calgary, Canada
Tel: 403-279-8619
Fax: 403-279-5035

APPLICATION:

This vertical fire damper installation is for metal stud framing in UL resistant cavity shaft wall designs (1 and 2 hr.) including Nos. U438, U469 and U497. It differs from conventional fire damper installations in that it requires retaining angles on one side of the wall only, which are fastened to the wall as well as the damper for opening sizes up to 48" W x 36" H (1219 x 914). Larger openings require retaining angles on both sides.

GENERAL INSTALLATION:

- 1. Expansion Clearance:** Opening in wall shall be a minimum 1/8" (3) per linear foot larger than overall size of damper and sleeve assembly in either dimension. Maximum opening not to exceed 1/8" (3) per foot plus two inches. Opening shall not be less than 1/4" (6) larger for any size damper and sleeve assembly.
- 2. Damper Sleeve:** Sleeve gauge shall be at least equal to the gauge of the duct as defined by the appropriate SMACNA duct construction standard and described in NFPA 90A when one or more of the following duct-sleeve connections are used (TDC/TDF breakaway, ductmate breakaway, plain "S" slip, hemmed "S" slip, standing "S" slip, reinforced standing "S" slip, inside slip joint, and double "S" slip.)

In addition, the following connections are acceptable:

- A.** On rectangular duct, a standing S slip connection, with two #10 sheet metal screws on each side and bottom of the joint and with duct sealant* applied to each connection, may be used.
- B.** On rectangular duct, a standing S slip connection on top and bottom joints and flat drive connections on side joints with duct sealant* applied to each connection, may be used for dampers 48" x 20" (1219 x 508) and smaller. Plain S and hemmed S slip connections can also be used in lieu of the standing S connections described above.
- C.** A round duct may be attached to the round adapter which is part of the damper sleeve in the following manner:
 - (a) Duct diameters 22" (559) and smaller must use three #10 sheet metal screws equally spaced around the circumference and with duct sealant* applied to the connection.
 - (b) Duct diameters over 22" (559) up to and including 36" (914) may use five #10 sheet metal screws equally spaced around the circumference and with duct sealant* applied to the connection.
 - (c) Duct diameters larger than 36" (914) wide or diameter may use eight #10 sheet metal screws equally spaced around the circumference.

*The duct sealant must be PA2084T Duct Sealant Adhesive as manufactured by Precision or water based DP1010 by Design Polymetrics.

- 3.** If any other duct-sleeve connections are used, sleeve shall be minimum of 16 gauge (1.6) for dampers up to 36" w x 24"h (914 x 610) and 14 gauge (1.9) if damper width exceeds 36" (914) or height exceeds 24" (610).
- 4. Damper/Sleeve Attachment:** Damper shall be secured to sleeve with 1/4" (6) long welds, 3/16" (5) steel rivets, 1/4" (6) bolts and nuts, #8 sheet metal screws, or 3/16" (5) buttonlocks on both sides at 6" (152) on center and 2" (51) maximum from the corner of the damper on all four sides. For field assembled sleeves, the inner dimensions of the sleeve shall be equal to the outer dimensions of the damper.

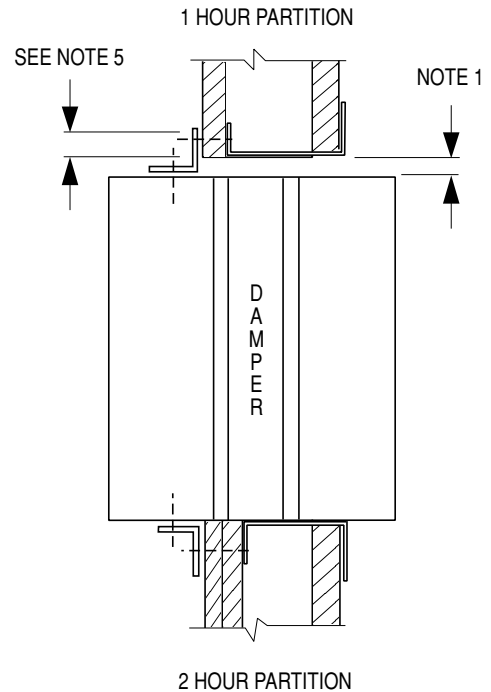

5. Retaining Angles:

- A.** Shall be a minimum of 1 1/2" x 1 1/2" x 16 gauge (38 x 38 x 1.61) and fastened with #10 bolts or screws, 1/2" (13) long welds, or 3/16" (5) rivets to sleeve at a maximum spacing of 8" (152) O.C. and not more than 2" (51) from each end with a minimum of two connections on each side, top and bottom (See Illustration).

Nailor 'Quick-Set' Retaining Angles can be used in lieu of conventional mounting angles. Retaining angles must overlap the structural opening by 1" (25) minimum.

- B.** Retaining angles screw to wall with #10 screws. Use a minimum of two fasteners per side, top and bottom 12" (305) O.C. maximum.

- 6.** See framing detail on next page for opening preparation. Refer to the appropriate installation supplements for the following requirements:

Ductmate Breakaway Connection	Doc. FDDMINST
Flange System Breakaway Connections	Doc. FDTDCFINST
'Quick-Set' Retaining Angles.	Doc. FDQSRA

- 7.** Refer to Underwriters Laboratories Inc. Fire Resistance Directory Vol. II for details on UL Design No. U438, U469 and U497.



**FRAMING DETAIL FOR ASSEMBLIES
(U438 AND U469)**

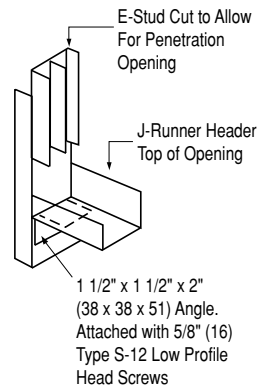
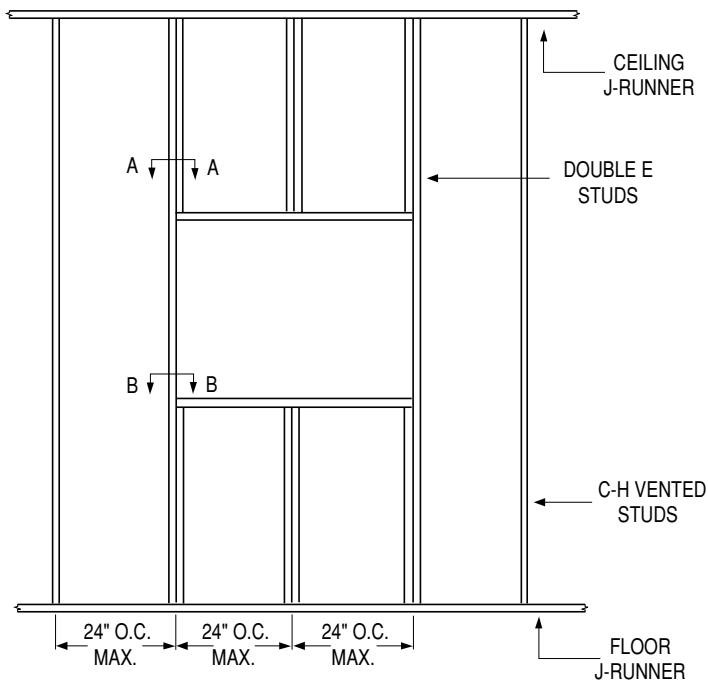

SECTION A-A

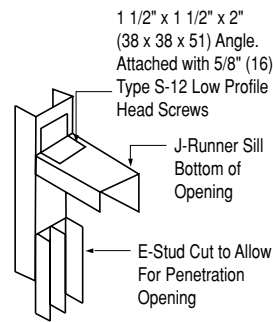

SECTION B-B

**FRAMING DETAIL FOR
ASSEMBLIES (U497)**

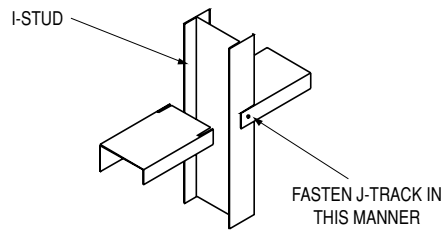
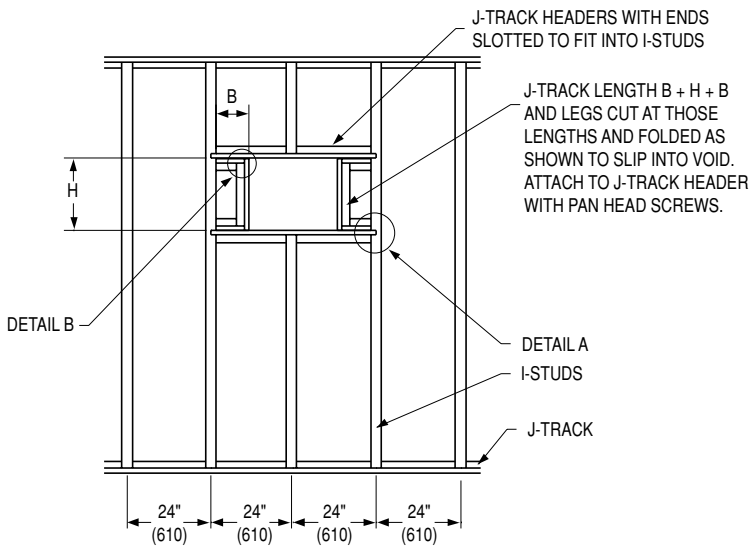

DETAIL A

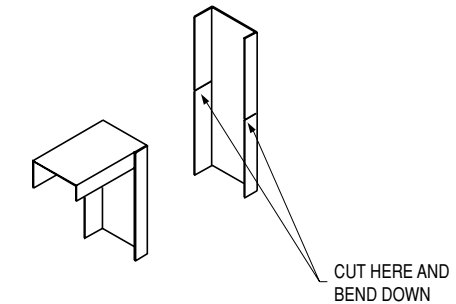

DETAIL B

Dimensions are in inches (mm).

Page 2 of 2



Houston, Texas
Tel: 281-590-1172
Fax: 281-590-3086

Las Vegas, Nevada
Tel: 702-648-5400
Fax: 702-638-0400

Toronto, Canada
Tel: 416-744-3300
Fax: 416-744-3360

Calgary, Canada
Tel: 403-279-8619
Fax: 403-279-5035

**"QUICK-SET" RETAINING ANGLES BOTH SIMPLIFY AND SPEED INSTALLATION,
 SAVING BOTH TIME AND MONEY.**

BENEFITS:

- One piece angles are fastened together in the corners. Only two sets of angles to handle per damper (rather than four separate angles per side).
- Angles are shipped with damper - no sorting or matching.
- Provided with pre-drilled fastening holes on 2" (51) centers to ensure correct angle/sleeve attachment.
- Factory fabricated by Nailor to suit the individual fire damper.
- Reduced cost when compared to conventional retaining angles.
- Dampers can ship directly to the job site complete with all necessary installation sheet metal hardware (saves on double handling at contractor's shop).
- Help ensure a correct installation as per U.L. approved installation instructions.

The majority of installing contractors view fire damper installation as a costly time consuming and troublesome procedure. Eight conventional angles must be custom fabricated for each damper either in a sheet metal shop or at the job site and sized to suit each individual damper. Invariably, they are mislaid or lost and must be matched to each factory supplied damper.

The Nailor "Quick-Set" solution solves the majority of problems. They are pre-formed to fit and ship with the individual damper for ultimate convenience. "Quick-Set" angles are supplied with correctly spaced pre-drilled screw-holes to ensure a quick, easy and accurate installation for all integral sleeve Nailor fire and combination fire/smoke dampers - no measuring required.

"Quick-Set" retaining angles provide the "complete" installation package. Simple, fast, convenient.

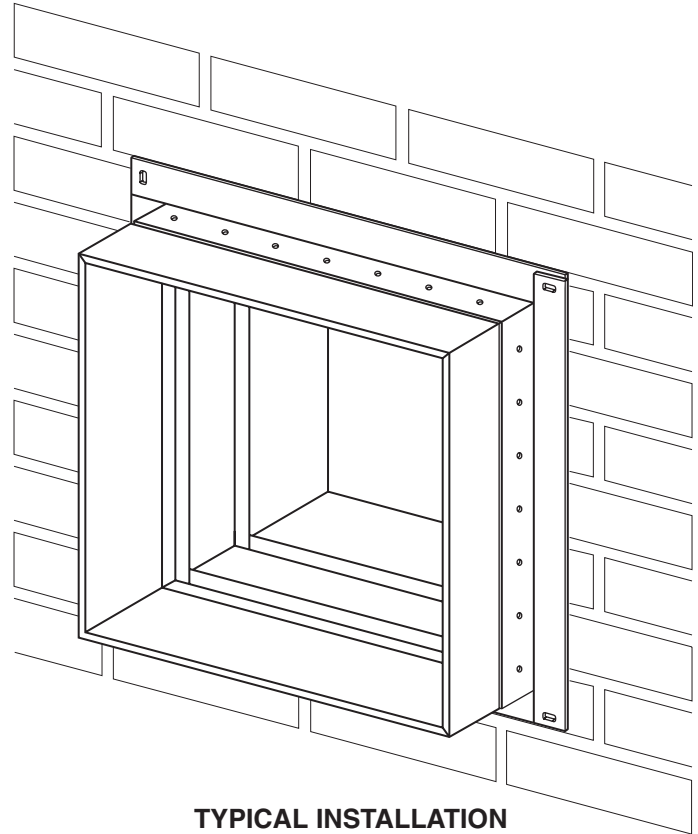

TYPICAL INSTALLATION

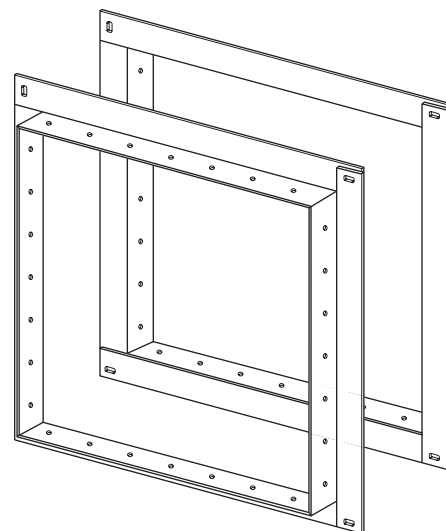

**TYPICAL PAIR OF PRE-ASSEMBLED
 'QUICK-SET' RETAINING ANGLES**



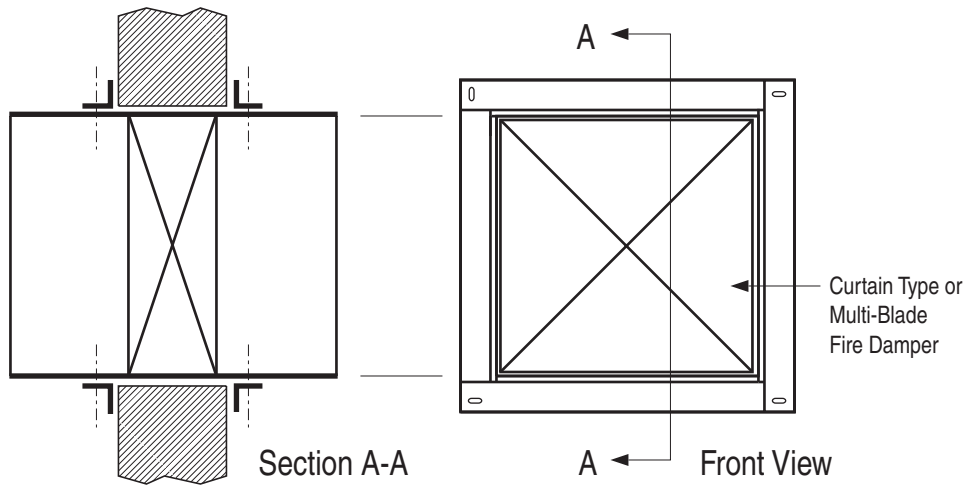

FIGURE 1. TYPICAL TWO SIDED INSTALLATION.

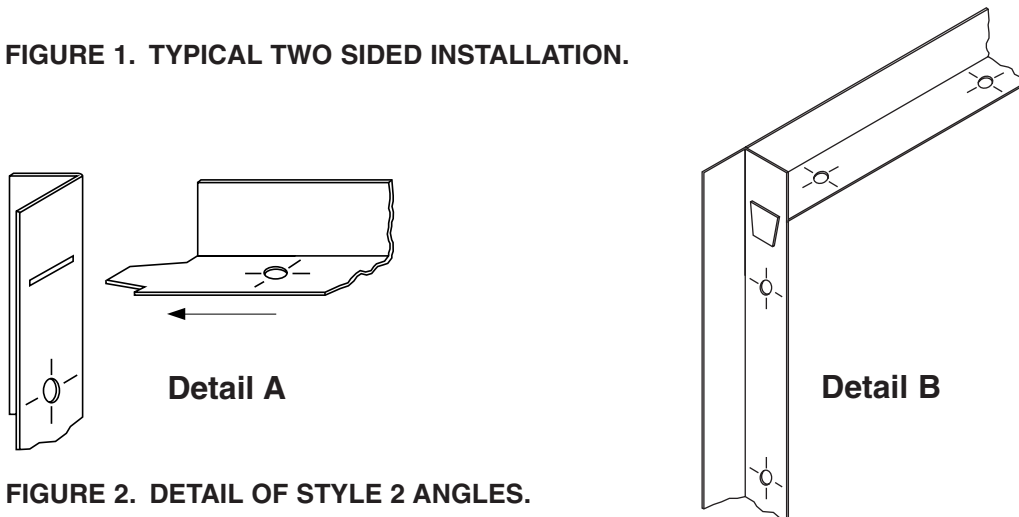

FIGURE 2. DETAIL OF STYLE 2 ANGLES.

APPLICATION:

The Nailor Quick-Set Retaining Angle System may be used in lieu of conventional retaining angles on all Nailor Fire and Combination Fire / Smoke Dampers.

Quick-Set angles are supplied in one of two styles, dependent upon fire resistance label, damper size and installation method.

Style 1: 1 1/2" x 1 1/2" x 20 ga. (38 x 38 x 1.0) Four sides are connected together with rivets in three corners.

Standard for the majority of applications with the following limitations:

- 1 1/2 hour label fire dampers
- Maximum Size: 36" x 36" (914 x 914)
- Two sided installation only

Style 2: 1 1/2" x 1 1/2" x 16 ga. (38 x 38 x 1.6) Slot and tab design. The retaining angle assembly for each side has four angles, each with a tab end and a slot end (Detail A). The tabs are to be inserted into the slots and knocked down either before or after fastening to the sleeve (Detail B).

- 1 1/2 or 3 hour label fire dampers
- Maximum Size: 90" x 48" (2286 x 1219) or 48" x 90" (1219 x 2286)
- Single side (1 1/2 hour only. Refer to Single Side Retaining Angles Supplementary Installation Instructions for size limitations) or two sided installation

Refer to the Following Installation Instructions:

Curtain Type Fire Dampers (D)0100 & (D)0500	FDINST
Curtain Type Fire Dampers 0200 & 0500 Thinline	FDTINST
Multi-Blade Fire Dampers 1200 & 1250	MBFDINST
Combination Fire/Smoke Dampers 1220	1220INST
Combination Fire/Smoke Dampers 1270	1270INST
Single Side Retaining Angles	FDSSRAINST



Dimensions are in inches (mm).



Houston, Texas
Tel: 281-590-1172
Fax: 281-590-3086

Las Vegas, Nevada
Tel: 702-648-5400
Fax: 702-638-0400

Toronto, Canada
Tel: 416-744-3300
Fax: 416-744-3360

Calgary, Canada
Tel: 403-279-8619
Fax: 403-279-5035

APPLICATION:

Fire dampers are UL/ULC Classified for their maximum size or maximum assembly size. Generic steel mullions can be used in static HVAC systems to separate vertically mounted 1 1/2 hour labeled galvanized steel fire dampers in vertical wall openings larger than maximum UL/ULC permitted multiple damper assembly size. Fire dampers must not exceed a maximum 120" (3048) height by unlimited width using vertical mullions every 120" (3048) max. Mullions are not intended to be part of the ductwork. (i.e. exposed to airflow).

Whenever the duct size exceeds the maximum damper width or height, the opening must be divided into two or more separate openings with a mullion installed between the damper sections. The mullion consists of a vertical and/or horizontal mullion and mullion caps. One cap for each end of the mullion.

The steel mullion is intended for use only in concrete block or poured walls with 7" (178) minimum and 12" (305) maximum thickness. Hollow concrete block walls are to be suitably filled with minimum 3500 psi concrete for proper securing of mullions.

Important Note: Steel mullions are for use in static systems only. UL/ULC does not acknowledge their use with dynamic fire dampers.

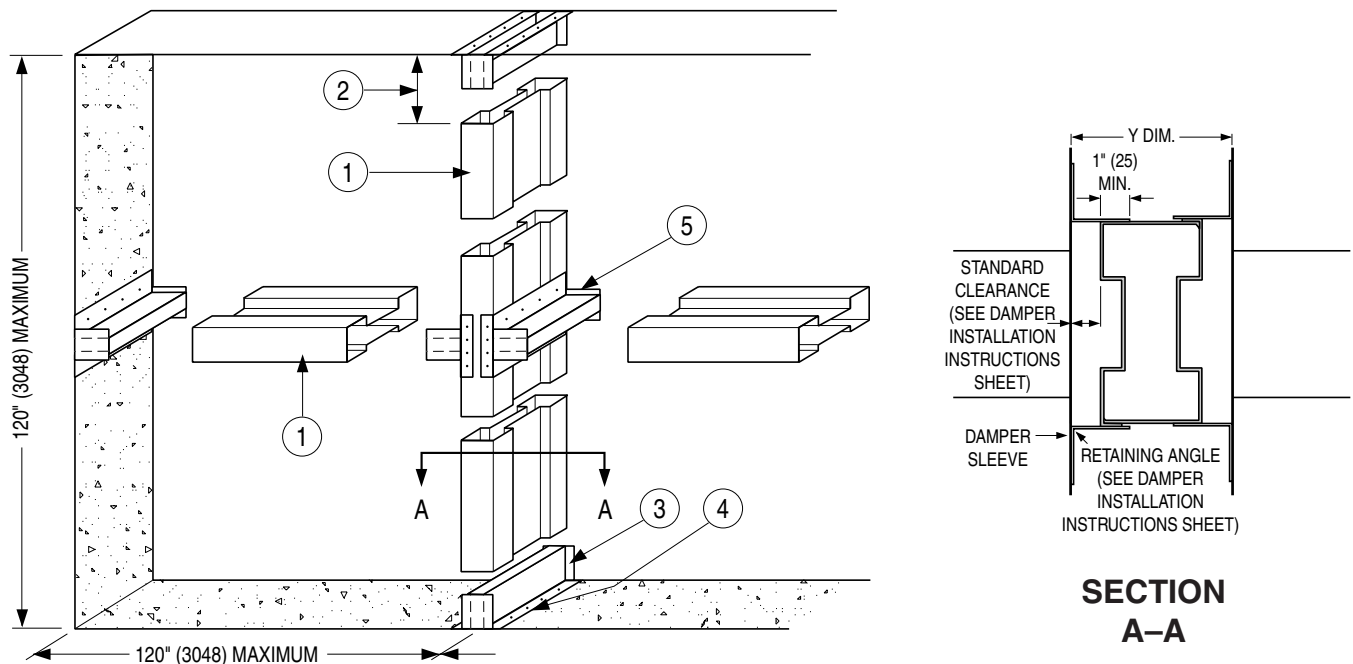

FABRICATION AND GENERAL INSTALLATION:

1. Fabricate mullions of 16 ga. (1.6) galvanized steel as shown in **Figure 1**. Two mullion pieces are joined with 3/16" (5) diameter steel pop rivets or 3/4" (19) long welds located 6" (152) maximum from each end and 12" (305) O.C. maximum.
2. The mullion should permit clearance between the mullion and top cap. Required clearance is 1/8" (3) per foot of wall opening height. Minimum permitted clearance is 1/4" (6). Maximum permitted clearance is 1 1/4" (32) (e.g. for an 8 ft. (2438) high opening the permitted clearance is 1/8" (3) x 8 = 1" (25) +).
3. Fabricate two caps for each mullion of 12 ga. (2.8) galvanized steel as shown in **Figure 2** for vertical and horizontal mullions. (Caps must permit mullion to overlap each cap by minimum 3" (76)). Cap height is calculated by adding 3" (76) to permitted mullion expansion clearance which is 1/8" (3) per foot of wall opening height. Insert mullion caps into mullion ends allowing mullion to float between the caps. Do not fasten mullion to caps in any way. Locate within opening to provide correct expansion clearance for dampers.
4. Drill holes in caps and concrete for anchoring steel mullion caps with 1/4" (6) – 20 x 5/16" (8) steel screws and 3/8" (10) diameter x 1" (25) concrete expansion anchors. The eight holes to secure the cap (**Figure 3**) are equally spaced, X ÷ 8 from both ends and 1/2" (13) inwards of each side.
5. Set horizontal mullion caps at vertical mullions as shown (**Figure 4**). If steel lintels are present, four 1" (25) welds (two per mullion cap leg) may be used to anchor each mullion cap.

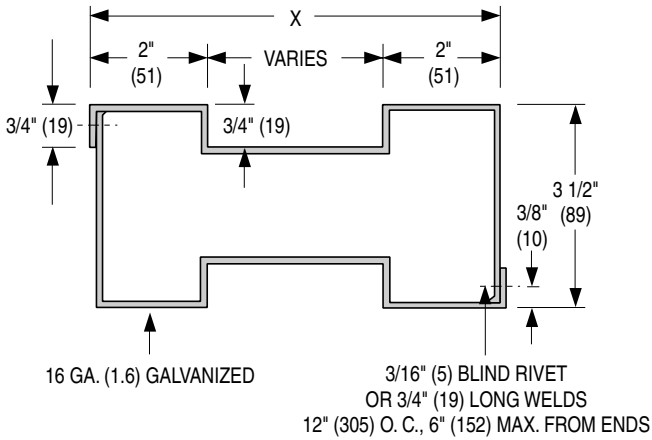

FIGURE 1
MULLION CROSS-SECTION

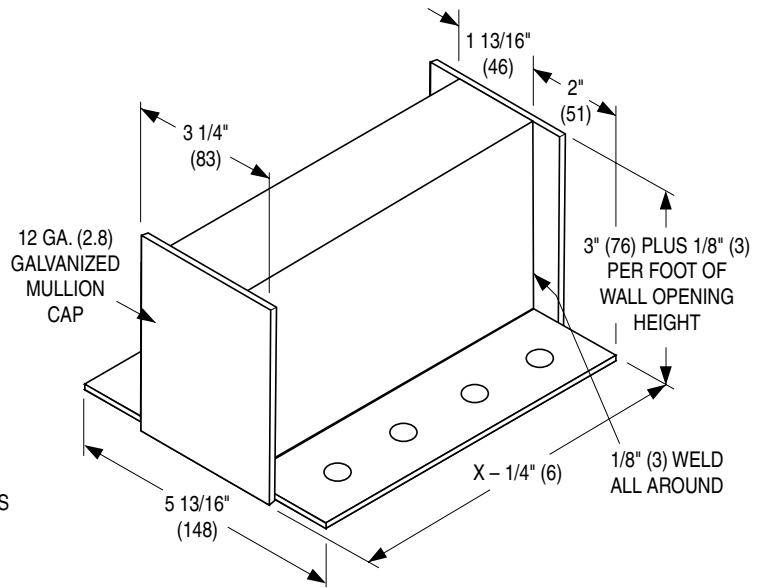

FIGURE 2

X = WALL THICKNESS

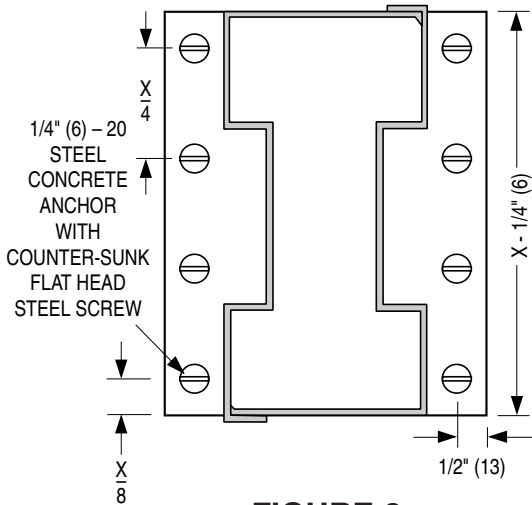

FIGURE 3

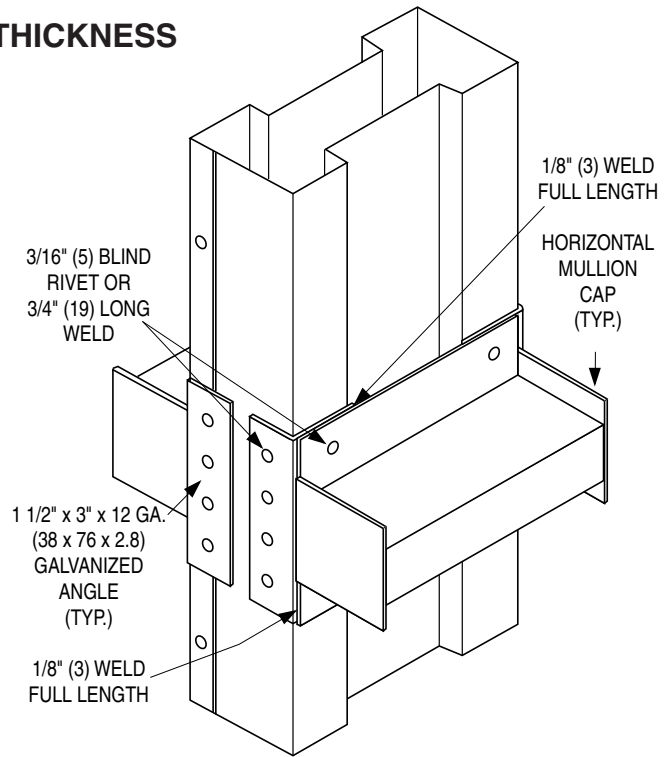

FIGURE 4



Refer to the UL or ULC Classification Marking on the Product

These instructions comply with Underwriters Laboratories Safety Standard 555.

Dimensions are in inches (mm).

Page 2 of 2



Houston, Texas
Tel: 281-590-1172
Fax: 281-590-3086

Las Vegas, Nevada
Tel: 702-648-5400
Fax: 702-638-0400

Toronto, Canada
Tel: 416-744-3300
Fax: 416-744-3360

Calgary, Canada
Tel: 403-279-8619
Fax: 403-279-5035

Detail 1A
Angle over
drywall.

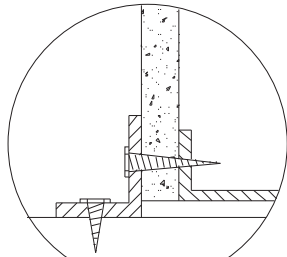
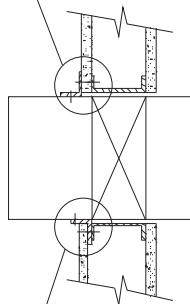

Figure 1
Metal Stud



Detail 1B
Angle under
drywall.

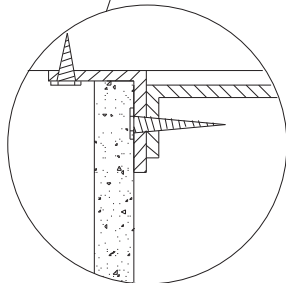

Figure 2
Wood Stud

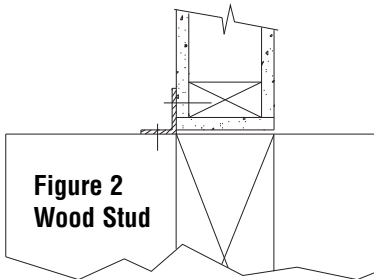
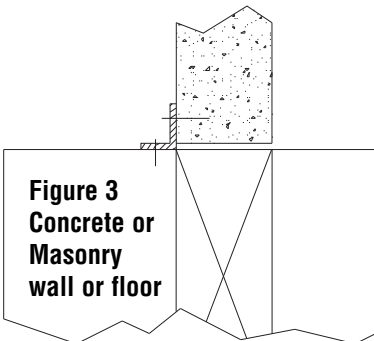

Figure 3
Concrete or
Masonry
wall or floor



NOTES:

1. For the maximum sizes listed below, all Nailor 1 1/2 hour labeled curtain, multi-blade and combination fire/smoke dampers may be installed using single-side retaining angles in lieu of the conventional two-sided retaining angle method. Retaining angles may be field fabricated or factory supplied and may be installed in metal/wood stud or masonry walls and concrete floors.
2. Install dampers in accordance with the appropriate damper installation instruction sheet in conjunction with this supplement. Replace conventional two-sided retaining angles with single-sided retaining angles as appropriate. Retaining angles may be installed on either side for vertical partition installations, but must be installed on the top side for a floor installation. Retaining angles must be attached to both the sleeve and the wall or floor.
3. Retaining angles required on all four sides unless installed on top of a concrete floor slab (See Note 6).
4. Single-sided retaining angles shall be a minimum of 1 1/2" x 1 1/2" x 16 ga. (38 x 38 x 1.61) steel for metal stud, masonry walls or concrete floors. For wood stud partitions, retaining angles shall be a minimum of 2" x 1 1/2" x 16 ga. (51 x 38 x 1.61) steel. For metal stud partitions only, the single-side retaining angle may be directly attached to the metal stud prior to the installation of the drywall. See Detail 1B.
5. Attach the 1 1/2" (38) leg of the retaining angles to the damper sleeve using 1/2" (13) long welds, 1/4" (6) diameter bolts and nuts, 3/16" (5) diameter steel rivets or #8 sheet metal screws, 6" (152) o.c.. Secure the retaining angles to the structural members of a vertical drywall wall using drywall screws. In the case of wood stud construction (see Figure 2), the screws should be a minimum of 2 1/2" (64) long, with minimum 1 1/4" (32) penetration into framing. In the case of masonry walls or concrete floors (see Figure 3), use 1/4" (6) masonry anchors 1 1/2" (38) minimum length, with minimum 1 1/4" (32) penetration into wall or floor. All fasteners to be on a maximum of 12" (305) o.c. with a minimum of two fasteners per side, top, and bottom.
6. In the case where the damper sits directly on a concrete floor slab, the bottom retaining angle is not required if the damper sleeve is fastened directly to the slab using 1/4" (6) masonry anchors 1 1/2" (38) minimum length, with minimum 1 1/4" (32) penetration into the floor. All fasteners to be on a maximum of 12" (305) o.c. with a minimum of 2 fasteners (See Figure 4).

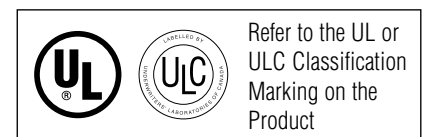
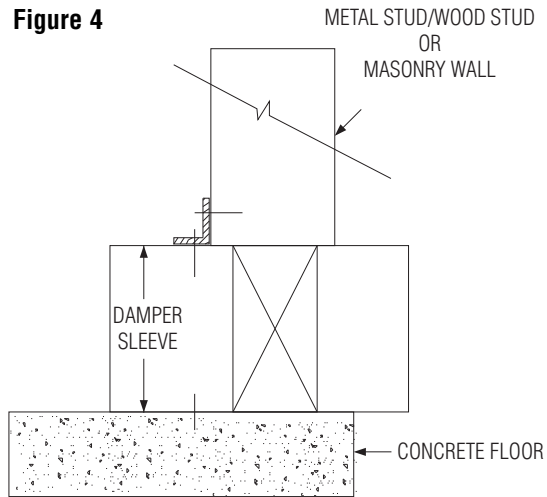

Figure 4



7. No firestop caulking is required on this product.

Underwriters' Laboratories file # R9492.
Also conforms to NFPA 90A and NFPA 92.
Maximum sizes: 96" W x 36" H (2438 x 914) or
36" W x 96" H (914 x 2438).

NOTES:

1. These details are based upon tests conducted by the Gypsum Association. Consult the local authority having jurisdiction for other acceptable framing methods.
2. Frame wall openings as shown in Figure 1 or 2.
3. Gypsum panels must be screwed to all stud and runner flanges, 12" (305) max. o.c. surrounding opening.
4. All fasteners to be per UL/ULC Classified wall design.
5. UL/ULC wood stud designs require gypsum wallboard filler pieces to be installed around entire opening, screwed 12" (305) o.c. to web of runners and studs, covering all wood stud surfaces.
 In UL metal stud designs, exposed steel surfaces need not be covered with gypsum wallboard. ULC metal stud construction however may still require filler pieces, check with the local authorities.
6. Refer to standard installation instructions sheet for additional details.

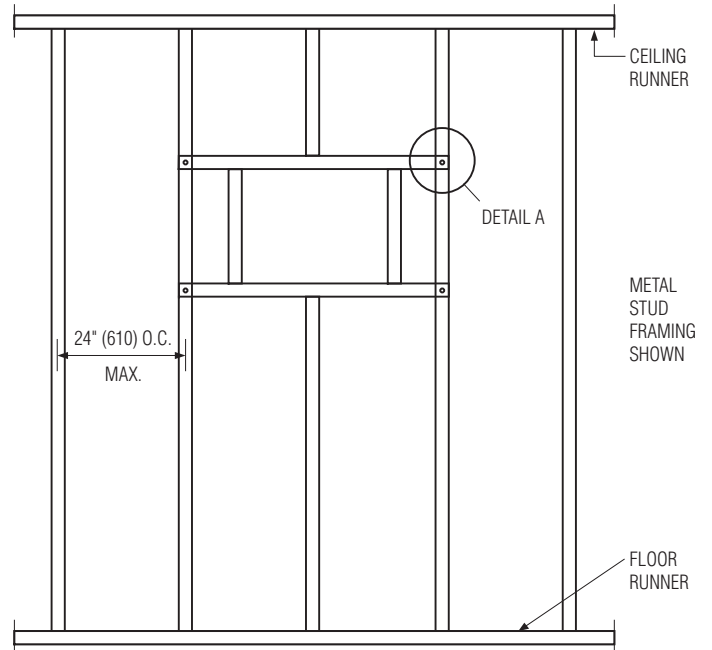

FIGURE 1. SINGLE VERTICAL STUD OPENING PREPARATION DETAILS.
 DAMPERS UP TO 36" x 36" (914 x 914).

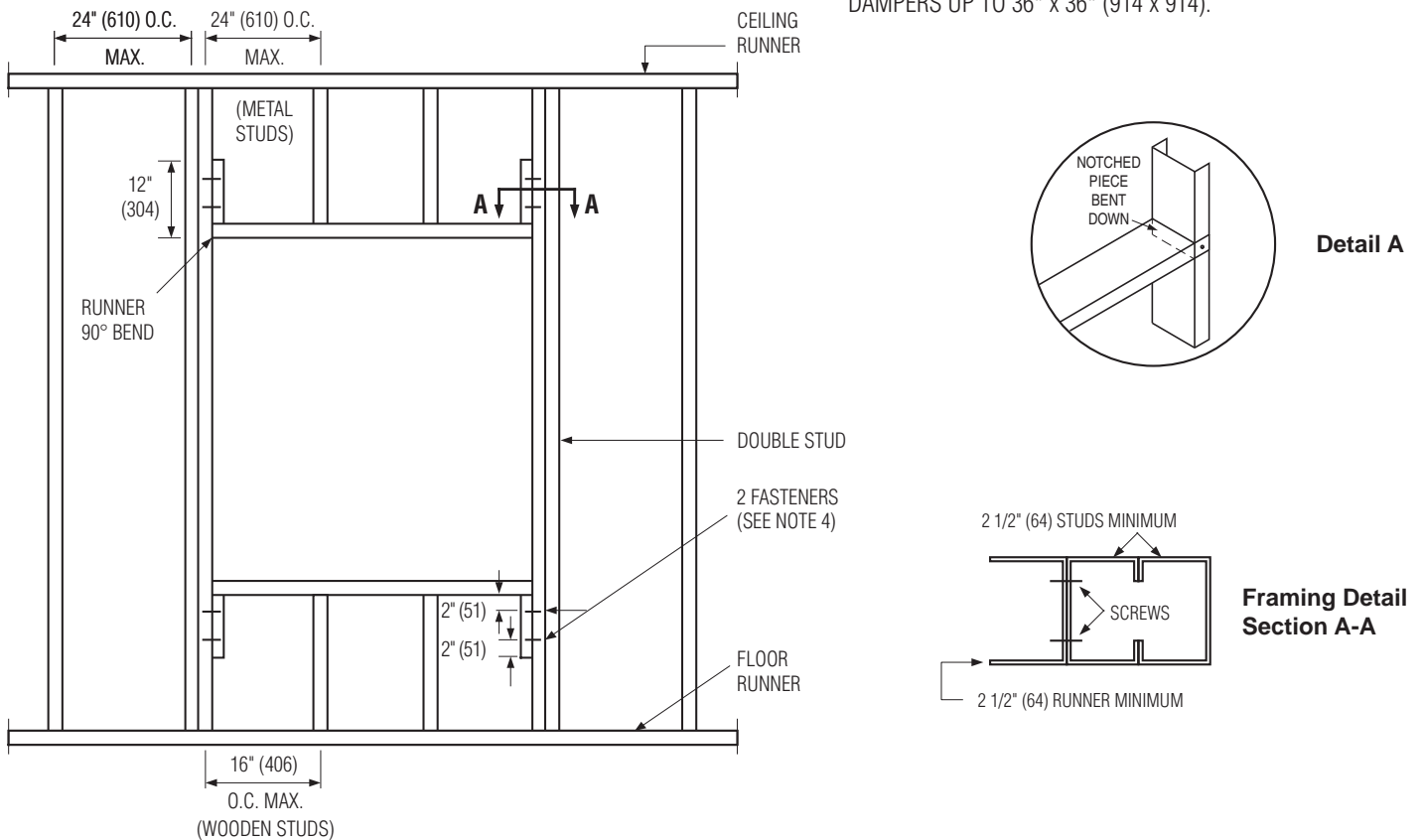
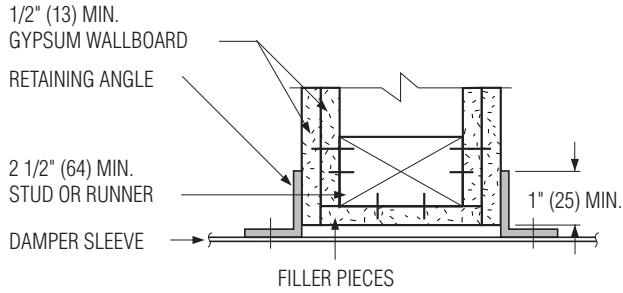

FIGURE 2. DOUBLE VERTICAL STUD OPENING PREPARATION DETAILS.
 DAMPERS OVER 36" x 36" (914 x 914).

TYPICAL STUD WALL DETAILS (See Notes on Page 1)

WOOD STUD DETAIL



2 Hour Partition Rating

METAL STUD DETAIL (UL DESIGN)

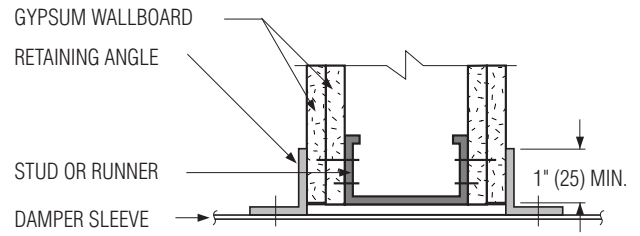

2 Hour Partition Rating

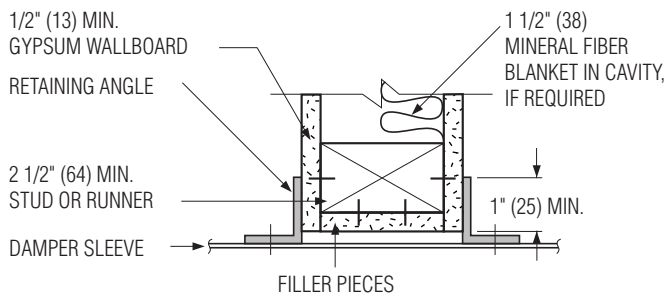

1 Hour Partition Rating

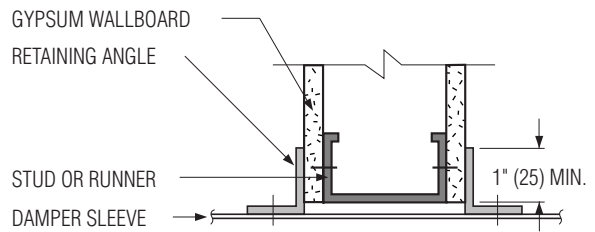

1 Hour Partition Rating

Dimensions are in inches (mm).

Page 2 of 2



Houston, Texas
Tel: 281-590-1172
Fax: 281-590-3086

Las Vegas, Nevada
Tel: 702-648-5400
Fax: 702-638-0400

Toronto, Canada
Tel: 416-744-3300
Fax: 416-744-3360

Calgary, Canada
Tel: 403-279-8619
Fax: 403-279-5035

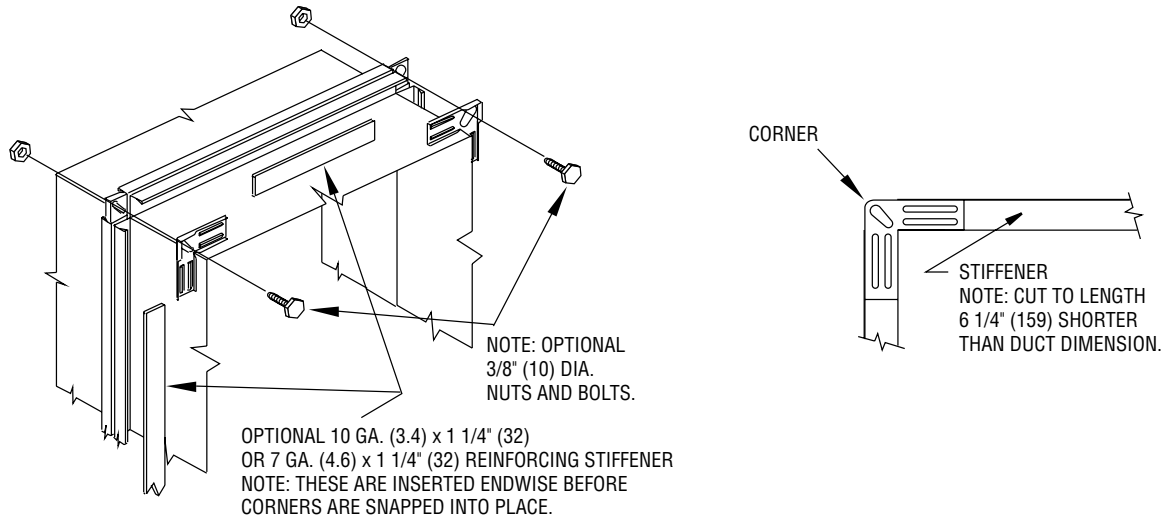

RECOMMENDED CLIP SPACING

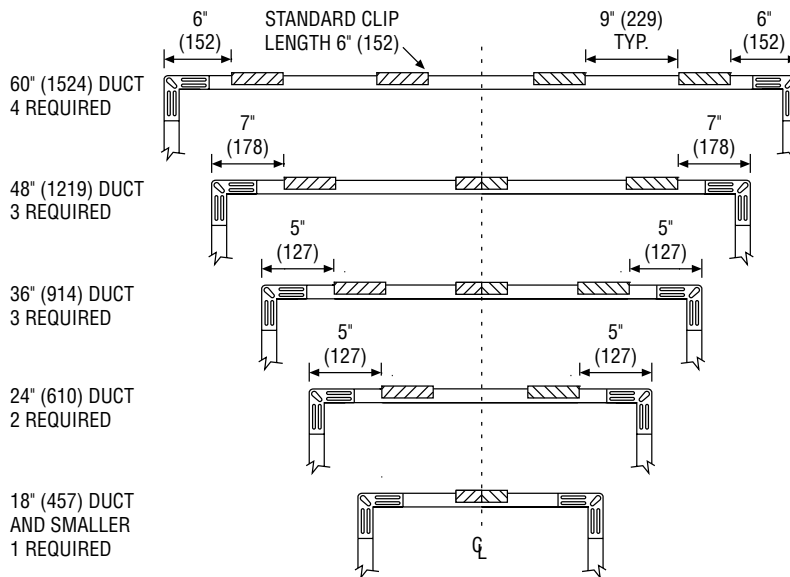

CLEAT DETAILS

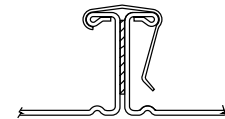

TDC CROSS SECTION

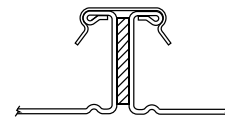

TDF CROSS SECTION

Damper Type	Max. Size W x H		No. Cleats Per Side
	(inches)	(mm)	
Curtain	18 x 18	457 x 457	1
	24 x 24	610 x 610	2
	48 x 48	1219 x 1219	3
	60 x 60	1524 x 1524	4
Multi-Blade	18 x 18	457 x 457	1
	24 x 24	610 x 610	2
	36 x 48	914 x 1219	3

APPLICATION:

TDC (by Lockformer) and TDF (by Engle) are approved as breakaway connections for joining the fire damper sleeve and the duct. The slip joints shown in standard installation instructions for curtain type fire dampers, multi-blade fire dampers and combination fire/smoke dampers may be replaced by one of these systems.

INSTALLATION:

TDC and TDF roll-formed 4-bolt flanged connections assembled per the manufacturers instructions using gaskets, metal cleats 6" (152) long with spacing as shown and four 3/8" (9.5) metal nuts and bolts. See also the TDC or TDF addendum to the SMACNA Duct Construction Standards.



Houston, Texas
Tel: 281-590-1172
Fax: 281-590-3086

Ft. Lauderdale, Florida
Tel: 954-351-2444
Fax: 954-351-2440

Toronto, Canada
Tel: 416-744-3300
Fax: 416-744-3360

Calgary, Canada
Tel: 403-279-8619
Fax: 403-279-5035

These instructions are for installing vertical mount fire and combination fire smoke dampers in a fire resistant ventilation duct (UL Ventilation duct Assembly HNLN.V-5).



NOTES:

1. The damper sleeve must slip inside the fire resistant duct spool. Damper sleeve assembly will be 1/4" (6), 1/2" (13) maximum, smaller than duct spool size.
2. Damper is to be supplied with factory mounted sleeve. Sleeve gauge will be minimum of 16 ga. (1.5) for dampers up to 36" wide x 24" high (914 x 610) and 14 ga. (2) for dampers exceeding 36" wide x 24" high (914 x 610).
3. Mounting angles need to be the following sizes:
 - 1 1/2" x 1 1/2" x 1/4" up to 24" (38 x 38 x 6 up to 610)
 - 2" x 2" x 1/4" over 24" up to 32" (51 x 51 x 6 over 610 up to 813)
 - 2 1/2" x 2 1/2" x 1/4" over 32" up to 40" (64 x 64 x 6 over 813 up to 1016)
 - 3" x 3" x 1/4" above 40" (76 x 76 x 6 above 1016)
4. Mounting angle fasteners:
 - #10 bolts or screws
 - 3/16" (4.7) steel rivets
 - 1/2" (13) long welds
5. Mounting Angle Fasteners Spacing:
 - Mounting angles to dampers, space fasteners on 6" (152) on center.
 - Mounting angle to spool flange, space fasteners on 12" (305) on center.
 - Minimum 2 fasteners per side
6. Hanger rods:
 - 3/8" (10) threaded rod anchored to the floor above and attached to the mounting angles through hole in the angles and secured with hex nut and washer (items 5 & 6). Anchor to masonry per assembly No. V-5.
7. Duct to Damper Sleeve Connection:
 - See the fire damper or the combination fire smoke installation instructions for breakaway, flanged, or non-breakaway connections.

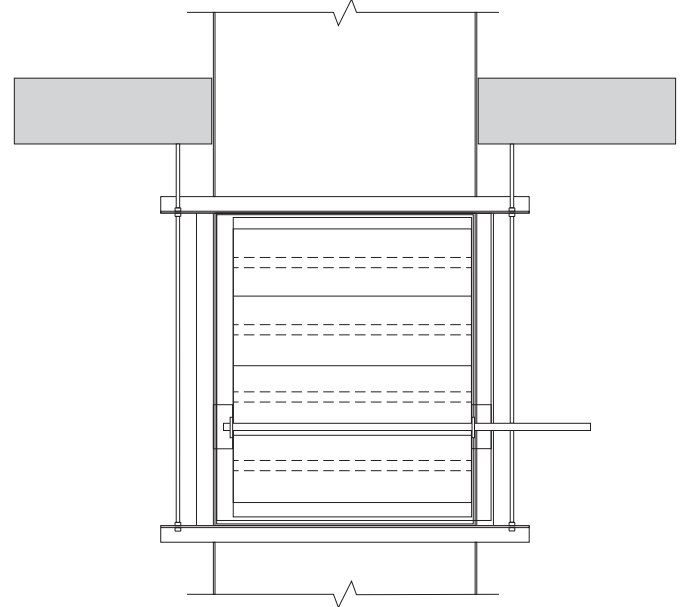

END VIEW

Item	Description
1	Fire Resistant Ventilation Duct (UL HNLN Assembly No. V-5)
2	Fire Damper or Combination Fire/Smoke Damper
3	Hanger rods in accordance with assembly No. V-5
4	Mounting angles (see instruction #3)
5	3/8" (10) hex nuts
6	3/8" (10) flat washer
7	Mounting angle fasteners (see instruction #4)

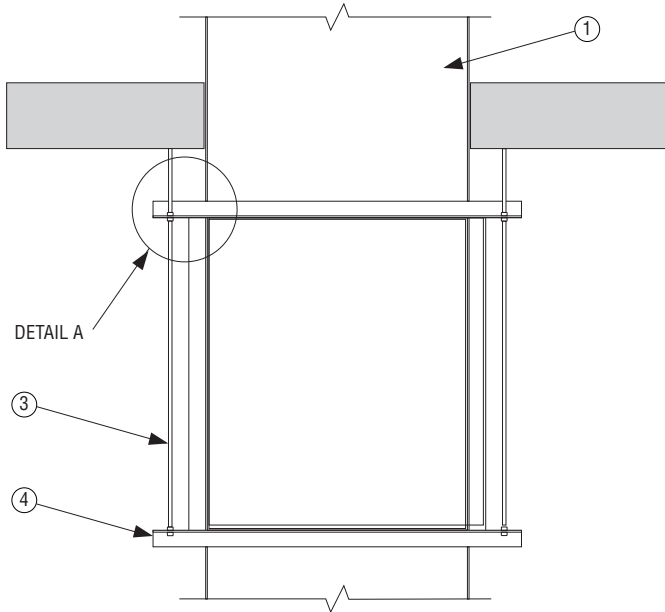

END VIEW

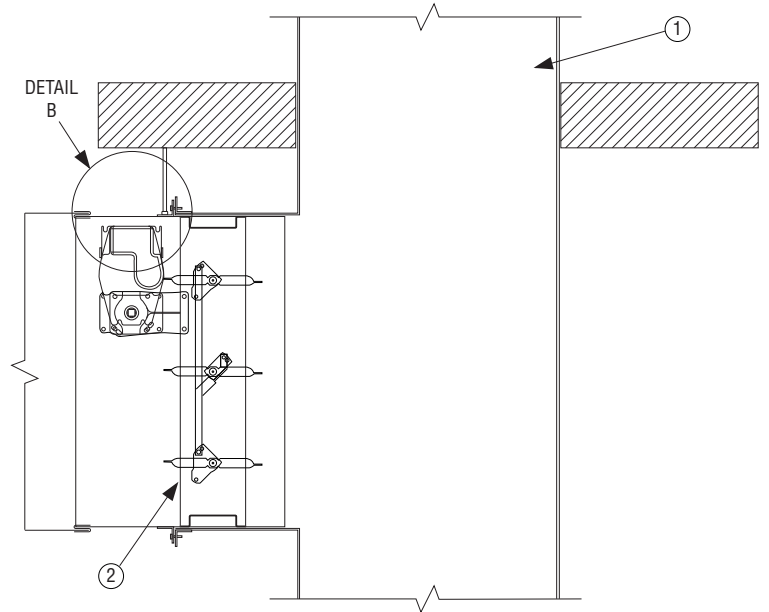

SIDE VIEW

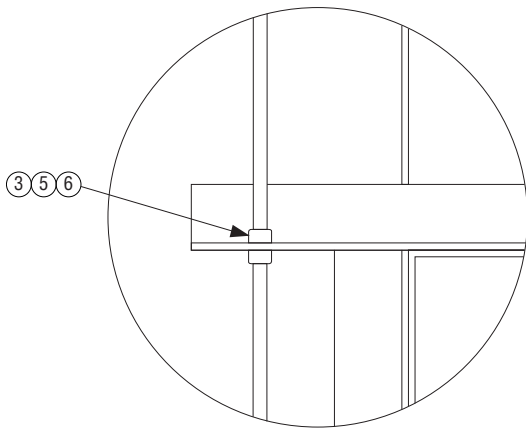

DETAIL A

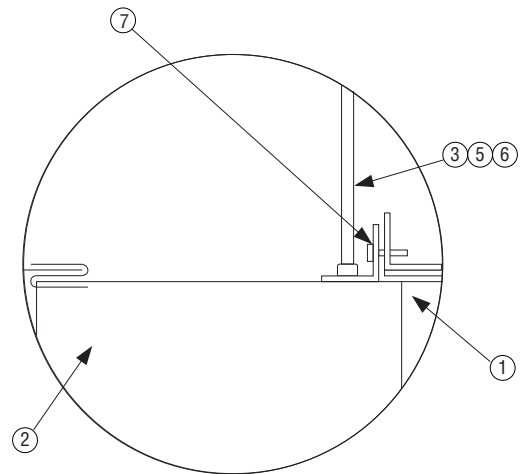

DETAIL B

Dimensions are in inches (mm).



Houston, Texas
Tel: 281-590-1172
Fax: 281-590-3086

Las Vegas, Nevada
Tel: 702-648-5400
Fax: 702-638-0400

Toronto, Canada
Tel: 416-744-3300
Fax: 416-744-3360

Calgary, Canada
Tel: 403-279-8619
Fax: 403-279-5035

Trimming of factory-supplied sleeves may be necessary to accommodate field conditions or applications. Other damper components such as actuators and fuse links should not be altered.

NOTES:

- 1. Sleeve Length on Non-actuator side:** 6" (152) maximum sleeve length beyond fire-rated barrier on non-actuator side.
- 2. Sleeve Length on Actuator side:** 16" (406) maximum sleeve length beyond fire-rated barrier on actuator side.

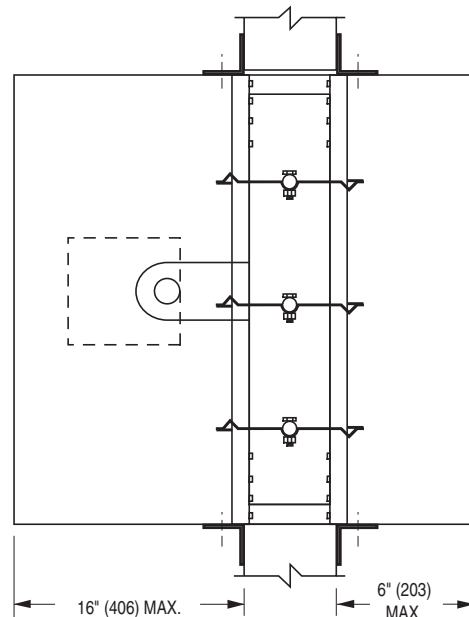
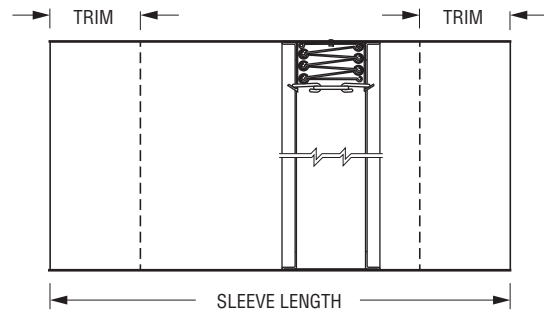
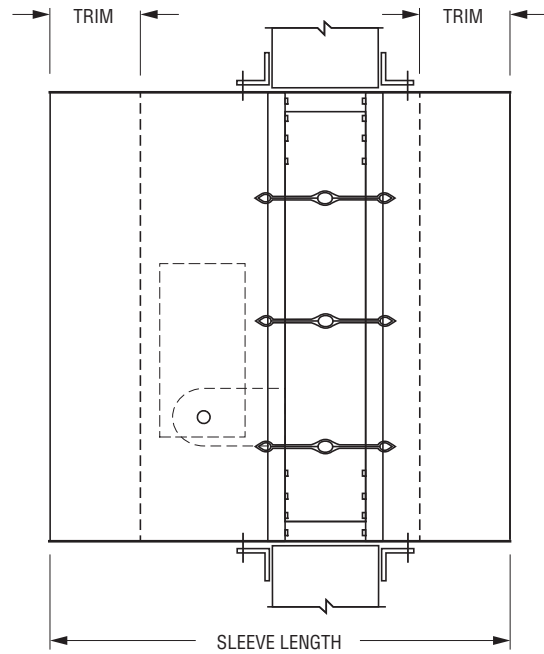

Dimensions are in inches (mm).



Houston, Texas
Tel: 281-590-1172
Fax: 281-590-3086

Las Vegas, Nevada
Tel: 702-648-5400
Fax: 702-638-0400

Toronto, Canada
Tel: 416-744-3300
Fax: 416-744-3360

Calgary, Canada
Tel: 403-279-8619
Fax: 403-279-5035