

The 1010/20 Series are Nailor's most widely used low leakage control dampers and are the standard choice for use in the majority of low to medium velocity and pressure commercial HVAC systems. They are low cost, high quality dampers that meet or exceed the majority of standard specification requirements. They meet the frequently specified leakage criteria of less than 10 cfm per sq. ft. @ 4" w.g. The design features include a sturdy hat channel frame with die-formed corner gussets for reinforcement and structural strength, a vee groove blade design that maximizes strength and zero maintenance concealed linkage (out of the air stream) for reduced pressure drop and air turbulence.

**RATINGS:**

**VELOCITY:** Up to 3000 fpm (15.2 m/s)  
**PRESSURE:** Up to 5" wg. (1.2 kPa)  
**LEAKAGE:** 4 cfm/sq. ft. @ 1" wg (20 l/s/m<sup>2</sup> @ 0.25 kPa)  
 8 cfm/sq. ft. @ 4" wg (41 l/s/m<sup>2</sup> @ 1.0 kPa)

**TEMPERATURE RANGE:** -50°F to +180°F (-46°C to +82°C).

**STANDARD CONSTRUCTION:**

**FRAME:** 5" x 7/8" x 16 ga. (127 x 22 x 1.6) galvanized steel hat channel with die-formed corner gussets. Low profile (flat top and bottom) on dampers 10" (254) high and under.

**BLADES:** 6" (152) wide on 5 1/2" (140) centers. 16 ga. (1.6) galv. steel vee groove design. Parallel or opposed action.

**LINKAGE:** Concealed type totally enclosed within the frame and out of the airstream. Plated steel.

**BEARINGS:** 1/2" (13) dia. Celcon<sup>®</sup>.

**AXLES:** 1/2" (13) dia. plated steel double bolted to blades.

**DRIVE SHAFT:** 6" (152) long x 1/2" (13) dia. rigid drive shaft on all single section dampers. A 1/2" (13) or 1" (25) dia. factory installed jackshaft is standard on all multiple section dampers. See multi-section detail 1000 MSI.

**BLADE SEALS:** Dual durometer bulb type extruded PVC.

**JAMB SEALS:** Compression type cambered metal.

**Sizes (Duct W x H):**

Minimum		Maximum	
Single Section		Single Section	Multiple Section
Single Blade 6" x 4" (152 x 102)	Two Blades (parallel or opposed) 6" x 10" (152 x 254)	48" x 72" (1219 x 1829)	Unlimited

**OPTIONS:**

- BO** Oilite bearings
- 304** Type 304 Stainless Steel construction
- SMP** Actuator side mounting plate
- DLO** Lock-on drive shaft
- Other \_\_\_\_\_

Nailor offers a wide selection of electric actuators for factory or field installation.

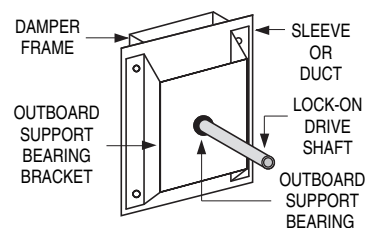
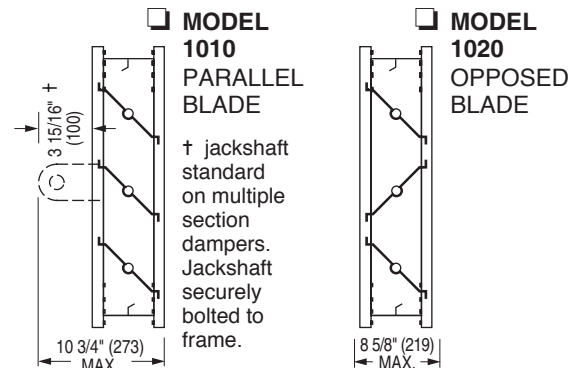
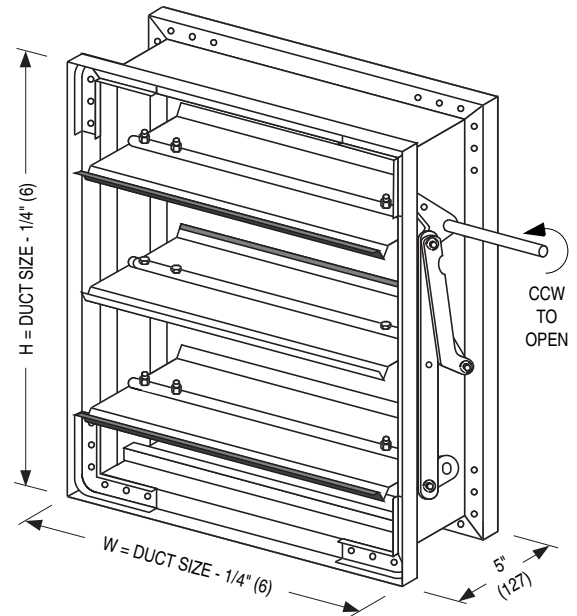

Optional lock-on drive shaft support bracket detail.

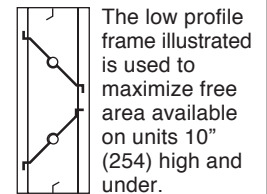
**SCHEDULE TYPE:**
**PROJECT:**
**ENGINEER:**
**CONTRACTOR:**

Page 1 of 2  
 Dimensions are in inches (mm).

DATE	A SERIES	SUPERSEDES	DRAWING NO.
5 - 15 - 26	1000	4 - 9 - 26	1000-1

**PERFORMANCE DATA:**  
**MODELS: 1010 AND 1020**

**FRAME OPTIONS:**

**PRESSURE DROP (damper fully open):**

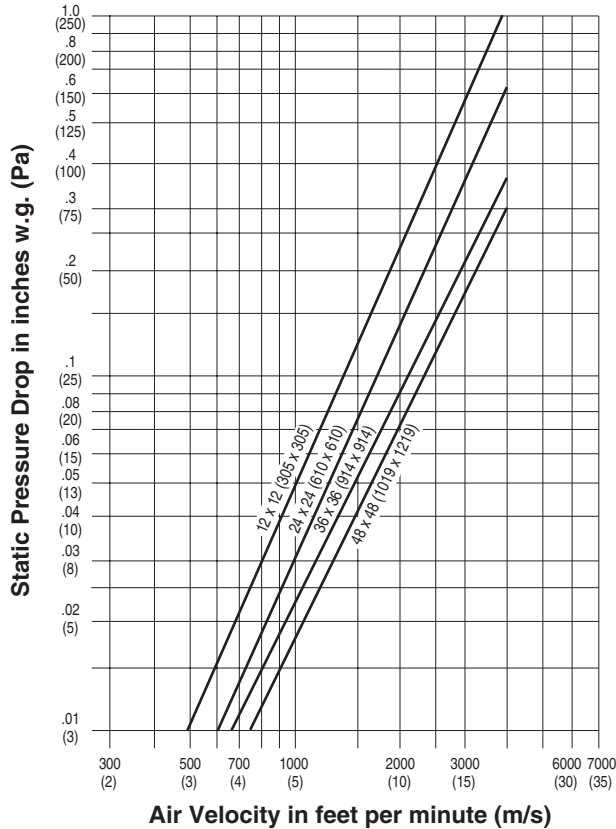

- FF** Flanged Front     **FR** Flanged Rear     **FD** Double Flange

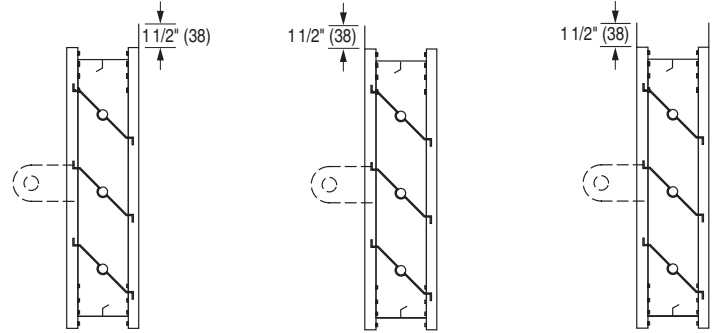

**DYNAMIC LIMITATIONS/LEAKAGE**

Damper Width	Maximum System Pressure	Maximum System Velocity	Leakage *	
			% of Max. Flow	Cfm/ Sq. Ft.
48" (1219)	2.5" w.g.	3000 fpm	0.18	3.5
36" (914)	3.0" w.g.	3000 fpm	0.2	4.0
24" (610)	4.0" w.g.	3000 fpm	0.23	4.5
12" (305)	5.0" w.g.	3000 fpm	0.33	6.6

\* Leakage information is based upon a pressure differential of 1" w.g. tested per AMCA standard 500-D, Fig. 5.5.

<b>SCHEDULE TYPE:</b>		Page 2 of 2			
<b>PROJECT:</b>		Dimensions are in inches (mm).			
<b>ENGINEER:</b>	<b>DATE</b>	<b>A SERIES</b>	<b>SUPERSEDES</b>	<b>DRAWING NO.</b>	
<b>CONTRACTOR:</b>	5 - 15 - 26	1000	4 - 9 - 26	1000-1	

The 1010/20 Series are Nailor's most widely used low leakage control dampers and are the standard choice for use in the majority of low to medium velocity and pressure commercial HVAC systems. They are low cost, high quality dampers that meet or exceed the majority of standard specification requirements. They meet the frequently specified leakage criteria of less than 10 cfm per sq. ft. @ 4" w.g. The design features include a sturdy hat channel frame with die-formed corner gussets for reinforcement and structural strength, a vee groove blade design that maximizes strength and zero maintenance concealed linkage (out of the air stream) for reduced pressure drop and air turbulence.

**RATINGS:**

**VELOCITY:** Up to 3000 fpm (15.2 m/s)  
**PRESSURE:** Up to 5" wg. (1.2 kPa)  
**LEAKAGE:** 4 cfm/sq. ft. @ 1" wg. (20 l/s/m<sup>2</sup> @ 0.25 kPa)  
 8 cfm/sq. ft. @ 4" wg. (41 l/s/m<sup>2</sup> @ 1.0 kPa)

**TEMPERATURE RANGE:** -50°F to +180°F (-46°C to +82°C).

**STANDARD CONSTRUCTION:**

**FRAME:** 5" x 7/8" x 16 ga. (127 x 22 x 1.6) galvanized steel hat channel with die-formed corner gussets. Low profile (flat top and bottom) on dampers 10" (254) high and under.

**BLADES:** 6" (152) wide on 5 1/2" (140) centers. 16 ga. (1.6) galv. steel vee groove design. Parallel or opposed action.

**LINKAGE:** Concealed type totally enclosed within the frame and out of the airstream. Plated steel.

**BEARINGS:** 1/2" (13) dia. Celcon<sup>®</sup>.

**AXLES:** 1/2" (13) dia. plated steel double bolted to blades.

**DRIVE SHAFT:** 6" (152) long x 1/2" (13) lock-on drive shaft on all single section dampers. A 1/2" (13) or 1" (25) dia. factory installed jackshaft is standard on all multiple section dampers. See multi-section detail 1000 MSI.

**BLADE SEALS:** Dual durometer bulb type extruded PVC.

**JAMB SEALS:** Compression type cambered metal.

**Sizes (Duct W x H):**

Minimum		Maximum	
Single Section		Single Section	Multiple Section
Single Blade 6" x 4" (152 x 102)	Two Blades (parallel or opposed) 6" x 10" (152 x 254)	48" x 72" (1219 x 1829)	Unlimited

**OPTIONS:**

- BO** Oilite bearings
- 304** Type 304 Stainless Steel construction
- SMP** Actuator side mounting plate
- BSP** Polyurethane foam blade seals
- JSS** Stainless steel jamb seals
- Other** \_\_\_\_\_

Nailor offers a wide selection of electric actuators for factory or field installation.

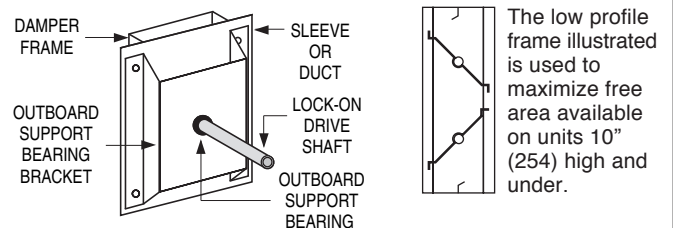
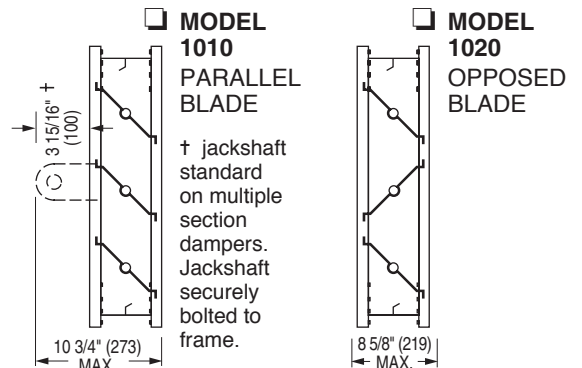
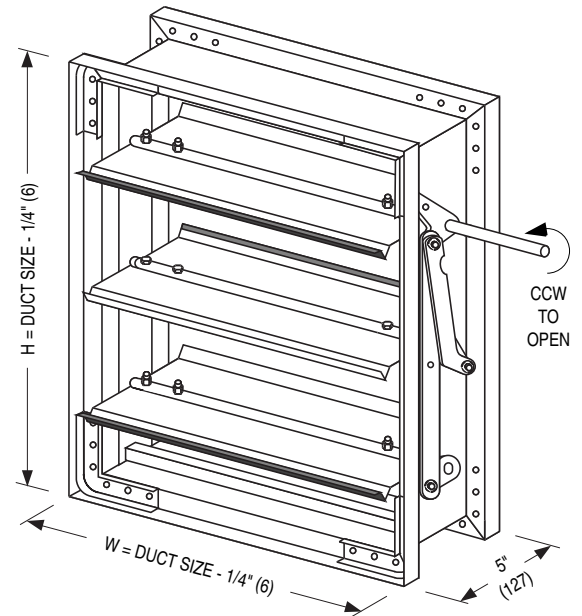

Optional lock-on drive shaft support bracket detail.

<b>SCHEDULE TYPE:</b>	Page 1 of 2			
<b>PROJECT:</b>	Dimensions are in inches (mm).			
<b>ENGINEER:</b>	<b>DATE</b>	<b>C SERIES</b>	<b>SUPERSEDES</b>	<b>DRAWING NO.</b>
<b>CONTRACTOR:</b>	5 - 15 - 26	1000	4 - 14 - 26	1000-1

**PERFORMANCE DATA:**  
**MODELS: 1010 AND 1020**

**FRAME OPTIONS:**

**PRESSURE DROP (damper fully open):**

- FF** Flanged Front     **FR** Flanged Rear     **FD** Double Flange

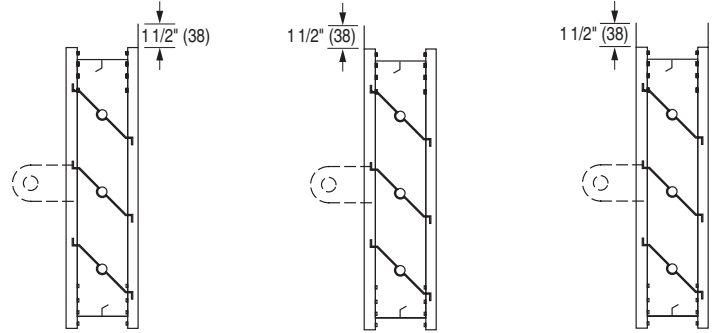
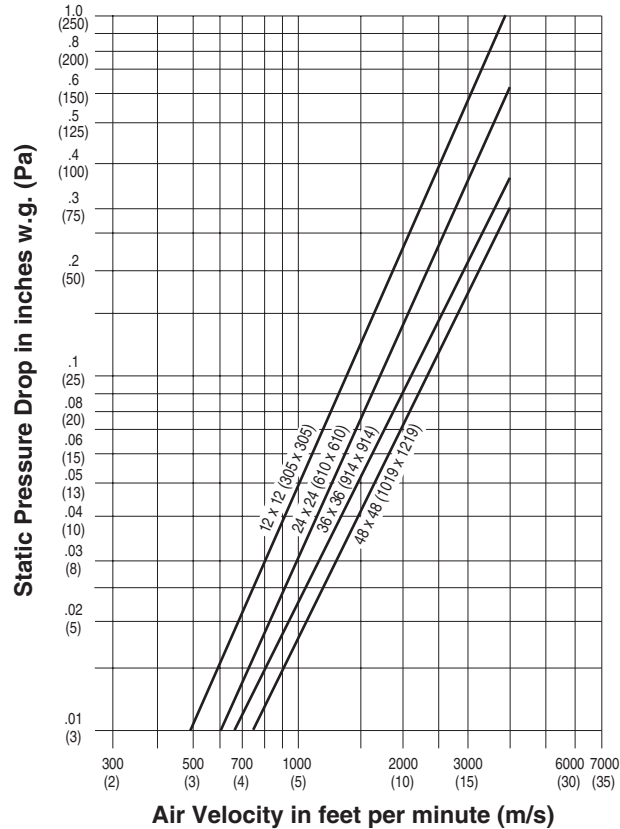

Tested per AMCA standard 500-D, Fig. 5.3.

**DYNAMIC LIMITATIONS/LEAKAGE**

Damper Width	Maximum System Pressure	Maximum System Velocity	Leakage *	
			% of Max. Flow	Cfm/Sq. Ft.
48" (1219)	2.5" w.g.	3000 fpm	0.18	3.5
36" (914)	3.0" w.g.	3000 fpm	0.2	4.0
24" (610)	4.0" w.g.	3000 fpm	0.23	4.5
12" (305)	5.0" w.g.	3000 fpm	0.33	6.6

\* Leakage information is based upon a pressure differential of 1" w.g. tested per AMCA standard 500-D, Fig. 5.5.

<b>SCHEDULE TYPE:</b>	Page 2 of 2			
<b>PROJECT:</b>	Dimensions are in inches (mm).			
<b>ENGINEER:</b>	<b>DATE</b>	<b>C SERIES</b>	<b>SUPERSEDES</b>	<b>DRAWING NO.</b>
<b>CONTRACTOR:</b>	5 - 15 - 26	1000	4 - 14 - 26	1000-1



**LOW LEAKAGE CONTROL DAMPER**  
**STEEL • STANDARD PERFORMANCE**  
**MODELS: 1010 & 1020 WITH 304 STAINLESS STEEL**  
**CONSTRUCTION OPTION**

Nailor Models 1010/1020 with optional 304 Stainless Steel construction provide an enduring solution for corrosive environment commercial and industrial HVAC and process applications. The proven vee groove blade design and sturdy hat channel mitered frame with reinforcing corner gussets afford solid performance that will withstand many normally harsh atmospheric and process elements. These dampers are engineered to meet the requirements of the International Energy Conservation Code (IECC), making them ideal for applications where energy conservation and thermal performance are critical.

**RATINGS:**

- Velocity:** Up to 3000 fpm (15.2 m/s)
- Pressure:** Up to 5" wg. (1.2 kPa)
- Leakage:** 4 cfm/sq. ft. @ 1" wg (20 l/s/m<sup>2</sup> @ 0.25 kPa)  
8 cfm/sq. ft. @ 4" wg (41 l/s/m<sup>2</sup> @ 1.0 kPa)

**Temperature**

- Range:** -50°F to +180°F (-46°C to +82°C).

**STANDARD CONSTRUCTION:**

- Frame:** 5" x 7/8" x 16 ga. (127 x 22 x 1.6) Type 304 stainless steel hat channel with stainless steel corner gussets. Frame and corner gussets are welded for rigidity. Low profile (flat top and bottom) on dampers 10" (254) high and under.
- Blades:** 6" (152) wide on 5 1/2" (140) centers. 16 ga. (1.6) Type 304 stainless steel vee groove design. Parallel or opposed action.
- Linkage:** Concealed type totally enclosed within the frame and out of the airstream. Type 304 stainless steel.
- Bearings:** 1/2" (13) dia. Celcon®.
- Axles:** 1/2" (13) dia. plated steel double bolted to blades.
- Drive Shaft:** 6" (152) long x 1/2" (13) dia. stainless steel rigid drive shaft on all single section dampers. A 1/2" (13) or 1" (25) dia. factory installed jackshaft is standard on all multiple section dampers. See multi-section detail 1000 MSI.
- Blade Seals:** Dual durometer bulb type extruded PVC.
- Jamb Seals:** Compression type cambered stainless steel.

**Sizes (Duct W x H):**

Minimum		Maximum	
Single Section		Single Section	Multiple Section
Single Blade 6" x 4" (152 x 102)	Two Blades (parallel or opposed) 6" x 10" (152 x 254)	48" x 72" (1219 x 1829)	Unlimited

**OPTIONS:**

- AMP Actuator mounting side plate
- DLO Lock-on drive shaft
- Other \_\_\_\_\_

Nailor offers a wide selection of pneumatic and electric actuators for factory or field installation.

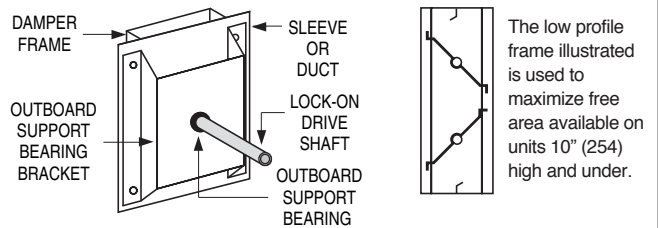
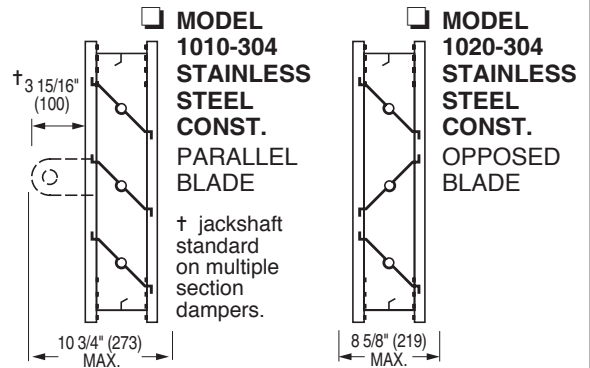
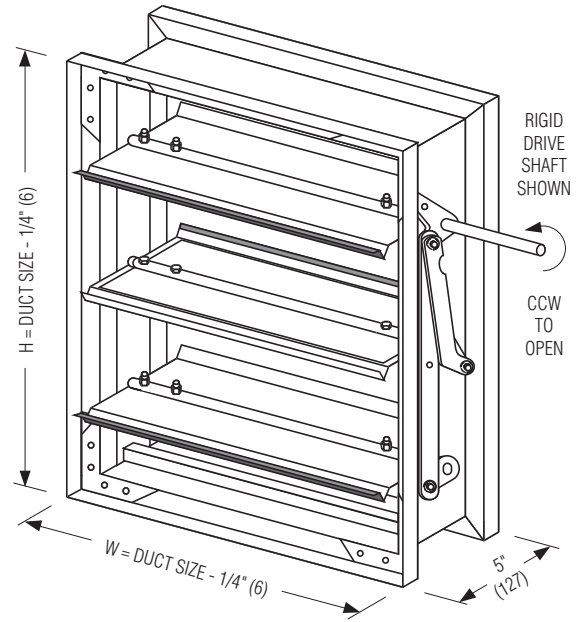

Optional lock-on drive shaft support bracket detail.

<b>SCHEDULE TYPE:</b>	Page 1 of 2			
<b>PROJECT:</b>	Dimensions are in inches (mm).			
<b>ENGINEER:</b>	<b>DATE</b>	<b>A SERIES</b>	<b>SUPERSEDES</b>	<b>DRAWING NO.</b>
<b>CONTRACTOR:</b>	5- 15 - 26	1000	4 - 14 - 26	1000-1C



**LOW LEAKAGE CONTROL DAMPER**  
**STEEL • STANDARD PERFORMANCE**  
**MODELS: 1010 & 1020 WITH 304 STAINLESS STEEL**  
**CONSTRUCTION OPTION • PERFORMANCE DATA**

**PERFORMANCE DATA:**  
**MODELS: 1010 AND 1020**

**FRAME OPTIONS:**

- FF** Flanged Front     **FR** Flanged Rear     **FD** Double Flange

**PRESSURE DROP (damper fully open):**

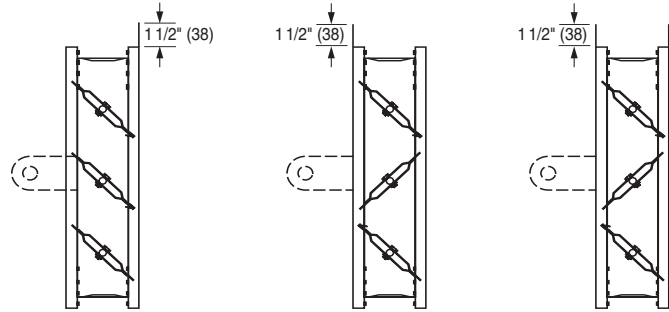
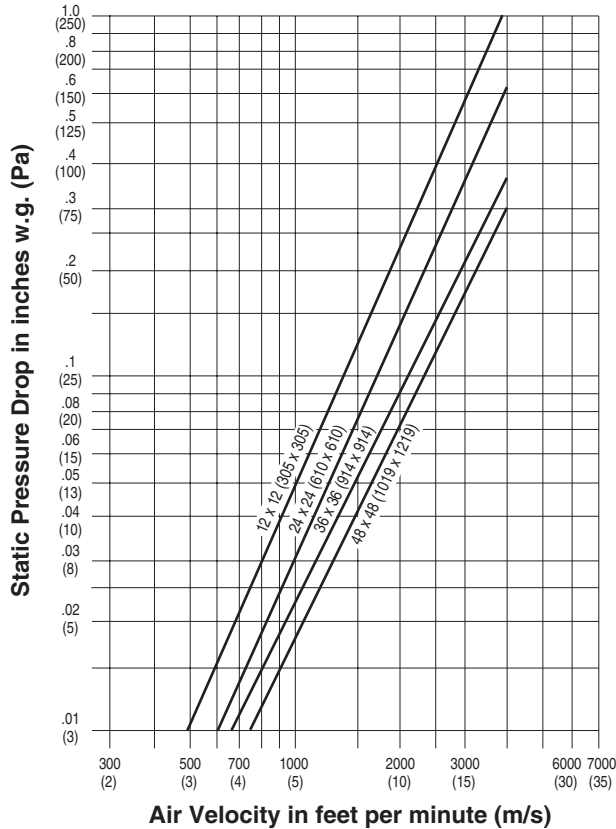

**DYNAMIC LIMITATIONS/LEAKAGE**

Damper Width	Maximum System Pressure	Maximum System Velocity	Leakage *	
			% of Max. Flow	Cfm/ Sq. Ft.
48" (1219)	2.5" w.g.	3000 fpm	0.18	3.5
36" (914)	3.0" w.g.	3000 fpm	0.2	4.0
24" (610)	4.0" w.g.	3000 fpm	0.23	4.5

\* Leakage information is based upon a pressure differential of 1" w.g. tested per AMCA standard 500-D, Fig. 5.5.

<b>SCHEDULE TYPE:</b>		Page 2 of 2			
<b>PROJECT:</b>		Dimensions are in inches (mm).			
<b>ENGINEER:</b>	<b>DATE</b>	<b>A SERIES</b>	<b>SUPERSEDES</b>	<b>DRAWING NO.</b>	
<b>CONTRACTOR:</b>	5- 15 - 26	1000	4 - 14 - 26	1000-1C	



**LOW LEAKAGE CONTROL DAMPER**  
**STEEL • STANDARD PERFORMANCE**  
**MODELS: 1010 & 1020 WITH 304 STAINLESS STEEL**  
**CONSTRUCTION OPTION**

Nailor Models 1010/1020 with optional 304 Stainless Steel construction provide an enduring solution for corrosive environment commercial and industrial HVAC and process applications. The proven vee groove blade design and sturdy hat channel mitered frame with reinforcing corner gussets afford solid performance that will withstand many normally harsh atmospheric and process elements. The design also features stainless steel zero-maintenance concealed blade linkage for reduced pressure drop and turbulence, and stainless steel axles, bushings and hardware for long lasting operation.

**RATINGS:**

- Velocity:** Up to 3000 fpm (15.2 m/s)
- Pressure:** Up to 5" wg. (1.2 kPa)
- Leakage:** 4 cfm/sq. ft. @ 1" wg (20 l/s/m<sup>2</sup> @ 0.25 kPa)  
8 cfm/sq. ft. @ 4" wg (41 l/s/m<sup>2</sup> @ 1.0 kPa)

**Temperature**

- Range:** -50°F to +180°F (-46°C to +82°C).

**STANDARD CONSTRUCTION:**

- Frame:** 5" x 7/8" x 16 ga. (127 x 22 x 1.6) Type 304 stainless steel hat channel with stainless steel corner gussets. Frame and corner gussets are welded for rigidity. Low profile (flat top and bottom) on dampers 10" (254) high and under.
- Blades:** 6" (152) wide on 5 1/2" (140) centers. 16 ga. (1.6) Type 304 stainless steel vee groove design. Parallel or opposed action.
- Linkage:** Concealed type totally enclosed within the frame and out of the airstream. Type 304 stainless steel.
- Bearings:** 1/2" (13) dia. Celcon®.
- Axles:** 1/2" (13) dia. stainless steel double bolted to blades.
- Drive Shaft:** 6" (152) long x 1/2" (13) dia. Type 304 stainless steel lock-on drive shaft on all single section dampers. A 1/2" (13) or 1" (25) dia. factory installed jackshaft is standard on all multiple section dampers. See multi-section detail 1000 MSI.
- Blade Seals:** Dual durometer bulb type extruded PVC.
- Jamb Seals:** Compression type cambered stainless steel.

**Sizes (Duct W x H):**

Minimum		Maximum	
Single Section		Single Section	Multiple Section
Single Blade 6" x 4" (152 x 102)	Two Blades (parallel or opposed) 6" x 10" (152 x 254)	48" x 72" (1219 x 1829)	Unlimited

**OPTIONS:**

- AMP Actuator mounting side plate
- Other \_\_\_\_\_.

Nailor offers a wide selection of pneumatic and electric actuators for factory or field installation.

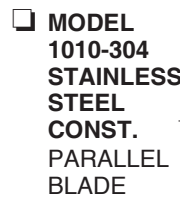
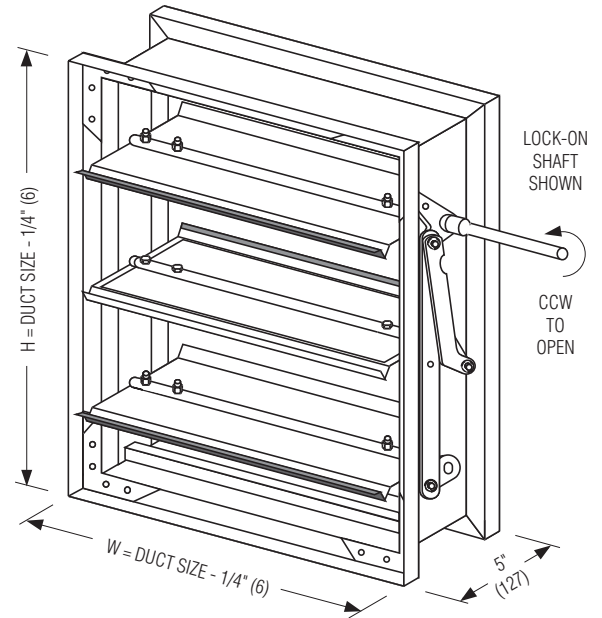

† jackshaft standard on multiple section dampers.

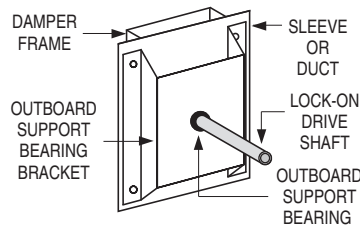
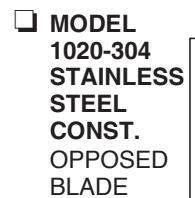

Lock-on drive shaft support bracket detail.

The low profile frame illustrated is used to maximize free area available on units 10" (254) high and under.

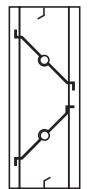

**SCHEDULE TYPE:**

**PROJECT:**

**ENGINEER:**

**CONTRACTOR:**

Page 1 of 2  
 Dimensions are in inches (mm).

DATE	C SERIES	SUPERSEDES	DRAWING NO.
5 - 15 - 26	1000	4 - 14 - 26	1000-1C



**LOW LEAKAGE CONTROL DAMPER**  
**STEEL • STANDARD PERFORMANCE**  
**MODELS: 1010 & 1020 WITH 304 STAINLESS STEEL**  
**CONSTRUCTION OPTION • PERFORMANCE DATA**

**PERFORMANCE DATA:**  
**MODELS: 1010 AND 1020**

**FRAME OPTIONS:**

- FF Flanged Front     FR Flanged Rear     FD Double Flange

**PRESSURE DROP (damper fully open):**

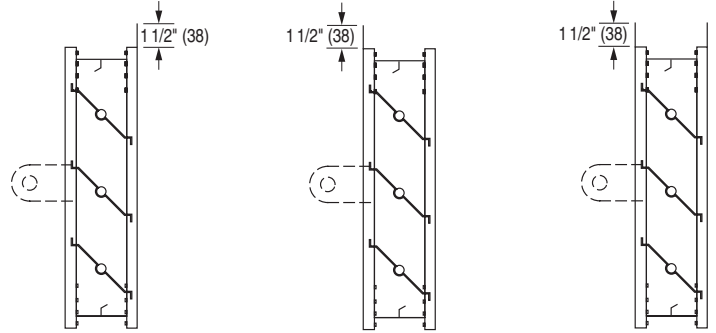
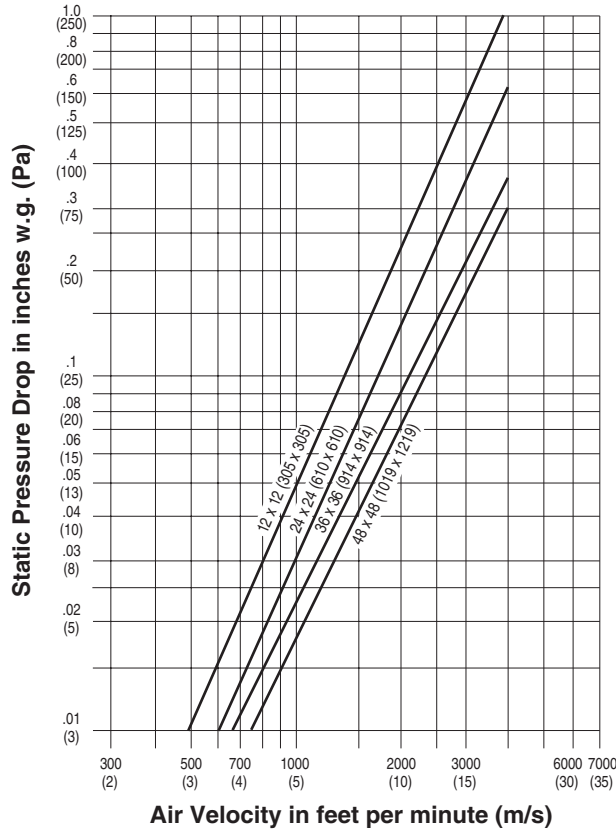

**DYNAMIC LIMITATIONS/LEAKAGE**

Damper Width	Maximum System Pressure	Maximum System Velocity	Leakage *	
			% of Max. Flow	Cfm/ Sq. Ft.
48" (1219)	2.5" w.g.	3000 fpm	0.18	3.5
36" (914)	3.0" w.g.	3000 fpm	0.2	4.0
24" (610)	4.0" w.g.	3000 fpm	0.23	4.5

\* Leakage information is based upon a pressure differential of 1" w.g. tested per AMCA standard 500-D, Fig. 5.5.

<b>SCHEDULE TYPE:</b>	Page 2 of 2			
<b>PROJECT:</b>	Dimensions are in inches (mm).			
<b>ENGINEER:</b>	<b>DATE</b>	<b>C SERIES</b>	<b>SUPERSEDES</b>	<b>DRAWING NO.</b>
<b>CONTRACTOR:</b>	5 - 15 - 26	1000	4 - 14 - 26	1000-1C

The 1012/22 Series are Nailor's most widely used unsealed dampers and are the standard choice for use in the majority of low to medium pressure and velocity commercial HVAC systems. They are low cost, high quality dampers that meet or exceed the majority of standard specification requirements. The design features include a sturdy hat channel frame with die-formed corner gussets for reinforcement and structural strength equivalent to 13 gauge channel type frames, a vee groove blade design that maximizes strength and zero maintenance concealed linkage (out of the air stream) for reduced pressure drop and air turbulence.

**RATINGS:**

**Velocity:** Up to 3000 fpm (15.2 m/s)  
**Pressure:** Up to 5" wg. (1.2 Kpa)  
**Leakage:** 4 cfm/sq. ft. @ 1" wg. (20 l/s/m<sup>2</sup> @ 0.25 kPa)  
 8 cfm/sq. ft. @ 4" wg. (41 l/s/m<sup>2</sup> @ 1.0 kPa)

**Temperature Range:** -50°F to +180°F (-46°C to +82°C)

**STANDARD CONSTRUCTION:**

**Frame:** 5" x 7/8" x 16 ga. (127 x 22 x 1.6) galvanized steel hat channel with die-formed corner gussets. Low profile (flat top and bottom) on dampers 10" (254) high and under.

**Blades:** 6" (152) wide on 5 1/2" (140) centers. 16 ga. (1.6) galv. steel vee groove design. Parallel or opposed action.

**Linkage:** Concealed type totally enclosed within the frame and out of the airstream. Plated steel.

**Bearings:** 1/2" (13) dia. Celcon<sup>®</sup>.

**Axles:** 1/2" (13) dia. plated steel double bolted to blades.

**Drive Shaft:** 6" (152) long x 1/2" (13) dia. rigid drive shaft on all single section dampers. A 1/2" (13) or 1" (25) dia. factory installed jackshaft is standard on all multiple section dampers. See multi-section detail 1000 MSI.

**Sizes (Duct W x H):**

Minimum		Maximum	
Single Section		Single Section	Multiple Section
Single Blade 6" x 4" (152 x 102)	Two Blades (parallel or opposed) 6" x 10" (152 x 254)	48" x 72" (1219 x 1829)	Unlimited

**OPTIONS:**

- BO** Oilite bearings
- 304** Stainless Steel construction
- AMP** Actuator mounting side plate
- BSP** Polyurethane foam blade seals
- JSM** Metallic jamb seals
- DLO** Lock-on drive shaft
- Other \_\_\_\_\_.

Nailor offers a wide selection of pneumatic and electric actuators for factory or field installation.

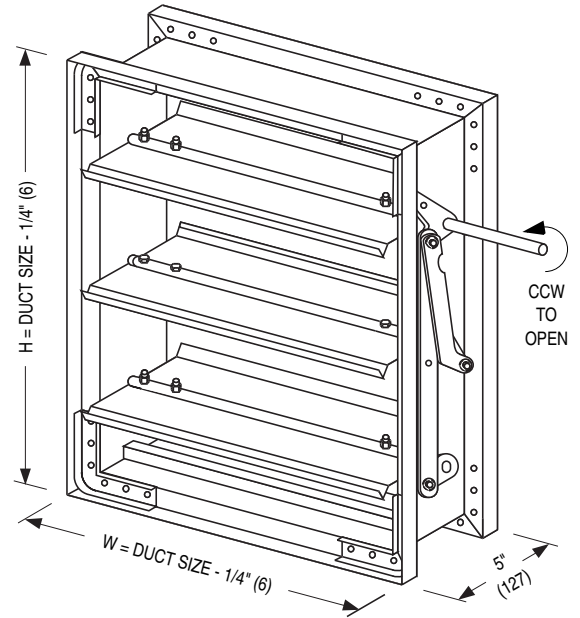
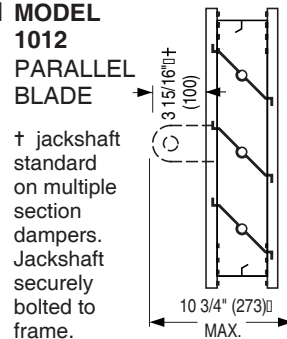
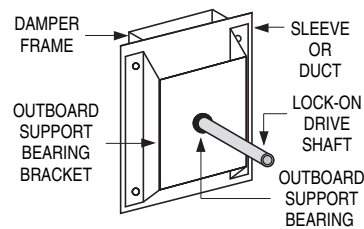
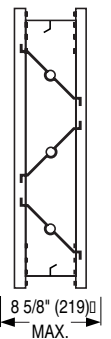
 **MODEL 1012 PARALLEL BLADE**

 **MODEL 1022 OPPOSED BLADE**

Optional lock-on drive shaft support bracket detail.

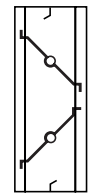
The low profile frame illustrated is used to maximize free area available on units 10" (254) high and under.

**SCHEDULE TYPE:**
**PROJECT:**
**ENGINEER:**
**CONTRACTOR:**

Page 1 of 2  
 Dimensions are in inches (mm).

DATE	A SERIES	SUPERSEDES	DRAWING NO.
2 - 25 - 26	1000	12 - 4 - 12	1000-2

**PERFORMANCE DATA:**  
**MODELS: 1012 AND 1022**

**FRAME OPTIONS:**

- FF** Flanged Front     **FR** Flanged Rear     **FD** Double Flange

**PRESSURE DROP (damper fully open):**

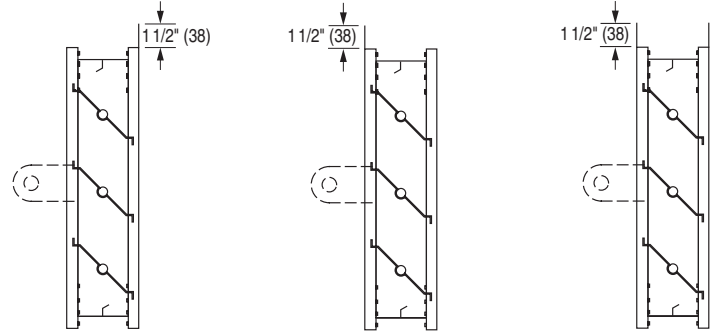
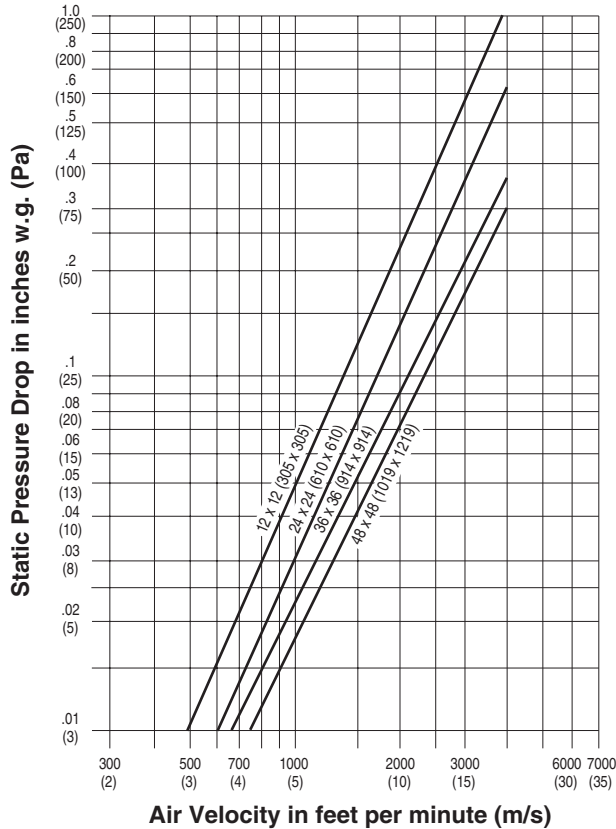

**DYNAMIC LIMITATIONS/LEAKAGE**

Damper Width	Maximum System Pressure	Maximum System Velocity	Leakage *			
			W/O Seals		W/Seals	
			% of Max. Flow	Cfm/ Sq. Ft.	% of Max. Flow	Cfm/ Sq. Ft.
48" (1219)	2.5" w.g.	3000 fpm	1.9	38	0.48	9.5
36" (914)	3.0" w.g.	3000 fpm	2.15	43	0.54	10.8
24" (610)	4.0" w.g.	3000 fpm	2.35	47	0.57	11.3
12" (305)	5.0" w.g.	3000 fpm	3.1	62	0.8	16

\* Leakage information is based upon a pressure differential of 1" w.g. tested per AMCA standard 500-D, Fig. 5.5.

**SCHEDULE TYPE:**

**PROJECT:**

**ENGINEER:**

**CONTRACTOR:**

Page 2 of 2  
 Dimensions are in inches (mm).

**DATE**

**A SERIES**

**SUPERSEDES**

**DRAWING NO.**

2 - 25 - 26

1000

12 - 4 - 12

1000-2



**STANDARD CONTROL DAMPER**  
**STEEL • STANDARD PERFORMANCE**  
**MODELS: 1012 & 1022**

The 1012/22 Series are Nailor's most widely used unsealed dampers and are the standard choice for use in the majority of low to medium pressure and velocity commercial HVAC systems. They are low cost, high quality dampers that meet or exceed the majority of standard specification requirements. The design features include a sturdy hat channel frame with die-formed corner gussets for reinforcement and structural strength equivalent to 13 gauge channel type frames, a vee groove blade design that maximizes strength and zero maintenance concealed linkage (out of the air stream) for reduced pressure drop and air turbulence.

**RATINGS:**

**Velocity:** Up to 3000 fpm (15.2 m/s)  
**Pressure:** Up to 5" wg. (1.2 Kpa)  
**Leakage:** 4 cfm/sq. ft. @ 1" wg. (20 l/s/m<sup>2</sup> @ 0.25 kPa)  
 8 cfm/sq. ft. @ 4" wg. (41 l/s/m<sup>2</sup> @ 1.0 kPa)

**Temperature Range:** -50°F to +180°F (-46°C to +82°C)

**STANDARD CONSTRUCTION:**

- Frame:** 5" x 7/8" x 16 ga. (127 x 22 x 1.6) galvanized steel hat channel with die-formed corner gussets. Low profile (flat top and bottom) on dampers 10" (254) high and under.
- Blades:** 6" (152) wide on 5 1/2" (140) centers. 16 ga. (1.6) galv. steel vee groove design. Parallel or opposed action.
- Linkage:** Concealed type totally enclosed within the frame and out of the airstream. Plated steel.
- Bearings:** 1/2" (13) dia. Celcon®.
- Axles:** 1/2" (13) dia. plated steel double bolted to blades.
- Drive Shaft:** 6" (152) long x 1/2" (13) dia. lock-on drive shaft on all single section dampers. A 1/2" (13) or 1" (25) dia. factory installed jackshaft is standard on all multiple section dampers. See multi-section detail 1000 MSI.

**Sizes (Duct W x H):**

Minimum		Maximum	
Single Section	Single Section	Single Section	Multiple Section
Single Blade 6" x 4" (152 x 102)	Two Blades (parallel or opposed) 6" x 10" (152 x 254)	48" x 72" (1219 x 1829)	Unlimited

**OPTIONS:**

- BO** Oilite bearings
- 304** Stainless Steel construction
- AMP** Actuator mounting side plate
- BSP** Polyurethane foam blade seals
- JSM** Metallic jamb seals
- Other** \_\_\_\_\_.

Nailor offers a wide selection of pneumatic and electric actuators for factory or field installation.

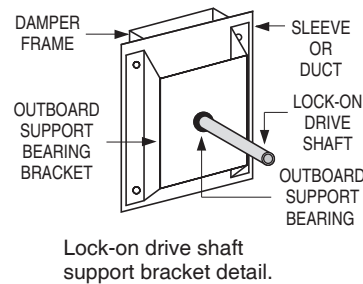
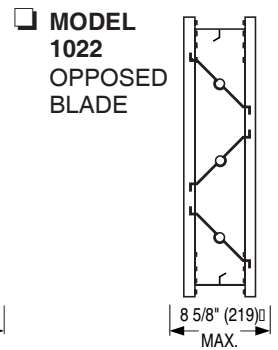
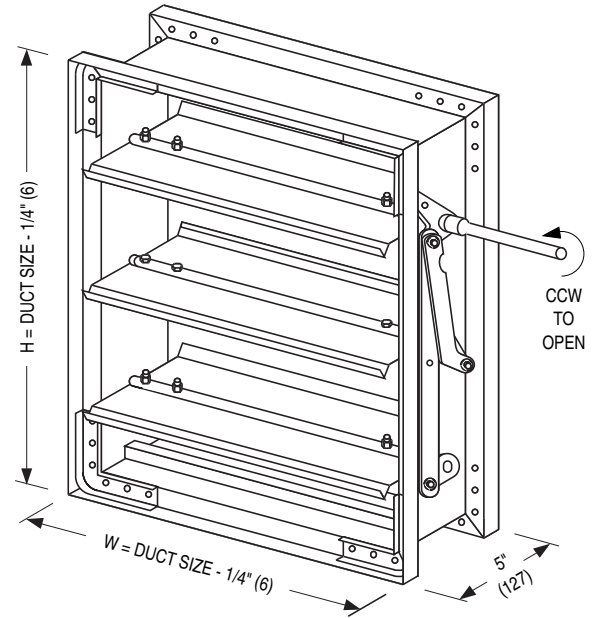

The low profile frame illustrated is used to maximize free area available on units 10" (254) high and under.

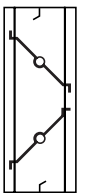

**SCHEDULE TYPE:**

**PROJECT:**

**ENGINEER:**

**CONTRACTOR:**

Page 1 of 2  
 Dimensions are in inches (mm).

DATE	C SERIES	SUPERSEDES	DRAWING NO.
2 - 25 - 26	1000	12 - 4 - 12	1000-2

**PERFORMANCE DATA:**  
**MODELS: 1012 AND 1022**

**FRAME OPTIONS:**

- FF** Flanged Front     **FR** Flanged Rear     **FD** Double Flange

**PRESSURE DROP (damper fully open):**

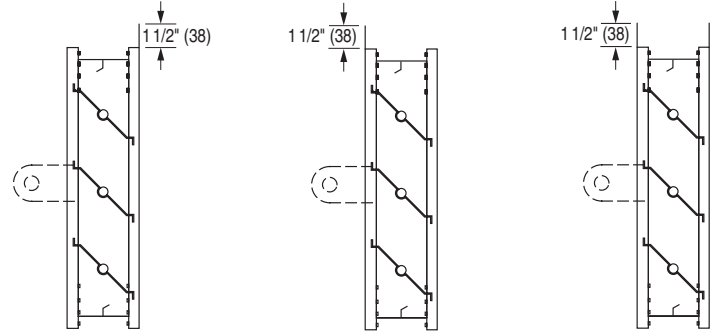
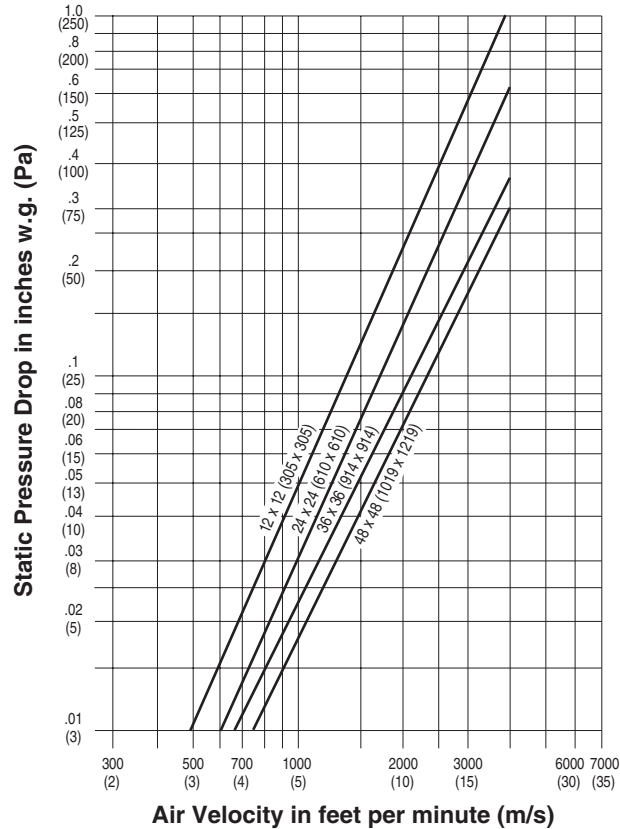

**DYNAMIC LIMITATIONS/LEAKAGE**

Damper Width	Maximum System Pressure	Maximum System Velocity	Leakage *			
			W/O Seals		W/Seals	
			% of Max. Flow	Cfm/ Sq. Ft.	% of Max. Flow	Cfm/ Sq. Ft.
48" (1219)	2.5" w.g.	3000 fpm	1.9	38	0.48	9.5
36" (914)	3.0" w.g.	3000 fpm	2.15	43	0.54	10.8
24" (610)	4.0" w.g.	3000 fpm	2.35	47	0.57	11.3
12" (305)	5.0" w.g.	3000 fpm	3.1	62	0.8	16

\* Leakage information is based upon a pressure differential of 1" w.g. tested per AMCA standard 500-D, Fig. 5.5.

**SCHEDULE TYPE:**

**PROJECT:**

**ENGINEER:**

**CONTRACTOR:**

Page 2 of 2  
 Dimensions are in inches (mm).

**DATE**

**C SERIES**

**SUPERSEDES**

**DRAWING NO.**

2 - 25 - 26

1000

12 - 4 - 12

1000-2



# LOW LEAKAGE CONTROL DAMPER STEEL • STANDARD PERFORMANCE MODELS: 1010 & 1020 WITH CR ROUND TRANSITIONS OPTION

The 1010CR/20CR Series are Nailor's most widely used low leakage multi-blade dampers in a low leakage casing with round transition collars and are the standard choice for use in the majority of commercial HVAC systems. They meet the frequently specified leakage criteria of less than 10 cfm per sq. ft at 4" w.g. (0.5% at 2000 fpm).

### STANDARD CONSTRUCTION:

- Frame:** 5" x 7/8" x 16 ga. (127 x 22 x 1.6) galvanized steel hat channel with die-formed corner gussets. Low profile (flat top and bottom) on dampers 10" (254) high and under.
- Blades:** 6" (152) wide on 5 1/2" (140) centers. 16 ga. (1.6) galvanized steel vee groove design. Parallel or opposed action.
- Linkage:** Concealed type totally enclosed within the frame and out of the airstream. Plated steel.
- Bearings:** 1/2" (13) dia. Celcon®.
- Axles:** 1/2" (13) dia. plated steel double bolted to blades.
- Drive Shaft:** 6" (152) long x 1/2" (13) dia. rigid drive shaft.
- Blade Seals:** Dual durometer bulb type extruded PVC.
- Jamb Seals:** Compression type cambered metal.
- Casing:** Up to 36" x 36" (914 x 914) 20 ga. (1.0) galvanized steel.  
36" x 36" (914 x 914) and up 18 ga. (1.31) galvanized steel.  
Casing is tack-welded and caulked against leakage.

**Temperature Range:** -50°F to +180°F (-46°C to +82°C).

### Sizes (Duct Dia.):

Minimum		Maximum	
Single Section		Single Section	Multiple Section
Single Blade (parallel) 4" (102) dia.	Two Blades (parallel or opposed) 8" (203) dia.	46" (1168) dia.	n/a

### OPTIONS:

- BO** Oilite bearings
- 304** Stainless Steel construction
- Other** \_\_\_\_\_

Nailor offers a wide selection of pneumatic and electric actuators for factory or field installation.

### Performance Data - Air Leakage (Damper Closed)

Damper Width	Maximum System Pressure	Maximum System Velocity	Leakage*	
			% of Max. Flow	Cfm/Sq. Ft.
48" (1219)	2.5" w.g.	2000 fpm	.18	3.5
36" (914)	3.0" w.g.	2000 fpm	.20	4.0
24" (610)	4.0" w.g.	2000 fpm	.23	4.5
12" (305)	5.0" w.g.	2000 fpm	.33	6.6

\* Leakage information is based upon a pressure differential of 1" w.g. tested per AMCA Standard 500-D, Fig. 5.5.

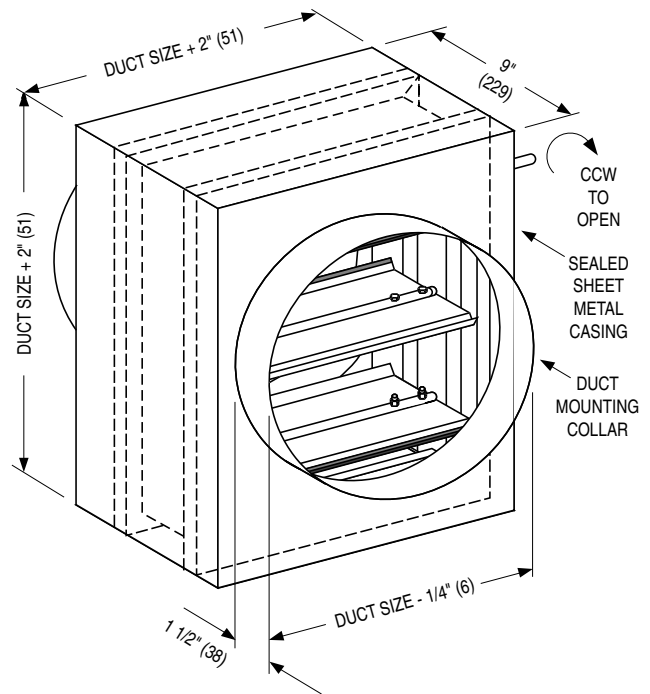

**MODEL 1010CR**  
PARALLEL  
BLADE

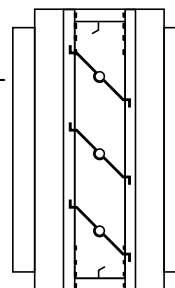

**MODEL 1020CR**  
OPPOSED  
BLADE

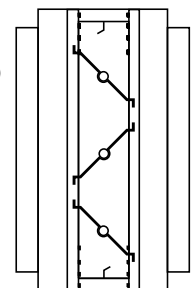

The low profile frame illustrated is used to maximize free area available on units 10" (254) high and under.

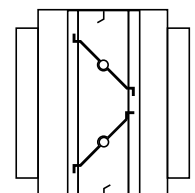

### Pressure Drop (in. w.g.)

Damper Size	Approach Velocity (fpm)			
	750	1000	1500	2000
24" x 24" (610 x 610)	.016	.030	.07	.14
36" x 36" (914 x 914)	.013	.023	.05	.09
48" x 48" (1219 x 1219)	.010	.020	.03	.07

Tested per AMCA Standard 500-D, Fig. 5.3.

### SCHEDULE TYPE:

### PROJECT:

### ENGINEER:

### CONTRACTOR:

Dimensions are in inches (mm).

### DATE

### B SERIES

### SUPERSEDES

### DRAWING NO.

12 - 4 - 12

1000

6 - 30 - 04

1000-3



**CONTROL DAMPER**  
**ROUND • STEEL**  
**LOW LEAKAGE**  
**MODEL: 1090**

Model 1090 is an ultra-low leakage steel butterfly control damper which has been designed for all types of round ductwork applications. Suitable for use in low to medium pressure and velocity commercial HVAC systems, the 1090 installs quickly and easily, saving money on installation costs.

Design features a sturdy beaded casing for superior rigidity, a 14 ga. (2.0) equivalent laminated blade double bolted to the drive shaft for maximum strength, long life corrosion resistant synthetic bearings and blade seals for low leakage requirements. The damper can be used for two position or modulating control using electric or pneumatic actuators and can also be used as a manual balancing damper or when positive shut-off is required by utilizing an optional hand locking quadrant. A variety of options are available to meet specific installation requirements and a comprehensive selection of electric or pneumatic actuators are available for factory or field mounting.

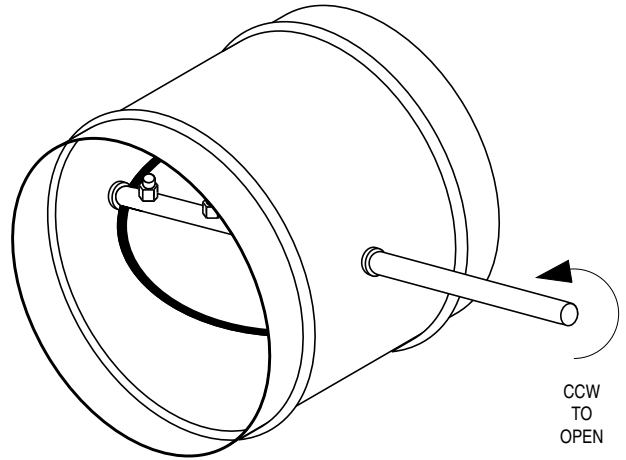

**STANDARD CONSTRUCTION:**

- Frame:** 20 ga. (1.0) corrosion-resistant steel with stiffening beads.
- Blade:** 2 x 20 ga. (1.0) corrosion-resistant steel laminated together, equivalent to 14 ga. (2.0). Open and close end stops. 90 degree rotation. CCW to open.
- Bearings:** 1/2" (13) dia. Celcon®.
- Drive Shaft/Axle:** 1/2" (13) dia. plated steel double bolted to blade. Axle extends approx. 6" (152) beyond frame.
- Blade Seal:** Cross-linked polyethylene.

**Sizes (Duct W x H):**

Minimum	Maximum
Single Section	Single Section
4" (102) dia.	24" (610) dia.

Temperature Range: -50°F to 180°F (-46°C to 82°C)

**OPTIONS:**

- BO** Oilite bearings
- BS** Stainless steel bearings
- HLQ** Hand locking quadrant
- HLQ2** Hand locking quadrant with 2" (51) stand-off bracket
- 304** Type 304 Stainless steel construction
- Special features \_\_\_\_\_.

**ACTUATORS:**

Nailor offers a comprehensive selection of electric and pneumatic actuators for factory or field installation.

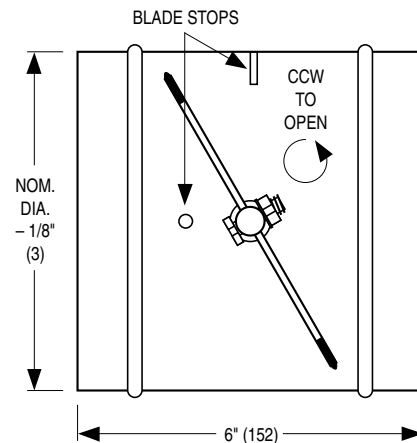

**OPTIONAL HAND LOCKING QUADRANT**

7/8" (22) stand-off

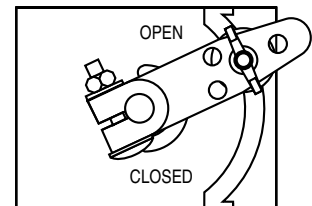

<b>SCHEDULE TYPE:</b>		Page 1 of 2			
<b>PROJECT:</b>		Dimensions are in inches (mm).			
<b>ENGINEER:</b>	<b>DATE</b>	<b>B SERIES</b>	<b>SUPERSEDES</b>	<b>DRAWING NO.</b>	
<b>CONTRACTOR:</b>	4 - 28 - 14	1000	9 - 2 - 09	1000-6	



**CONTROL DAMPER**  
**ROUND • STEEL • LOW LEAKAGE**  
**PERFORMANCE DATA**  
**MODEL: 1090**

**MAXIMUM SYSTEM PRESSURE**

Maximum Damper Diameter	Maximum System Pressure
24" (610)	6" w.g. (1.5 kPa)
18" (457)	6" w.g. (1.5 kPa)
12" (305)	8" w.g. (2 kPa)
6" (152)	10" w.g. (2.5 kPa)

Note: Maximum Face Velocity = 4000 fpm (20 m/s).

**LEAKAGE: CLASS I**

Less than 4 cfm/sq. ft. @ 1" w.g. (0.02 m<sup>3</sup>/s/m<sup>2</sup> @ 250 kPa).  
 Less than 8 cfm/sq. ft. @ 4" w.g. (0.04 m<sup>3</sup>/s/m<sup>2</sup> @ 1 kPa).

**PRESSURE DROP (damper fully open)**

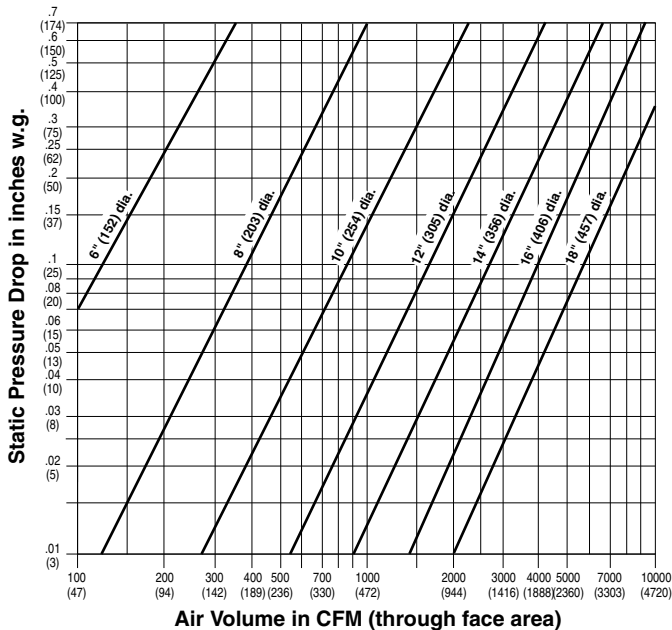

Tested per AMCA standard 500-D, Fig. 5.3.

**AIR LEAKAGE (damper fully closed):**

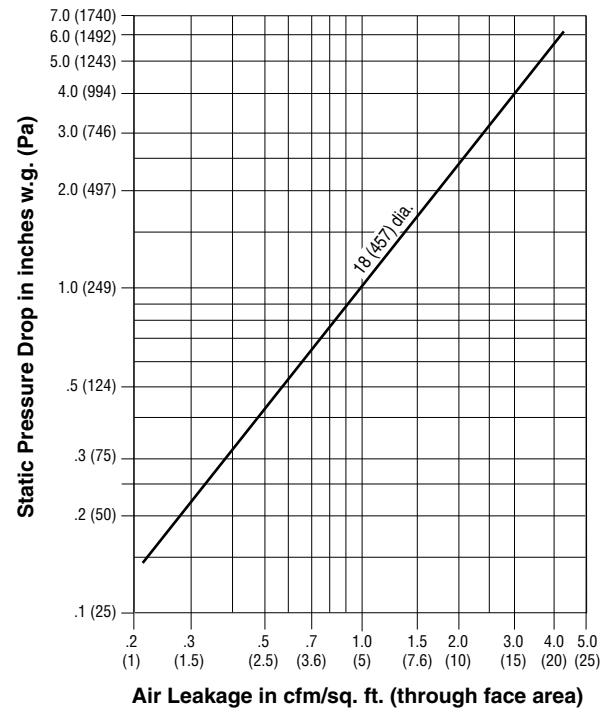

Tested per AMCA standard 500-D, Fig. 5.5.

<b>SCHEDULE TYPE:</b>	Page 2 of 2 Dimensions are in inches (mm).			
<b>PROJECT:</b>				
<b>ENGINEER:</b>	<b>DATE</b>	<b>B SERIES</b>	<b>SUPERSEDES</b>	<b>DRAWING NO.</b>
<b>CONTRACTOR:</b>	4 - 28 - 14	1000	9 - 2 - 09	1000-6



**ROUND CONTROL DAMPER**  
**STEEL • UNIVERSITY OF TEXAS**  
**MODEL: 1091-UT**

The Nailor Model 1091-UT, butterfly damper has been designed for all types of round ductwork applications and is suitable for use in the majority of low to medium pressure and velocity commercial HVAC systems. The damper may be used for two position or modulating control using a variety of electric or pneumatic actuators or may also be used as a manual balancing damper when used with the optional hand locking quadrant and positive shut-off is required.

**STANDARD CONSTRUCTION:**

- FRAME:** 16 ga. (1.6) galvanized steel. Re-inforcing tie-bars on 18" (457) dia. and above.
- BLADE:** 16 ga. (1.6) galvanized steel.
- BEARINGS:** 1/2" (13) dia. oilite bronze.
- DRIVE SHAFT/AXLE:** 1/2" (13) dia. plated steel. One piece continuous with two welded blade straps. Position indicator mark on drive shaft extension.
- BLADE STOP:** 10 ga. (3.5) full perimeter metal blade stop.

**ACTUATOR MOUNTING BASE PLATE:** Factory mounted bracket and baseplate supplied for field mounting of electric or pneumatic actuator.

**AVAILABLE SIZES:** 4" (102) through 20" (508) diameter in nominal 2" (51) increments.

**TEMPERATURE RANGE:** -50°F to 200°F (-45°C to +93°C)

**OPTIONS:**

- HLQ Hand locking quadrant with 1" (25) stand-off bracket.
- HLQ2 Hand locking quadrant with 2" (51) stand-off bracket.
- Siemens 331-4826 factory supplied and mounted pneumatic actuator. NO or NC connection. Specify \_\_\_\_\_.
- Siemens GMA161.1P factory supplied and mounted electric actuator. 24 Vac modulating (0-10 Vac) spring return. Plenum rated cable.
- Special features. Specify \_\_\_\_\_.

**PERFORMANCE:**

Dampers are designed to operate in a clean, dry environment.  
 Maximum System Pressure: 4" w.g. (1 kPa).  
 Maximum Face Velocity: 2000 fpm (10 m/s).

**OPTIONAL HAND LOCKING QUADRANT**

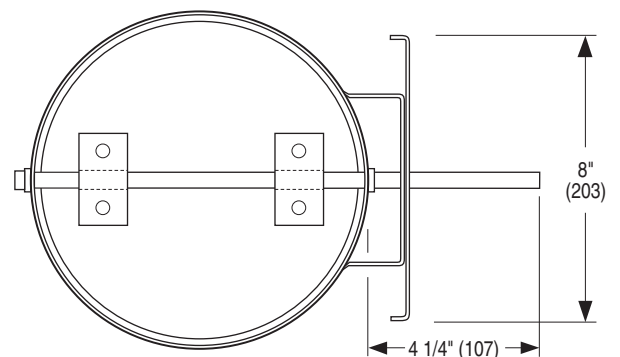
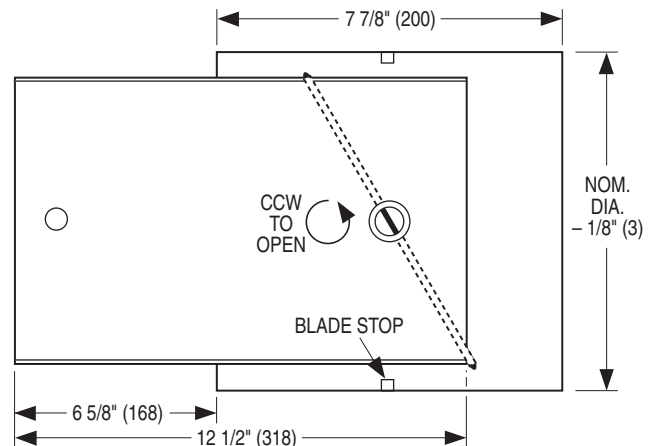
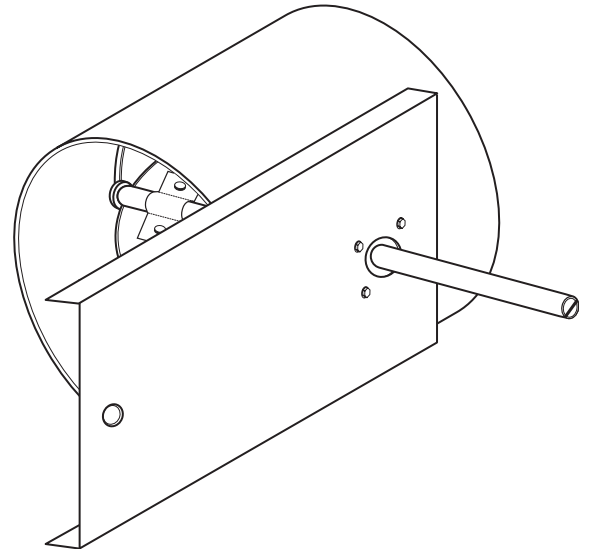
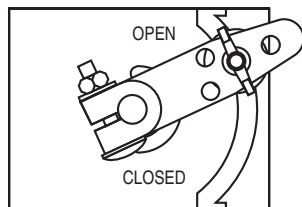

Dimensions are in inches (mm).

<b>SCHEDULE TYPE</b>					
<b>PROJECT</b>					
<b>ENGINEER</b>		<b>DATE</b>	<b>B SERIES</b>	<b>SUPERSEDES</b>	<b>DRAWING NO.</b>
<b>CONTRACTOR</b>		10 - 16 - 25	1000	2 - 14 - 03	1091UT



**HAND LOCKING QUADRANT**  
 FOR USE WITH MANUAL BALANCING AND AIR CONTROL DAMPERS  
**MODEL: CDQUAD (HLQ DAMPER ACCESSORY OPTION)**

**DESCRIPTION:**

The Nailor CDQUAD/HLQ Hand Locking Quadrant is primarily designed for use with the Nailor Multi-Blade 1800 Series Manual Balancing Dampers, 1000, 1100 and 2000 Series Control Dampers.

It mounts directly over a 1/2" (13) dia. lock-on drive shaft or a rigid 1/2" (13) dia. drive shaft and is secured with a carriage bolt.

The CDQUAD is provided with pre-drilled mounting holes for convenient installation and the design ensures that the mounting screws do not interfere with any damper side linkage that may be hidden inside the damper frame channel.

**MATERIAL:**

16 ga. (1.6) galvanized steel 1" (25) stand-off mounting bracket.

Plated steel quadrant and hardware.

Celcon® bearings.

**OPTIONS:**

Accessory when ordered with damper:

- HLQ2 Hand-locking Quadrant with 2" (51) stand-off bracket.

Order separately (by model number):

- CDQUAD NI CD Hand-locking Quadrant - 1/2" (13) dia. shaft.
- CDQUAD2 NI CD Hand-locking Quadrant - 1/2" (13) dia. shaft with 2" (51) stand-off bracket.
- CDQUADSS NI CD Hand-locking Quadrant - 1/2" (13) dia. shaft, Type 304 stainless steel.
- CDQUAD2SS NI CD Hand-locking Quadrant - 1/2" (13) dia. shaft with 2" (51) stand-off bracket, Type 304 stainless steel.

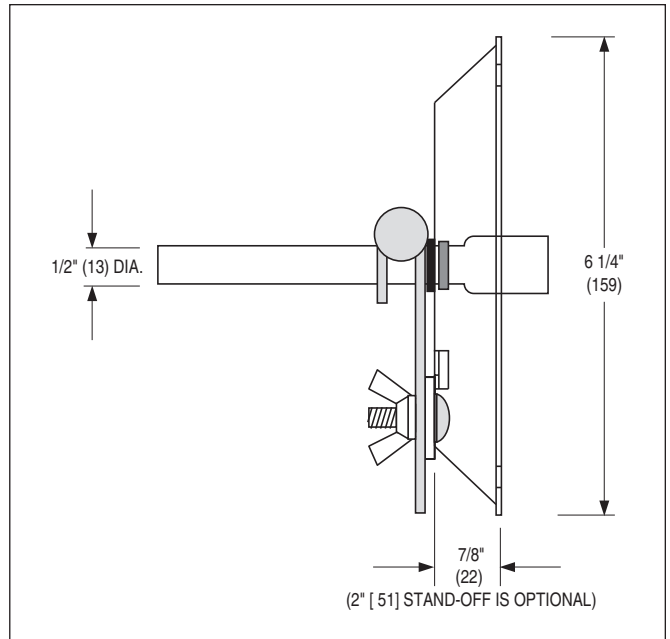

**SIDE VIEW OF HAND QUADRANT**

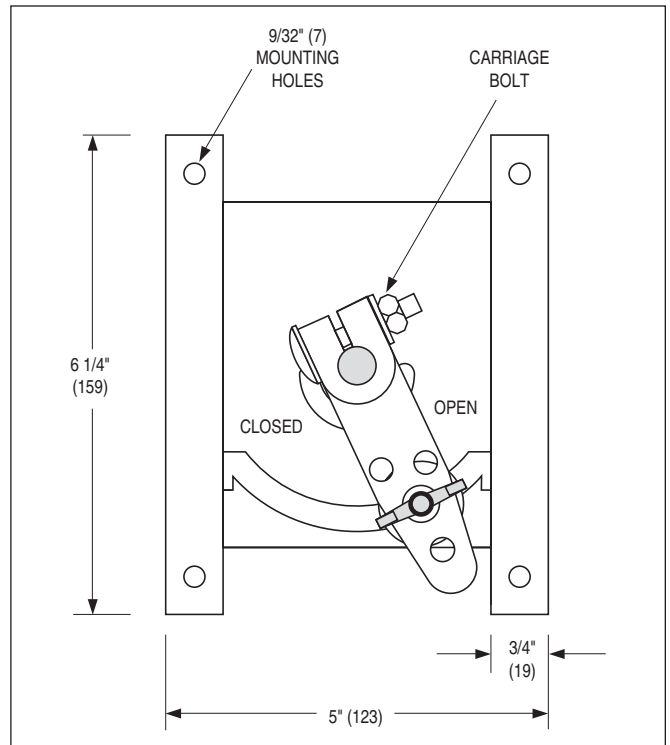

**FACE VIEW OF HAND QUADRANT**

<b>SCHEDULE TYPE:</b>				
<b>PROJECT:</b>				
Dimensions are in inches (mm)				
<b>ENGINEER:</b>	<b>DATE</b>	<b>B SERIES</b>	<b>SUPERSEDES</b>	<b>DRAWING NO.</b>
<b>CONTRACTOR:</b>	12 - 1 - 23	1800	10 - 5 - 99RR	1800-QUAD

## FLANGED FRAME OPTIONS:

Available as an option on Series 1000, 1100 and 2000 steel hat channel frame control dampers, the 1 1/2" (38) flanged frames allow for direct fastening to wall or unit housings as well as flanged ductwork. Damper inside dimension can be sized to match ductwork inside dimension, providing a smooth transition that produces lower pressure drop and less turbulence across the damper. Flange frames are also available with optional 9/32" (7) dia. bolt holes on 6" (152) centers for fast, convenient installation.

### OPTION CODES

- FF** FLANGED FRONT
- FFB** FLANGED FRONT WITH BOLT HOLES

### OPTION CODES

- FR** FLANGED REAR
- FRB** FLANGED REAR WITH BOLT HOLES

### OPTION CODES

- FD** DOUBLE FLANGE
- FDB** DOUBLE FLANGE WITH BOLT HOLES

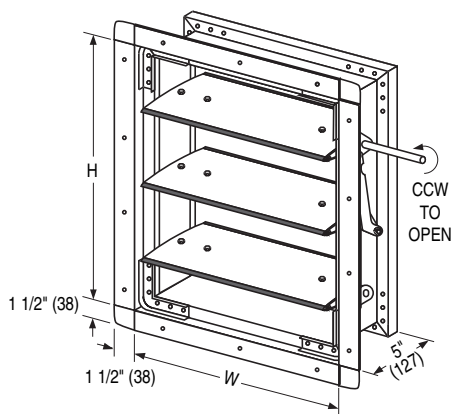
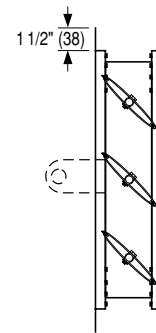
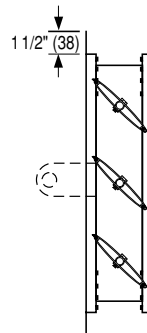
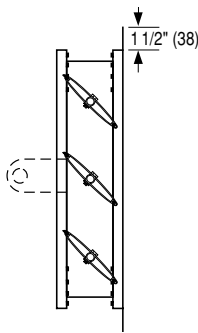

SINGLE SECTION DAMPER SHOWN WITH **FRB** OPTION: FLANGED REAR FRAME WITH 9/32" (7) DIA. BOLT HOLES ON 6" (152) CENTERS.

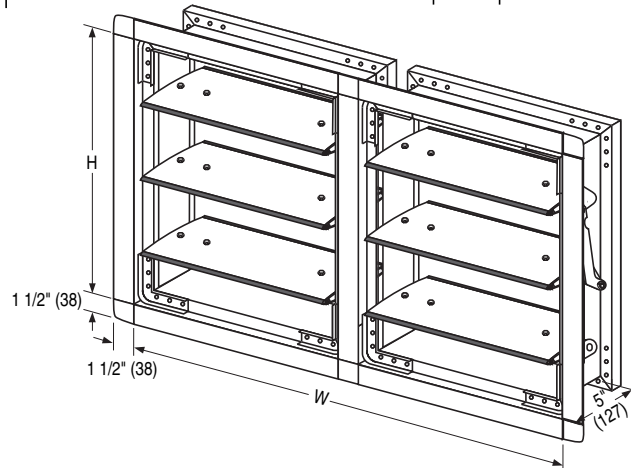

MULTIPLE SECTION DAMPER SHOWN WITH **FR** OPTION: FLANGED REAR FRAME (JACKSHAFT NOT SHOWN)



**SMP SIDE ACTUATOR MOUNTING PLATE  
AND TYPE 'A' SLEEVE DETAIL  
CONTROL & BALANCING DAMPERS  
MODEL SERIES: 1000, 1100, 1800 & 2000**

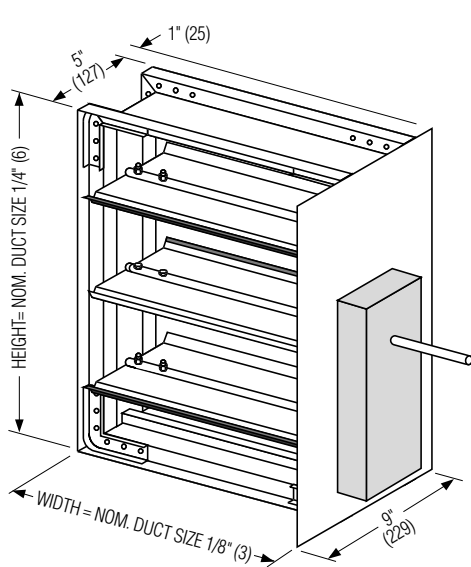

**SMP SIDE ACTUATOR MOUNTING PLATE  
DIRECT DRIVE MODELS**

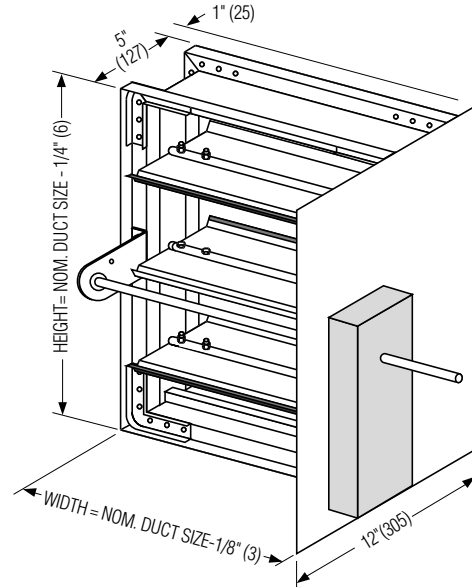

**SMP SIDE ACTUATOR MOUNTING PLATE  
JACKSHAFT DRIVE MODELS**

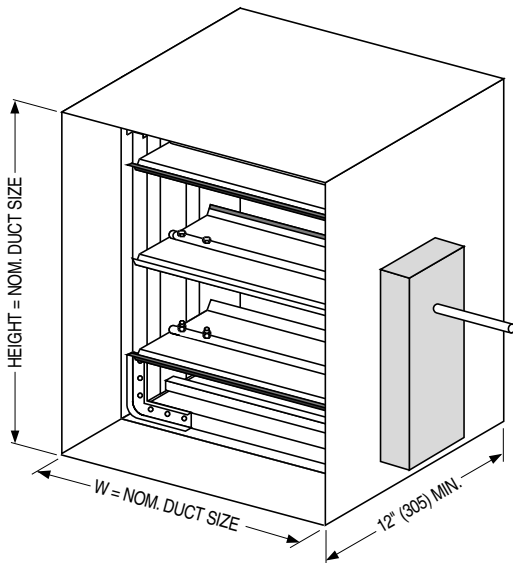

**TYPE 'A' SLEEVE  
DIRECT DRIVE MODELS**

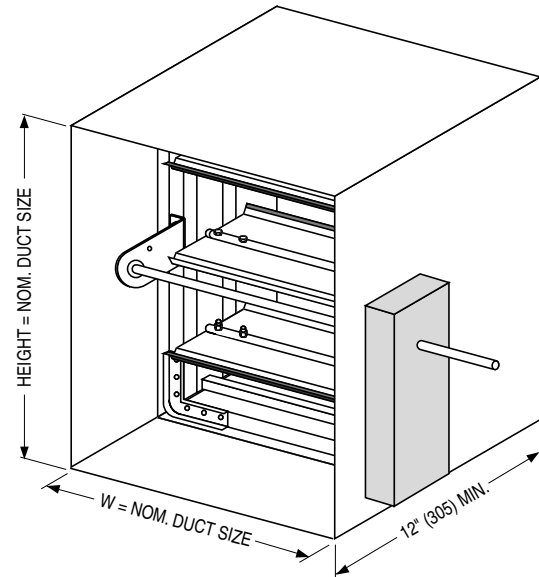

**TYPE 'A' SLEEVE  
JACKSHAFT DRIVE MODELS**

<b>SCHEDULE TYPE:</b>		Dimensions are in inches (mm).			
<b>PROJECT:</b>					
<b>ENGINEER:</b>	<b>DATE</b>	<b>B SERIES</b>	<b>SUPERSEDES</b>	<b>DRAWING NO.</b>	
<b>CONTRACTOR:</b>	11 - 4 - 13	1000	NEW	SMP-SL-2	

**PERFORMANCE DATA:**

**MODELS: 1010 AND 1020**

**PRESSURE DROP (damper fully open):**

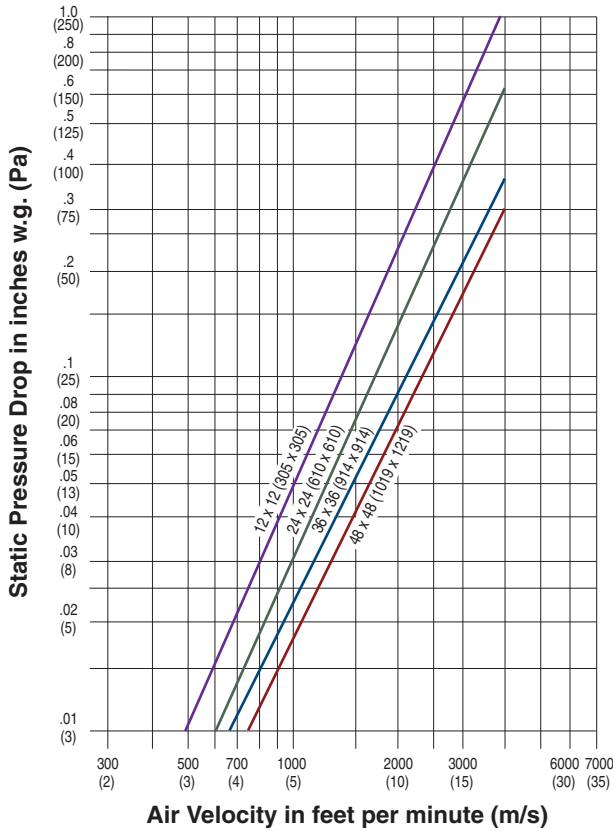

Tested per AMCA standard 500-D, Fig. 5.3.

**LEAKAGE (damper fully closed):**

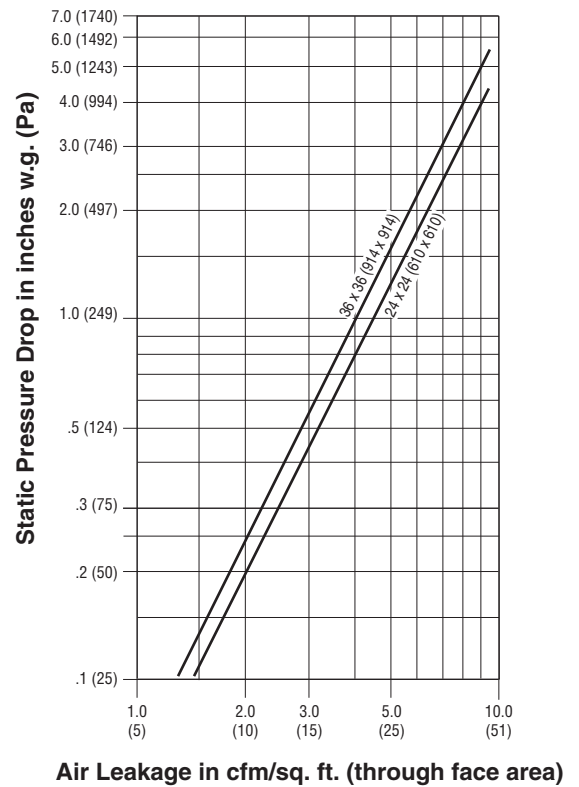

Tested per AMCA standard 500-D, Fig. 5.5.

**DYNAMIC LIMITATIONS/LEAKAGE**

Damper Width	Maximum System Pressure	Maximum System Velocity	Leakage *	
			% of Max. Flow	Cfm/Sq. Ft.
48" (1219)	2.5" w.g.	2000 fpm	.18	3.5
36" (914)	3.0" w.g.	2000 fpm	.20	4.0
24" (610)	4.0" w.g.	2000 fpm	.23	4.5
12" (305)	5.0" w.g.	2000 fpm	.33	6.6

\* Leakage information is based upon a pressure differential of 1" w.g. tested per AMCA standard 500-D, Fig. 5.5.

## PERFORMANCE DATA:

MODELS: 1012 AND 1022

### PRESSURE DROP (damper fully open):

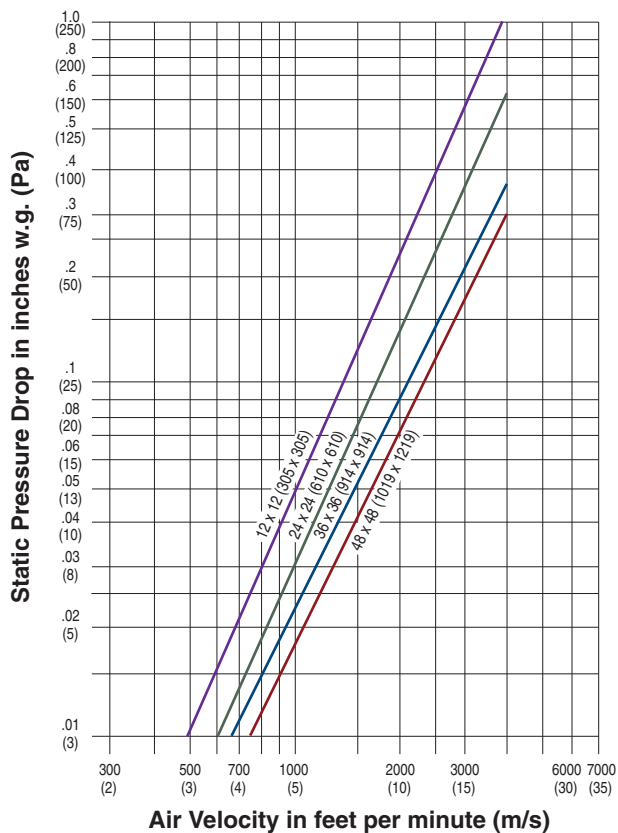

Tested per AMCA standard 500-D, Fig. 5.3.

### LEAKAGE (damper fully closed w/o seals):

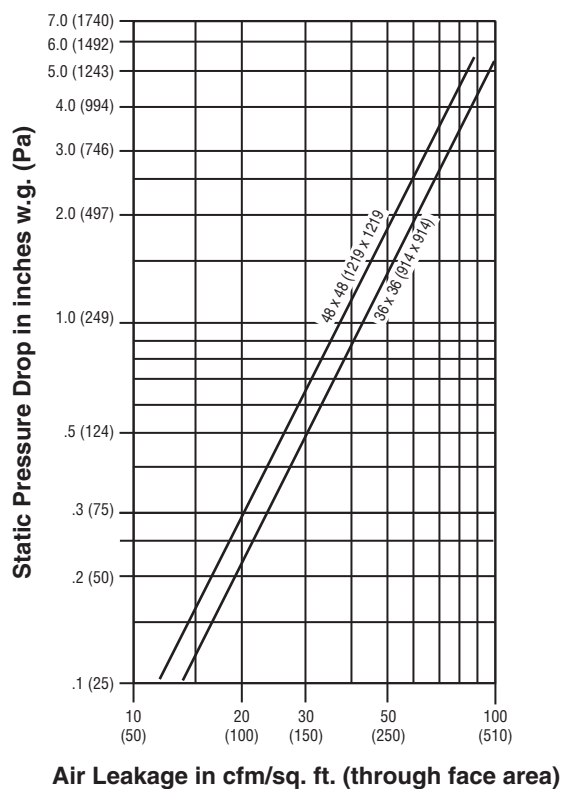

Tested per AMCA standard 500-D, Fig. 5.5.

### DYNAMIC LIMITATIONS/LEAKAGE

Damper Width	Maximum System Pressure	Maximum System Velocity	Leakage *			
			W/O Seals		W/Seals	
			% of Max. Flow	Cfm/Sq. Ft.	% of Max. Flow	Cfm/Sq. Ft.
48" (1219)	2.5" w.g.	2000 fpm	1.90	38	.48	9.5
36" (914)	3.0" w.g.	2000 fpm	2.15	43	.54	10.8
24" (610)	4.0" w.g.	2000 fpm	2.35	47	.57	11.3
12" (305)	5.0" w.g.	2000 fpm	3.10	62	.80	16.0

\* Leakage information is based upon a pressure differential of 1" w.g. tested per AMCA standard 500-D, Fig. 5.5.

**PERFORMANCE DATA:**

**MODEL: 1090**

**PRESSURE DROP (damper fully open):**

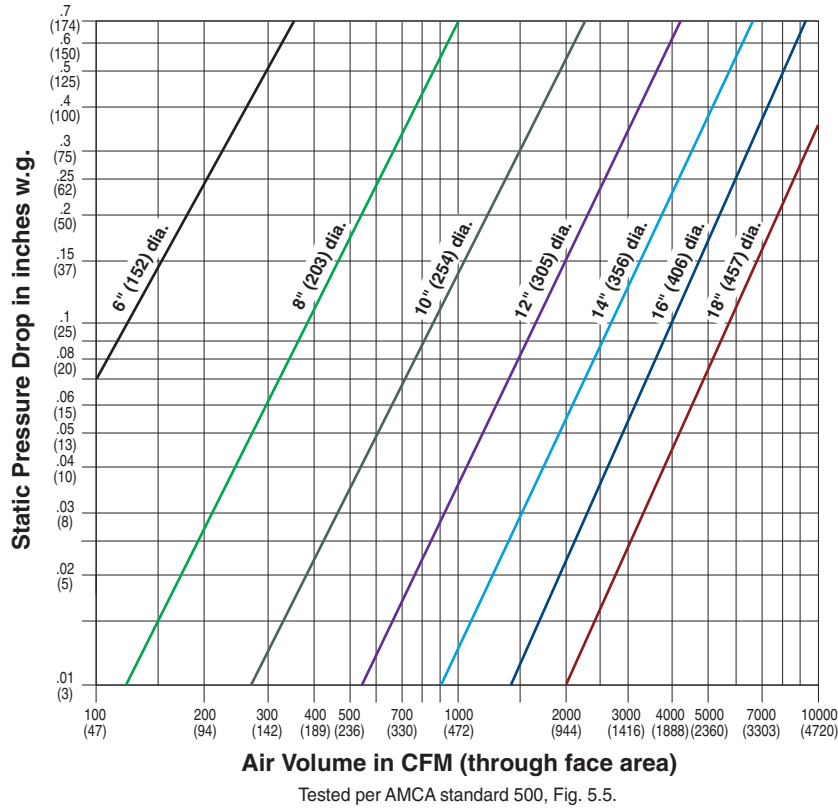

**MAXIMUM SYSTEM PRESSURE**

Maximum Damper Diameter	Maximum System Pressure
24" (610)	6" w.g. (1.5 kPa)
18" (457)	6" w.g. (1.5 kPa)
12" (305)	8" w.g. (2 kPa)
6" (152)	10" w.g. (2.5 kPa)

Note: Maximum Face Velocity = 4000 fpm (20 m/s).

**AIR LEAKAGE (damper fully closed):**

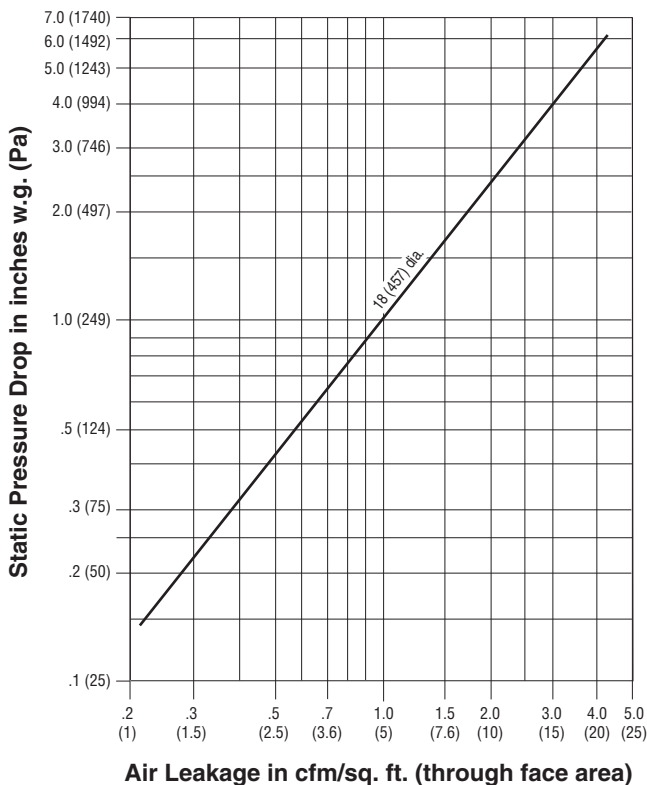

**LEAKAGE: CLASS I**

Less than 4 cfm/sq. ft. @ 1" w.g. (0.02 m<sup>3</sup>/s/m<sup>2</sup> @ 250 kPa).  
 Less than 8 cfm/sq. ft. @ 4" w.g. (0.04 m<sup>3</sup>/s/m<sup>2</sup> @ 1 kPa).

**B**  
**CONTROL DAMPERS**