



LOW PROFILE FAN POWERED TERMINAL UNIT WITH EPIC ECM OR PSC MOTOR
SERIES FLOW • CONSTANT OR VARIABLE VOLUME
MODELS: 37S, 37SW AND 37SE • UNIT SIZES 1 – 3

DESCRIPTION:

- Only 11" (279) high.
- 20 ga. (1.0) galvanized steel construction.
- 16 ga. (1.6) galvanized steel inclined blade damper. 45° rotation. CW to close.
- Multi-point averaging Diamond Flow sensor.
- Access panels top and bottom.
- 1/2" (13) dual density insulation, exposed edges coated to prevent air erosion. Meets requirements of NFPA 90A and UL 181.
- Single point electrical and/or pneumatic main air connection.
- Discharge opening for flanged duct connection.
- Full primary air valve low voltage NEMA 1 type enclosure for factory mounted DDC and analog electronic controls.
- Controls mounted as standard on RH side as shown. Terminals ordered with LH controls (optional) are inverted.

MOTOR OPTIONS:

- Energy efficient PSC fan motor with overload protection. Solid state fan speed controller with minimum voltage stop.
- Ultra-high efficiency ECM fan motor. EPIC fan volume controller.

OPTIONS:

- Filter frame and 1" (25) disposable filter.
- Toggle disconnect switch.
- Steri-liner.
- Fiber-free liner.
- Solid metal liner.
- Perforated metal liner.
- Fan unit fusing.
- Hanger brackets.
- Left-hand controls location.
- FN2 90° Line Voltage Enclosure.
- FN3 Remote Line Voltage Enclosure (see submittal FN3).
- Special features

Model 37S and Basic Unit

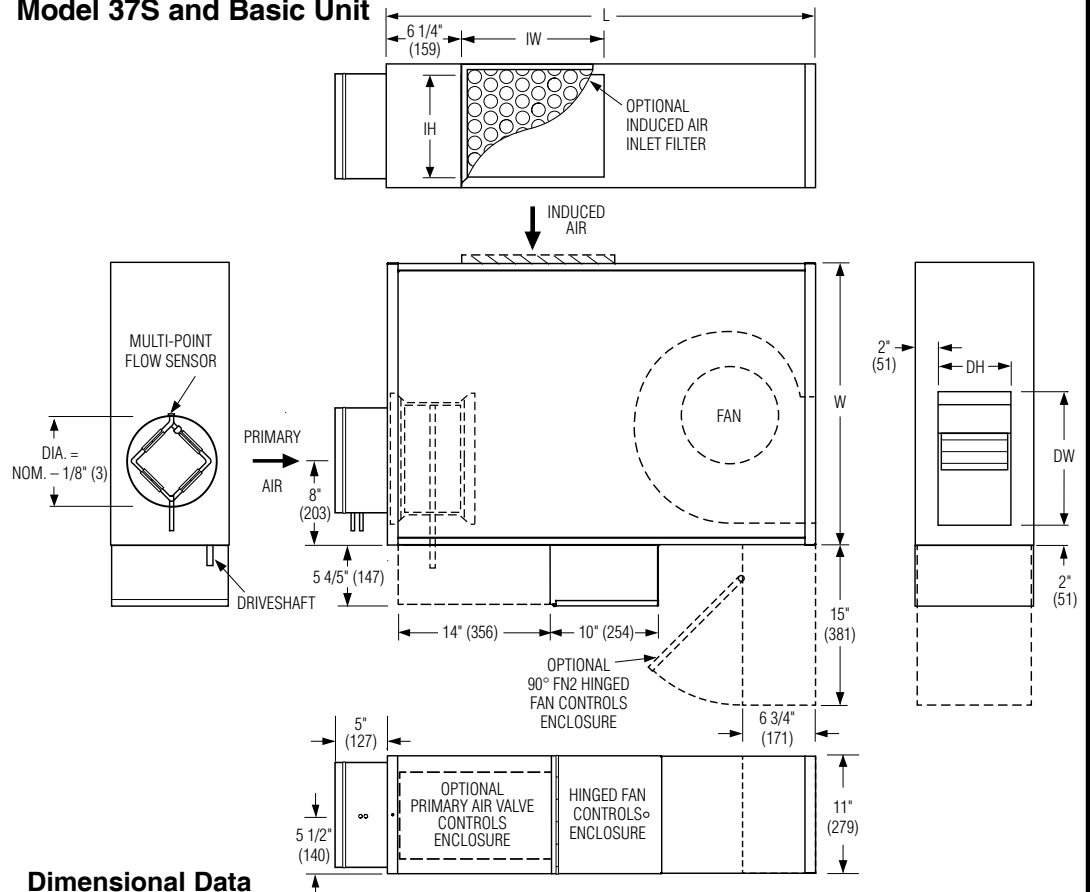

Dimensional Data

Unit Size	Inlet Size	W	L	Induced Air Inlet IW x IH	Outlet Discharge DW x DH	Filter Size
1	4, 5, 6, 8 (102, 127, 152, 203)	19 (483)	36 (914)	6 x 8 (152 x 203)	10 3/8 x 6 7/8 (264 x 175)	8 x 10 (203 x 254)
2	6, 8, 10 (152, 203, 254)	26 1/2 (673)	40 1/4 (1022)	15 3/4 x 8 (400 x 203)	11 3/8 x 6 7/8 (289 x 175)	18 x 10 (457 x 254)
3	6, 8, 10 (152, 203, 254)	26 1/2 (673)	40 1/4 (1022)	15 3/4 x 8 (400 x 203)	12 3/8 x 6 7/8 (314 x 175)	18 x 10 (457 x 254)

Electrical Data

Unit Size	EPIC ECM Motor FLA					PSC Motor FLA				
	Motor HP	120V	208V	240V	277V	Motor HP	120V	208V	240V	277V
1	*	1.9	1.3	1.3	1.3	—	—	—	—	—
2	*	3.3	2.2	2.2	2.2	1/6	4.8	1.8	1.8	1.5
3	*	6.9	4.7	4.4	4.4	1/4	5.3	3.6	3.6	1.8

* The EPIC ECM is a variable horsepower motor.
Refer to Selectworks schedule for actual power consumption.
FLA = Full load amperage. All motors are single phase/60 Hz.



Page 1 of 2. For heat options; see page 2.
Dimensions are in inches (mm).

SCHEDULE TYPE:		DATE	B SERIES	SUPERSEDES	DRAWING NO.
PROJECT:		8 - 13 - 19	3700	8 - 3 - 17	37S-1
ENGINEER:					
CONTRACTOR:					



**LOW PROFILE FAN POWERED TERMINAL UNIT WITH
EPIC ECM OR PSC MOTOR • HEAT ACCESSORIES
SERIES FLOW • CONSTANT OR VARIABLE VOLUME
MODELS: 37SW AND 37SE • UNIT SIZES 1 – 3**

Hot Water Coil Section Model 37SW

Standard Features:

- Coil section installed on unit discharge.
- Coil (and header on multi-circuit units) is installed in insulated casing for increased thermal efficiency.
- 1/2" (13) copper tubes.
- Aluminum ripple fins.
- Sweat connections: One row 1/2" (13) O. D. male solder. Two and three row 7/8" (22) O.D. male solder.
- Top and bottom access panels for inspection and coil cleaning.
- Flanged outlet duct connection.

Coil Rows:

- 1-Row 2-Row 3-Row

Coil Hand Connections:

(Looking in direction of airflow).

- Right hand (illustrated). Standard.
 Left hand. Optional.

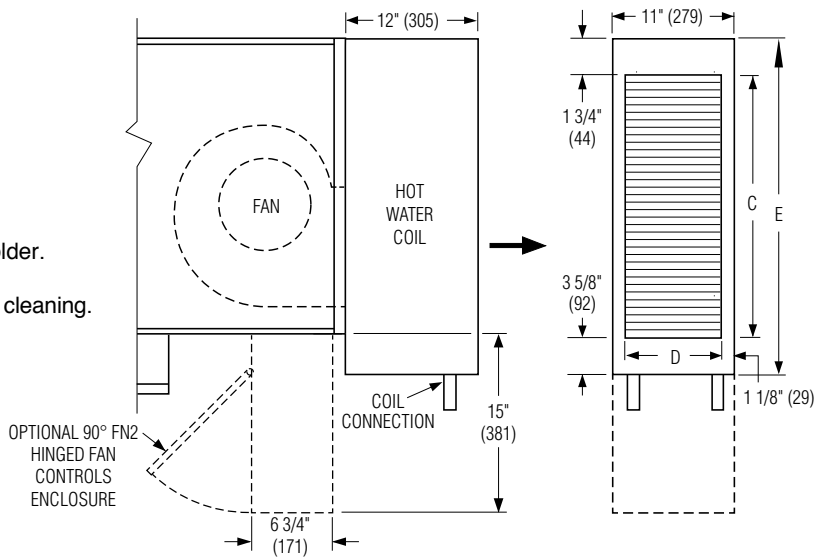

Unit Size	Outlet Duct Size C x D	E
1	14 1/2 x 8 3/4 (368 x 222)	20 (508)
2, 3	24 x 8 3/4 (610 x 222)	29 3/8 (746)

Electric Coil Section Model 37SE

Standard Features:

- Controls enclosure incorporates a hinged access door opening upstream that helps ensure NEC clearance requirements and reduces footprint. (FN2 90° design is standard).
- Unique hinged heater design permits easy access, removal and replacement of heater element without disturbing ductwork.
- Class A 80/20 Ni/Cr wire.
- Coil installed on unit discharge.
- Insulated coil element wrapper.
- Automatic reset high limit cut-outs (one per element).
- Single point electrical connection (except 600V).
- Fan interlock relay or positive pressure airflow switch.
- Flanged outlet duct connection.
- Terminal unit with coil is ETL Listed as an assembly.
- Controls mounted as standard on RH side as shown. Terminals ordered with LH controls (optional) are inverted.

Voltage:

Single phase, 60 Hz.

- 120V 208V 240V 277V

Three phase, 60 Hz.

- 208V 480V (4 wire wye).

- 600V (dual point connection). _____ .

Options:

- Toggle disconnect switch (includes fan). Mercury contactors.
 SCR control. Power circuit fusing.
 Door interlock disconnect switch. Dust tight construction.
 Manual reset secondary thermal cut out.

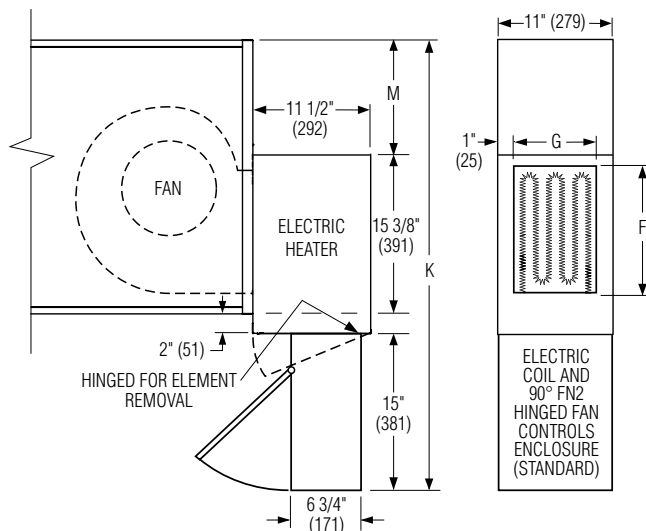

Unit Size	Outlet Duct Size F x G	M	K
1	12 3/8 x 9 (314 x 229)	3 5/8 (92)	35 7/8 (911)
2		11 1/8 (283)	43 1/2 (1105)
3		11 1/8 (283)	43 1/2 (1105)

SCHEDULE TYPE:				
PROJECT:				
ENGINEER:	DATE	B SERIES	SUPERSEDES	DRAWING NO.
CONTRACTOR:	8 - 13 - 19	3700	8 - 3 - 17	37S-1



LOW PROFILE FAN POWERED TERMINAL UNIT WITH EPIC ECM OR PSC MOTOR
SERIES FLOW • CONSTANT OR VARIABLE VOLUME
MODELS: 37S, 37SW AND 37SE • UNIT SIZE 4

DESCRIPTION:

- Only 11" (279) high.
- 20 ga. (1.0) galvanized steel construction.
- 16 ga. (1.6) galvanized steel inclined blade damper. 45° rotation. CW to close.
- Multi-point averaging Diamond Flow sensor.
- Access panels top and bottom.
- 1/2" (13) dual density insulation, exposed edges coated to prevent air erosion. Meets requirements of NFPA 90A and UL 181.
- Single point electrical and/or pneumatic main air connection.
- Discharge opening for flanged duct connection.
- Full primary air valve low voltage NEMA 1 type enclosure for factory mounted DDC and analog electronic controls.
- Controls mounted as standard on RH side as shown. Terminals ordered with LH controls (optional) are inverted.

MOTOR OPTIONS:

- Energy efficient PSC fan motor with overload protection. Solid state fan speed controller with minimum voltage stop.
- Ultra-high efficiency ECM fan motor. EPIC fan volume controller.

OPTIONS:

- Filter frame and 1" (25) disposable filter.
- Toggle disconnect switch.
- Steri-liner.
- Fiber-free liner.
- Solid metal liner.
- Perforated metal liner.
- Fan unit fusing.
- Hanger brackets.
- Left-hand controls location.
- FN2 90° Line Voltage Enclosure.
- FN3 Remote Line Voltage Enclosure (see submittal FN3).
- Special features

Model 37S and Basic Unit

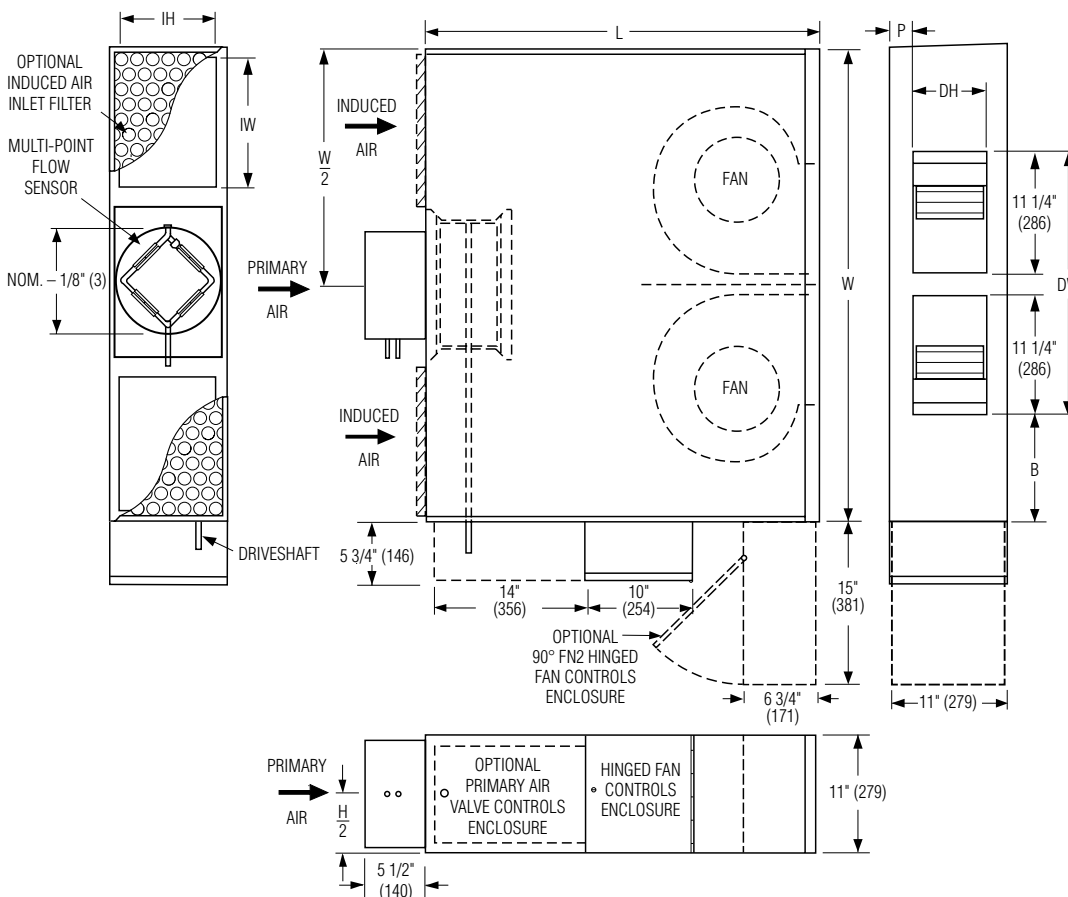

Dimensional Data

Unit Size	Inlet Size	W	L	B	P	Induced Air Inlet IW x IH	Outlet Discharge DW x DH	Filter Size
4	10 (254) Round 14 x 10 (356 x 254) Rect.	44 (1118)	36 1/2 (927)	9 3/4 (248)	2 1/16 (52)	12 x 9 (305 x 229) Qty. of 2	24 1/2 x 6 7/8 (622 x 175)	14 x 10 (356 x 254) Qty. of 2

Electrical Data

Unit Size	EPIC ECM Motor FLA					PSC Motor FLA				
	Motor HP	120V	208V	240V	277V	Motor HP	120V	208V	240V	277V
4	*	8.2	5.5	5.3	5.3	2 @ 1/4	10.6	7.2	7.2	3.7

* The EPIC ECM is a variable horsepower motor. Refer to Selectworks schedule for actual power consumption. FLA = Full load amperage. All motors are single phase/60 Hz.



SCHEDULE TYPE:		DATE	B SERIES	SUPERSEDES	DRAWING NO.
PROJECT:		8 - 13 - 19	3700	7 - 18 - 17	37S-2
ENGINEER:					
CONTRACTOR:					



**LOW PROFILE FAN POWERED TERMINAL UNIT WITH
EPIC ECM OR PSC MOTOR • HEAT ACCESSORIES
SERIES FLOW • CONSTANT OR VARIABLE VOLUME
MODELS: 37SW AND 37SE • UNIT SIZE 4**

Hot Water Coil Section Model 37SW

Standard Features:

- Coil section installed on unit discharge.
- Coil (and header on multi-circuit units) is installed in insulated casing for increased thermal efficiency.
- 1/2" (13) copper tubes.
- Aluminum ripple fins.
- Sweat connections: One row 1/2" (13) O.D. male solder. Two and three row 7/8" (22) O. D. male solder.
- Top and bottom access panels for inspection and coil cleaning.
- Flanged outlet duct connection.

Coil Rows:

- 1-Row 2-Row 3-Row

Coil Hand Connections:

(Looking in direction of airflow).

- Right hand (illustrated). Standard.
 Left hand. Optional.

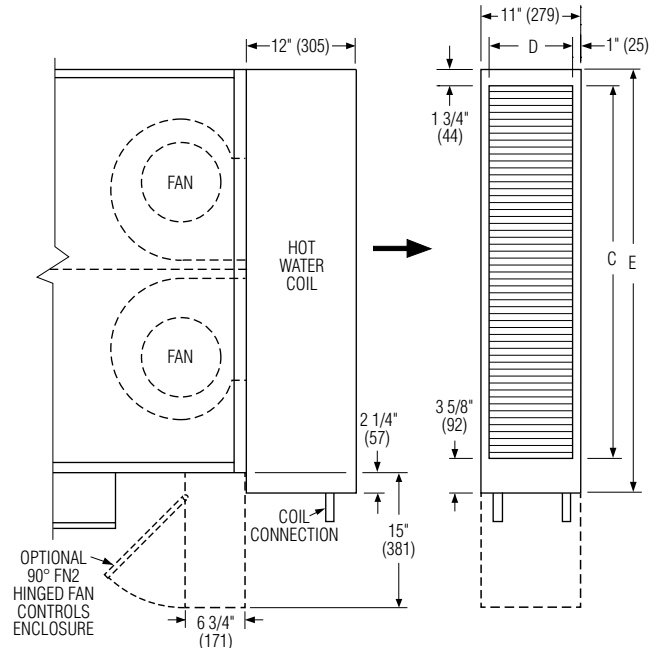

Unit Size	Outlet Duct Size C x D	E
4	41 x 9 (1041 x 229)	46 3/8 (1178)

Electric Coil Section Model 37SE

Standard Features:

- Controls enclosure incorporates a hinged access door opening upstream that helps ensure NEC clearance requirements and reduces footprint. (FN2 90° design is standard).
- Unique hinged heater design permits easy access, removal and replacement of heater element without disturbing ductwork.
- Class A 80/20 Ni/Cr wire.
- Coil installed on unit discharge.
- Insulated coil element wrapper.
- Automatic reset high limit cut-outs (one per element).
- Single point electrical connection (except 600V).
- Fan interlock relay or positive pressure airflow switch.
- Flanged outlet duct connection.
- Terminal unit with coil is ETL Listed as an assembly.
- Controls mounted as standard on RH side as shown. Terminals ordered with LH controls (optional) are inverted.

Voltage:

Single phase, 60 Hz.

- 120V 208V 240V 277V

Three phase, 60 Hz.

- 208V 480V (4 wire wye).

- 600V (dual point connection). _____

Options:

- Toggle disconnect switch (includes fan). Power circuit fusing.
 SCR control. Dust tight construction.
 Door interlock disconnect switch. Manual reset secondary thermal cut out.
 Mercury contactors.

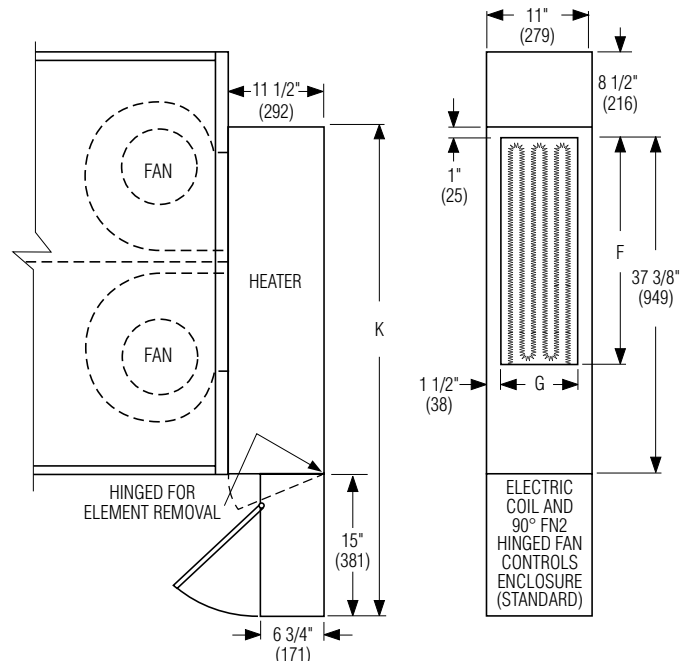

Unit Size	Outlet Duct Size F x G	K
4	25 x 8 (635 x 203)	52 3/8 (1330)

SCHEDULE TYPE:

PROJECT:

ENGINEER:

CONTRACTOR:

Page 2 of 2.
Dimensions are in inches (mm).

DATE	B SERIES	SUPERSEDES	DRAWING NO.
8 - 13 - 19	3700	7 - 18 - 17	37S-2



**LOW PROFILE FAN POWERED TERMINAL UNIT WITH
EPIC ECM OR PSC MOTOR
'STEALTH™' • SERIES FLOW • CONSTANT OR VARIABLE VOLUME
MODELS: 37SST, 37SEST AND 37SWST
UNIT SIZES 1 – 3**

DESCRIPTION:

- Only 11" (279) high.
- 20 ga. (1.0) galvanized steel construction.
- 16 ga. (1.6) galvanized steel inclined blade damper. 45° rotation. CW to close.
- 'Stealth™' tuned inlet attenuator.
- Multi-point averaging Diamond Flow sensor.
- Access panels top and bottom.
- 1/2" (13) dual density insulation, exposed edges coated to prevent air erosion. Meets requirements of NFPA 90A and UL 181.
- Single point electrical and/or pneumatic main air connection.
- Discharge opening for flanged duct connection.
- Full primary air valve low voltage NEMA 1 type enclosure for factory mounted DDC and analog electronic controls.
- Controls mounted as standard on RH side as shown. Terminals ordered with LH controls (optional) are inverted.

Model 37SST and Basic Unit

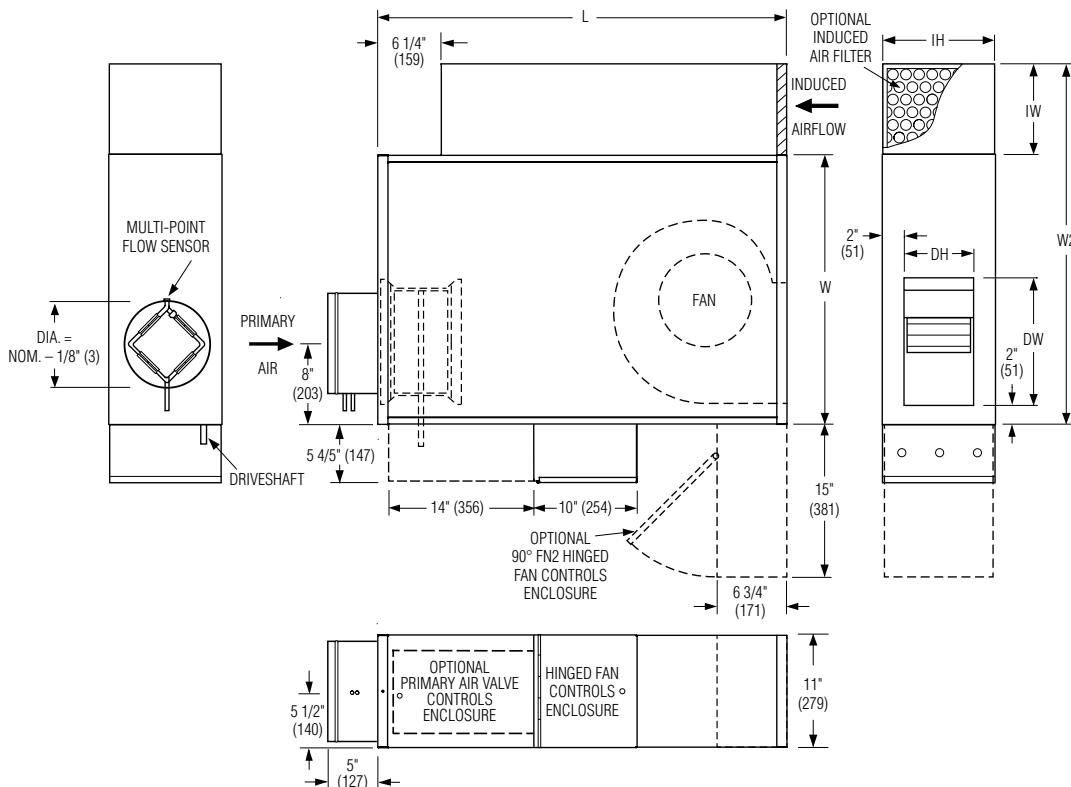

MOTOR OPTIONS:

- Energy efficient PSC fan motor with overload protection. Solid state fan speed controller with minimum voltage stop.
- Ultra-high efficiency ECM fan motor. EPIC fan volume controller.

OPTIONS:

- Filter frame and 1" (25) disposable filter.
- Toggle disconnect switch.
- Steri-liner.
- Fiber-free liner.
- Solid metal liner.
- Perforated metal liner.
- Fan unit fusing.
- Hanger brackets.
- Left-hand controls location.
- FN2 90° Line Voltage Enclosure.
- FN3 Remote Line Voltage Enclosure (see submittal FN3).
- Special features

Dimensional Data

Unit Size	Inlet Size	W	W2	L	Induced Air Inlet IW x IH	Outlet Discharge DW x DH	Filter Size
1	4, 5, 6, 8 (102, 127, 152, 203)	19 (483)	28 (711)	36 (914)	9 x 11 (229 x 279)	10 3/8 x 6 7/8 (264 x 175)	9 x 11 (229 x 279)
2	6, 8, 10 (152, 203, 254)	26 1/2 (673)	38 1/2 (978)	40 1/4 (1022)	12 x 11 (305 x 279)	11 3/8 x 6 7/8 (289 x 175)	12 x 11 (305 x 279)
3	6, 8, 10 (152, 203, 254)	26 1/2 (673)	38 1/2 (978)	40 1/4 (1022)	12 x 11 (305 x 279)	12 3/8 x 6 7/8 (314 x 175)	12 x 11 (305 x 279)

Electrical Data

Unit Size	EPIC ECM Motor FLA					PSC Motor FLA				
	Motor HP	120V	208V	240V	277V	Motor HP	120V	208V	240V	277V
1	*	1.9	1.3	1.3	1.3	—	—	—	—	—
2	*	3.3	2.2	2.2	2.2	1/6	4.8	1.8	1.8	1.5
3	*	6.9	4.7	4.4	4.4	1/4	5.3	3.6	3.6	1.8

* The EPIC ECM is a variable horsepower motor.
Refer to Selectworks schedule for actual power consumption.
FLA = Full load amperage. All motors are single phase/60 Hz.



SCHEDULE TYPE:				
PROJECT:				
ENGINEER:	DATE	B SERIES	SUPERSEDES	DRAWING NO.
CONTRACTOR:	4 - 25 - 22	3700	8 - 13 - 19	37SST-1



**LOW PROFILE FAN POWERED TERMINAL UNIT WITH
EPIC ECM OR PSC MOTOR • HEAT ACCESSORIES
'STEALTH™' • SERIES FLOW
CONSTANT OR VARIABLE VOLUME
MODELS: 37SWST AND 37SEST • UNIT SIZES 1 – 3**

Hot Water Coil Section Model 37SWST

Standard Features:

- Coil section installed on unit discharge.
- Coil (and header on multi-circuit units) is installed in insulated casing for increased thermal efficiency.
- 1/2" (13) copper tubes.
- Aluminum ripple fins.
- Sweat connections: One row 1/2" (13) O. D. male solder. Two and three row 7/8" (22) O.D. male solder.
- Top and bottom access panels for inspection and coil cleaning.
- Flanged outlet duct connection.

Coil Rows:

- 1-Row 2-Row 3-Row

Coil Hand Connections:

(Looking in direction of airflow).

- Right hand (illustrated). Standard.
 Left hand (terminals are inverted). Optional.

Connections must be selected same hand as controls enclosure location.

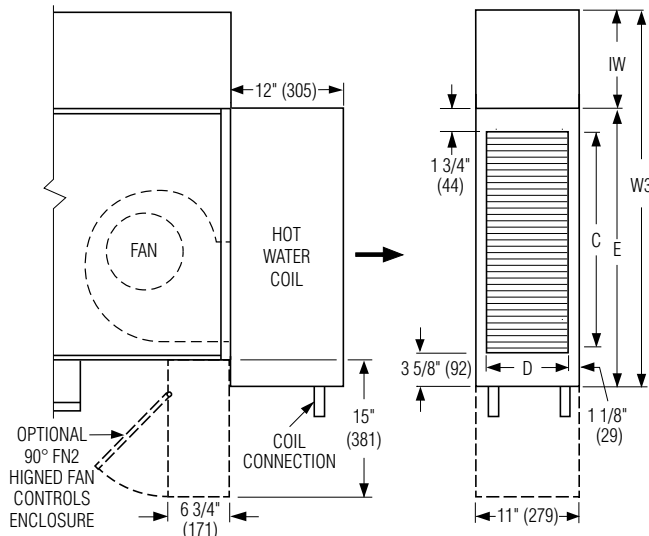

Unit Size	Outlet Duct Size C x D	IW	W3	E
1	14 1/2 x 8 3/4 (368 x 222)	9 (229)	29 (737)	20 (508)
2, 3	24 x 8 3/4 (610 x 222)	12 (305)	41 3/8 (1051)	29 3/8 (746)

Electric Coil Section Model 37SEST

Standard Features:

- Controls enclosure incorporates a hinged access door opening upstream that helps ensure NEC clearance requirements and reduces footprint. (FN2 90° design is standard).
- Unique hinged heater design permits easy access, removal and replacement of heater element without disturbing ductwork.
- Class A 80/20 Ni/Cr wire.
- Coil installed on unit discharge.
- Insulated coil element wrapper.
- Automatic reset high limit cut-outs (one per element).
- Single point electrical connection (except 600V).
- Fan interlock relay or positive pressure airflow switch.
- Flanged outlet duct connection.
- Terminal unit with coil is ETL Listed as an assembly.
- Controls mounted as standard on RH side as shown. Terminals ordered with LH controls (optional) are inverted.

Voltage:

Single phase, 60 Hz.

- 120V 208V 240V 277V

Three phase, 60 Hz.

- 208V 480V (4 wire wye).

- 600V (dual point connection). _____

Options:

- Toggle disconnect switch (includes fan). Mercury contactors.
 SCR control. Power circuit fusing.
 Door interlock disconnect switch. Dust tight construction.
 Manual reset secondary thermal cut out.

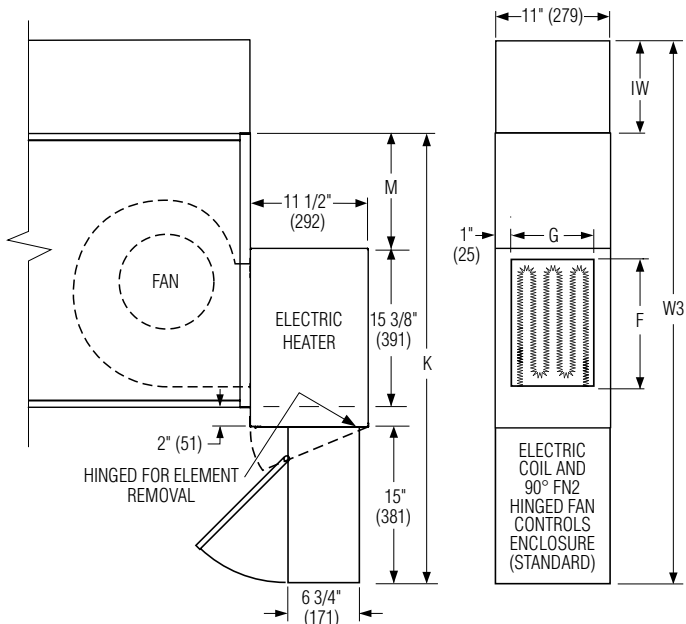

Unit Size	Outlet Duct Size F x G	IW	M	W3	K
1	12 3/8 x 9 (314 x 229)	9 (229)	3 5/8 (92)	44 7/8 (1140)	35 7/8 (911)
2			11 1/8 (283)	52 1/2 (1334)	43 1/2 (1105)
3			11 1/8 (283)	52 1/2 (1334)	43 1/2 (1105)

SCHEDULE TYPE:	Page 2 of 2.			
PROJECT:	Dimensions are in inches (mm).			
ENGINEER:	DATE	B SERIES	SUPERSEDES	DRAWING NO.
CONTRACTOR:	4 - 25 - 22	3700	8 - 13 - 19	37SST-1



**LOW PROFILE FAN POWERED TERMINAL UNIT WITH
EPIC ECM OR PSC MOTOR
'STEALTH™' • SERIES FLOW
CONSTANT OR VARIABLE VOLUME
MODELS: 37SST, 37SEST AND 37SWST • UNIT SIZE 4**

DESCRIPTION:

- Only 11" (279) high.
- 20 ga. (1.0) galvanized steel construction.
- 16 ga. (1.6) galvanized steel inclined blade damper. 45° rotation. CW to close.
- 'Stealth™' tuned inlet attenuators (2). Shipped loose for field mounting.
- Multi-point averaging Diamond Flow sensor.
- Access panels top and bottom.
- 1/2" (13) dual density insulation, exposed edges coated to prevent air erosion. Meets requirements of NFPA 90A and UL 181.
- Single point electrical and/or pneumatic main air connection.
- Discharge opening for flanged duct connection.
- Full primary air valve low voltage NEMA 1 type enclosure for factory mounted DDC and analog electronic controls.
- Controls mounted as standard on RH side as shown. Terminals ordered with LH controls (optional) are inverted.

MOTOR OPTIONS:

- Energy efficient PSC fan motor with overload protection. Solid state fan speed controller with minimum voltage stop.
- Ultra-high efficiency ECM fan motor. EPIC fan volume controller.

OPTIONS:

- Filter frame and 1" (25) disposable filter.
- Toggle disconnect switch.
- Steri-liner.
- Fiber-free liner.
- Solid metal liner.
- Perforated metal liner.
- Fan unit fusing.
- Hanger brackets.
- Left-hand controls location.
- FN2 90° Line Voltage Enclosure.
- FN3 Remote Line Voltage Enclosure (see submittal FN3).
- Special features

Model 37SST and Basic Unit

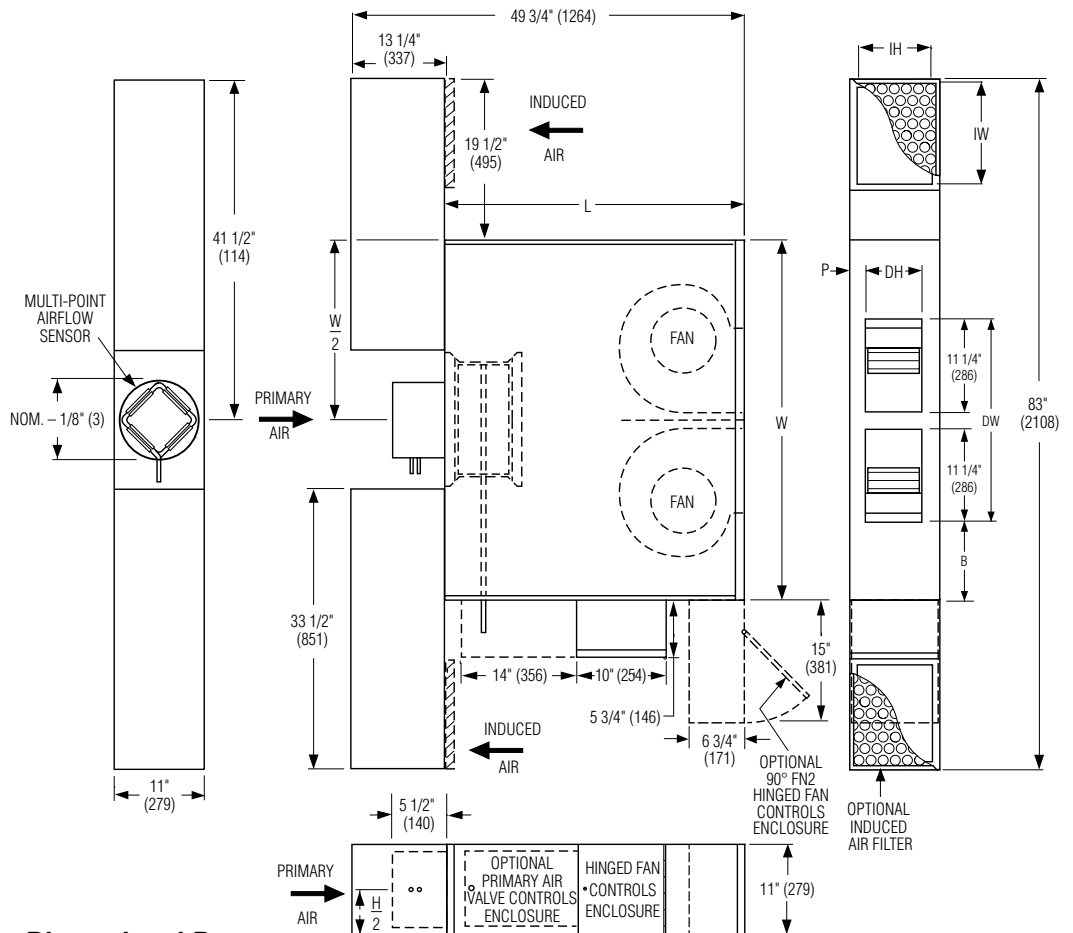

Dimensional Data

Unit Size	Inlet Size	W	L	B	P	Induced Air Inlet IW x IH	Outlet Discharge DW x DH	Filter Size
4	10 (254) Round 14 x 10 (356 x 254) Rect.	44 (1118)	36 1/2 (927)	9 3/4 (248)	2 1/16 (52)	12 x 9 (305 x 229) Qty. of 2	24 1/2 x 6 7/8 (622 x 175)	14 x 10 (356 x 254) Qty. of 2

Electrical Data

Unit Size	EPIC ECM Motor FLA					PSC Motor FLA				
	Motor HP	120V	208V	240V	277V	Motor HP	120V	208V	240V	277V
4	*	8.2	5.5	5.3	5.3	2 @ 1/4	10.6	7.2	7.2	3.7

* The EPIC ECM is a variable horsepower motor. Refer to Selectworks schedule for actual power consumption. FLA = Full load amperage. All motors are single phase/60 Hz.



For heat options; see page 2 and 3.
Dimensions are in inches (mm).

SCHEDULE TYPE:		DATE	B SERIES	SUPERSEDES	DRAWING NO.
PROJECT:		8 - 13 - 19	3700	7 - 18 - 17	37SST-2
ENGINEER:					
CONTRACTOR:					



**LOW PROFILE FAN POWERED TERMINAL UNIT WITH
EPIC ECM OR PSC MOTOR • HEAT ACCESSORIES
'STEALTH™' • SERIES FLOW
CONSTANT OR VARIABLE VOLUME
MODELS: 37SWST AND 37SEST • UNIT SIZE 4**

Hot Water Coil Section Model 37SWST

Standard Features:

- Coil section installed on unit discharge.
- Coil (and header on multi-circuit units) is installed in insulated casing for increased thermal efficiency.
- 1/2" (13) copper tubes.
- Aluminum ripple fins.
- Sweat connections: One row 1/2" (13) O.D. male solder. Two and three row 7/8" (22) O.D. male solder.
- Top and bottom access panels for inspection and coil cleaning.
- Flanged outlet duct connection.

Coil Rows:

- 1-Row 2-Row 3-Row

Coil Hand Connections:

(Looking in direction of airflow).

- Right hand (illustrated). Standard.
 Left hand. Optional.

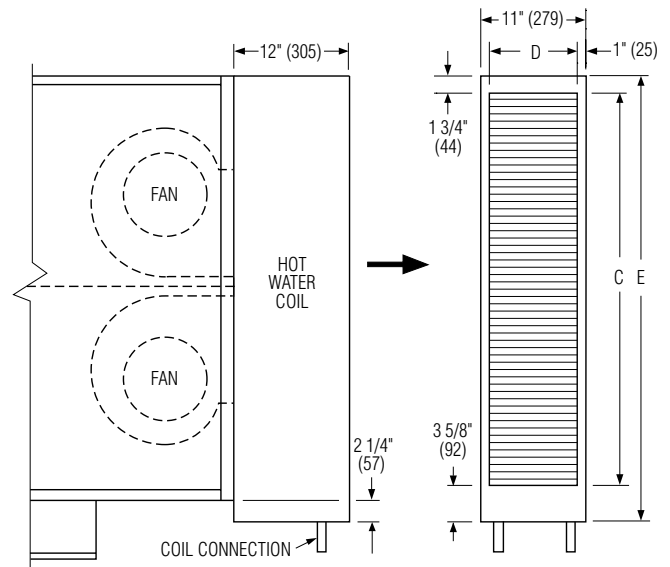

Unit Size	Outlet Duct Size C x D	E
4	41 x 9 (1041 x 229)	46 3/8 (1178)

**Hot Water Coil Section Model 37SWST
With FN2 Option**

Standard Features:

- Coil section installed on unit discharge.
- Coil and header are installed in insulated casing for increased thermal efficiency.
- 1/2" (13) copper tubes.
- Aluminum ripple fins.
- Sweat connections: One row 1/2" (13) O.D. male solder. Two and three row 7/8" (22) O.D. male solder.
- Top and bottom access panels for inspection and coil cleaning.
- Flanged outlet duct connection.

Coil Rows:

- 1-Row 2-Row 3-Row

Coil Hand Connection:

(Looking in direction of airflow).

- Left hand (illustrated). Standard.
 Right hand (terminals are inverted). Optional.
Connections must be selected opposite hand to FN2 controls enclosure location.

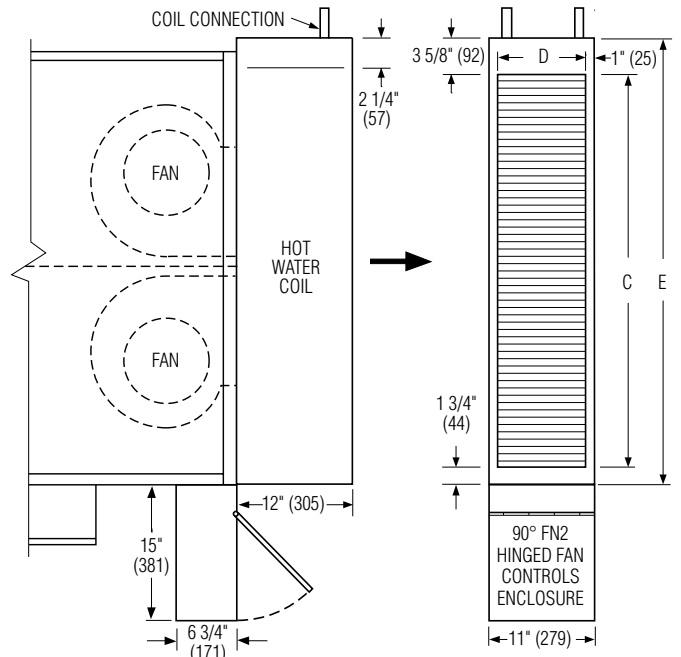

Unit Size	Outlet Duct Size C x D	E
4	41 x 9 (1041 x 229)	46 3/8 (1178)

SCHEDULE TYPE:	
PROJECT:	
ENGINEER:	
CONTRACTOR:	

Page 2 of 3.
Dimensions are in inches (mm).

DATE	B SERIES	SUPERSEDES	DRAWING NO.
8 - 13 - 19	3700	7 - 18 - 17	37SST-2



**LOW PROFILE FAN POWERED TERMINAL UNIT WITH
EPIC ECM OR PSC MOTOR • HEAT ACCESSORIES
'STEALTH™' • SERIES FLOW
CONSTANT OR VARIABLE VOLUME
MODELS: 37SWST AND 37SEST • UNIT SIZE 4**

Electric Coil Section Model 37SEST

Standard Features:

- Controls enclosure incorporates a hinged access door opening upstream that helps ensure NEC clearance requirements and reduces footprint. (FN2 90° design is standard).
- Unique hinged heater design permits easy access, removal and replacement of heater element without disturbing ductwork.
- Class A 80/20 Ni/Cr wire.
- Coil installed on unit discharge.
- Insulated coil element wrapper.
- Automatic reset high limit cut-outs (one per element).
- Single point electrical connection (except 600V).
- Fan interlock relay or positive pressure airflow switch.
- Flanged outlet duct connection.
- Terminal unit with coil is ETL Listed as an assembly.
- Controls mounted as standard on RH side as shown. Terminals ordered with LH controls (optional) are inverted.

Voltage:

Single phase, 60 Hz.

- 120V 208V 240V 277V

Three phase, 60 Hz.

- 208V 480V (4 wire wye).

- 600V (dual point connection). _____ .

Options:

- Toggle disconnect switch (includes fan).
- SCR control.
- Door interlock disconnect switch.
- Mercury contactors.
- Power circuit fusing.
- Dust tight construction.
- Manual reset secondary thermal cut out.

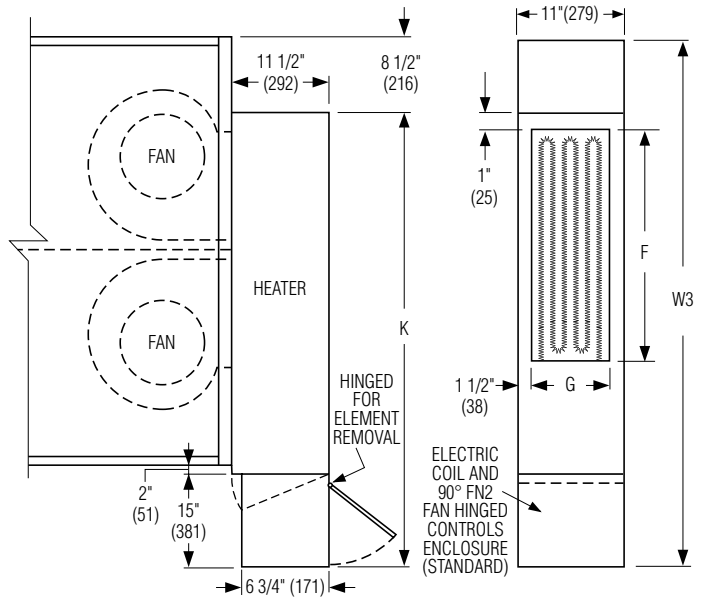

Unit Size	Outlet Duct Size F x G	W3	K
4	25 x 8 (635 x 203)	60 7/8 (1546)	52 3/8 (1330)

SCHEDULE TYPE:				
PROJECT:				
ENGINEER:	DATE	B SERIES	SUPERSEDES	DRAWING NO.
CONTRACTOR:	8 - 13 - 19	3700	7 - 18 - 17	37SST-2



FN3 REMOTE LINE VOLTAGE CONTROLS ENCLOSURE
FAN POWERED TERMINAL UNIT OPTION
MODEL SERIES: 33SZ, 35S(ST), 37S(ST), 38F AND 38S

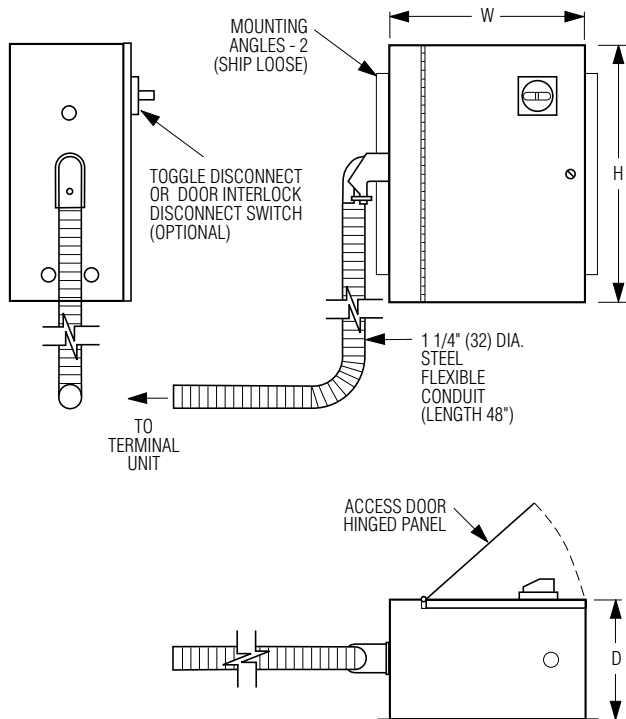

33SZ / 35S(ST) / 37S(ST) DESIGN
(Ceiling Mounted Terminal Unit)

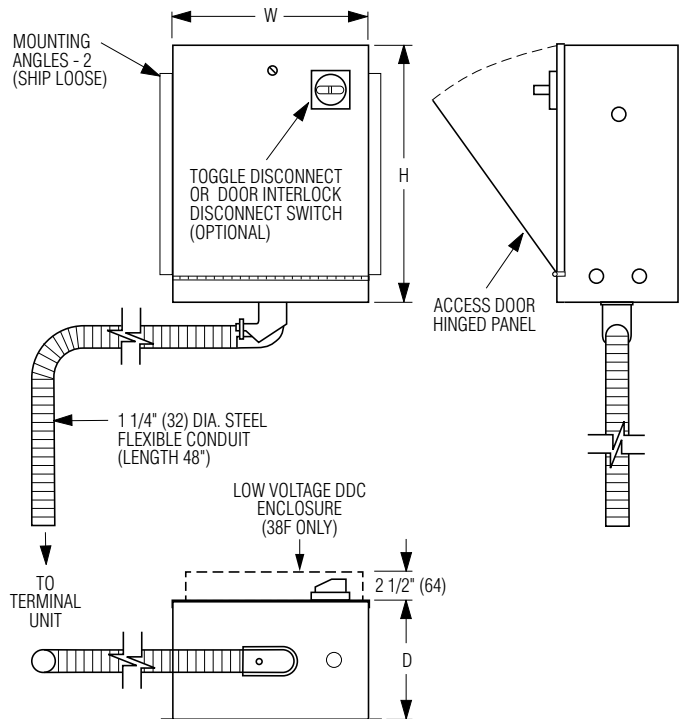

38F / 38S DESIGN
(Underfloor Terminal Unit)

Dimensional Data

Model Series	Unit Size	W	H	D
33SZ	10	15 (381)	8 1/2 (216)	6 3/4 (171)
	30, 35	15 (406)	11 (279)	6 3/4 (171)
	40, 50, 55	17 (432)	14 (356)	5 3/4 (146)
35S(ST)	1, 2	14 (356)	13 (330)	5 3/4 (146)
	3, 4, 5, 6, 7	14 (356)	17 (432)	5 3/4 (146)
37S(ST)	1, 2, 3, 4	15 (381)	11 (279)	6 3/4 (171)
38F	1, 3, 5, 6, 33, 3S, 3H, 6H, 33H	15 (381)	11 (279)	6 3/4 (171)
38S	1, 3, 5	15 (381)	11 (279)	6 3/4 (171)



NOTES:

- The FN3 line voltage enclosure is an ETL listed option. The FN3 was developed for Nailor fan powered terminal units in order to help meet NEC clearance requirements. Standard enclosures are mounted on the side of the unit and effectively add 42" (1067) to the terminals width footprint. Very often there is insufficient clearance in the ceiling plenum due to physical obstructions to accommodate this. The FN3 provides flexibility in that it may be field positioned in any orientation that provides the NEC clearance requirement.
- The FN3 Line voltage enclosure ships loose with a 48" (1219) flexible conduit connection to the terminal unit. The enclosure should be field mounted either on or remote from the terminal unit in a position that meets (NEC) clearance requirements.
 The controls enclosure is supplied with mounting angles, which ship loose for field attachment.

SCHEDULE TYPE:		Dimensions are in inches (mm)			
PROJECT:					
ENGINEER:	DATE	B SERIES	SUPERSEDES	DRAWING NO.	
CONTRACTOR:	1 - 12 - 22	FN	8 - 3 - 21	FN3	



**TERMINAL UNITS
LINER OPTIONS
TYPE: FIBERGLASS DUAL DENSITY INSULATION**

DESCRIPTION

Tuf-Skin® dual-density fiberglass insulation is the most widely-used insulation for HVAC equipment applications. The combination of high-density skin and low-density core provides high acoustical values in the high and low frequency ranges normally encountered in HVAC equipment.

Application. Tuf-Skin® provides effective thermal and acoustical control in air conditioning and heating equipment.

Advantage. The porosity and inherent structure of the flame-attenuated glass fiber blankets are highly effective in reducing thermal transfer.

Tuf-Skin® readily withstands damage from mechanical abrasion during assembly and from air erosion in service.

INSULATION CHARACTERISTICS

Material: Dual density fiberglass, surface treated to prevent erosion (Tuf-Skin® II)
 Available Thicknesses: 1/2" (13), 3/4" (19), 1" (25) (Consult individual model submittal for thickness used).
 Density: 4.0 lb/cu.ft. (64 kg/m³) skin, 1.5 lb/cu.ft. (24 kg/m³) core
 Thermal Conductance: 1/2" (13) - 0.52 BTU / hr-ft²-°F @ 75°F (2.95 W / m²-°C @ 24°C),
 3/4" (19) - 0.36 BTU / hr-ft²-°F @ 75°F (2.04 W / m²-°C @ 24°C),
 1" (25) - 0.26 BTU / hr-ft²-°F @ 75°F (1.47 W / m²-°C @ 24°C)
 Thermal Resistance: 1/2" (13) - 1.9 hr-ft²-°F / BTU (0.34 m²-°C / W),
 (Effective R-Value) 3/4" (19) - 2.8 hr-ft²-°F / BTU (0.49 m²-°C / W),
 1" (25) - 3.8 hr-ft²-°F / BTU (0.68 m²-°C / W)
 Flame Spread Index: 25
 Smoke Developed Index: 50

MAXIMUM AIR VELOCITY

3,600 FPM (1,097 mpm). Tested at two and one-half times (9,000 fpm) (2,743 mpm) the maximum recommended service velocity. Meets the erosion requirements of UL 181.

TEMPERATURE LIMIT

250°F (121°C).

STANDARD AND CODE COMPLIANCE

- ASTM E84, UL 723 and CAN/ULC S102 Flame/Smoke (25/50)
- NFPA 90A and 90B
- ASTM C 1071

Tuf-Skin® is a registered trademark of Johns Manville.

SCHEDULE TYPE:	Dimensions are in inches (mm)			
PROJECT:				
ENGINEER:	DATE	B SERIES	SUPERSEDES	DRAWING NO.
CONTRACTOR:	5 - 12 - 22	VAV.ACC.	3 - 30 - 22	VAV-FDD



**TERMINAL UNITS
LINER OPTIONS
SOUND POWER LEVEL CORRECTION FACTORS
TYPE: FIBER-FREE**

INSULATION CHARACTERISTICS

Material: Engineered Polymer Foam Insulation (EPFI). Closed cell. Zero permeability and water absorption.

Available Thicknesses: 1/2" (13), 3/4" (19), 1" (25) (Consult individual model submittal for thickness used).

Density: 1.5 lb/cu.ft. (24 kg/m³).

Thermal Conductivity: 0.27 BTU-in / hr-ft²-°F @ 75°F (0.039 W / m-°K @ 24°C). (K-Factor)

Thermal Resistance: 1/2" (13): 1.9 hr-ft²-°F / BTU (0.33 m²-°C / W). (R-Value) 3/4" (19): 2.8 hr-ft²-°F / BTU (0.49 m²-°C / W). 1" (25): 3.7 hr-ft²-°F / BTU (0.65 m²-°C / W).

Flame Spread Index: 25

Smoke Developed Index: 50

Mold Growth: None

Erosion: None

STANDARD AND CODE COMPLIANCE

- UL 181 Class I
- ASTM E84 and UL 723 Flame/Smoke (25/50)
- NFPA 90A (Heating and Cooling Equipment)
- ASTM C 209
- ASTM C 665

ACOUSTICAL PERFORMANCE

Correction factors to cataloged sound power level data (standard liner) are shown below.

Single Duct Terminal Units • 3000 Series Basic Unit • All sizes.

Octave Band	2	3	4	5	6	7	NC Impact
Center Frequency (Hz)	125	250	500	1000	2000	4000	(Average)
Discharge Sound	0	0	0	0	0	0	0
Radiated Sound	-1	-2	-2	-3	-3	-3	-2

Single Duct Terminal Units with Integral Attenuator • 3000 Series • All Sizes.

Octave Band	2	3	4	5	6	7	NC Impact
Center Frequency (Hz)	125	250	500	1000	2000	4000	(Average)
Discharge Sound	+1	+1	+3	+4	+7	+8	+3
Radiated Sound	-1	-2	-2	-3	-3	-3	-2

Fan Powered Terminal Units • 33SZ, 35N, 35S, 37N and 37S Series • All sizes.

Octave Band	2	3	4	5	6	7	NC Impact
Center Frequency (Hz)	125	250	500	1000	2000	4000	(Average)
Discharge Sound	0	0	0	0	0	0	0
Radiated Sound	+2	+2	+4	+2	+2	+2	+3

Fan Powered Terminal Units • 35SST and 37SST "Stealth" Series • All sizes.

Octave Band	2	3	4	5	6	7	NC Impact
Center Frequency (Hz)	125	250	500	1000	2000	4000	(Average)
Discharge Sound	0	0	0	0	0	0	0
Radiated Sound	+2	+2	+4	+2	+2	+2	+3

SCHEDULE TYPE:	Dimensions are in inches (mm)			
PROJECT:				
ENGINEER:	DATE	B SERIES	SUPERSEDES	DRAWING NO.
CONTRACTOR:	5 - 12 - 22	VAV.ACC.	4 - 17 - 20	VAV-FF



**TERMINAL UNITS
LINER OPTIONS
SOUND POWER LEVEL CORRECTION FACTORS
TYPE: STERI-LINER**

INSULATION CHARACTERISTICS

Material: Rigid board form fiberglass with a thermosetting resin. Fire resistant reinforced aluminum foil-scrim-kraft (FSK) facing.

Available Thicknesses: 1/2" (13), 13/16" (21), 1" (25) (Consult individual model submittal for thickness used).

Density: 4.1 lb/cu.ft. (66 kg/m³).

Thermal Conductivity: 0.23 BTU-in / hr-ft²-°F @ 75°F (0.033 W / m-°K @ 24°C).
(K-Factor)

Thermal Resistance: 1/2" (13) - 2.2 hr-ft²-°F / BTU (0.48 m²-°C / W).
(R-Value) 13/16" (21) - 3.5 hr-ft²-°F / BTU (0.76 m²-°C / W).
1" (25) - 4.3 hr-ft²-°F / BTU (0.96 m²-°C / W).

Flame Spread Index: 25

Smoke Developed Index: 50

Mold Growth: None

STANDARD AND CODE COMPLIANCE

- UL 181 Class I
- ASTM E84 and UL 723 Flame/Smoke (25/50)
- NFPA 90A and 90B
- ASTM C 1071 Air Velocity (2000 fpm max.)
- ASTM C 665
- ASTM C 1338, G21 and G22 Fungi and Bacteria Resistance

ACOUSTICAL PERFORMANCE

Correction factors to cataloged sound power level data (standard liner) are shown below.

Single Duct Terminal Units • 3000 Series Basic Unit • All sizes.

Octave Band	2	3	4	5	6	7	NC Impact
Center Frequency (Hz)	125	250	500	1000	2000	4000	(Average)
Discharge Sound	0	0	0	0	0	0	0
Radiated Sound	-1	-2	-2	-3	-3	-3	-2

Single Duct Terminal Units with Integral Attenuator • 3000 Series • All Sizes.

Octave Band	2	3	4	5	6	7	NC Impact
Center Frequency (Hz)	125	250	500	1000	2000	4000	(Average)
Discharge Sound	+1	+1	+3	+4	+7	+8	+3
Radiated Sound	-1	-2	-2	-3	-3	-3	-2

Fan Powered Terminal Units • 33SZ, 35N, 35S, 37N and 37S Series • All sizes.

Octave Band	2	3	4	5	6	7	NC Impact
Center Frequency (Hz)	125	250	500	1000	2000	4000	(Average)
Discharge Sound	0	0	0	0	0	0	0
Radiated Sound	+2	+3	+6	+11	+10	+3	+3

Fan Powered Terminal Units • 35SST and 37SST "Stealth" Series • All sizes.

Octave Band	2	3	4	5	6	7	NC Impact
Center Frequency (Hz)	125	250	500	1000	2000	4000	(Average)
Discharge Sound	0	0	0	0	0	0	0
Radiated Sound	-5	-4	-4	0	+3	+5	-4

SCHEDULE TYPE:	Dimensions are in inches (mm)			
PROJECT:				
ENGINEER:	DATE	B SERIES	SUPERSEDES	DRAWING NO.
CONTRACTOR:	5 - 17 - 22	VAV.ACC.	1 - 12 - 21	VAV-SL



**VAV TERMINAL UNITS
LINER OPTIONS
TYPE: SOLID METAL LINER
(DOUBLE WALL CONSTRUCTION)**

A Solid metal liner completely isolates the standard insulation and its raw edges from the airstream within the terminal. The solid metal liner option, also referred to as double wall construction, offers excellent protection against exposure of fiberglass particles to the airstream. This option is ideal for applications where Indoor Air Quality (IAQ) is a concern and where terminals will be wiped down and cleaned on a regular basis. This option is also resistant to moisture.

ISOLATED INSULATION

Material: Dual Density flame attenuated glass fiber.
 Thickness: 3/4" (19). (37N, 37S, 37SST and 33SZ Size 30 Low Profile Fan Powered Terminal Units use 1/2" (13) material).
 Density: 4.0 lb/cu. ft. (64 kg/m³) skin.
 1.5 lb/cu. ft. (24 kg/m³) core.
 Thermal Conductance: 0.36 BTU / hr-ft²-°F @ 75°F (2.04 W / m²-°C @ 24°C).
 (C) For 1/2" (13) material: 0.52 BTU / hr-ft²-°F @ 75°F (2.95 W / m²-°C @ 24°C).

STANDARD AND CODE COMPLIANCE

- UL 181 Class I
- ASTM E84 and UL 723 Flame/Smoke (25/50)
- NFPA 90A and 90B
- ASTM C 1071 Air Velocity (2000 fpm max.)
- ASTM C 665

ACOUSTICAL PERFORMANCE

Correction factors to cataloged sound power level data (standard dual density insulation) are shown below.

Single Duct Terminal Units • 3000 Series Basic Unit • All sizes.

Octave Band	2	3	4	5	6	7	NC Impact
Center Frequency (Hz)	125	250	500	1000	2000	4000	(Average)
Discharge Sound	0	0	0	0	0	0	0
Radiated Sound	-1	-2	-2	-3	-3	-3	-2

Fan Powered Terminal Units • 33SZ, 35N, 35S, 37N and 37S Series • All sizes.

Octave Band	2	3	4	5	6	7	NC Impact
Center Frequency (Hz)	125	250	500	1000	2000	4000	(Average)
Discharge Sound	0	0	0	0	0	0	0
Radiated Sound	+2	+1	+2	+6	+13	+14	+3

Fan Powered Terminal Units • 35SST and 37SST "Stealth" Series • All sizes.

Octave Band	2	3	4	5	6	7	NC Impact
Center Frequency (Hz)	125	250	500	1000	2000	4000	(Average)
Discharge Sound	0	0	0	0	0	0	0
Radiated Sound	-5	-4	-4	0	+3	+5	-4

Dual Duct Terminal Units • 3230 and 3240 "Blendmaster" Series • All sizes.

Nailor has independently tested and cataloged their dual duct sound data based upon the use of Steri-Liner (high density foil back insulation) rather than standard dual density fiberglass insulation as used in the above terminal units. This is because it is the most popular specification for dual duct terminals, where IAQ is frequently a concern. Solid metal liner is acoustically reflective in a manner similar to Steri-Liner. The cataloged data may therefore be used without correction when a solid metal liner is required.

SCHEDULE TYPE				
PROJECT				
ENGINEER	DATE	B SERIES	SUPERSEDES	DRAWING NO.
CONTRACTOR	8 - 19 - 16	VAV.ACC.	11 - 19 - 12	VAV - SML

Recommended Primary Valve Airflow Ranges For All Fan Powered Terminal Units

The recommended airflow ranges below are for fan powered terminal units with pressure independent controls and are presented as ranges for total and controller specific minimum and maximum airflow. Airflow ranges are based upon maintaining reasonable sound levels and controller limits using Nailor's Diamond Flow Sensor as the airflow measuring device. For a given unit size, the minimum, auxiliary and the maximum flow setting must be within the range limits to ensure pressure independent operation, accuracy and repeatability.

Minimum airflow limits are based upon .02" w.g. (5 Pa) differential pressure signal from Diamond Flow Sensor on analog/digital controls and .03" (7.5) for pneumatic controllers. This is a realistic low limit for many transducers used in the digital controls industry. Check your controls supplier for minimum limits. Setting airflow minimums lower, may cause hunting and failure to meet minimum ventilation requirements.

The high end of the tabulated Total Airflow Range on pneumatic and analog electronic controls represents the Diamond Flow Sensor's differential pressure reading at 1" w.g. (249 Pa). The high end airflow range for digital controls is represented by the indicated transducer differential pressure.

ASHRAE 130 "Performance Rating of Air Terminals" is the method of test for the certification program. The "standard rating condition" (certification rating point) airflow volumes for each terminal unit size are tabulated below per AHRI Standard 880. These air volumes equate to an approximate inlet velocity of 2000 fpm (10.2 m/s).

When digital or other controls are mounted by Nailor, but supplied by others, these values are guidelines only, based upon experience with the majority of controls currently available. Controls supplied by others for factory mounting are configured and calibrated in the field. Airflow settings on pneumatic and analog controls supplied by Nailor are factory preset when provided.

Imperial Units, Cubic Feet per Minute

Inlet Size	Inlet Type	Total Airflow Range, cfm	Airflow at 2000 fpm Inlet Velocity (nom.), cfm	Range of Minimum and Maximum Settings, cfm								
				Pneumatic 3000 Controller		Analog Electronic Controls		Digital Controls				
				Transducer Differential Pressure (w.g.)								
				Min.	Max.	Min.	Max.	Min.	Max.			
.03	1.0	.02	1.0	.02	1.0	1.25	≥ 1.5					
4	Round	0 – 225	150	30	180	25	180	25	180	200	225	
5		0 – 400	250	55	325	45	325	45	325	360	400	
6		0 – 550	400	80	450	65	450	65	450	500	550	
7		0 – 800	550	115	650	95	650	95	650	725	800	
8		0 – 1100	700	155	900	125	900	125	900	1000	1100	
9		0 – 1400	900	200	1150	165	1150	165	1150	1285	1400	
10		0 – 1840	1100	260	1500	215	1500	215	1500	1675	1840	
12		0 – 2500	1600	355	2050	290	2050	290	2050	2290	2500	
14		0 – 3370	2100	475	2750	390	2750	390	2750	3075	3370	
16		0 – 4510	2800	640	3700	520	3700	520	3700	4120	4510	
12		Flat Oval	0 – 2500	1600	355	2050	290	2050	290	2050	2300	2500
14			0 – 3125	2100	440	2550	360	2550	360	2550	2850	3125
16			0 – 3725	2800	525	3040	430	3040	430	3040	3400	3725
18			0 – 5265	3500	750	4300	610	4300	610	4300	4800	5265
14 x 8		Rect.	0 – 2450	1560	350	2000	290	2000	290	2000	2240	2450
14 x 10			0 – 2950	1900	420	2400	340	2400	340	2400	2700	2950

Metric Units, Liters per Second

Inlet Size	Inlet Type	Total Airflow Range, l/s	Airflow at 10.2 m/s Inlet Velocity (nom.), l/s	Range of Minimum and Maximum Settings, l/s								
				Pneumatic 3000 Controller		Analog Electronic Controls		Digital Controls				
				Transducer Differential Pressure (Pa)								
				Min.	Max.	Min.	Max.	Min.	Max.			
7.5	249	5	249	5	249	311	≥ 374					
4	Round	0 – 106	71	14	85	12	85	12	85	94	106	
5		0 – 189	118	26	153	21	153	21	153	170	189	
6		0 – 260	189	38	212	31	212	31	212	236	260	
7		0 – 378	260	54	307	45	307	45	307	342	378	
8		0 – 519	330	73	425	59	425	59	425	472	519	
9		0 – 661	425	94	543	78	543	78	543	606	661	
10		0 – 868	519	123	708	101	708	101	708	790	868	
12		0 – 1180	755	168	967	137	967	137	967	1081	1180	
14		0 – 1590	991	224	1298	184	1298	184	1298	1451	1590	
16		0 – 2128	1321	302	1746	245	1746	245	1746	1944	2128	
12		Flat Oval	0 – 1180	755	168	967	137	967	137	967	1085	1180
14			0 – 1475	991	208	1203	170	1203	170	1203	1345	1475
16			0 – 1758	1321	248	1435	203	1435	203	1435	1604	1758
18			0 – 2485	1652	354	2029	288	2029	288	2029	2265	2485
14 x 8		Rect.	0 – 1156	736	165	944	137	944	137	944	1057	1156
14 x 10			0 – 1392	897	198	1133	160	1133	160	1133	1274	1392

Performance Data Explanation

Sound Power Levels vs. NC Levels

The **Nailor Model Series: 35S, 35SST, 37S, 37SST, 35N and 37N** fan powered terminal unit performance data is presented in two forms.

The laboratory obtained discharge and radiated sound power levels in octave bands 2 through 7 (125 through 4000 Hz) center frequency for each unit size at various flow rates and inlet static pressures is presented. This data is derived in accordance with ANSI/ASHRAE Standard 130 and AHRI Standard 880. This data is raw with no attenuation deductions and includes AHRI Certification standard rating points.

Nailor also provides an "NC Level" table as an application aid in terminal selection, which include attenuation allowances as explained below. The suggested attenuation allowances are typical and are not representative of specific job site conditions. It is recommended that the sound power level data be used and a detailed NC calculation be performed using the procedures outlined in AHRI Standard 885, Appendix E for accurate space sound levels.

Explanation of NC Levels

Tabulated NC levels are based on attenuation values as outlined in AHRI Standard 885 Procedure for Estimating Occupied Space Sound Levels in the Application of Air Terminals and Air Outlets". AHRI Standard 885, Appendix E provides typical sound attenuation values for air terminal discharge sound and air terminal radiated sound.

As stated in AHRI Standard 885, Appendix E, These values can be used as a quick method of estimating space sound levels when a detailed evaluation is not available. The attenuation values are required for use by manufacturers to catalog application sound levels. In product catalogs, the end user environments are not known and the following factors are provided as typical attenuation values. Use of these values will allow better comparison between manufacturers and give the end user a value which will be expected to be applicable for many types of space.

Radiated Sound

Table E1 of Appendix E provides typical radiated sound attenuation values for three types of ceiling: Type 1 – Glass Fiber; Type 2 – Mineral Fiber; Type 3 – Solid Gypsum Board.

Since Mineral Fiber tile ceilings are the most common construction used in commercial buildings, these values have been used to tabulate Radiated NC levels.

The following table provides the calculation method for the radiated sound total attenuation values based on AHRI Standard 885.

	Octave Band					
	2	3	4	5	6	7
Environmental Effect	2	1	0	0	0	0
Ceiling/Space Effect	16	18	20	26	31	36
Total Attenuation Deduction	18	19	20	26	31	36

The ceiling/space effect assumes the following conditions:

1. 5/8" (16) tile, 20 lb/ft³ (320 kg/m³) density.
2. The plenum is at least 3 feet (914) deep.
3. The plenum space is either wide [over 30 feet (9 m)] or lined with insulation.
4. The ceiling has no significant penetration directly under the unit.

Discharge Sound

Table E1 of Appendix E provides typical discharge sound attenuation values for three sizes of terminal unit.

1. Small box; Less than 300 cfm (142 l/s)
[Discharge Duct 8" x 8" (203 x 203)].
2. Medium box; 300 – 700 cfm (142 - 330 l/s)
[Discharge Duct 12" x 12" (305 x 305)].
3. Large box; Greater than 700 cfm (330 l/s)
[Discharge Duct 15" x 15" (381 x 381)].

These attenuation values have been used to tabulate Discharge NC levels applied against the terminal airflow volume and not terminal unit size.

The following tables provide the calculation method for the discharge sound total attenuation values based on AHRI Standard 885.

Small Box <300 cfm	Octave Band					
	2	3	4	5	6	7
Environmental Effect	2	1	0	0	0	0
5 ft. (1.5 m) 1" (25) Duct Lining	2	6	12	25	29	18
Branch Power Division (1 outlet)	0	0	0	0	0	0
5 ft. (1.5 m), 8 in. dia. (203) Flex Duct	5	10	18	19	21	12
End Reflection	10	5	2	1	0	0
Space Effect	5	6	7	8	9	10
Total Attenuation Deduction	24	28	39	53	59	40

Medium Box 300 – 700 cfm	Octave Band					
	2	3	4	5	6	7
Environmental Effect	2	1	0	0	0	0
5 ft. (1.5 m) 1" (25) Duct Lining	2	4	10	20	20	14
Branch Power Division (2 outlets)	3	3	3	3	3	3
5 ft. (1.5 m), 8 in. dia. (203) Flex Duct	5	10	18	19	21	12
End Reflection	10	5	2	1	0	0
Space Effect	5	6	7	8	9	10
Total Attenuation Deduction	27	29	40	51	53	39

Large Box >700 cfm	Octave Band					
	2	3	4	5	6	7
Environmental Effect	2	1	0	0	0	0
5 ft. (1.5 m) 1" (25) Duct Lining	2	3	9	18	17	12
Branch Power Division (3 outlets)	5	5	5	5	5	5
5 ft. (1.5 m), 8 in. dia. (203) Flex Duct	5	10	18	19	21	12
End Reflection	10	5	2	1	0	0
Space Effect	5	6	7	8	9	10
Total Attenuation Deduction	29	30	41	51	52	39

1. Flexible duct is non-metallic with 1" (25) insulation.
2. Space effect (room size and receiver location) 2500 ft.³ (69 m³) and 5 ft. (1.5 m) distance from source.

For a complete explanation of the attenuation factors and the procedures for calculating room NC levels, please refer to the acoustical engineering guidelines at the back of this catalog and AHRI Standard 885.

Performance Data

ECM Motor Fan Curves – Airflow vs. Downstream Static Pressure

37S Series • Low Profile • Series Flow

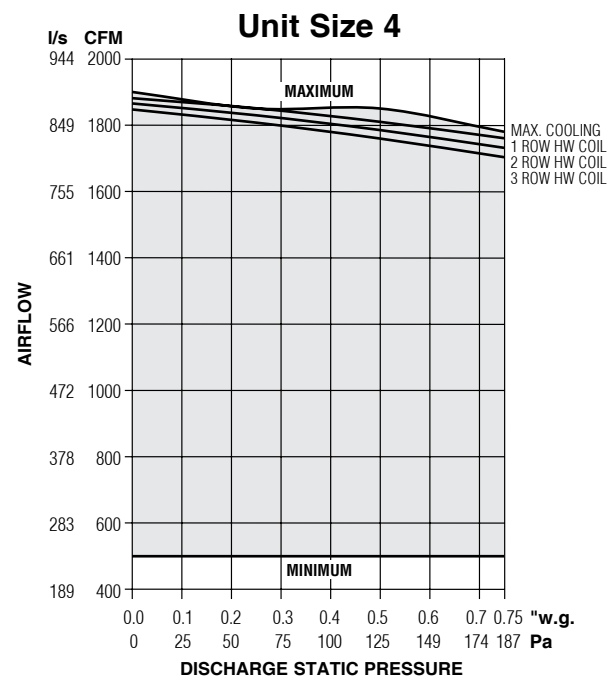
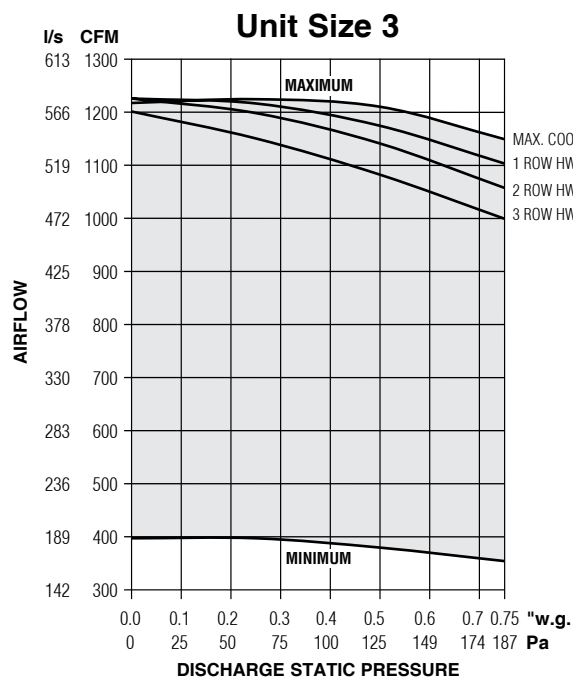
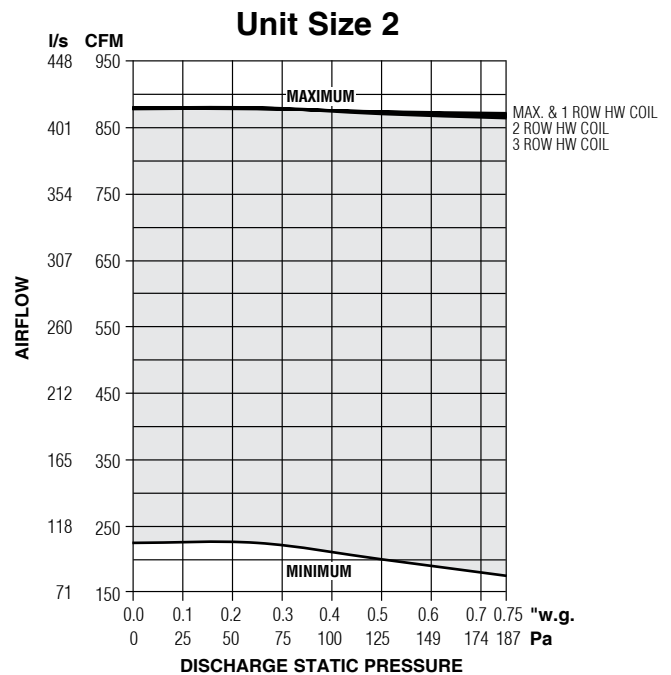
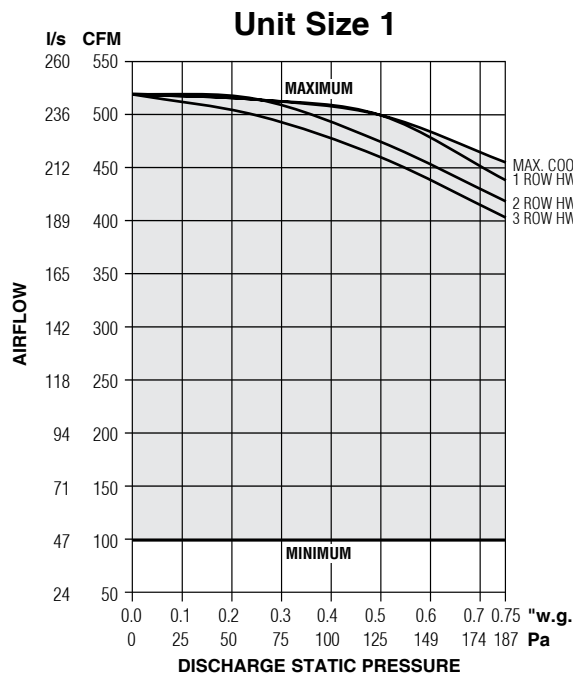

Electrical Data

Unit Size	EPIC ECM Motor FLA				
	Motor HP	120V	208V	240V	277V
1	*	1.9	1.3	1.3	1.3
2	*	3.3	2.2	2.2	2.2
3	*	6.9	4.7	4.4	4.4
4	*	8.0	5.4	5.2	4.9

* The EPIC ECM is a variable horsepower motor. Refer to Selectworks schedule for actual power consumption. FLA = Full load amperage. All motors are single phase/60 Hz.

NOTES:

- The ECM is pressure independent and constant volume in operation at factory or field set point within the shaded area. Airflow does not vary with changing static pressure conditions. The motor compensates for any changes in external static pressure or induced air conditions such as filter loading.
- Airflow can be set to operate on horizontal performance line at any point within shaded area using the solid state volume controller provided.
- Fan curves shown are applicable to 120, 208, 240 and 277 volt, single phase ECM's. ECM's, although DC in operation, include a built-in inverter.



Performance Data

PSC Motor Fan Curves – Airflow vs. Downstream Static Pressure

37S Series • Low Profile • Series Flow

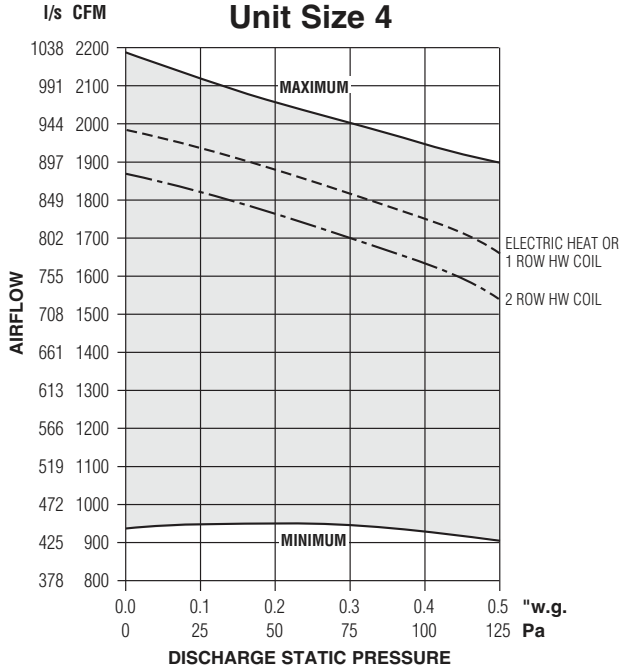
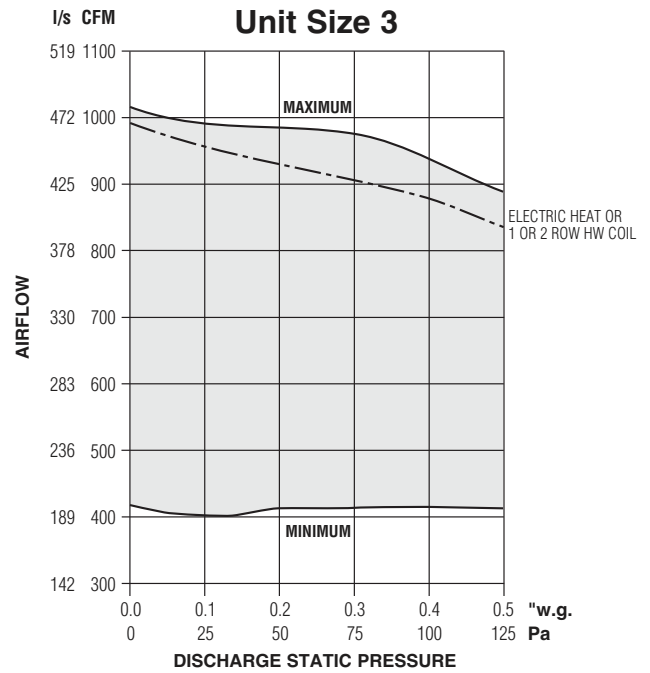
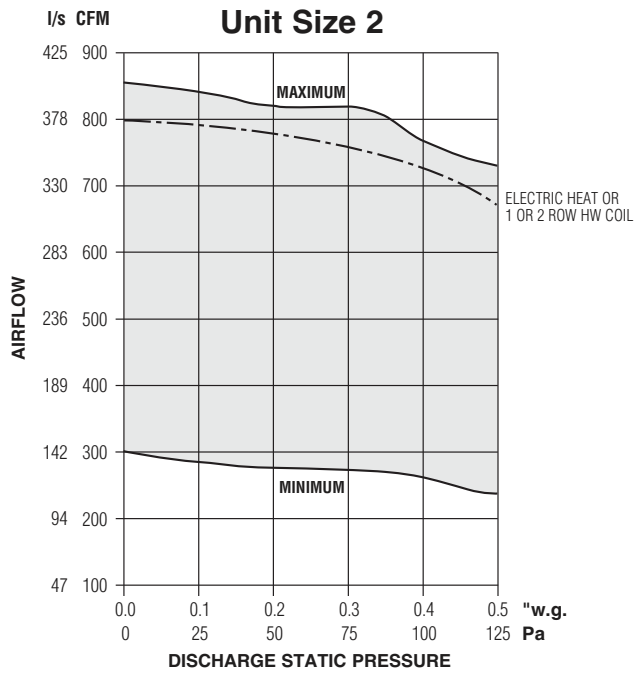

- Fan Curves shown are applicable to 120, 208, 240 and 277 volt, single phase PSC motors.

Electrical Data

Unit Size	PSC Motor HP	PSC Motor FLA			
		120V	208V	240V	277V
2	1/6	4.8	1.8	1.8	1.5
3	1/4	5.3	3.6	3.6	1.8
4	2@1/4	10.6	7.2	7.2	3.7

FLA = Full load amperage.
All motors are single phase/60 Hz.

Performance Data • AHRI Certification and Performance Notes

Model Series 37S • Low Profile • Series Flow • Basic Unit • AHRI Certification Rating Points Fiberglass Liner

Unit Size	Inlet Size	Fan Airflow		Fan ^Σ Watts	Fan Only* @ .25" w.g. (62 Pa) ΔPs														Primary Airflow		Min. Inlet ΔPs		Fan + 100% Primary @ 1.5" w.g. (375 Pa) ΔPs w/ .25" w.g. (62 Pa) Discharge ΔPs						
					Discharge							Radiated											Radiated						
					2	3	4	5	6	7	2	3	4	5	6	7	2	3					4	5	6	7			
1	8	400	189	140	73	68	63	60	57	54	65	59	54	52	44	37	400	189	0.02	4	64	60	53	52	52	52			
2	10	800	378	170	71	69	66	63	60	58	67	60	56	56	48	40	800	378	0.03	7	66	62	57	58	54	57			
3	10	1100	519	400	78	75	70	70	68	65	70	63	59	59	52	44	1100	519	0.05	12	72	66	61	61	55	58			
4	14 x 10	1800	849	600	77	73	72	72	70	67	74	67	64	61	52	44	1800	849	0.12	30	74	70	67	64	59	58			

^Σ Motor = ECM.

* Primary air valve is closed and therefore primary cfm is zero.



Ratings are certified in accordance with AHRI Standards.

Performance Notes for Sound Power Levels:

- Discharge (external) static pressure is 0.25" w.g. (63 Pa) in all cases, which is the difference (ΔPs) in static pressure from terminal discharge to the room.
Discharge Sound Power Levels (SWL) now include duct end reflection energy as part of the standard rating. Including the duct end correction provides sound power levels that would normally be transmitted into an acoustically, non-reflective duct. The effect of including the energy correction to the discharge SWL, is higher sound power levels when compared to previous AHRI certified data. For more information on duct end reflection calculations see AHRI Standard 880.
- Radiated sound power is the breakout noise transmitted through the unit casing walls.
- Sound power levels are in decibels, dB re 10⁻¹² watts.

- All sound data listed by octave bands is raw data without any corrections for room absorption or duct attenuation. Dash (-) in space indicates sound power level is less than 20 dB or equal to background.
- Min. inlet ΔPs is the minimum operating pressure of the primary air valve section.
- Asterisk (*) in space indicates that the minimum inlet static pressure requirement is greater than 0.5" w.g. (125 Pa) at rated airflow.
- Data derived from independent tests conducted in accordance with ANSI / ASHRAE Standard 130 and AHRI Standard 880.



Performance Data • Discharge Sound Power Levels

Model Series 37S • Low Profile • Series Flow • Basic Unit

Fiberglass Liner



Unit Size	Inlet Size	Airflow		Min. inlet ΔPs		Fan Only		Fan and 100% Primary Air – Sound Power Octave Bands @ Inlet pressure (ΔPs) shown																																	
								Minimum ΔPs					0.5" w.g. (125Pa) ΔPs					1.0" w.g. (249Pa) ΔPs					1.5" w.g. (375Pa) ΔPs					2.0" w.g. (500Pa) ΔPs													
		cfm	l/s	"w.g.	Pa	2	3	4	5	6	7	2	3	4	5	6	7	2	3	4	5	6	7	2	3	4	5	6	7	2	3	4	5	6	7						
1	6	400	189	0.15	37	73	68	63	60	57	54	69	63	58	51	47	45	72	66	60	54	51	48	71	65	57	50	46	43	73	68	60	54	51	47	74	70	63	55	52	48
		300	142	0.07	17	69	63	58	54	50	46	65	57	52	44	39	36	69	61	55	49	44	39	69	61	52	44	38	34	69	64	56	47	41	36	70	66	59	49	43	38
		200	94	0.02	5	62	54	50	44	38	30	64	52	44	36	30	25	66	54	45	36	29	23	66	58	48	36	26	21	66	59	52	37	27	21	66	60	54	39	29	23
		100	47	0.01	1	56	48	44	37	29	-	60	46	37	29	22	-	62	49	37	28	-	-	63	55	43	28	-	-	61	55	47	29	-	-	62	55	50	32	-	-
	8	400	189	0.02	4	73	68	63	60	57	54	69	63	57	51	47	45	71	65	60	54	51	48	71	64	57	50	46	43	72	68	60	54	51	47	73	69	62	55	52	48
		300	142	0.01	2	69	63	58	54	50	46	64	56	51	44	39	36	68	61	55	48	44	39	67	60	52	44	38	34	68	63	55	46	41	36	69	65	58	48	43	38
		200	94	0.01	2	62	54	50	44	38	30	62	51	43	36	30	25	64	53	44	36	29	23	64	57	47	35	26	21	64	58	51	37	27	21	64	59	53	39	29	23
		100	47	0.01	2	56	48	44	37	29	-	58	45	37	29	22	-	61	47	36	28	-	-	61	54	43	28	-	-	60	54	46	28	-	-	60	53	49	31	-	-
2	6	550	260	0.21	52	63	61	58	56	52	47	65	60	58	54	49	43	63	58	57	52	47	41	66	60	58	53	48	41	67	62	58	53	48	41	69	62	59	53	48	41
		400	189	0.08	20	59	56	54	51	47	39	62	57	56	51	45	36	62	56	55	49	43	34	63	58	55	49	43	34	65	59	56	49	43	34	65	59	56	49	43	34
		275	130	0.01	2	56	51	50	46	40	30	61	53	51	46	40	29	60	53	50	44	37	26	60	54	51	44	37	24	63	56	52	44	37	25	62	56	52	44	37	26
	8	800	378	0.11	27	71	69	66	63	60	58	68	66	62	58	55	51	67	65	61	57	53	50	68	64	61	57	53	49	70	66	61	57	53	50	70	66	62	58	54	50
		700	330	0.08	19	67	65	62	60	56	53	67	64	61	57	53	48	66	62	59	55	51	47	67	63	60	56	51	47	69	64	60	56	51	47	71	65	61	56	52	47
		550	260	0.04	10	63	61	58	56	52	47	64	60	58	54	49	43	62	58	56	52	47	41	64	60	57	53	48	41	66	61	58	53	48	41	68	62	58	53	48	41
		400	189	0.02	4	59	56	54	51	47	39	60	55	55	50	45	36	60	55	54	49	43	34	61	56	54	49	43	34	63	58	55	48	43	34	63	58	55	49	43	34
		275	130	0.01	2	56	51	50	46	40	30	59	52	50	45	39	28	58	52	49	44	37	25	58	53	50	43	36	24	62	54	51	43	36	25	60	54	51	44	36	25
	10	800	378	0.03	7	71	69	66	63	60	58	68	66	61	58	55	51	67	64	60	57	53	50	67	64	60	57	53	49	69	65	61	57	53	50	70	66	61	58	54	50
		700	330	0.02	4	67	65	62	60	56	53	66	63	60	57	53	48	65	61	59	55	51	47	66	62	59	55	51	47	68	64	60	56	51	47	69	64	60	56	52	47
		550	260	0.01	2	63	61	58	56	52	47	62	59	57	53	49	43	61	57	56	51	47	41	63	59	57	52	48	41	65	61	57	52	48	41	67	61	57	52	48	41
		400	189	0.01	2	59	56	54	51	47	39	59	54	54	50	45	36	58	54	53	48	43	34	60	55	53	48	43	34	61	56	54	48	43	34	61	57	54	48	43	34
275		130	0.01	2	56	51	50	46	40	30	57	50	49	45	39	28	56	50	48	43	37	25	56	51	49	43	36	24	60	52	50	43	36	24	58	52	50	43	36	25	
3	6	550	260	0.22	55	69	63	60	59	55	51	71	65	61	58	53	49	73	66	62	59	54	50	74	67	62	59	54	50	76	68	63	59	55	50	76	68	63	59	55	50
		400	189	0.09	22	62	57	55	52	47	42	64	59	57	52	48	42	63	59	56	52	47	41	66	61	56	52	47	41	69	63	57	52	48	42	70	63	58	52	48	42
	8	1100	519	0.15	37	78	75	70	70	68	65	78	75	69	68	66	63	78	75	69	68	66	63	79	76	70	68	66	63	80	75	70	68	66	63	80	76	70	68	66	63
		900	425	0.09	22	75	72	68	67	64	61	76	72	67	66	63	60	76	72	66	66	63	60	77	73	67	66	63	60	79	73	67	66	63	60	79	73	68	66	63	60
		650	307	0.04	10	69	63	60	59	55	51	69	64	60	58	53	49	71	65	61	58	54	50	72	65	61	58	54	50	73	67	61	58	55	50	74	67	62	59	55	50
		400	189	0.01	2	62	57	55	52	47	42	62	58	56	52	47	41	62	58	55	51	47	40	64	59	55	51	47	40	67	61	56	51	47	41	68	62	57	52	48	42
	10	1150	543	0.05	12	78	76	71	70	68	65	77	75	69	68	66	64	78	75	69	68	66	63	78	75	69	68	66	63	79	75	70	68	66	63	79	75	70	68	66	63
		1100	519	0.05	12	78	75	70	70	68	65	77	75	69	68	66	63	77	74	68	68	66	63	78	75	69	68	66	63	79	75	69	68	66	63	79	75	69	68	66	63
		900	425	0.04	9	75	72	68	67	64	61	74	72	66	65	63	60	75	71	66	65	63	60	76	72	66	65	63	60	77	72	67	65	63	60	77	73	67	65	63	60
		650	307	0.02	4	69	63	60	59	55	51	67	63	59	57	53	49	69	63	59	57	54	50	70	64	60	57	54	50	71	65	60	58	55	50	72	66	61	58	55	50
400	189	0.01	1	62	57	55	52	47	42	60	56	54	51	47	41	60	56	54	51	46	40	62	57	54	51	46	40	65	59	55	51	47	41	66	60	56	51	47	41		
4	10	1950	920	0.20	50	79	74	73	74	71	69	77	74	73	72	70	67	77	74	73	73	71	68	79	76	75	74	72	69	80	77	76	75	72	70	81	78	76	75	73	70
		1800	849	0.17	42	77	73	72	72	70	67	76	72	71	71	68	66	76	73	72	72	69	67	78	75	73	73	70	68	79	76	75	73	71	69	80	77	75	74	71	69
		1450	684	0.12	29	73	68	68	68	65	62	73	68	68	68	64	61	74	69	69	69	65	62	76	72	70	70	66	64	77	73	72	71	67	64	77	74	72	71	68	65
		1100	519	0.08	19	67	63	64	62	59	55	67	63	64	62	58	55	71	66	66	65	61	57	73	69	68	66	62	59	74	70	69	67	63	60	74	70	69	67	63	60
	800	378	0.05	11	62	57	59	57	54	48	62	57	60	57	53	47	65	60	61	59	55	49	66	62	62	60	56	51	68	63	63	61	56	51	68	63	63	61	57	52	
	14 x 10	1950	920	0.13	32	79	74	73	74	71	69	76	73	72	72	70	67	77	73	73	73	71	68	78	75	74	74	72	69	80	76	75	75	72	70	80	77	76	75	73	70
		1800	849	0.12	30	77	73	72	72	70	67	75	72	71	71	68	66	76	72	72	72	69	67	77	74	73	73	70	68	78	75	74	73	71	69	79	76	74	74	71	69
		1450	684																																						

Performance Data • NC Level Application Guide

Model Series 37S • Low Profile • Series Flow

Fiberglass Liner

Unit Size	Inlet Size	Airflow		Min. inlet ΔPs		NC Levels @ Inlet Pressure (ΔPs) shown											
						DISCHARGE					RADIATED						
						Fan Only	Min. ΔPs	0.5" w.g. (125 Pa)	1.0" w.g. (250 Pa)	1.5" w.g. (375 Pa)	2.0" w.g. (500 Pa)	Fan Only	Min. ΔPs	0.5" w.g. (125 Pa)	1.0" w.g. (250 Pa)	1.5" w.g. (375 Pa)	2.0" w.g. (500 Pa)
1	6	400	189	0.15	37	28	23	26	25	28	30	29	25	26	28	30	31
		300	142	0.07	17	23	-	23	23	23	25	20	23	23	24	26	28
		200	94	0.02	5	-	20	23	23	23	23	-	-	-	-	21	22
		100	47	0.01	1	-	-	-	-	-	-	-	-	-	-	-	-
	8	400	189	0.02	4	28	23	25	25	28	29	29	25	26	28	30	31
		300	142	0.01	2	23	-	21	20	21	24	20	22	23	24	26	28
		200	94	0.01	2	-	-	20	20	20	20	-	-	-	-	20	21
		100	47	0.01	2	-	-	-	-	-	-	-	-	-	-	-	-
2	6	550	260	0.21	52	-	-	-	-	20	23	25	25	26	28	30	31
		400	189	0.08	20	-	-	-	-	-	-	22	22	23	24	26	29
		275	130	0.01	2	-	-	-	-	-	-	-	20	21	22	25	29
	8	800	378	0.11	27	28	24	23	21	24	24	31	30	30	31	33	34
		700	330	0.08	19	24	23	20	21	23	25	29	28	28	30	31	34
		550	260	0.04	10	-	-	-	-	-	21	25	24	25	28	29	30
		400	189	0.02	4	-	-	-	-	-	-	22	22	23	24	25	28
		275	130	0.01	2	-	-	-	-	-	-	-	20	21	22	24	28
	10	800	378	0.03	7	28	24	21	21	23	24	31	30	30	31	33	34
		700	330	0.02	4	24	21	-	20	23	23	29	28	28	29	31	34
		550	260	0.01	2	-	-	-	-	-	20	25	24	25	26	29	30
		400	189	0.01	2	-	-	-	-	-	-	22	21	22	23	25	27
275		130	0.01	2	-	-	-	-	-	-	-	-	20	21	22	26	
3	6	550	260	0.22	55	23	25	28	29	31	31	28	28	28	30	31	34
		400	189	0.09	22	-	-	-	-	23	24	22	21	22	24	25	28
	8	1100	519	0.15	37	35	35	35	36	35	36	35	38	36	38	38	38
		900	425	0.09	22	31	31	31	33	33	33	31	34	34	34	34	35
		650	307	0.04	10	23	23	25	26	28	29	28	26	28	29	31	34
		400	189	0.01	2	-	-	-	-	20	21	22	21	21	23	25	28
	10	1150	543	0.05	12	36	35	35	35	35	35	36	38	38	38	38	38
		1100	519	0.05	12	35	35	34	35	35	35	35	38	36	38	38	38
		900	425	0.04	9	31	31	30	31	31	33	31	34	34	34	34	35
		650	307	0.02	4	23	21	23	24	25	26	28	26	26	29	31	34
	400	189	0.01	1	-	-	-	-	-	-	22	20	21	23	24	26	
	4	10	1950	920	0.20	50	34	34	34	36	37	38	43	39	40	41	44
1800			849	0.17	42	33	31	33	35	36	37	40	38	39	40	43	44
1450			684	0.12	29	26	26	28	31	33	34	36	35	37	39	40	43
1100			519	0.08	19	20	20	24	28	29	29	31	31	33	35	37	39
800			378	0.05	11	-	-	-	-	20	20	28	26	29	32	34	36
14 x 10		1950	920	0.13	32	34	33	33	35	36	37	43	39	40	41	44	45
		1800	849	0.12	30	33	31	31	34	35	36	40	38	39	40	43	44
		1450	684	0.08	20	26	25	26	30	31	33	36	34	36	38	40	41
		1100	519	0.05	11	20	-	23	25	26	28	31	31	32	34	37	38
		800	378	0.03	7	-	-	-	-	-	-	28	26	29	31	34	36

Performance Notes:

1. NC Levels are calculated based on procedures as outlined on page C132.
2. Dash (-) in space indicates a NC less than 20.

FAN POWERED TERMINAL UNITS

Performance Data • Radiated Sound Power Levels

Model Series 37S • Low Profile • Series Flow • Basic Unit

Fiberglass Liner



Unit Size	Inlet Size	Airflow		Min. inlet ΔPs		Fan Only		Fan and 100% Primary Air – Sound Power Octave Bands @ Inlet pressure (ΔPs) shown																																		
								Minimum ΔPs							0.5" w.g. (125Pa) ΔPs							1.0" w.g. (249Pa) ΔPs							1.5" w.g. (375Pa) ΔPs							2.0" w.g. (500Pa) ΔPs						
								2	3	4	5	6	7	2	3	4	5	6	7	2	3	4	5	6	7	2	3	4	5	6	7	2	3	4	5	6	7					
1	6	400	189	0.15	37	65	59	54	52	44	37	62	56	51	49	41	33	62	57	51	49	45	42	63	58	52	51	49	47	64	60	53	53	52	53	65	61	54	54	54	56	
		300	142	0.07	17	56	50	46	43	34	26	58	53	49	45	37	30	59	53	49	46	43	40	60	55	50	48	46	44	60	57	51	50	49	49	61	58	52	51	51	52	
		200	94	0.02	5	49	45	43	39	29	20	50	44	42	39	28	19	51	46	42	41	37	34	52	49	44	44	40	39	53	51	47	46	44	44	54	53	48	48	46	47	
		100	47	0.01	1	-	41	39	35	24	-	-	39	38	35	24	-	-	42	39	37	29	26	-	43	40	39	33	31	-	43	40	41	38	37	-	43	41	42	41	41	40
	8	400	189	0.02	4	65	59	54	52	44	37	62	56	51	48	40	33	62	57	51	49	45	41	63	58	52	51	48	47	64	60	53	52	52	52	65	61	54	53	54	56	
		300	142	0.01	2	56	50	46	43	34	26	58	53	48	45	36	29	59	53	49	46	42	39	60	55	50	48	45	44	60	57	51	49	48	48	61	58	52	50	51	51	
		200	94	0.01	2	49	45	43	39	29	20	50	44	42	38	28	19	51	46	42	41	36	33	52	49	44	43	40	38	53	51	46	45	43	43	54	53	47	47	45	46	
		100	47	0.01	2	-	41	39	35	24	-	-	39	38	34	23	-	-	42	39	36	29	25	-	42	39	38	33	30	-	43	40	40	37	36	-	43	41	41	39	39	
	2	6	550	260	0.21	52	59	52	51	51	41	32	56	51	51	51	40	33	57	52	52	51	45	46	59	55	53	53	49	51	62	58	55	55	54	56	63	60	56	57	57	60
			400	189	0.08	20	53	49	48	47	36	26	51	49	48	48	36	28	54	49	49	50	44	45	56	52	50	52	49	50	58	54	52	54	55	55	59	56	53	56	59	59
			275	130	0.01	2	49	47	45	44	33	22	49	47	46	44	33	22	52	48	47	48	43	39	53	50	48	49	49	47	54	52	49	51	55	55	55	54	50	52	59	61
		8	800	378	0.11	27	67	60	56	56	48	40	63	58	55	56	46	38	64	58	55	56	48	47	65	60	56	57	52	53	66	62	57	59	55	58	66	63	58	60	60	61
700			330	0.08	19	64	57	54	54	45	37	60	55	53	54	43	36	61	56	53	55	46	47	62	59	55	56	51	52	64	61	56	57	55	57	65	63	57	57	57	61	
550			260	0.04	10	59	52	51	51	41	32	56	51	50	51	39	33	57	52	51	51	44	45	59	55	53	53	49	50	62	58	54	55	54	55	63	60	55	56	57	59	
400			189	0.02	4	53	49	48	47	36	26	51	49	48	47	36	27	54	49	49	49	43	43	56	52	50	51	48	48	58	54	51	53	54	54	59	56	53	54	58	57	
275		130	0.01	2	49	47	45	44	33	22	49	46	46	43	32	22	52	48	47	47	42	38	53	50	48	48	48	46	54	52	49	50	54	54	54	53	49	51	58	59		
10		800	378	0.03	7	67	60	56	56	48	40	63	58	55	55	46	38	64	58	55	55	48	47	65	60	56	57	51	52	66	62	57	58	54	57	66	63	58	59	59	61	
		700	330	0.02	4	64	57	54	54	45	37	60	55	53	53	43	35	61	56	53	54	46	46	62	59	54	55	50	51	64	61	56	56	54	56	65	63	57	57	57	60	
		550	260	0.01	2	59	52	51	51	41	32	56	51	50	50	39	32	57	52	51	50	44	44	59	55	52	52	49	49	62	58	54	54	53	54	63	60	55	55	56	58	
		400	189	0.01	2	53	49	48	47	36	26	51	49	47	46	35	26	54	49	48	48	42	42	56	52	49	50	48	47	58	54	51	52	53	52	59	56	52	53	57	56	
275	130	0.01	2	49	47	45	44	33	22	48	46	45	42	31	21	51	48	46	46	41	37	52	49	47	48	47	45	53	51	48	49	52	52	54	53	49	50	56	57			
3	6	550	260	0.22	55	63	54	53	52	43	34	62	54	53	53	43	34	62	55	53	53	46	48	63	58	55	55	50	53	65	61	56	56	54	58	65	63	57	57	57	62	
		400	189	0.09	22	54	49	48	46	37	27	53	48	47	45	35	23	55	50	48	47	43	43	57	53	50	49	48	60	56	51	51	52	54	61	58	53	52	55	58		
		1100	519	0.15	37	70	63	59	59	52	44	72	65	59	61	54	50	71	65	60	60	54	50	72	65	60	61	55	54	72	66	61	62	56	59	72	67	62	63	57	62	
	8	900	425	0.09	22	67	59	56	56	49	40	69	61	57	57	48	39	69	61	57	57	50	49	69	62	58	58	52	53	69	63	59	59	54	58	70	64	60	59	55	62	
		650	307	0.04	10	63	54	53	52	43	34	62	54	52	52	42	33	62	55	53	52	45	46	63	58	54	54	49	51	65	61	55	55	53	57	65	63	56	56	56	60	
		400	189	0.01	2	54	49	48	46	37	27	53	47	47	45	34	22	54	49	47	46	42	41	57	52	49	48	46	47	59	56	51	50	51	52	61	58	52	51	54	56	
		1150	543	0.05	12	71	64	60	60	53	45	72	65	60	61	54	46	72	65	60	57	51	47	72	66	61	61	54	54	72	66	61	62	56	58	72	67	62	62	56	61	
	10	1100	519	0.05	12	70	63	59	59	52	44	72	65	59	60	53	50	71	65	60	60	53	49	72	65	60	61	54	54	72	66	61	61	55	58	72	67	62	62	56	61	
		900	425	0.04	9	67	59	56	56	49	40	69	61	56	56	48	39	69	61	57	57	49	48	69	62	58	57	51	52	69	63	59	58	53	57	70	64	59	59	55	60	
		650	307	0.02	4	63	54	53	52	43	34	62	54	52	51	41	32	62	55	52	51	45	45	63	58	54	53	48	50	65	61	55	54	52	55	65	63	56	55	55	58	
		400	189	0.01	1	54	49	48	46	37	27	52	47	46	44	33	22	54	49	47	45	41	40	56	52	49	47	45	45	58	55	50	49	49	51	60	57	52	50	52	54	
	4	10	1950	920	0.20	50	76	69	65	63	54	46	73	68	64	62	53	45	73	68	65	63	54	48	74	70	66	64	57	53	75	71	68	66	60	58	76	72	69	67	62	62
1800			849	0.17	42	74	67	64	61	52	44	72	66	63	60	51	43	72	67	64	61	53	47	73	69	65	63	56	53	74	70	67	65	60	58	75	72	68	66	62	62	
1450			684	0.12	29	71	63	61	57	47	39	68	62	60	57	46	38	69	64	62	58	50	45	70	66	64	60	54	52	71	67	65	62	59	59	72	69	67	64	62	64	
1100			519	0.08	19	64	58	56	52	41	32	64	58	56	52	41	32	63	59	58	55	48	44	65	62	60	57	54	51	67	65	62	60	59	59	69	66	64	62	63	65	
800			378	0.05	11	60	54	53	48	36	26	56	53	52	47	35	24	59	55	54	51	48	42	61	58	57	54	54	51	63	61	59	57	60	59	65	63	61	59	64	65	
14 x 10		1950	920	0.13	32	76	69	65	63	54	46	73	68	64	61	52	44	73	68	65	62	54	48	74	70	66	64	57	53	75	71	68	65	59	58	76	72	69	66	61	61	
		1800	849	0.12	30	74	67	64	61	52	44	72	66	63	60	50	42	72	67	64	61	53	47	73	69	65	62	56	52	74	70	67	64	59	58	75	72	68	65	61	62	
		1450	684	0.08	20	71	63	61	57	47	39	68	62	59	56	46	37	69	64	6																						

Performance Data

ECM Motor Fan Curves – Airflow vs. Downstream Static Pressure

37SST Stealth™ Series • Low Profile • Series Flow

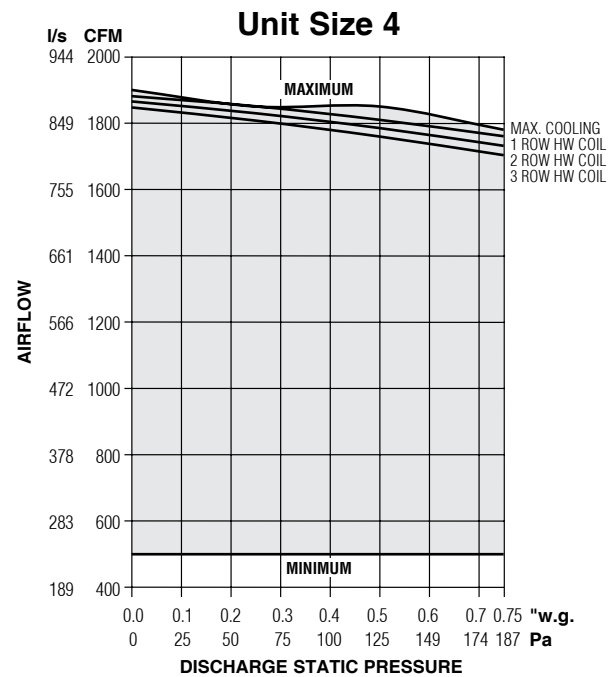
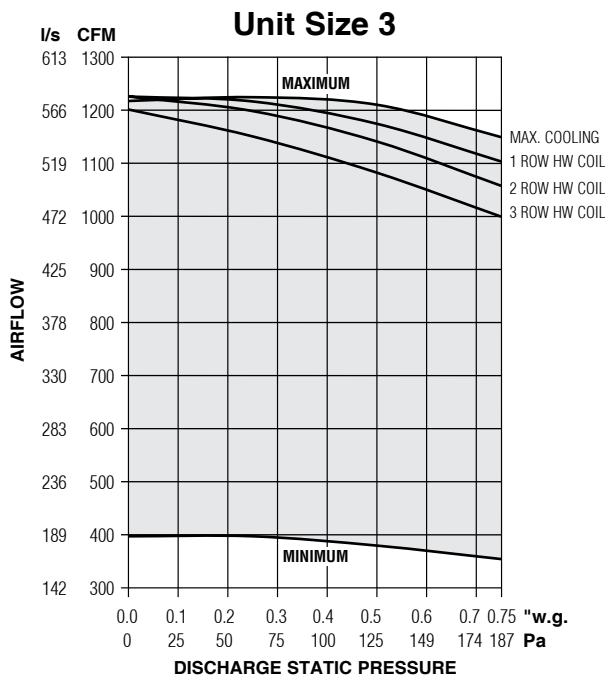
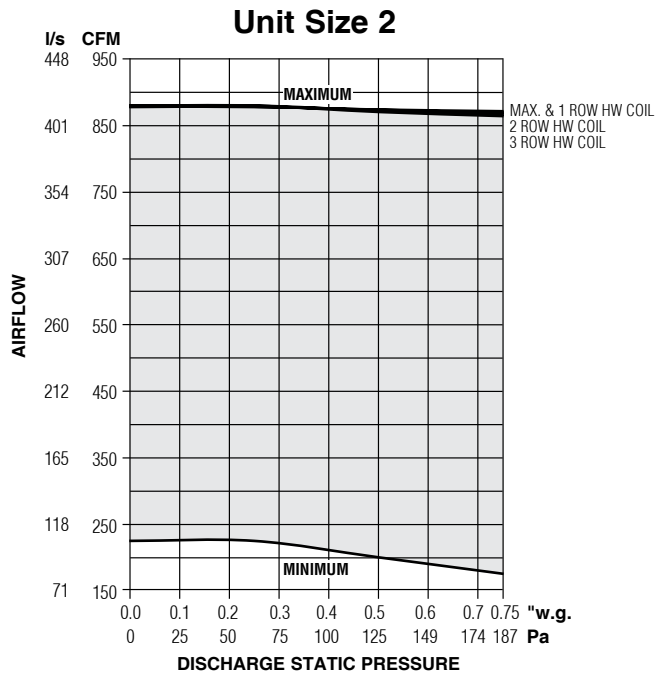
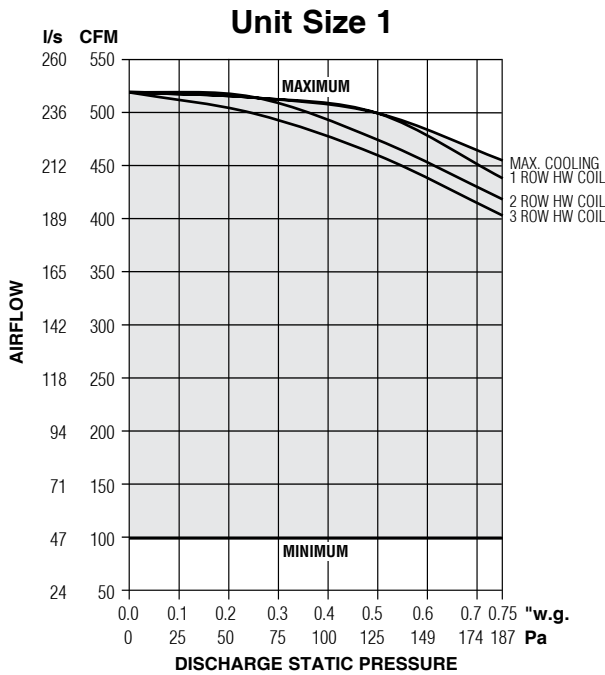

Electrical Data

Unit Size	EPIC ECM Motor FLA				
	Motor HP	120V	208V	240V	277V
1	*	1.9	1.3	1.3	1.3
2	*	3.3	2.2	2.2	2.2
3	*	6.9	4.7	4.4	4.4
4	*	8.0	5.4	5.2	4.9

* The EPIC ECM is a variable horsepower motor. Refer to Selectworks schedule for actual power consumption. FLA = Full load amperage. All motors are single phase/60 Hz.

NOTES:

- The ECM is pressure independent and constant volume in operation at factory or field set point within the shaded area. Airflow does not vary with changing static pressure conditions. The motor compensates for any changes in external static pressure or induced air conditions such as filter loading.
- Airflow can be set to operate on horizontal performance line at any point within shaded area using the solid state volume controller provided.
- Fan curves shown are applicable to 120, 208, 240 and 277 volt, single phase ECM's. ECM's, although DC in operation, include a built-in inverter.

Performance Data

PSC Motor Fan Curves – Airflow vs. Downstream Static Pressure

37SST "Stealth™" Series • Low Profile • Series Flow

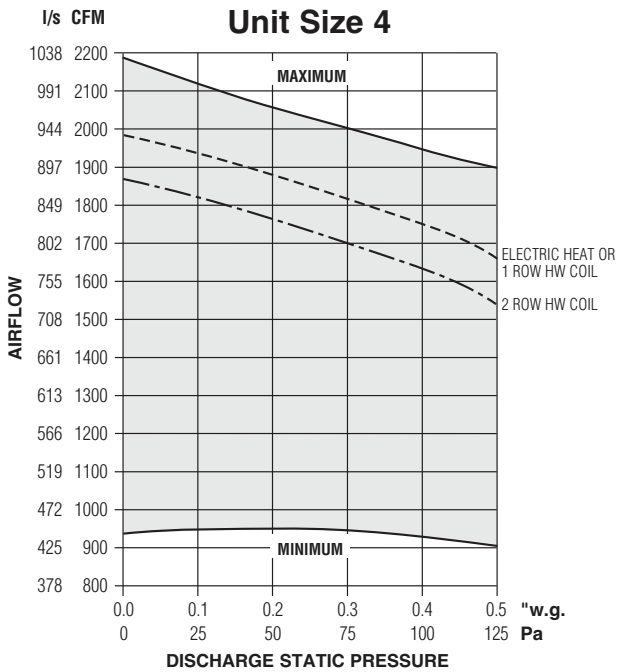
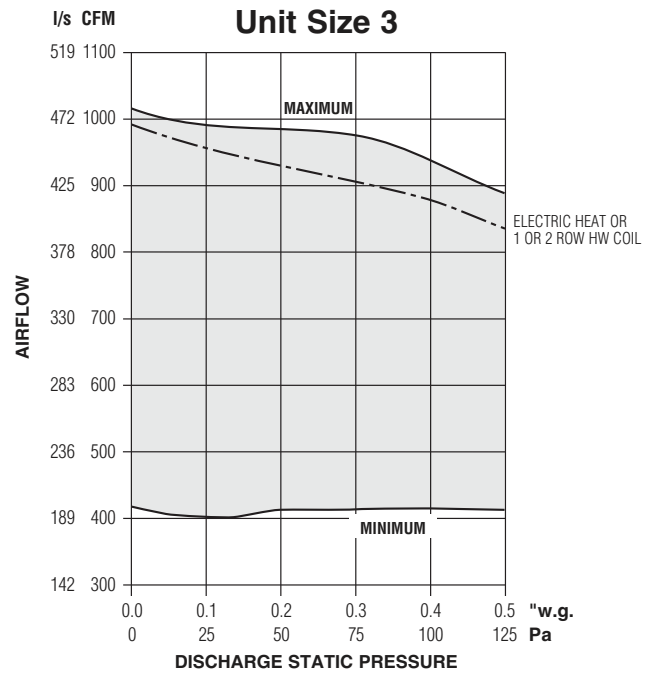
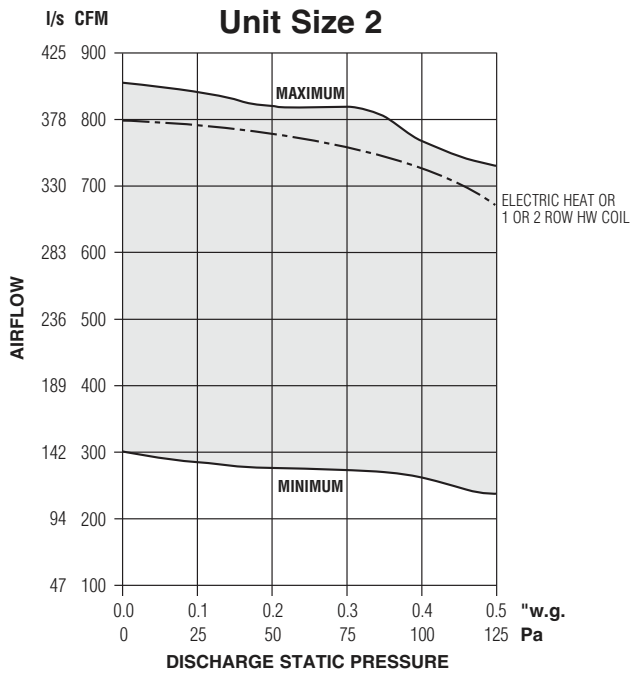

- Fan curves shown are applicable to 120, 208, 240 and 277 volt, single phase PSC motors.

Electrical Data

Unit Size	PSC Motor FLA	PSC Motor FLA			
		Motor HP	120V	208V	240V
2	1/6	4.8	1.8	1.8	1.5
3	1/4	5.3	3.6	3.6	1.8
4	2@1/4	10.6	7.2	7.2	3.7

FLA = Full load amperage.
All motors are single phase/60 Hz.



Performance Data • AHRI Certification and Performance Notes

Model Series 37SST "Stealth™" • Low Profile • Series Flow • AHRI Certification Rating Points
Fiberglass Liner

Unit Size	Inlet Size	Fan Airflow		Fan ^Σ Watts	Fan Only* @ .25" w.g. (62 Pa) ΔPs												Primary Airflow		Min. Inlet ΔPs	Fan + 100% Primary @ 1.5" w.g. (375 Pa) ΔPs w/ .25" w.g. (62 Pa) Discharge ΔPs						
					Discharge						Radiated									Radiated						
		cfm	l/s		2	3	4	5	6	7	2	3	4	5	6	7	cfm	l/s		"w.g.	Pa	2	3	4	5	6
1	8	400	189	140	72	67	62	58	54	50	63	58	52	47	42	36	400	189	0.02	4	62	59	50	46	43	40
2	10	800	378	170	70	69	66	64	61	58	65	58	54	51	42	36	800	378	0.03	7	66	61	55	53	50	47
3	10	1100	519	400	76	74	68	68	66	63	67	61	57	57	48	39	1100	519	0.05	12	70	64	58	54	47	45
4	14 x 10	1800	849	600	77	73	72	72	70	67	70	62	56	52	47	42	1800	849	0.12	30	74	67	59	55	53	53

^Σ Motor = ECM.

* Primary air valve is closed and therefore primary cfm is zero.



Ratings are certified in accordance with AHRI Standards.

Performance Notes for Sound Power Levels:

- Discharge (external) static pressure is 0.25" w.g. (63 Pa) in all cases, which is the difference (ΔPs) in static pressure from terminal discharge to the room.
Discharge Sound Power Levels (SWL) now include duct end reflection energy as part of the standard rating. Including the duct end correction provides sound power levels that would normally be transmitted into an acoustically, non-reflective duct. The effect of including the energy correction to the discharge SWL, is higher sound power levels when compared to previous AHRI certified data. For more information on duct end reflection calculations see AHRI Standard 880.
- Radiated sound power is the breakout noise transmitted through the unit casing walls.
- Sound power levels are in decibels, dB re 10⁻¹² watts.
- All sound data listed by octave bands is raw data without any corrections for room absorption or duct attenuation. Dash (-) in space indicates sound power level is less than 20 dB or equal to background.
- Min. inlet ΔPs is the minimum operating pressure of the primary air valve section.
- Asterisk (*) in space indicates that the minimum inlet static pressure requirement is greater than 0.5" w.g. (125 Pa) at rated airflow.
- Data derived from independent tests conducted in accordance with ANSI / ASHRAE Standard 130 and AHRI Standard 880.

FAN POWERED TERMINAL UNITS

Performance Data • Discharge Sound Power Levels

Model Series 37SST "Stealth™" • Low Profile • Series Flow

Fiberglass Liner



Unit Size	Inlet Size	Airflow		Min. inlet ΔPs		Fan Only		Fan and 100% Primary Air – Sound Power Octave Bands @ Inlet pressure (ΔPs) shown																																		
								Minimum ΔPs							0.5" w.g. (125Pa) ΔPs							1.0" w.g. (249Pa) ΔPs							1.5" w.g. (375Pa) ΔPs							2.0" w.g. (500Pa) ΔPs						
								2	3	4	5	6	7	2	3	4	5	6	7	2	3	4	5	6	7	2	3	4	5	6	7	2	3	4	5	6	7					
1	6	400	189	0.15	37	72	67	62	58	54	50	70	64	59	51	47	41	71	64	58	51	47	42	71	66	59	52	49	44	71	65	57	46	39	31	70	66	58	46	40	32	
		300	142	0.07	17	68	62	57	52	47	41	66	58	53	45	39	33	67	59	53	45	39	33	67	63	55	46	41	36	68	62	54	40	31	22	68	63	56	42	33	24	
		200	94	0.02	5	67	60	54	49	43	36	64	52	45	37	30	22	65	54	45	36	29	20	65	58	48	33	24	-	67	62	56	42	34	28	67	63	57	44	35	28	
		100	47	0.01	1	63	56	50	44	37	29	60	47	38	30	23	-	61	49	39	29	-	-	62	54	43	25	-	-	65	61	55	39	31	24	64	61	56	41	32	24	
	8	400	189	0.02	4	72	67	62	58	54	50	69	63	58	51	47	41	70	64	58	51	47	42	70	66	58	52	49	44	70	65	56	46	39	31	70	65	58	46	40	32	
		300	142	0.01	2	68	62	57	52	47	41	65	57	52	44	39	33	66	58	52	45	39	33	66	62	54	46	41	36	67	62	53	40	31	22	67	63	55	42	33	24	
		200	94	0.01	2	67	60	54	49	43	36	62	51	44	37	30	22	63	53	44	36	29	20	64	57	47	33	24	-	65	61	55	42	34	28	65	61	56	43	35	28	
		100	47	0.01	2	63	56	50	44	37	29	58	45	37	29	22	-	59	48	38	29	-	-	60	52	42	24	-	-	63	60	54	39	30	24	62	59	55	41	32	24	
2	6	550	260	0.21	52	63	62	59	56	53	48	65	60	58	54	49	43	67	58	57	52	47	41	65	60	58	53	47	41	67	61	58	53	47	41	67	62	58	53	47	41	
		400	189	0.08	20	61	57	55	51	47	40	64	58	56	51	45	36	64	57	55	48	43	34	64	57	55	48	42	34	65	58	56	49	43	34	67	59	56	49	43	35	
		275	130	0.01	2	59	52	50	46	40	30	62	58	51	46	40	29	64	53	49	43	36	24	63	55	51	43	36	25	64	56	52	44	37	26	66	56	53	45	38	28	
	8	800	378	0.11	27	70	69	66	64	61	58	68	66	62	59	55	51	67	64	61	57	53	50	68	64	61	56	52	49	69	65	61	57	53	49	70	65	61	57	53	49	
		700	330	0.08	19	67	66	63	60	57	54	67	64	61	57	53	48	67	62	59	55	51	47	67	63	60	55	51	46	68	63	60	55	51	46	69	64	60	56	51	46	
		550	260	0.04	10	63	62	59	56	53	48	64	60	58	54	49	43	65	58	56	52	47	41	64	60	57	52	47	41	65	60	57	52	47	41	66	61	58	52	47	41	
		400	189	0.02	4	61	57	55	51	47	40	62	57	55	50	45	36	62	55	54	48	43	34	62	56	54	48	42	34	64	57	55	49	43	34	65	58	55	49	43	35	
	275	130	0.01	2	59	52	50	46	40	30	60	56	50	45	39	28	62	52	49	43	36	24	61	53	50	43	36	25	62	54	51	44	37	26	64	55	52	44	37	28		
	10	800	378	0.03	7	70	69	66	64	61	58	68	66	61	59	55	51	66	63	60	57	53	50	67	63	61	56	52	49	68	64	60	57	53	49	69	64	61	57	53	49	
		700	330	0.02	4	67	66	63	60	57	54	66	63	60	57	53	48	66	61	59	55	51	47	66	62	59	55	51	46	67	63	59	55	51	46	68	63	59	55	51	46	
		550	260	0.01	2	63	62	59	56	53	48	63	59	57	53	49	43	64	57	56	51	47	41	63	59	57	52	47	41	64	60	57	51	47	41	65	61	57	52	47	41	
		400	189	0.01	2	61	57	55	51	47	40	60	56	54	50	45	36	61	54	53	48	43	34	60	55	53	48	42	34	62	56	54	48	43	34	63	57	54	48	43	35	
275		130	0.01	2	59	52	50	46	40	30	58	54	49	45	39	28	60	50	48	42	35	24	60	51	49	43	36	24	60	53	50	44	36	26	62	53	51	44	37	27		
3	6	550	260	0.22	55	68	63	60	59	55	51	71	65	61	58	53	49	72	66	61	58	53	49	73	66	61	58	53	49	74	67	62	58	54	49	75	68	62	59	54	49	
		400	189	0.09	22	63	58	56	53	49	44	62	59	56	51	47	41	64	59	56	52	47	41	65	61	56	52	47	41	67	62	57	52	47	41	68	63	57	52	47	41	
	8	1100	519	0.15	37	76	74	68	68	66	63	78	75	70	70	67	65	77	74	69	68	65	63	79	75	70	68	66	63	79	75	70	68	65	63	80	75	70	68	65	62	
		900	425	0.09	22	74	71	66	66	63	60	76	72	67	67	63	60	77	72	66	65	62	59	77	72	67	66	62	59	78	72	67	66	62	59	79	73	67	66	62	59	
		650	307	0.04	10	68	63	60	59	55	51	69	64	60	57	53	49	70	64	60	57	53	49	71	64	60	57	53	49	72	66	61	58	54	49	73	67	61	58	54	49	
	400	189	0.01	2	63	58	56	53	49	44	60	57	55	51	46	40	62	58	55	51	47	40	64	59	55	51	47	40	65	60	56	51	46	40	66	61	56	51	46	40		
	10	1150	543	0.05	12	77	75	69	68	66	64	77	75	70	70	68	65	77	74	69	68	66	63	78	75	69	68	66	63	79	75	69	68	66	63	80	75	69	68	66	63	
		1100	519	0.05	12	76	74	68	66	63	60	77	74	70	70	67	65	77	73	68	68	65	63	78	74	69	68	66	63	78	74	69	68	65	63	79	75	69	68	65	62	
		900	425	0.04	9	74	71	66	66	63	60	75	71	66	66	63	60	76	71	65	65	62	59	76	71	66	65	62	59	77	72	66	65	62	59	77	72	67	65	62	59	
		650	307	0.02	4	68	63	60	59	55	51	67	63	59	57	53	49	68	63	59	57	53	49	69	63	59	57	53	49	70	65	60	57	54	49	71	66	60	57	54	49	
400		189	0.01	1	63	58	56	53	49	44	58	56	54	50	46	40	60	56	53	51	46	40	62	57	54	51	46	40	63	59	55	50	46	40	64	59	55	51	46	40		
4	10	1950	920	0.20	50	79	75	74	74	72	69	77	74	72	72	70	67	78	75	73	73	71	68	79	76	74	74	71	69	81	77	76	75	72	70	81	78	76	75	72	70	
		1800	849	0.17	42	77	73	72	72	70	67	75	72	71	71	68	65	76	73	72	71	69	66	78	74	73	72	70	67	79	76	74	73	71	68	80	77	75	73	71	68	
		1450	684	0.12	29	71	68	67	67	64	61	71	67	67	67	63	60	73	69	68	68	64	62	75	71	70	69	66	63	77	72	71	70	66	64	77	73	71	71	67	64	
		1100	519	0.08	19	64	60	62	61	58	54	65	61	63	60	56	52	68	64	64	62	59	55	70	66	66	64	60	56	72	68	67	65	61	57	73	68	68	65	61	58	
	800	378	0.05	11	59	57	59	58	54	48	59	56	59	56	52	45	63	58	60	58	54	48	64	60	61	58	55	49	66	62	62	59	56	50	67	63	63	60	56	51		
	14 x 10	1950	920	0.13	32	79	75	74	74	72	69	76	73	72	72	70	67	77	74	73	73	71	68	78	75	74	74	71	69	80	76	75	75	72	70	80	77	75	75	72	70	
		1800	849	0.12	30	77	73	72	72	70	67	74	71	70	71	68	65	76	73	71	71	69	66	77	73	72	72	70	67	79	75	73	73	71	68	79	76	74	73	71	68	
		1450	684	0.08	20	71	68	67	67	64	61	70	67	66	66	63	60	72	68																							

Performance Data • NC Level Application Guide

Model Series 37SST "Stealth™" • Low Profile • Series Flow

Fiberglass Liner

Unit Size	Inlet Size	Airflow		Min. inlet ΔPs		NC Levels @ Inlet Pressure (ΔPs) shown												
						DISCHARGE					RADIATED							
						Fan Only	Min. ΔPs	0.5" w.g. (125 Pa)	1.0" w.g. (250 Pa)	1.5" w.g. (375 Pa)	2.0" w.g. (500 Pa)	Fan Only	Min. ΔPs	0.5" w.g. (125 Pa)	1.0" w.g. (250 Pa)	1.5" w.g. (375 Pa)	2.0" w.g. (500 Pa)	
1	6	400	189	0.15	37	26	24	25	25	25	25	28	25	25	28	29	30	
		300	142	0.07	17	21	-	20	21	21	21	-	20	21	23	25	26	
		200	94	0.02	5	24	20	21	21	24	24	-	-	-	-	-	-	
		100	47	0.01	1	-	-	-	-	21	20	-	-	-	-	-	-	
	8	400	189	0.02	4	26	23	24	25	24	24	28	25	25	28	29	30	
		300	142	0.01	2	21	-	-	20	20	21	-	20	21	23	25	26	
		200	94	0.01	2	24	-	-	20	21	21	-	-	-	-	-	-	
		100	47	0.01	2	-	-	-	-	-	-	-	-	-	-	-	-	
2	6	550	260	0.21	52	20	-	20	-	20	20	22	22	23	24	26	29	
		400	189	0.08	20	-	-	-	-	20	20	-	-	20	22	24	28	
		275	130	0.01	2	-	-	20	-	20	23	-	-	-	-	24	28	
	8	800	378	0.11	27	28	24	21	21	23	23	29	28	26	29	31	34	
		700	330	0.08	19	25	23	20	21	21	23	26	25	26	28	30	33	
		550	260	0.04	10	20	-	-	-	-	-	22	21	22	24	26	29	
		400	189	0.02	4	-	-	-	-	-	-	-	-	-	21	23	26	
		275	130	0.01	2	-	-	-	-	-	20	-	-	-	-	23	27	
	10	800	378	0.03	7	28	24	20	20	21	21	29	28	26	29	31	34	
		700	330	0.02	4	25	21	-	20	21	21	26	24	25	28	30	33	
		550	260	0.01	2	20	-	-	-	-	-	22	21	22	24	26	29	
		400	189	0.01	2	-	-	-	-	-	-	-	-	-	21	23	25	
		275	130	0.01	2	-	-	-	-	-	-	-	-	-	-	21	25	
	3	6	550	260	0.22	55	21	25	26	28	29	30	24	23	23	24	28	30
			400	189	0.09	22	-	-	-	-	20	21	-	-	-	-	23	25
		8	1100	519	0.15	37	34	35	34	35	35	35	32	34	34	35	35	35
900			425	0.09	22	30	31	31	31	31	33	30	31	31	31	33	33	
650			307	0.04	10	21	23	24	25	26	28	24	23	23	24	28	30	
400			189	0.01	2	-	-	-	-	-	-	-	-	-	-	21	24	
10		1150	543	0.05	12	35	35	34	35	35	35	33	34	34	34	35	36	
		1100	519	0.05	12	34	34	33	34	34	35	32	34	34	35	35	35	
		900	425	0.04	9	30	30	30	30	31	31	30	31	31	31	33	33	
		650	307	0.02	4	21	21	21	23	24	25	24	23	23	24	28	30	
400	189	0.01	1	-	-	-	-	-	-	-	-	-	-	21	24			
4	10	1950	920	0.20	50	35	34	35	36	37	38	38	39	39	40	41	43	
		1800	849	0.17	42	33	31	33	34	36	37	35	38	38	39	40	41	
		1450	684	0.12	29	26	25	28	30	31	33	31	33	34	35	36	38	
		1100	519	0.08	19	-	-	21	24	26	26	25	28	26	29	31	34	
		800	378	0.05	11	-	-	-	-	-	20	20	-	21	25	28	30	
	14 x 10	1950	920	0.13	32	35	33	34	35	36	37	38	39	39	40	41	43	
		1800	849	0.12	30	33	30	33	33	35	36	35	38	38	39	40	41	
		1450	684	0.08	20	26	25	26	29	30	31	31	33	34	35	36	38	
		1100	519	0.05	11	-	-	-	21	25	25	25	28	26	29	31	34	
		800	378	0.03	7	-	-	-	-	-	-	20	-	21	24	28	30	

Performance Notes:

1. NC Levels are calculated based on procedures as outlined on page C132.
2. Dash (-) in space indicates a NC less than 20.

FAN POWERED TERMINAL UNITS

Performance Data • Radiated Sound Power Levels

Model Series 37SST "Stealth™" • Low Profile • Series Flow

Fiberglass Liner



Unit Size	Inlet Size	Airflow		Min. inlet ΔPs		Fan Only		Fan and 100% Primary Air – Sound Power Octave Bands @ Inlet pressure (ΔPs) shown																																		
								Minimum ΔPs					0.5" w.g. (125Pa) ΔPs					1.0" w.g. (249Pa) ΔPs					1.5" w.g. (375Pa) ΔPs					2.0" w.g. (500Pa) ΔPs														
								2	3	4	5	6	7	2	3	4	5	6	7	2	3	4	5	6	7	2	3	4	5	6	7	2	3	4	5	6	7					
1	6	400	189	0.15	37	63	58	52	47	42	36	60	56	49	44	39	33	60	56	49	45	40	34	61	58	50	46	42	37	62	59	50	46	44	40	63	60	51	47	45	43	
		300	142	0.07	17	55	51	44	38	33	26	56	52	46	41	35	29	58	53	47	41	36	30	58	54	47	42	38	34	58	56	48	43	40	37	59	57	49	43	41	40	
		200	94	0.02	5	50	45	41	34	27	19	-	43	39	33	25	-	49	45	40	34	28	21	50	47	41	36	32	28	51	50	43	38	36	34	51	51	44	40	39	39	
		100	47	0.01	1	-	40	36	30	22	-	-	40	36	29	21	-	-	41	36	30	23	18	-	41	37	32	27	25	-	42	37	34	31	31	-	42	37	35	34	36	
	8	400	189	0.02	4	63	58	52	47	42	36	60	56	49	44	39	32	60	56	49	45	39	33	61	58	50	45	41	37	62	59	50	46	43	40	63	60	51	46	45	42	
		300	142	0.01	2	55	51	44	38	33	26	56	52	46	40	35	28	58	53	46	41	36	30	58	54	47	42	38	33	58	56	48	42	40	37	59	57	48	43	41	39	
		200	94	0.01	2	50	45	41	34	27	19	-	43	39	32	25	-	49	45	39	34	27	20	50	47	41	35	31	27	51	50	42	37	35	33	51	51	43	39	38	38	
		100	47	0.01	2	-	40	36	30	22	-	-	39	36	29	21	-	-	41	36	30	23	18	-	41	36	31	26	24	-	41	37	33	30	30	-	42	37	34	33	35	
	2	6	550	260	0.21	52	57	51	48	43	35	28	56	50	48	43	34	27	57	51	49	45	37	32	60	54	50	48	43	40	62	57	52	51	50	48	64	59	53	53	55	53
			400	189	0.08	20	53	48	45	40	32	26	51	47	45	40	30	22	55	48	46	44	38	32	57	51	48	48	45	41	59	54	50	52	52	50	60	56	51	55	57	56
			275	130	0.01	2	49	45	43	38	30	23	49	45	43	36	28	20	53	47	44	44	42	33	55	49	45	46	48	43	56	51	47	49	54	54	57	52	48	51	58	62
		8	800	378	0.11	27	65	58	54	51	42	36	64	56	52	48	41	35	63	56	52	48	42	37	65	59	54	51	46	42	66	61	55	54	51	47	67	63	56	55	53	51
700			330	0.08	19	62	55	52	48	39	33	61	54	51	46	38	33	61	54	52	47	40	36	63	57	53	50	45	41	65	60	55	53	49	47	66	62	56	54	53	51	
550			260	0.04	10	57	51	48	43	35	28	56	50	47	42	33	27	57	51	48	44	36	32	60	54	50	47	43	39	62	57	52	51	49	47	64	59	53	53	54	52	
400			189	0.02	4	53	48	45	40	32	26	51	47	44	39	30	22	55	48	45	43	38	31	57	51	47	47	44	40	59	54	49	51	51	48	60	56	51	54	56	55	
10		275	130	0.01	2	49	45	43	38	30	23	48	44	42	36	27	20	53	46	43	43	41	32	54	48	45	45	47	42	56	51	46	48	53	53	57	52	48	50	57	60	
		800	378	0.03	7	65	58	54	51	42	36	64	56	52	48	41	35	63	56	52	48	42	37	65	59	54	51	46	42	66	61	55	53	50	47	67	63	56	55	53	51	
		700	330	0.02	4	62	55	52	48	39	33	61	54	50	46	38	32	61	54	51	47	40	35	63	57	53	50	45	41	65	60	54	52	49	46	66	62	55	54	52	50	
		550	260	0.01	2	57	51	48	43	35	28	56	50	47	42	33	26	57	51	48	44	36	31	60	54	50	47	43	39	62	57	51	50	49	46	64	59	52	52	54	51	
		400	189	0.01	2	53	48	45	40	32	26	51	47	44	38	29	21	55	48	45	42	37	30	57	51	47	46	44	39	59	54	49	50	50	47	60	56	50	53	55	53	
275	130	0.01	2	49	45	43	38	30	23	48	44	42	35	26	19	52	46	43	42	40	31	54	48	45	45	46	41	55	50	46	47	51	51	56	51	47	49	55	58			
3	6	550	260	0.22	55	59	52	50	44	34	26	60	52	49	44	35	27	60	52	49	45	37	33	61	55	50	47	40	38	63	58	52	48	43	43	63	60	53	49	45	46	
		400	189	0.09	22	53	46	43	37	27	-	51	45	43	37	27	-	53	47	43	39	33	27	55	50	45	41	37	33	57	54	47	44	41	39	59	56	49	46	44	43	
		1100	519	0.15	37	67	61	57	57	48	39	68	63	56	52	45	38	69	63	56	52	45	39	70	63	57	54	46	42	70	64	58	55	47	46	70	64	58	55	48	48	
	8	900	425	0.09	22	64	58	55	53	41	34	67	58	53	49	41	35	67	58	53	49	42	37	67	60	54	50	43	40	68	61	55	51	44	43	68	62	56	52	45	46	
		650	307	0.04	10	59	52	50	44	34	26	60	52	48	43	34	27	60	52	48	44	36	32	61	55	50	46	39	37	63	58	51	47	42	41	63	60	52	48	44	45	
		400	189	0.01	2	53	46	43	37	27	-	51	45	42	36	26	-	53	47	43	38	32	26	55	50	45	40	36	32	57	53	47	43	40	38	58	55	48	45	43	42	
		1150	543	0.05	12	68	62	58	58	50	41	69	62	56	52	45	39	69	63	56	52	45	40	69	63	57	53	46	42	70	64	58	54	47	45	70	65	58	55	47	47	
	10	1100	519	0.05	12	67	61	57	57	48	39	68	63	56	52	44	37	69	63	56	52	45	39	70	63	57	53	46	42	70	64	58	54	47	45	70	64	58	55	48	47	
		900	425	0.04	9	64	58	55	53	41	34	67	58	52	49	41	35	67	58	53	49	41	36	67	60	54	50	42	39	68	61	55	50	43	43	68	62	55	51	44	45	
		650	307	0.02	4	59	52	50	44	34	26	60	52	48	43	33	26	60	52	48	43	35	31	61	55	49	45	38	35	63	58	51	46	41	40	63	60	52	47	43	44	
		400	189	0.01	1	53	46	43	37	27	-	50	44	42	35	25	-	52	46	43	37	31	25	54	49	44	40	35	31	56	53	46	42	39	37	58	55	48	44	41	41	
		1950	920	0.20	50	72	64	57	54	49	44	73	65	57	54	48	42	73	65	58	54	49	44	74	66	59	55	52	49	75	68	60	56	54	54	76	68	61	57	56	57	
4	10	1800	849	0.17	42	70	62	56	52	47	42	72	63	56	52	46	40	72	63	57	53	48	43	73	65	58	54	51	48	74	67	59	56	53	53	75	68	60	57	55	57	
		1450	684	0.12	29	67	58	53	49	43	36	68	59	53	48	41	35	69	60	54	49	44	40	70	62	56	51	48	46	71	64	58	53	52	52	72	65	60	55	55	56	
		1100	519	0.08	19	62	54	49	44	37	29	64	54	49	44	36	29	63	55	50	46	43	39	65	58	53	49	47	46	67	61	56	52	52	52	69	63	57	54	55	57	
		800	378	0.05	11	58	50	46	40	32	23	57	49	45	38	30	21	59	52	47	43	42	37	62	55	50	47	47	45	64	58	53	51	52	52	66	60	55	53	56	58	
		1950	920	0.13	32	72	64	57	54	49	44	73	65	57	53	48	41	73	65	58	54	49	44	74	66	59	55	51	48	75	68	60	56	54	53	76	68	61	57	55	56	
	14 x 10	1800	849	0.12	30	70	62	56	52	47	42	72	63	56	52	45	39	72	63	57	52	47	43	73	65	58	54	50	48	74	67	59	55	53	53	75	68	60	56	55	56	
		1450	684	0.08	20	67	58	53	49	43	36	68	59	53	48	41	34	69	60	54	49	44	40</																			

Performance Data • Hot Water Coil

Models: 37SW and 37SWST • Low Profile • Series Flow

Unit Size 1

1 Row (single circuit)

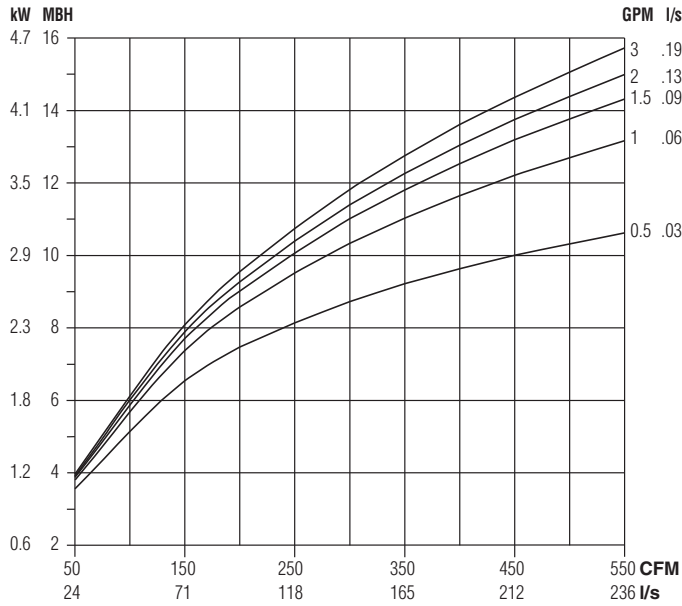

2 Row (multi-circuit)

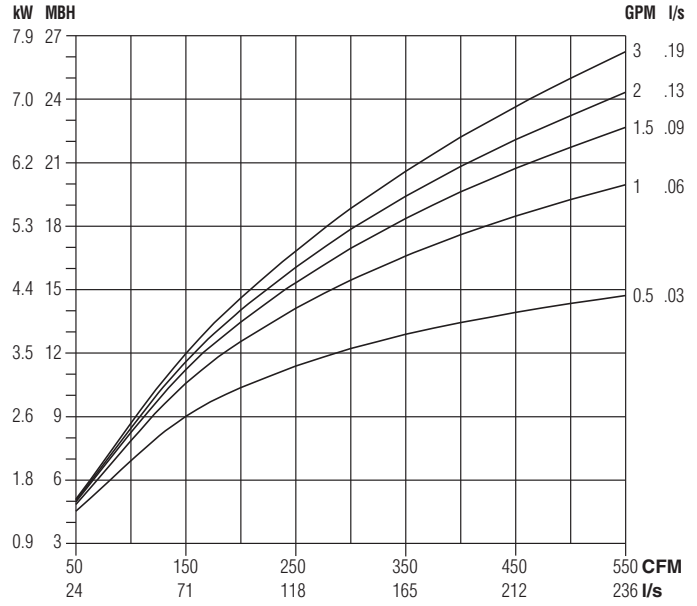

3 Row (multi-circuit)

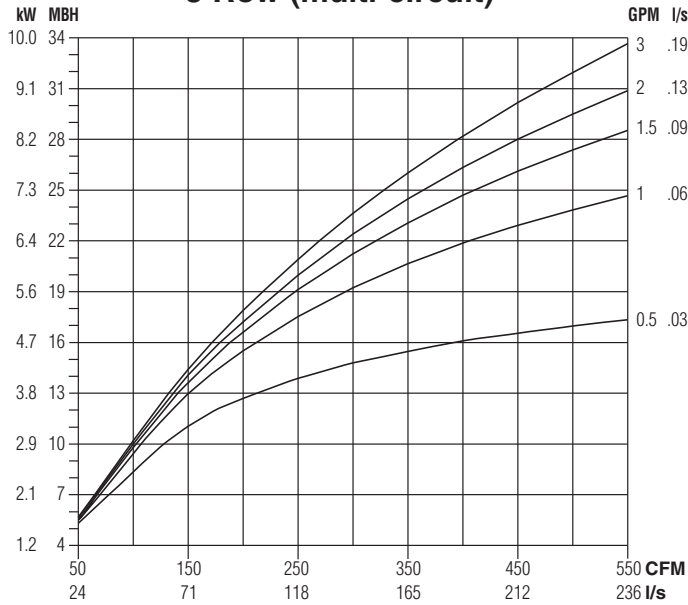

Water Pressure Drop

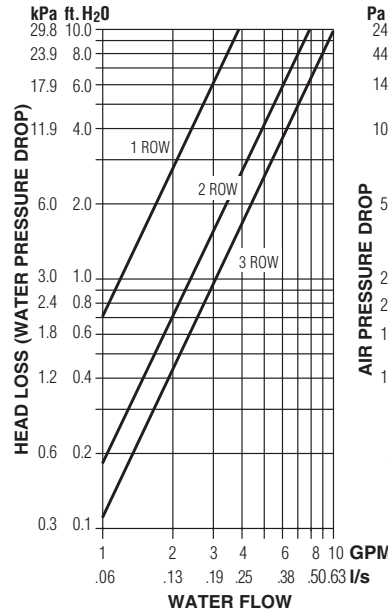

Air Pressure Drop

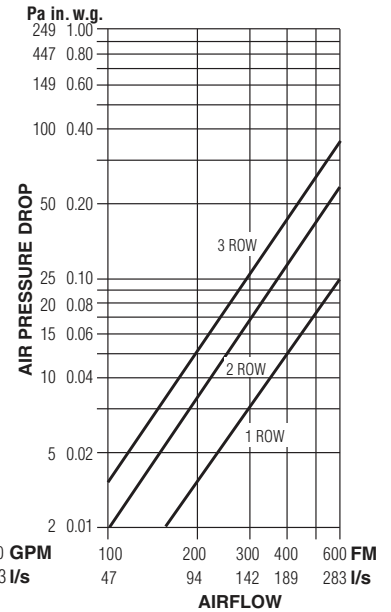

NOTES:

- Capacities are in MBH (kW), **thousands of Btu per hour (kiloWatts)**.
- MBH (kW) values are based on a Δt (temperature difference) of 110°F (61°C) between entering air and entering water. For other Δt 's; multiply the MBH (kW) values by the factors below.

- Air Temperature Rise.

$$\text{ATR (°F)} = 927 \times \frac{\text{MBH}}{\text{cfm}}, \quad \text{ATR (°C)} = 829 \times \frac{\text{kW}}{\text{l/s}}$$

- Water Temp. Drop.

$$\text{WTD (°F)} = 2.04 \times \frac{\text{MBH}}{\text{GPM}}, \quad \text{WTD (°C)} = .224 \times \frac{\text{kW}}{\text{l/s}}$$

- Connections: 1 Row 1/2" (13), 2 and 3 Row 7/8" (22); O.D. male solder.

Altitude Correction Factors:

Altitude ft. (m)	Sensible Heat Factor
0 (0)	1.00
2000 (610)	0.94
3000 (914)	0.90
4000 (1219)	0.87
5000 (1524)	0.84
6000 (1829)	0.81
7000 (2134)	0.78

Correction factors at other entering conditions:

Δt °F (°C)	50 (28)	60 (33)	70 (39)	80 (44)	90 (50)	100 (56)	110 (61)	120 (67)	130 (72)	140 (78)	150 (83)
Factor	.455 (.459)	.545 (.541)	.636 (.639)	.727 (.721)	.818 (.820)	.909 (.918)	1.00 (1.00)	1.09 (1.10)	1.18 (1.18)	1.27 (1.28)	1.36 (1.36)

Performance Data • Hot Water Coil

Models: 37SW and 37SWST • Low Profile • Series Flow

Unit Sizes 2 & 3

1 Row (single circuit)

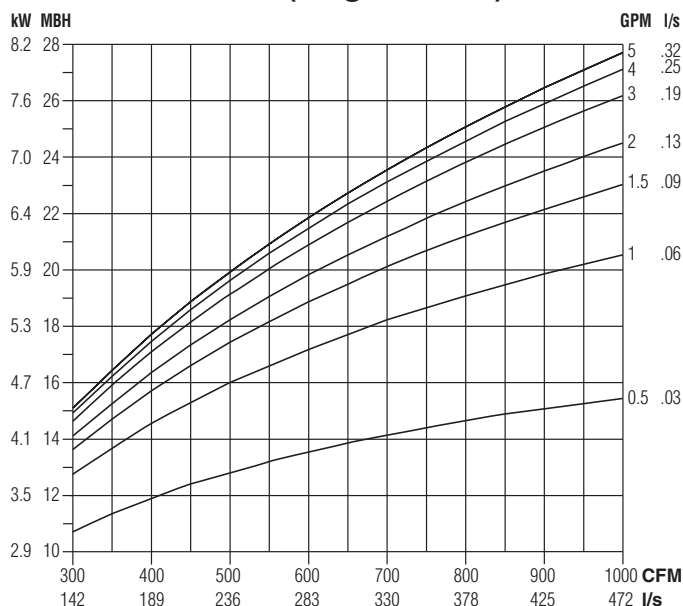

2 Row (multi-circuit)

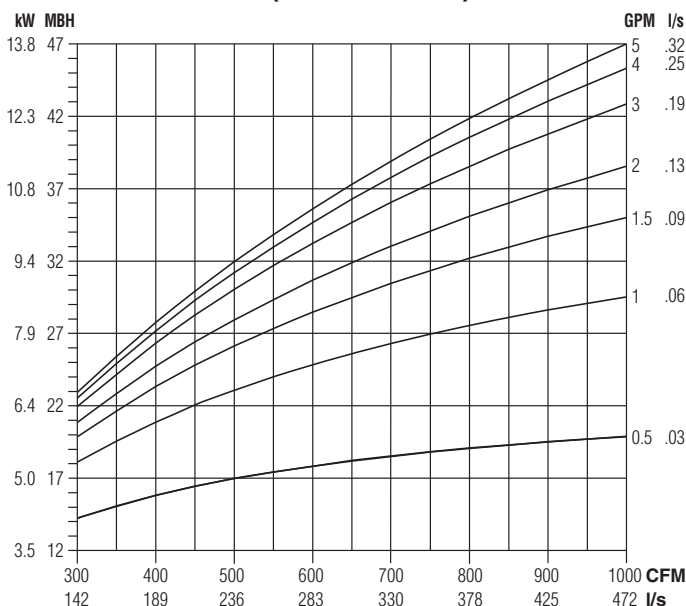

3 Row (multi-circuit)

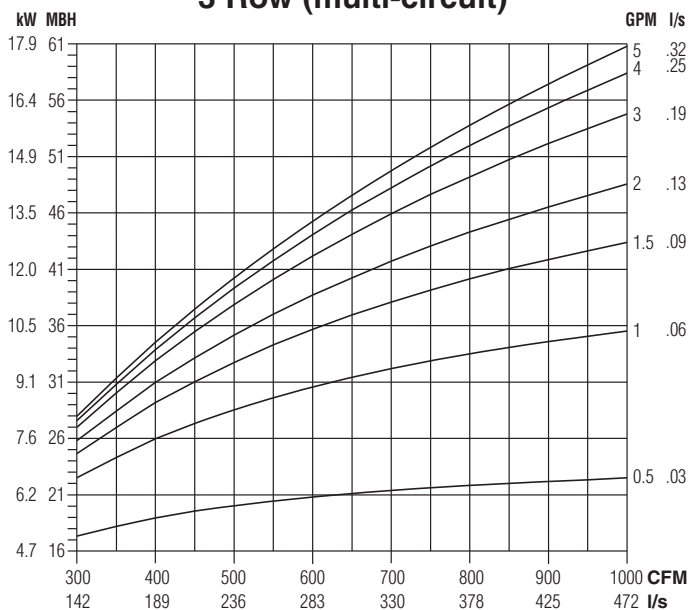

Water Pressure Drop

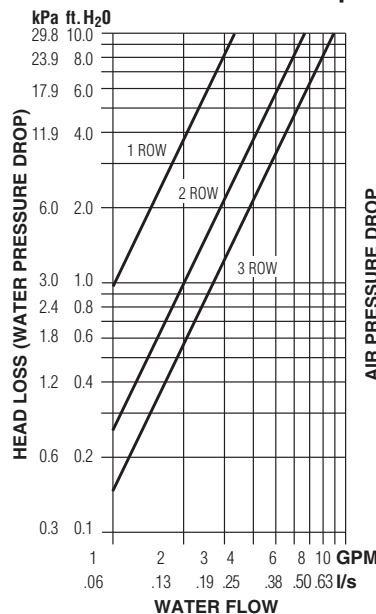

Air Pressure Drop

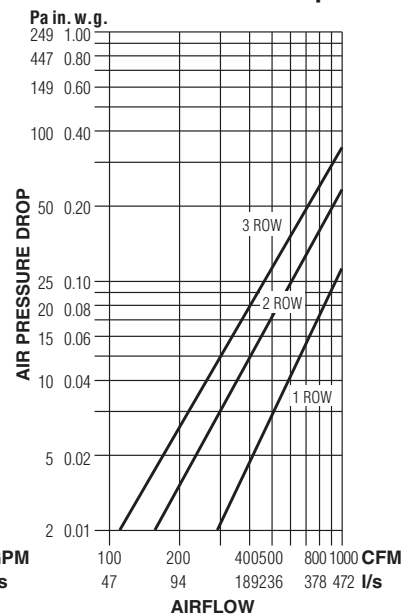

NOTES:

- Capacities are in MBH (kW), **thousands of Btu per hour (kiloWatts)**.
- MBH (kW) values are based on a Δt (temperature difference) of 110°F (61°C) between entering air and entering water. For other Δt 's; multiply the MBH (kW) values by the factors below.

- Air Temperature Rise.
 $ATR (^\circ F) = 927 \times \frac{MBH}{cfm}$, $ATR (^\circ C) = 829 \times \frac{kW}{I/s}$
- Water Temp. Drop.
 $WTD (^\circ F) = 2.04 \times \frac{MBH}{GPM}$, $WTD (^\circ C) = .224 \times \frac{kW}{I/s}$
- Connections: 1 Row 1/2" (13), 2 and 3 Row 7/8" (22); O.D. male solder.

Altitude Correction Factors:

Altitude ft. (m)	Sensible Heat Factor
0 (0)	1.00
2000 (610)	0.94
3000 (914)	0.90
4000 (1219)	0.87
5000 (1524)	0.84
6000 (1829)	0.81
7000 (2134)	0.78

Correction factors at other entering conditions:

Δt °F (°C)	50 (28)	60 (33)	70 (39)	80 (44)	90 (50)	100 (56)	110 (61)	120 (67)	130 (72)	140 (78)	150 (83)
Factor	.455 (.459)	.545 (.541)	.636 (.639)	.727 (.721)	.818 (.820)	.909 (.918)	1.00 (1.00)	1.09 (1.10)	1.18 (1.18)	1.27 (1.28)	1.36 (1.36)

Performance Data • Hot Water Coil

Models: 37SW and 37SWST • Low Profile • Series Flow

Unit Size 4

1 Row (single circuit)

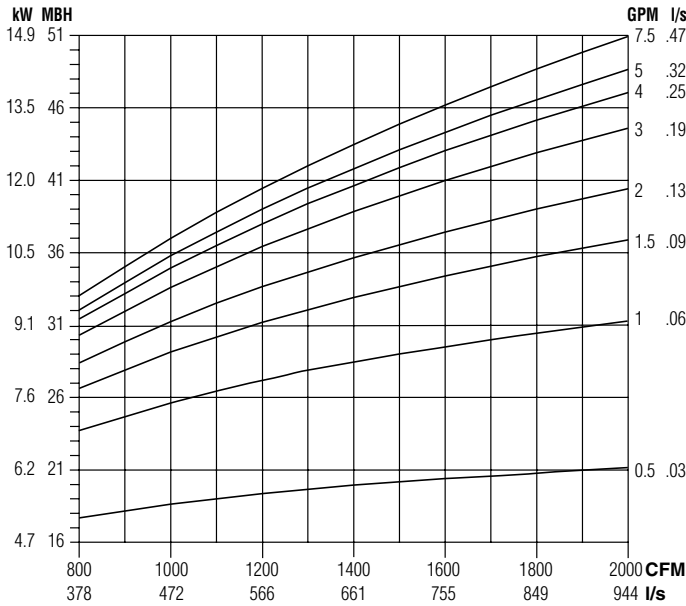

2 Row (multi-circuit)

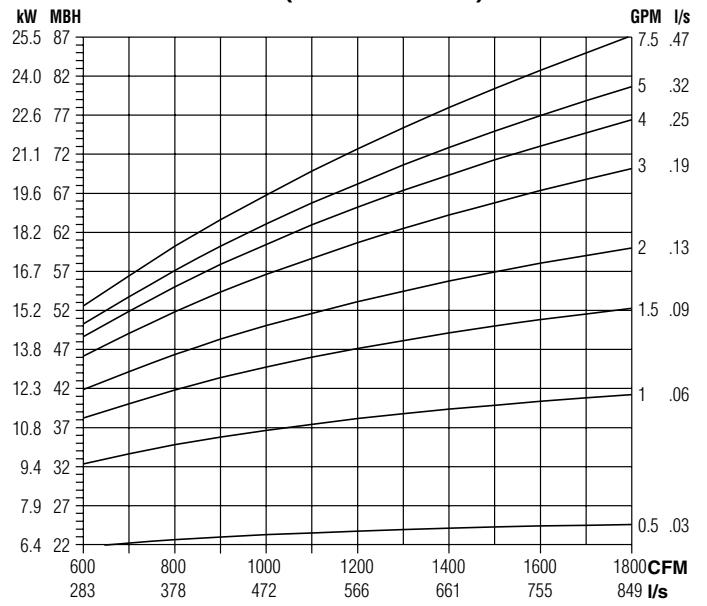

3 Row (multi-circuit)

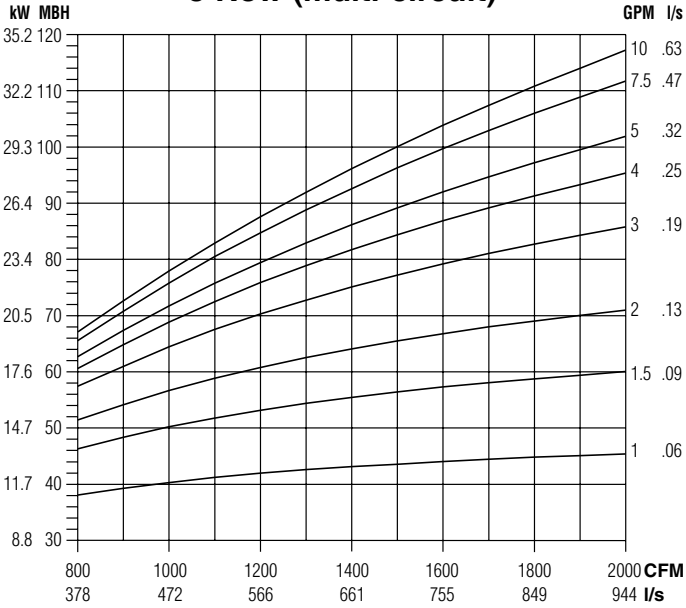

Water Pressure Drop

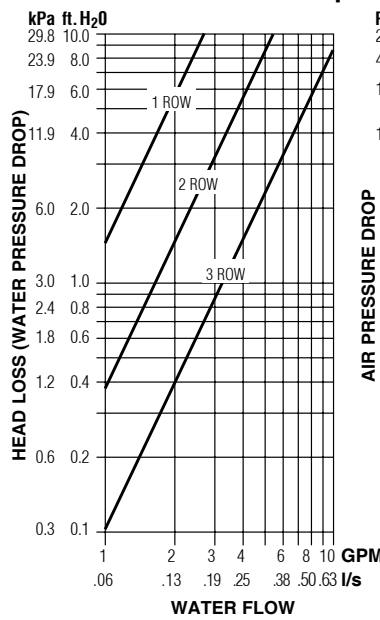

Air Pressure Drop

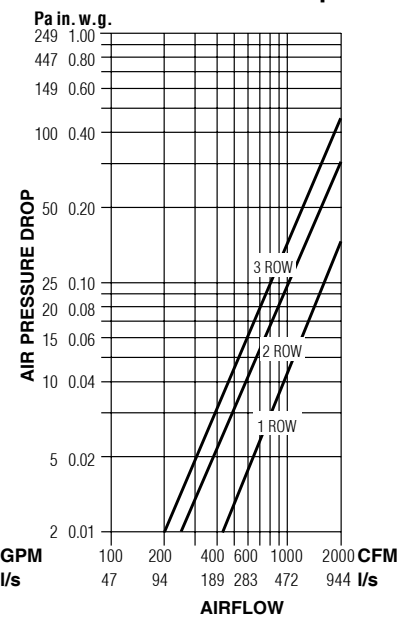

NOTES:

- Capacities are in MBH (kW), *thousands of Btu per hour (kiloWatts)*.
- MBH (kW) values are based on a Δt (temperature difference) of 110°F (61°C) between entering air and entering water. For other Δt 's; multiply the MBH (kW) values by the factors below.

- Air Temperature Rise.
 $ATR (^{\circ}F) = 927 \times \frac{MBH}{cfm}$, $ATR (^{\circ}C) = 829 \times \frac{kW}{l/s}$
- Water Temp. Drop.
 $WTD (^{\circ}F) = 2.04 \times \frac{MBH}{GPM}$, $WTD (^{\circ}C) = .224 \times \frac{kW}{l/s}$
- Connections: 1 Row 1/2" (13), 2 and 3 Row 7/8" (22); O.D. male solder.

Altitude Correction Factors:

Altitude ft. (m)	Sensible Heat Factor
0 (0)	1.00
2000 (610)	0.94
3000 (914)	0.90
4000 (1219)	0.87
5000 (1524)	0.84
6000 (1829)	0.81
7000 (2134)	0.78

Correction factors at other entering conditions:

Δt °F (°C)	50 (28)	60 (33)	70 (39)	80 (44)	90 (50)	100 (56)	110 (61)	120 (67)	130 (72)	140 (78)	150 (83)
Factor	.455 (.459)	.545 (.541)	.636 (.639)	.727 (.721)	.818 (.820)	.909 (.918)	1.00 (1.00)	1.09 (1.10)	1.18 (1.18)	1.27 (1.28)	1.36 (1.36)

Electric Heating Coils

Features, Selection and Capacities

Nailor Electric Coils are tested with terminal units in accordance with UL Standard 1995 and meet all requirements of the NEC (National Electric Code) and CSA (Canadian Standards Association). Units are listed and labeled by the ETL Testing Laboratory as a total package. All controls are enclosed in a NEMA 1 electrical enclosure on the side of the fan package for easy access.

All wiring for the motor and heater terminates in the enclosure for single point electrical connection in the field. Each unit is supplied with a wiring diagram. Note: NEC requires a means to disconnect the heater power supply within sight or on the terminal.

Standard Features:

- Automatic reset high limit thermal cut-outs.
- Magnetic contactors per stage on terminals with DDC or analog electronic controls.
- P.E. switch per stage to carry load or pilot duty with magnetic contactors as required with pneumatic control.
- Positive pressure airflow safety switch.
- P.E. switch for fan on parallel terminals (P35NE) with pneumatic control.
- Fan relay for DDC fan terminals.
- Control voltage transformer (Class II) for DDC or analog electronic terminals.
- Class A 80/20 Ni/Cr wire.

Options:

- Toggle disconnect switch.
- Door interlocking disconnect switch.
- Mercury contactors.
- Power circuit fusing.
- Dust tight control enclosure.
- Manual reset high limits.
- SCR Control.

SCR Control Option:

The SCR (Silicon Controlled Rectifier) option provides infinite solid state heater control using a proportional signal (0 – 10 Vdc or 4 – 20 mA). This option may be specified compatible with pneumatic, analog electronic or digital (DDC) controls.

Time proportional control of the electric heater provides superior comfort and energy savings. The SCR controller modulates the heater to supply the exact amount of heat based upon the zone requirement. Room set points are maintained more accurately, undershoot and overshoot as associated with staged heat are eliminated, reducing operation costs.

SCR controllers provide silent operation, as mechanical staged contactors are eliminated. Zero cross switching of the thyristor prevents electrical noise.

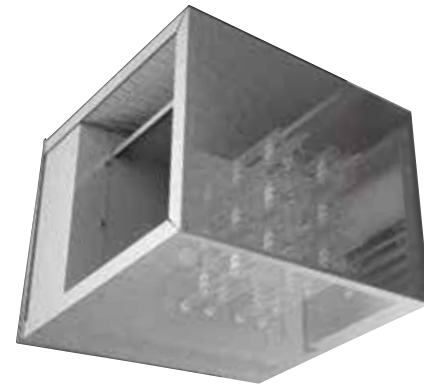

Models	Unit Size	Maximum KiloWatts - 1 Stage Heat				
		120 Volt 1 phase	208/240 Volt 1 phase	277 Volt 1 phase	208 Volt 3 phase	480 & 600 Volt 3 phase
33SZE	30	4.5	10*	11.5	14.5	15
	40	4.5	10*	11.5	14.5	18
	50	4.5	10*	11.5	14.5	25
35SE 35SEST	1	–	8	8	10	8
	2	–	8	8	10	8
	3	–	8	11.5	10	14
	4	–	8	11.5	10	16
	5	–	8	11.5	14.5	20.5
	6	–	8	11.5	14.5	26
	7	–	8	11.5	14.5	30
37SE 37SEST	1	–	5.5	5.5	5.5	5.5
	2	–	10.5**	12	12	12
	3	–	10***	12	15.5	17
	4	–	8	11.5	14.5	27
35NE	2	–	8	8	10	8
	3	–	8	11.5	10	14
	5	–	8	11.5	14.5	20.5
	6	–	8	11.5	14.5	26
37NE	2	–	8	11.5	11.5	11.5
	3	–	8	11.5	13.5	16
	4	–	8	11.5	14.5	27

*208V max is 8.5
 **208V max is 9.0
 ***208V max is 8.5

Recommended Selection:

The table above is a quick reference guide, to illustrate the relationship between electrical power supply, heater capacity in kiloWatts and terminal unit size that are available for fan powered units.

- Digital and pneumatic control terminals are available with up to 3 stages of heat. Analog electronic control terminals are available with 1 or 2 stages of heat only. A minimum of 0.5 kW per stage is required.

- Voltage and kilowatt ratings are sized so as not to exceed 48 amps, in order to avoid the NEC code requirement for circuit fusing.

- A minimum airflow of 70 cfm (33 l/s) per kW is required for any given terminal in order to avoid possible nuisance tripping of the thermal cutouts.

- Discharge air temperature should not exceed 120°F (49°C).



Tested and approved to the following standards:
ANSI/UL 1995, 1st ed.
CSA C22.2 No. 236.

Electric Heating Coils (continued)

Application Guidelines

Discharge Air Temperature

When considering the capacity and airflow for the heater, discharge air temperature can be an important factor. Rooms use different types of diffusers and they are intended to perform different functions. Slots that blend the air at the glass and set up air curtains within the room, must be able to blow the air very low in the room. Hot air will be too buoyant to be effective in this case. Discharge air temperatures for this application should be in the 85 – 90°F (29 – 32°C) range.

Diffusers in the center of the room blend their discharge air as it crosses the ceiling. Discharge air temperatures in this application can be as high as 105°F (41°C) and still be effective. However, if the return air grilles are in the discharge air pattern, the warm air will be returned to the plenum before it heats the room. Again, the air temperature needs to be blended down to an acceptable temperature that can be forced down into the occupied space by the time the air gets to the walls. Discharging warm air into the room at temperatures above 105°F (41°C) usually will set up stratification layers and will not keep the occupants warm if there is a ceiling return because only the top 12" – 24" (300 – 600 mm) of the room will be heated.

The maximum approved discharge air temperature for any Nailor Fan Powered Terminal Unit with supplemental heat is 120°F (49°C). No heater should be applied to exceed this temperature.

Electric Heater Selection

To properly select an electric heater, three things must be determined: the heat requirement for the room, the entering air temperature and the desired discharge air temperature. The heat requirement for the room is the sum of the heat loss calculation and the amount of heat required to raise the entering air temperature to the desired room temperature. Usually, the second item is small compared to the first for fan powered terminal units in a return air plenum. MBH can be converted to kW by using the chart or by calculation. There are 3.413 MBH in 1 kW. If using the chart, find the MBH on the left scale, then move horizontally to the right and read kW.

Next, the desired discharge air temperature should be ascertained. This will depend on the type of diffusers that are in the room.

The desired heating airflow for the room can then be calculated using the following equation:

$$cfm = \frac{kW \times 3160}{\Delta t \text{ (discharge air temp - inlet air temp.) } ^\circ F}$$

Assuming 70°F (21°C) supply air temperature to the heater, the room airflow can be selected directly from the chart. Start at the left at the design kW. Move horizontally to the desired discharge air temperature. Then, move vertically down to the cfm at the bottom of the chart.

The kW can be selected directly from the chart. Start at the bottom with the design cfm into the room. Move vertically up to the line that represents the desired discharge air temperature. Then, move left to the kW.

The discharge air temperature can also be selected directly from the chart. Start at the bottom with the design cfm into the room. Move to the left side of the chart and find the design kW. Move horizontally and vertically into the chart until the lines intersect. The intersection will be the desired discharge air temperature. Interpolation between the curves is linear.

Heater Selection Chart

