

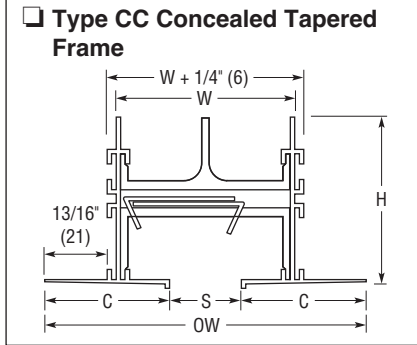

**FLOWLINE™ LINEAR SLOT DIFFUSERS**  
 ARCHITECTURAL • ALUMINUM  
 HORIZONTAL HIGH THROW PATTERN CONTROLLERS  
 MODEL SERIES: FLH TYPES CC, CCA, CCC & CCCA

**CONCEALED SURFACE MOUNT APPLICATION • DRYWALL (CEILING/WALL) TAPE & SPACKLE**

**One Slot**



**Two Slot**

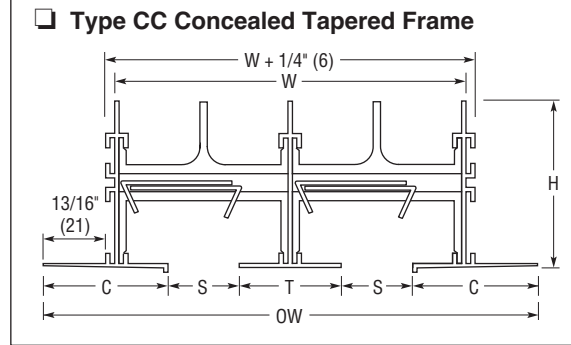

**End Condition**

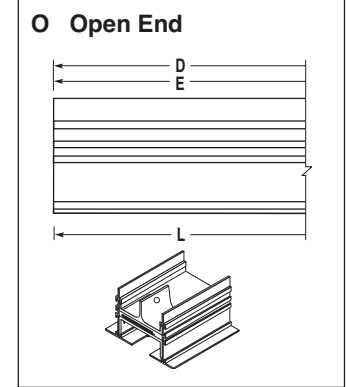
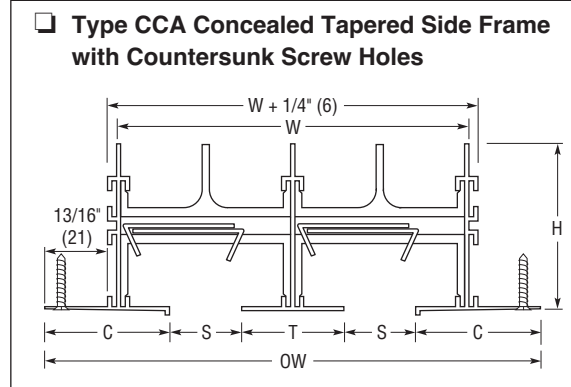
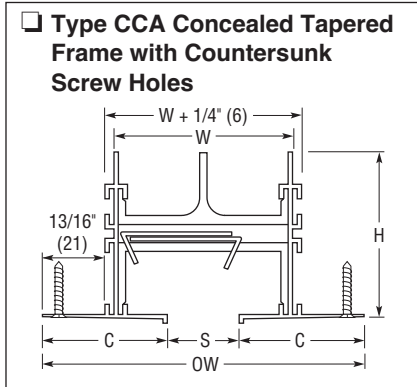
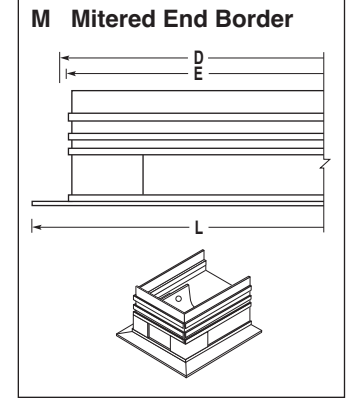

**Dimensional Data - Imperial (Metric) Units**

Model	S Slot Width	1 Slot		2 Slot		C Border Width	H Height	T 2 Slot
		W	OW	W	OW			
FLH10	1 (25)	2 1/2 (64)	4 3/8 (111)	4 15/16 (125)	6 13/16 (173)	1 11/16 (43)	2 3/8 (60)	1 7/16 (37)
FLH15	1 1/2 (38)	3 1/2 (89)	5 3/8 (137)	6 15/16 (176)	8 13/16 (224)	1 15/16 (49)	2 5/8 (67)	1 15/16 (49)
FLH20	2 (51)	4 1/2 (114)	6 3/8 (162)	8 15/16 (227)	10 13/16 (275)	2 3/16 (56)	2 7/8 (73)	2 7/16 (62)
FLH25	2 1/2 (64)	5 1/2 (140)	7 3/8 (187)	10 15/16 (278)	12 13/16 (325)	2 7/16 (62)	3 1/8 (79)	2 15/16 (75)
FLH30	3 (76)	6 1/2 (165)	8 3/8 (213)	12 15/16 (329)	14 13/16 (376)	2 11/16 (68)	3 3/8 (86)	3 7/16 (87)

**Notes:**

- Material: Heavy duty extruded aluminum frame and spacers. Corrosion resistant steel pattern controllers.
- Maximum single section length is 144" (3658). Longer lengths are furnished in multiple sections with alignment strips, the number and size determined by the factory.
- Adjustable pattern controllers are on 24" (610) centers.
- MI Mill finish is standard on frame/border CC with an AW Appliance White center tee on the 2 slot model. Pattern controllers and interior surfaces are black.
- Type CC and CCA have integral hanger brackets on 24" (610) centers. See separate submittal for Type CC optional mounting hardware and accessories.

**Options:**

SP Special Finish \_\_\_\_\_.

**Overall Length and End Cap Position**

	E	L
<input type="checkbox"/> MM	D - 1/4 (6)	D + 1 3/8 (35)
<input type="checkbox"/> MO	D - 1/8 (3)	D + 11/16 (17)
<input type="checkbox"/> MC	D - 1/16 (2)	D + 3/4 (19)
<input type="checkbox"/> OO	D	D
<input type="checkbox"/> OC	D - 1/16 (2)	D - 1/16 (2)
<input type="checkbox"/> CC	D - 1/8 (3)	D - 1/8 (3)

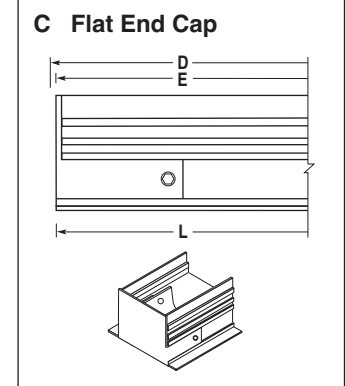

**SCHEDULE TYPE**

**PROJECT**

**ENGINEER**

**CONTRACTOR**

Page 1 of 2  
 Dimensions are in inches (mm).

**DATE**

**B SERIES**

**SUPERSEDES**

**DRAWING NO.**

1 - 19 - 16

FL

10 - 30 - 15

FLH-2A



**FLOWLINE™ LINEAR SLOT DIFFUSERS**  
 ARCHITECTURAL • ALUMINUM  
 HORIZONTAL HIGH THROW PATTERN CONTROLLERS  
 MODEL SERIES: FLH TYPES CC, CCA, CCC & CCCA

**One Slot**

**Type CCC Concealed Tapered Frame with Concealed Mounting Brackets**

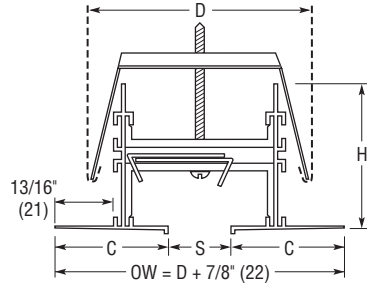

**Two Slot**

**Type CCC Concealed Tapered Side Frame with Concealed Mounting Brackets**

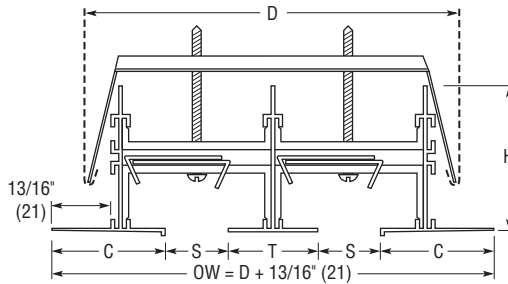

**End Condition**

**M Mitered End Border**

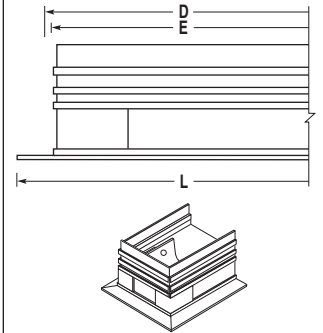

**Type CCCA Concealed Tapered Frame with Concealed Mounting Brackets & Countersunk Screw Holes**

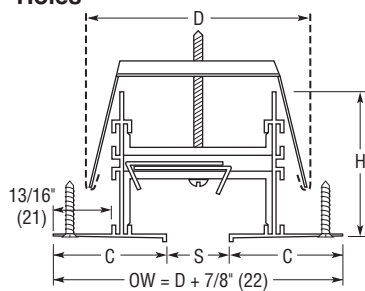

**Type CCCA Concealed Tapered Side Frame with Concealed Mounting Brackets & Countersunk Screw Holes**

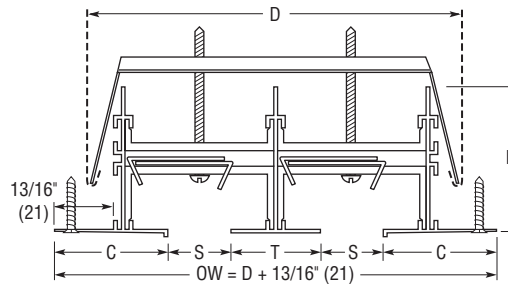

**O Open End**

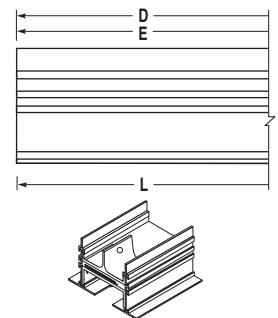

**Dimensional Data - Imperial (Metric) Units**

Model	S Slot Width	D Duct Width		C Border Width	H Height	T 2 Slot	Ceiling Opening Width	
		1 Slot	2 Slot				1 Slot	2 Slot
FLH10	1 (25)	3 1/2 (89)	6 (152)	1 11/16 (43)	2 3/8 (60)	1 7/16 (37)	3 (76)	5 1/2 (140)
FLH15	1 1/2 (38)	4 1/2 (114)	8 (203)	1 15/16 (49)	2 5/8 (67)	1 15/16 (49)	4 (102)	7 1/2 (191)
FLH20	2 (51)	5 1/2 (140)	10 (254)	2 3/16 (56)	2 7/8 (73)	2 7/16 (62)	5 (127)	9 1/2 (241)
FLH25	2 1/2 (64)	6 1/2 (165)	12 (305)	2 7/16 (62)	3 1/8 (79)	2 15/16 (75)	6 (152)	11 1/2 (292)
FLH30	3 (76)	7 1/2 (191)	14 (356)	2 11/16 (68)	3 3/8 (86)	3 7/16 (87)	7 (178)	13 1/2 (343)

**Notes:**

- Material: Heavy duty extruded aluminum frame and spacers. Corrosion resistant steel pattern controllers.
- Maximum single section length is 144" (3658). Longer lengths are furnished in multiple sections with alignment strips, the number and size determined by the factory.
- Adjustable pattern controllers are on 24" (610) centers.
- MI Mill finish is standard on frame/borders CCC and CCCA with an AW Appliance White center tee on the 2 slot model. Pattern controllers and interior surfaces are black.
- Types CCC and CCCA are supplied with concealed mounting brackets and leveling screws on 24" (610) centers. See separate submittal for accessories.

**Options:**

SP Special Finish \_\_\_\_\_.

**Overall Length and End Cap Position**

	E	L
<input type="checkbox"/> MM	D - 1/4 (6)	D + 1 3/8 (35)
<input type="checkbox"/> MO	D - 1/8 (3)	D + 11/16 (17)
<input type="checkbox"/> MC	D - 1/16 (2)	D + 3/4 (19)
<input type="checkbox"/> OO	D	D
<input type="checkbox"/> OC	D - 1/16 (2)	D - 1/16 (2)
<input type="checkbox"/> CC	D - 1/8 (3)	D - 1/8 (3)

**C Flat End Cap**

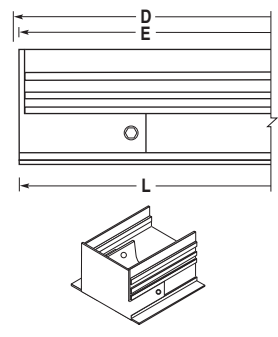

**SCHEDULE TYPE**

**PROJECT**

**ENGINEER**

**CONTRACTOR**

Page 2 of 2  
 Dimensions are in inches (mm).

**DATE**

**B SERIES**

**SUPERSEDES**

**DRAWING NO.**

1 - 19 - 16

FL

10 - 30 - 15

FLH-2A