

LOUVERS



Model 1606JD

Model 1606JD combines the desired foul weather performance of a drainable louver with the pleasing aesthetics of an architectural louver. High performance J style architectural blades, combined with a drainable head that utilizes a top rain gutter with concealed downspouts in the side frame, prevent cascading water running down the building's face from entering into the airstream during light to moderate rain conditions. The blade design features a rear water baffle, with low pressure drop characteristics and a high free area. Reinforcing bosses run the full length of each blade for superior strength. Suitable for use in ventilation, exhaust and low to medium velocity intake applications where water penetration is a concern. Available in channel, flanged, or glazing adaptor type, the 6" (152) deep frame installs easily in most common wall configurations. Model 1606JD is AMCA Licensed for Water Penetration and Air Performance.

STANDARD CONSTRUCTION:

Frame:	6" (152) deep, Type 6063-T5 extruded aluminum, .080" (2.03) nominal wall thickness. Integral caulking slot provided.
Blades:	Type 6063-T5 extruded aluminum, .080" (2.03) nominal wall thickness, with reinforcing bosses. J style.
Blade Angle:	Fixed at 37 degrees.
Blade Spacing:	Approximately 6" (152) on centers.
Blade Support Brackets:	Concealed type, factory installed on rear of louver on maximum 60" (1524) centers. Reinforced with 1 1/2" x 2" (38 x 51) angle (adds approx. 2" [51] to overall louver depth).
Mullions:	Concealed type allowing continuous line appearance up to 120" (3048) wide. Larger assemblies require separate visible frames with downspouts.
Screen:	3/4" x .051 (19 x 1.3) expanded, flattened aluminum bird screen in removable frame, inside (rear) mount (adds approximately 3/8" [10] to louver depth).
Finish:	Mill.
Minimum Size:	12" W x 12" H (305 x 305).
Maximum Single Section Size:	120" W x 84" H (3048 x 2134) or 84" W x 120" H (2134 x 3048). 70 sq. ft. (6.5 m ²). Larger louvers will require field assembly of smaller sections.

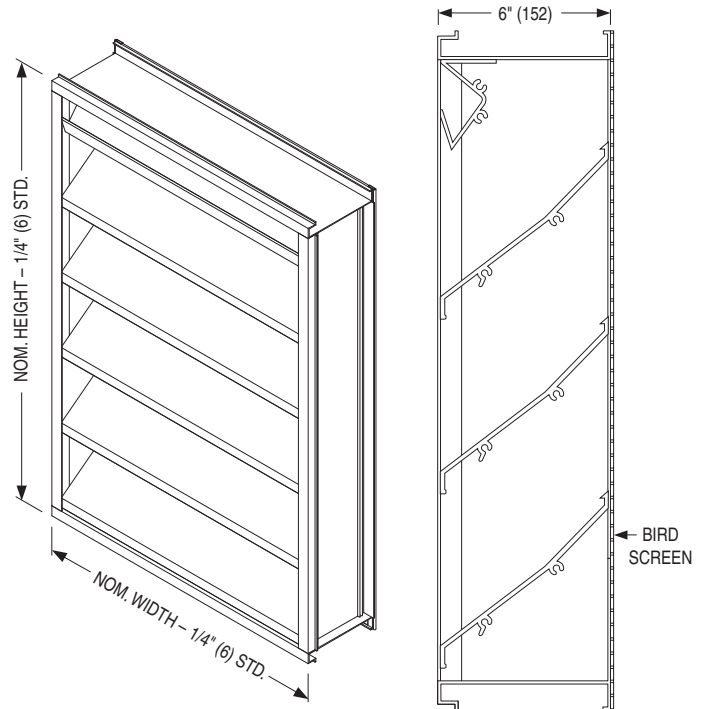

MODEL 1606JD

COMMON OPTIONS:

- Flanged or Glazing Adaptor Frame styles.
- Aluminum or Type 304 Stainless Steel Insect Screens.
- Extended Sills.
- Aluminum Installation Clips or Continuous Angles.
- Variety of Standard and High Performance Powder Coat finishes available in a multitude of colors. Custom color matching available.
- Clear or Color Anodized finishes.



PERFORMANCE DATA:

MODEL: 1604JD

FREE AREA in Square Feet and Square Meters

LOUVERS

		Width in Inches and Meters																		
		12	18	24	30	36	42	48	54	60	66	72	78	84	90	96	102	108	114	120
Height in Inches and Meters	12	0.25	0.39	0.54	0.69	0.84	0.99	1.14	1.29	1.44	1.59	1.74	1.89	2.04	2.19	2.34	2.49	2.64	2.79	2.94
	.30	0.02	0.03	0.05	0.06	0.07	0.09	0.10	0.12	0.13	0.14	0.16	0.17	0.19	0.20	0.21	0.22	0.25	0.26	0.27
	18	0.52	0.83	1.14	1.46	1.77	2.09	2.40	2.71	3.03	3.34	3.65	3.97	4.28	4.59	4.91	5.22	5.53	5.85	6.16
	.46	0.05	0.07	0.10	0.13	0.16	0.19	0.22	0.25	0.28	0.31	0.34	0.36	0.39	0.42	0.45	0.49	0.51	0.54	0.57
	24	0.80	1.28	1.77	2.25	2.73	3.22	3.70	4.19	4.67	5.15	5.64	6.12	6.60	7.09	7.57	8.05	8.54	9.02	9.50
	.61	0.07	0.12	0.16	0.21	0.25	0.29	0.34	0.38	0.43	0.47	0.52	0.56	0.61	0.65	0.70	0.75	0.79	0.84	0.88
	30	1.04	1.67	2.30	2.93	3.56	4.19	4.82	5.45	6.08	6.71	7.34	7.97	8.60	9.23	9.86	10.49	11.12	11.75	12.38
	.76	0.09	0.15	0.21	0.27	0.33	0.39	0.44	0.50	0.56	0.62	0.68	0.74	0.79	0.85	0.91	0.98	1.03	1.09	1.15
	36	1.33	2.13	2.93	3.73	4.53	5.33	6.13	6.93	7.73	8.53	9.33	10.13	10.93	11.73	12.53	13.33	14.13	14.93	15.73
	.91	0.12	0.19	0.27	0.34	0.42	0.49	0.57	0.64	0.71	0.79	0.86	0.94	1.01	1.09	1.16	1.24	1.31	1.39	1.46
	42	1.58	2.52	3.47	4.42	5.37	6.32	7.27	8.22	9.16	10.11	11.06	12.01	12.96	13.91	14.86	15.81	16.76	17.71	18.66
	1.07	0.14	0.23	0.32	0.41	0.49	0.58	0.67	0.76	0.85	0.94	1.02	1.11	1.20	1.29	1.38	1.47	1.56	1.65	1.73
	48	1.85	2.97	4.09	5.20	6.32	7.43	8.57	9.66	10.78	11.89	13.01	14.12	15.24	16.35	17.47	18.58	19.70	20.81	21.93
	1.22	0.17	0.27	0.38	0.48	0.58	0.69	0.80	0.89	1.00	1.10	1.20	1.31	1.41	1.52	1.62	1.73	1.83	1.93	2.04
	54	2.11	3.38	4.64	5.91	7.18	8.44	9.71	10.98	12.25	13.51	14.78	16.05	17.32	18.58	19.85	21.12	22.38	23.64	24.91
	1.37	0.19	0.31	0.43	0.54	0.66	0.78	0.90	1.02	1.13	1.25	1.37	1.49	1.60	1.72	1.84	1.96	2.08	2.20	2.32
	60	2.38	3.81	5.25	6.68	8.11	9.54	10.97	12.41	13.84	15.27	16.70	18.13	19.57	21.00	22.43	23.86	25.29	26.73	28.16
	1.52	0.22	0.35	0.48	0.62	0.75	0.88	1.02	1.15	1.28	1.41	1.55	1.68	1.81	1.95	2.08	2.22	2.35	2.48	2.62
	66	2.67	4.27	5.87	7.47	9.08	10.68	12.28	13.88	15.48	17.09	18.69	20.29	21.89	23.50	25.10	26.70	28.30	29.91	31.51
	1.68	0.24	0.39	0.54	0.69	0.84	0.99	1.14	1.29	1.43	1.58	1.73	1.88	2.03	2.18	2.33	2.48	2.63	2.78	2.93
72	2.91	4.66	6.41	8.16	9.91	11.66	13.41	15.16	16.91	18.66	20.41	22.16	23.91	25.66	27.41	29.16	30.91	32.66	34.41	
1.83	0.27	0.43	0.59	0.75	0.92	1.08	1.24	1.40	1.57	1.73	1.89	2.05	2.22	2.38	2.54	2.71	2.87	3.03	3.20	
78	3.19	5.11	7.03	8.94	10.86	12.78	14.70	16.62	18.53	20.45	22.37	24.29	26.20	28.12	30.04	31.96	33.87	35.79	37.71	
1.98	0.29	0.47	0.65	0.83	1.01	1.18	1.36	1.54	1.72	1.90	2.07	2.25	2.43	2.61	2.79	2.97	3.15	3.33	3.50	
84	3.45	5.52	7.59	9.65	11.72	13.79	15.86	17.93	20.00	22.07	24.14	26.21	28.28	30.35	32.42	34.49	36.56	38.63	40.70	
2.13	0.32	0.51	0.70	0.89	1.09	1.28	1.47	1.66	1.85	2.05	2.24	2.43	2.62	2.82	3.01	3.21	3.40	3.59	3.78	
90	3.72	5.95	8.19	10.42	12.66	14.89	17.13	19.36	21.60	23.83	26.06	28.30	30.53	32.77	35.00	37.24	39.47	41.71	43.94	
2.29	0.34	0.55	0.76	0.96	1.17	1.38	1.59	1.79	2.00	2.21	2.42	2.62	2.83	3.04	3.25	3.46	3.67	3.88	4.08	
96	4.00	6.41	8.81	11.22	13.62	16.03	18.43	20.84	23.24	25.65	28.05	30.46	32.86	35.27	37.67	40.07	42.48	44.88	47.28	
2.44	0.37	0.59	0.81	1.04	1.26	1.48	1.71	1.93	2.16	2.38	2.60	2.83	3.05	3.27	3.50	3.72	3.95	4.16	4.39	
102	4.30	6.88	9.46	12.04	14.61	17.19	19.77	22.35	24.93	27.51	30.09	32.67	35.25	37.82	40.40	42.98	45.56	48.14	50.72	
2.59	0.40	0.64	0.88	1.12	1.36	1.60	1.84	2.08	2.32	2.56	2.80	3.03	3.27	3.51	3.75	3.99	4.23	4.47	4.71	
108	4.54	7.26	9.98	12.71	15.43	18.15	20.88	23.60	26.32	29.04	31.77	34.49	37.21	39.94	42.66	45.38	48.10	50.83	53.55	
2.74	0.42	0.67	0.93	1.18	1.43	1.69	1.94	2.19	2.45	2.70	2.95	3.20	3.46	3.71	3.96	4.22	4.47	4.72	4.97	
114	4.82	7.72	10.61	13.51	16.40	19.30	22.19	25.09	27.98	30.88	33.77	36.67	39.56	42.46	45.35	48.24	51.14	54.03	56.93	
2.90	0.45	0.72	0.99	1.25	1.52	1.79	2.06	2.33	2.60	2.87	3.14	3.41	3.68	3.94	4.21	4.48	4.75	5.02	5.29	
120	5.06	8.10	11.14	14.18	17.21	20.25	23.29	26.33	29.37	32.40	35.44	38.48	41.52	44.55	47.59	50.63	53.67	56.71	59.74	
3.05	0.47	0.75	1.03	1.32	1.60	1.88	2.16	2.45	2.73	3.01	3.29	3.57	3.86	4.14	4.42	4.70	4.99	5.27	5.55	

AIRFLOW/WATER PENETRATION DATA for 48" x 48" (1219 x 1219) Louver Size

Model	1604JD	
Free Area %	54%	
Free Area sq. ft. (sq. m.)	8.57 (0.80)	
INTAKE	Free Area Velocity at Point of Beginning Water Penetration at .01 oz./sq. ft. (3 ml/sq. m) (15 min. test duration)	961 fpm (293 m/min.)
	Air Volume at Free Area Velocity shown	8236 cfm (3887 l/s)
	Pressure Drop at Free Area Velocity shown	.16 in. w.g. (40 Pa)

NOTE: To minimize water penetration when sizing intake louvers, select a Free Area Velocity that is **below** the point of beginning water penetration.



Nailor Industries Inc. certifies the Model 1604JD, shown herein is licensed to bear the AMCA Seal. The ratings shown are based on tests and procedures performed in accordance with AMCA Publication 511 and comply with the requirements of the AMCA Certified Ratings Program. The AMCA Certified Ratings Seal applies to Air Performance and Water Penetration ratings.

PRESSURE DROP

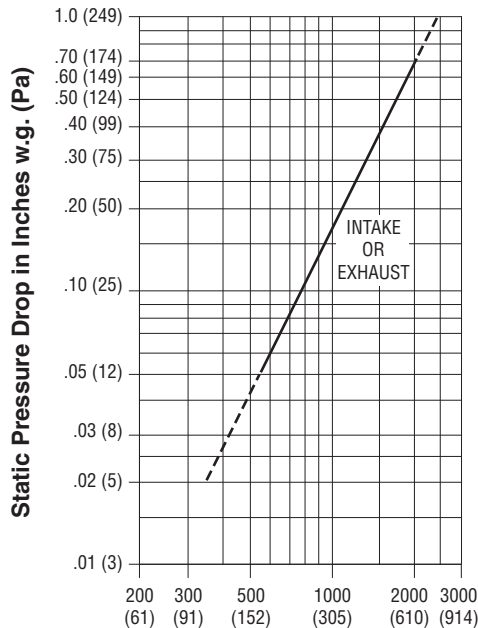

Air Velocity in Feet (Meters) Per Minute Through Free Area
Louver test size: 48" x 48" (1219 x 1219 mm).
Standard air density @ 0.075 lbs/ft³.
Tested to AMCA Fig. 5.5 – 6.5.

PERFORMANCE DATA:**MODEL: 1606JD****FREE AREA in Square Feet and Square Meters**

		Width in Inches and Meters																			
		12	18	24	30	36	42	48	54	60	66	72	78	84	90	96	102	108	114	120	
Height in Inches and Meters	12	0.30	0.46	0.61	0.76	0.91	1.07	1.22	1.37	1.52	1.68	1.83	1.98	2.13	2.29	2.44	2.59	2.74	2.90	3.05	
	0.30	0.11	0.18	0.25	0.32	0.38	0.45	0.52	0.59	0.66	0.73	0.80	0.86	0.93	1.00	1.07	1.14	1.21	1.28	1.34	
	18	0.46	0.04	0.06	0.09	0.11	0.13	0.16	0.18	0.20	0.23	0.25	0.28	0.30	0.32	0.35	0.37	0.39	0.42	0.44	0.47
	0.46	0.04	0.06	0.09	0.11	0.13	0.16	0.18	0.20	0.23	0.25	0.28	0.30	0.32	0.35	0.37	0.39	0.42	0.44	0.47	
	24	0.61	0.06	0.10	0.14	0.18	0.21	0.25	0.29	0.33	0.37	0.41	0.44	0.48	0.52	0.56	0.60	0.63	0.67	0.71	0.75
	0.61	0.06	0.10	0.14	0.18	0.21	0.25	0.29	0.33	0.37	0.41	0.44	0.48	0.52	0.56	0.60	0.63	0.67	0.71	0.75	
	30	0.76	0.09	0.15	0.21	0.27	0.33	0.39	0.44	0.50	0.56	0.62	0.68	0.74	0.80	0.85	0.91	0.97	1.03	1.09	1.15
	0.76	0.09	0.15	0.21	0.27	0.33	0.39	0.44	0.50	0.56	0.62	0.68	0.74	0.80	0.85	0.91	0.97	1.03	1.09	1.15	
	36	0.91	0.12	0.19	0.26	0.34	0.41	0.48	0.55	0.63	0.70	0.77	0.85	0.92	0.99	1.07	1.14	1.21	1.28	1.36	1.43
	0.91	0.12	0.19	0.26	0.34	0.41	0.48	0.55	0.63	0.70	0.77	0.85	0.92	0.99	1.07	1.14	1.21	1.28	1.36	1.43	
	42	1.07	0.14	0.23	0.32	0.41	0.49	0.58	0.67	0.76	0.85	0.93	1.02	1.11	1.20	1.29	1.37	1.46	1.55	1.64	1.73
	1.07	0.14	0.23	0.32	0.41	0.49	0.58	0.67	0.76	0.85	0.93	1.02	1.11	1.20	1.29	1.37	1.46	1.55	1.64	1.73	
	48	1.22	0.16	0.25	0.35	0.45	0.54	0.64	0.69	0.78	0.87	0.97	1.06	1.15	1.24	1.33	1.42	1.51	1.60	1.69	1.78
	1.22	0.16	0.25	0.35	0.45	0.54	0.64	0.69	0.78	0.87	0.97	1.06	1.15	1.24	1.33	1.42	1.51	1.60	1.69	1.78	
	54	1.37	0.19	0.31	0.42	0.54	0.66	0.78	0.89	1.01	1.13	1.25	1.36	1.48	1.60	1.72	1.83	1.95	2.07	2.19	2.30
	1.37	0.19	0.31	0.42	0.54	0.66	0.78	0.89	1.01	1.13	1.25	1.36	1.48	1.60	1.72	1.83	1.95	2.07	2.19	2.30	
	60	1.52	0.21	0.35	0.48	0.61	0.74	0.88	1.01	1.14	1.27	1.41	1.54	1.67	1.80	1.94	2.07	2.20	2.33	2.47	2.60
	1.52	0.21	0.35	0.48	0.61	0.74	0.88	1.01	1.14	1.27	1.41	1.54	1.67	1.80	1.94	2.07	2.20	2.33	2.47	2.60	
	66	1.68	0.24	0.38	0.53	0.68	0.83	0.98	1.12	1.27	1.42	1.57	1.71	1.86	2.01	2.16	2.30	2.45	2.60	2.75	2.90
	1.68	0.24	0.38	0.53	0.68	0.83	0.98	1.12	1.27	1.42	1.57	1.71	1.86	2.01	2.16	2.30	2.45	2.60	2.75	2.90	
72	1.83	0.26	0.42	0.59	0.75	0.91	1.07	1.24	1.40	1.56	1.73	1.89	2.05	2.21	2.38	2.54	2.70	2.86	3.03	3.19	
1.83	0.26	0.42	0.59	0.75	0.91	1.07	1.24	1.40	1.56	1.73	1.89	2.05	2.21	2.38	2.54	2.70	2.86	3.03	3.19		
78	1.98	0.28	0.46	0.64	0.82	0.99	1.17	1.35	1.52	1.70	1.88	2.06	2.23	2.41	2.59	2.77	2.94	3.12	3.30	3.47	
1.98	0.28	0.46	0.64	0.82	0.99	1.17	1.35	1.52	1.70	1.88	2.06	2.23	2.41	2.59	2.77	2.94	3.12	3.30	3.47		
84	2.13	0.31	0.50	0.69	0.88	1.07	1.27	1.46	1.65	1.84	2.03	2.22	2.42	2.61	2.80	2.99	3.18	3.37	3.57	3.76	
2.13	0.31	0.50	0.69	0.88	1.07	1.27	1.46	1.65	1.84	2.03	2.22	2.42	2.61	2.80	2.99	3.18	3.37	3.57	3.76		
90	2.29	0.33	0.54	0.75	0.95	1.16	1.37	1.57	1.78	1.99	2.19	2.40	2.61	2.81	3.02	3.23	3.43	3.64	3.85	4.05	
2.29	0.33	0.54	0.75	0.95	1.16	1.37	1.57	1.78	1.99	2.19	2.40	2.61	2.81	3.02	3.23	3.43	3.64	3.85	4.05		
96	2.44	0.36	0.58	0.80	1.02	1.25	1.47	1.69	1.91	2.14	2.36	2.58	2.80	3.03	3.25	3.47	3.69	3.91	4.14	4.36	
2.44	0.36	0.58	0.80	1.02	1.25	1.47	1.69	1.91	2.14	2.36	2.58	2.80	3.03	3.25	3.47	3.69	3.91	4.14	4.36		
102	2.59	0.38	0.62	0.85	1.09	1.33	1.56	1.80	2.04	2.27	2.51	2.75	2.99	3.22	3.46	3.70	3.94	4.17	4.41	4.64	
2.59	0.38	0.62	0.85	1.09	1.33	1.56	1.80	2.04	2.27	2.51	2.75	2.99	3.22	3.46	3.70	3.94	4.17	4.41	4.64		
108	2.74	0.40	0.66	0.91	1.16	1.41	1.66	1.92	2.17	2.42	2.67	2.92	3.18	3.43	3.68	3.93	4.18	4.43	4.69	4.94	
2.74	0.40	0.66	0.91	1.16	1.41	1.66	1.92	2.17	2.42	2.67	2.92	3.18	3.43	3.68	3.93	4.18	4.43	4.69	4.94		
114	2.90	0.43	0.69	0.96	1.23	1.49	1.76	2.03	2.29	2.56	2.82	3.09	3.36	3.62	3.89	4.16	4.42	4.69	4.96	5.22	
2.90	0.43	0.69	0.96	1.23	1.49	1.76	2.03	2.29	2.56	2.82	3.09	3.36	3.62	3.89	4.16	4.42	4.69	4.96	5.22		
120	3.05	0.45	0.73	1.01	1.29	1.57	1.85	2.14	2.42	2.70	2.98	3.26	3.54	3.82	4.10	4.38	4.66	4.94	5.23	5.51	
3.05	0.45	0.73	1.01	1.29	1.57	1.85	2.14	2.42	2.70	2.98	3.26	3.54	3.82	4.10	4.38	4.66	4.94	5.23	5.51		

AIRFLOW/WATER PENETRATION DATA**for 48" x 48" (1219 x 1219) Louver Size**

Model		1606JD
Free Area %		47%
Free Area sq. ft. (sq. m.)		7.45 (0.69)
I N T A K E	Free Area Velocity at Point of Beginning Water Penetration at .01 oz./sq. ft. (3 ml/sq. m) (15 min. test duration)	1250 fpm (381 m/min.)
	Air Volume at Free Area Velocity shown	9313 cfm (4395 l/s)
	Pressure Drop at Free Area Velocity shown	.21 in. w.g. (52 Pa)

NOTE: To minimize water penetration when sizing intake louvers, select a Free Area Velocity that is **below** the point of beginning water penetration.

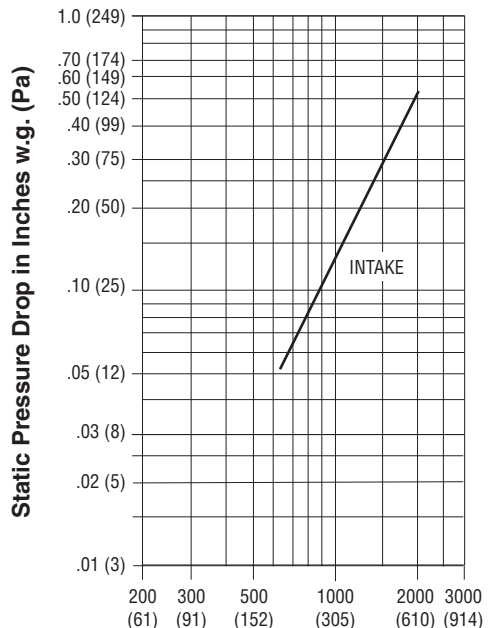

Nailor Industries Inc. certifies the Model 1606JD, shown herein is licensed to bear the AMCA Seal. The ratings shown are based on tests and procedures performed in accordance with AMCA Publication 511 and comply with the requirements of the AMCA Certified Ratings Program. The AMCA Certified Ratings Seal applies to Air Performance and Water Penetration ratings.

PRESSURE DROP**Air Velocity in Feet (Meters) Per Minute Through Free Area**

Louver test size: 48" x 48" (1219 x 1219 mm).

Standard air density @ 0.075 lbs/ft³.

Tested to AMCA Fig. 5.5 - 6.5.

HOW TO SPECIFY

MODEL 1604JD

EXTRUDED ALUMINUM DRAINABLE HEAD LOUVERS

SUGGESTED SPECIFICATION:

Provide and install, as shown on plans and/or schedules, extruded aluminum louvers meeting or exceeding the following criteria: Frame shall be 4" (102) deep channel type (**or specifier to select:** flanged type **or** glazing adapter type), 1/4" (6.3) undersize (**or specifier to select:** exact size **or** 3/8" [9.5] undersize **or** 1/2" [12.7] undersize), with integral caulking slots (and **specifier to select, if required:** extended sill), constructed from ASTM B211 Alloy 6063-T5 extruded aluminum of .080" (2.03) nominal wall thickness. Blades shall be stationary J style, constructed from type 6063-T5 extruded aluminum of .080" (2.03) nominal wall thickness with reinforcing bosses, fixed at 37 degrees on approximately 4" (102) centers and shall be supported by angle reinforced concealed brackets as required to withstand a wind force of not less than 25 pounds per square foot (100 miles per hour). Drain gutter in head frame. Concealed downspouts in jambs to drain water from louver for minimum water cascade from blade to blade. Factory assembled louver components to be mechanically fastened (**or specifier to select:** welded construction). Concealed type mullions for louvers up to 120" (3048) wide allowing continuous line appearance. Large louvers that require multiple sections for shipping shall be constructed with visible frames with downspouts when installed together on site. Louvers shall be equipped with removable 3/4" x .051 (19 x 1.3) expanded, flattened aluminum bird screen (**or specifier to select:** type 304 stainless steel bird screen **and/or** aluminum insect screen **and/or** type 304 stainless steel insect screen **or** no screen).

Finish shall be standard mill (**or specifier to select:** prime coat **or** 204-R1 clear anodized to a min. depth of 0.4 mil, with 1 year warranty **or** 215-R1 clear anodized to a min. depth of 0.7 mil, with 5 year warranty **or** color anodized; color to be selected from standard Nailor anodizing colors **or** AAMA 2603 thermosetting polyester powder coat, with 1 year warranty; color to be (**specifier to select:** selected from Nailor standard color chart **or** custom color) **or** AAMA 2604 high performance polyester powder coat, with 5 year warranty; color to be (**specifier to select:** selected from Nailor standard color chart **or** custom color) **or** AAMA 2605 FEVE fluoropolymer powder coat, with 10 year warranty; color to be (**specifier to select:** selected from Nailor standard color chart **or** custom color) **or** Kynar 500/Hylar 5000 70% PVDF coating, with 5 year warranty; color to be (**specifier to select:** selected from Nailor standard color chart **or** custom color) **or** Kynar 500/Hylar 5000 50% PVDF coating, with 10 year warranty; color to be (**specifier to select:** selected from Nailor standard color chart **or** custom color).

Furnish where indicated on plans and/or schedules, blank-off panels fabricated by the louver manufacturer. Blank-off panels to be 0.040" (1.02) thick aluminum sheet (**or specifier to select:** 0.040" [1.02] thick aluminum sheet with 1" [25] insulation **or** 0.040" [1.02] thick aluminum sheet with 2" [51] insulation **or** 20 ga. [1.0] galvanized steel **or** 20 ga. [1.0] galvanized steel with 1" [25] insulation **or** 20 ga. [1.0] galvanized steel with 2" [51] insulation). Blank-off panels to be finished to match louvers.

Performance data must be licensed by AMCA under the AMCA Certified Ratings Program and shall bear the AMCA Certified Ratings seal for water penetration and air performance. Free area, water penetration and pressure drop data submitted shall be equal to or better than specified model. Standard of acceptance: Nailor Industries, Inc. Model 1604JD.

MODEL 1606JD

EXTRUDED ALUMINUM DRAINABLE HEAD LOUVERS

SUGGESTED SPECIFICATION:

Provide and install, as shown on plans and/or schedules, extruded aluminum louvers meeting or exceeding the following criteria: Frame shall be 6" (152) deep channel type (**or specifier to select:** flanged type **or** glazing adapter type), 1/4" (6.3) undersize (**or specifier to select:** exact size **or** 3/8" [9.5] undersize **or** 1/2" [12.7] undersize), with integral caulking slots (and **specifier to select, if required:** extended sill), constructed from ASTM B211 Alloy 6063-T5 extruded aluminum of .080" (2.03) nominal wall thickness. Blades shall be stationary J style, constructed from type 6063-T5 extruded aluminum of .080" (2.03) nominal wall thickness with reinforcing bosses, fixed at 37 degrees on approximately 6" (152) centers and shall be supported by angle reinforced concealed brackets as required to withstand a wind force of not less than 25 pounds per square foot (100 miles per hour). Drain gutter in head frame. Concealed downspouts in jambs to drain water from louver for minimum water cascade from blade to blade. Factory assembled louver components to be mechanically fastened (**or specifier to select:** welded construction). Concealed type mullions for louvers up to 120" (3048) wide allowing continuous line appearance. Large louvers that require multiple sections for shipping shall be constructed with visible frames with downspouts when installed together on site. Louvers shall be equipped with removable 3/4" x .051 (19 x 1.3) expanded, flattened aluminum bird screen (**or specifier to select:** type 304 stainless steel bird screen **and/or** aluminum insect screen **and/or** type 304 stainless steel insect screen **or** no screen).

Finish shall be standard mill (**or specifier to select:** prime coat **or** 204-R1 clear anodized to a min. depth of 0.4 mil, with 1 year warranty **or** 215-R1 clear anodized to a min. depth of 0.7 mil, with 5 year warranty **or** color anodized; color to be selected from standard Nailor anodizing colors **or** AAMA 2603 thermosetting polyester powder coat, with 1 year warranty; color to be (**specifier to select:** selected from Nailor standard color chart **or** custom color) **or** AAMA 2604 high performance polyester powder coat, with 5 year warranty; color to be (**specifier to select:** selected from Nailor standard color chart **or** custom color) **or** AAMA 2605 FEVE fluoropolymer powder coat, with 10 year warranty; color to be (**specifier to select:** selected from Nailor standard color chart **or** custom color) **or** Kynar 500/Hylar 5000 70% PVDF coating, with 5 year warranty; color to be (**specifier to select:** selected from Nailor standard color chart **or** custom color) **or** Kynar 500/Hylar 5000 50% PVDF coating, with 10 year warranty; color to be (**specifier to select:** selected from Nailor standard color chart **or** custom color).

Furnish where indicated on plans **and/or** schedules, blank-off panels fabricated by the louver manufacturer. Blank-off panels to be 0.040" (1.02) thick aluminum sheet (**or specifier to select:** 0.040" [1.02] thick aluminum sheet with 1" [25] insulation **or** 0.040" [1.02] thick aluminum sheet with 2" [51] insulation **or** 20 ga. [1.0] galvanized steel **or** 20 ga. [1.0] galvanized steel with 1" [25] insulation **or** 20 ga. [1.0] galvanized steel with 2" [51] insulation). Blank-off panels to be finished to match louvers.

Performance data must be licensed by AMCA under the AMCA Certified Ratings Program and shall bear the AMCA Certified Ratings seal for water penetration and air performance. Free area, water penetration and pressure drop data submitted shall be equal to or better than specified model. Standard of acceptance: Nailor Industries, Inc. Model 1606JD.

- AMCA LICENSED
- WEATHER RESISTANT
- DRAINABLE HEAD
- CONCEALED DOWNSPOUTS
- LOW PRESSURE DROP

Models:

1604KD 4" (102) Deep

1606KD 6" (152) Deep



Model 1604KD



Model 1606KD

Model 1604KD

Model 1604KD combines K style blades with a drainable head that utilizes a top rain gutter with concealed downspouts in the side frame, preventing cascading water running down the building's face from entering into the airstream and infiltrating the space. The blade design features a rear water baffle plus an additional center rain hook, providing additional protection against more forbidding weather. Reinforcing bosses run the full length of each blade for superior strength. Suitable for use in ventilation, exhaust and low to medium velocity intake applications where water penetration is a concern. Available in channel, flanged, or glazing adaptor type, the 4" (102) deep frame installs easily in most common wall configurations. Model 1604KD is AMCA Licensed for Water Penetration and Air Performance.

STANDARD CONSTRUCTION:

- Frame:** 4" (102) deep, Type 6063-T5 extruded aluminum, .080" (2.03) nominal wall thickness. Integral caulking slot provided.
- Blades:** Type 6063-T5 extruded aluminum, .080" (2.03) nominal wall thickness, with reinforcing bosses. K style.
- Blade Angle:** Fixed at 37 degrees.
- Blade Spacing:** Approximately 4" (102) on centers.
- Blade Support Brackets:** Concealed type, factory installed on rear of louver on maximum 60" (1524) centers. Reinforced with 1 1/2" x 2" (38 x 51) angle (adds approx. 2" [51] to overall louver depth).
- Mullions:** Concealed type allowing continuous line appearance up to 120" (3048) wide. Larger assemblies require separate visible frames with downspouts.
- Screen:** 3/4" x .051 (19 x 1.3) expanded, flattened aluminum bird screen in removable frame, inside (rear) mount (adds approximately 3/8" [10] to louver depth).
- Finish:** Mill.
- Minimum Size:** 12" W x 12" H (305 x 305).
- Maximum Single Section Size:** 120" W x 84" H (3048 x 2134) or 84" W x 120" H (2134 x 3048). 70 sq. ft. (6.5 m²). Larger louvers will require field assembly of smaller sections.

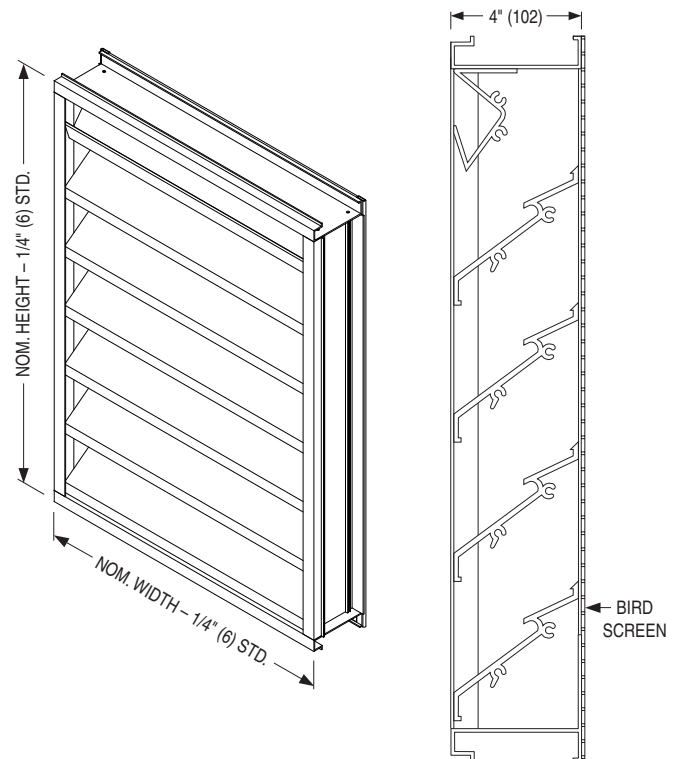

MODEL 1604KD

COMMON OPTIONS:

- Flanged or Glazing Adaptor Frame styles.
- Aluminum or Type 304 Stainless Steel Insect Screens.
- Extended Sills.
- Aluminum Installation Clips or Continuous Angles.
- Variety of Standard and High Performance Powder Coat finishes available in a multitude of colors. Custom color matching available.
- Clear or Color Anodized finishes.



Model 1606D

Model 1606D is designed to provide excellent weather protection in non-wind driven rain conditions with great air performance and pleasing aesthetics that compliment any structure's exterior styling. The drainable head feature is enhanced by the drainable blade design which utilizes additional rain gutters that divert collected water through concealed side downspouts and out the sill, effectively preventing water from infiltrating the space. Blades are reinforced with full length integral bosses for superior strength. Suitable for use in exhaust and low to medium velocity intake applications where water penetration concerns are a priority. Available in channel, flanged, or glazing adaptor type, the 6" (152) deep frame installs easily in most common wall configurations. Model 1606D is AMCA Licensed for Water Penetration and Air Performance.

STANDARD CONSTRUCTION:

- Frame:** 6" (152) deep, Type 6063-T5 extruded aluminum, .080" (2.03) nominal wall thickness. Integral downspouts and caulking slot provided.
- Blades:** Type 6063-T5 extruded aluminum, .080" (2.03) nominal wall thickness, with reinforcing bosses.
- Blade Angle:** Fixed at 37/45 degrees.
- Blade Spacing:** Approximately 5 1/2" (140) on centers.
- Blade Support Brackets:** Concealed type, factory installed on rear of louver on maximum 60" (1524) centers. Reinforced with 1 1/2" x 2" (38 x 51) angle (adds approx. 2" [51] to overall louver depth).
- Mullions:** Concealed type allowing continuous line appearance up to 120" (3048) wide. Larger assemblies require separate visible frames with downspouts.
- Screen:** 3/4" x .051 (19 x 1.3) expanded, flattened aluminum bird screen in removable frame, inside (rear) mount (adds approximately 3/8" [10] to louver depth).
- Finish:** Mill.
- Minimum Size:** 12" W x 12" H (305 x 305).
- Maximum Single Section Size:** 120" W x 84" H (3048 x 2134) or 84" W x 120" H (2134 x 3048). 70 sq. ft. (6.5 m²). Larger louvers will require field assembly of smaller sections.

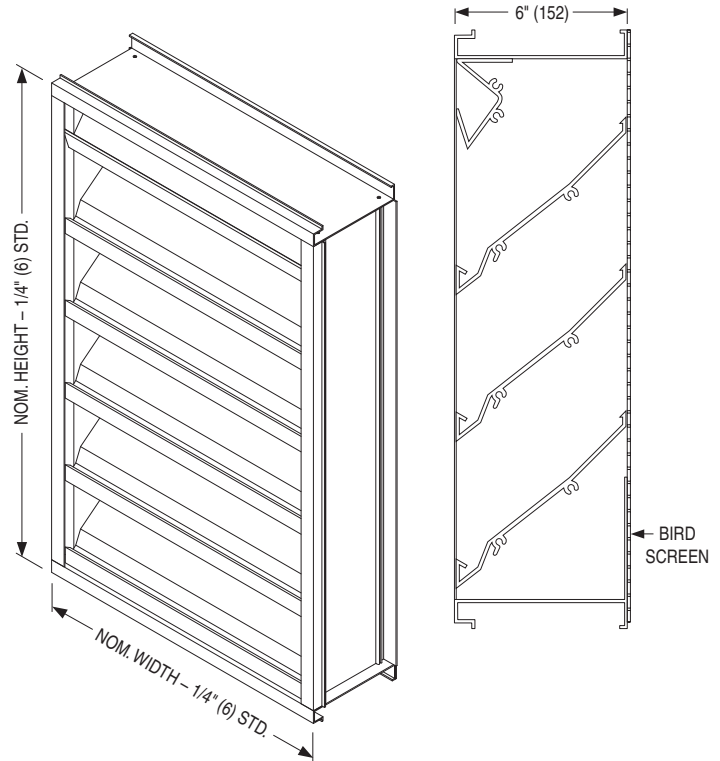

MODEL 1606D

COMMON OPTIONS:

- Flanged or Glazing Adaptor Frame styles.
- Aluminum or Type 304 Stainless Steel Insect Screens.
- Extended Sills.
- Aluminum Installation Clips or Continuous Angles.
- Variety of Standard and High Performance Powder Coat finishes available in a multitude of colors. Custom color matching available.
- Clear or Color Anodized finishes.



PERFORMANCE DATA:

MODEL: 1604D

FREE AREA in Square Feet and Square Meters

LOUVERS

		Width in Inches and Meters																		
		12	18	24	30	36	42	48	54	60	66	72	78	84	90	96	102	108	114	120
Height in Inches and Meters	12	0.30	0.46	0.61	0.76	0.91	1.07	1.22	1.37	1.52	1.68	1.83	1.98	2.13	2.29	2.44	2.59	2.74	2.90	3.05
	0.30	0.31	0.50	0.68	0.87	1.06	1.24	1.43	1.62	1.80	1.99	2.18	2.36	2.55	2.74	2.92	3.11	3.30	3.48	3.67
	0.46	0.54	0.87	1.20	1.52	1.85	2.18	2.50	2.83	3.16	3.48	3.81	4.14	4.47	4.79	5.12	5.45	5.77	6.10	6.43
	0.61	0.78	1.24	1.71	2.18	2.64	3.11	3.58	4.04	4.51	4.98	5.44	5.91	6.38	6.85	7.31	7.78	8.25	8.71	9.18
	0.76	1.06	1.69	2.33	2.97	3.60	4.24	4.87	5.51	6.14	6.78	7.41	8.05	8.69	9.32	9.96	10.59	11.23	11.86	12.50
	0.91	1.29	2.07	2.84	3.62	4.39	5.17	5.95	6.72	7.50	8.27	9.05	9.82	10.60	11.37	12.15	12.93	13.70	14.48	15.25
	1.07	1.57	2.52	3.46	4.41	5.35	6.30	7.24	8.18	9.13	10.07	11.02	11.96	12.91	13.85	14.79	15.74	16.68	17.63	18.57
	1.22	1.81	2.89	3.98	5.06	6.14	7.23	8.26	9.40	10.48	11.57	12.65	13.74	14.82	15.90	16.99	18.07	19.16	20.24	21.33
	1.37	2.04	3.27	4.49	5.71	6.94	8.16	9.39	10.61	11.84	13.06	14.28	15.51	16.73	17.96	19.18	20.41	21.63	22.86	24.08
	1.52	2.32	3.72	5.11	6.50	7.89	9.29	10.68	12.07	13.47	14.86	16.25	17.65	19.04	20.43	21.83	23.22	24.61	26.01	27.40
	1.68	2.56	4.09	5.62	7.15	8.69	10.22	11.75	13.29	14.82	16.35	17.89	19.42	20.95	22.49	24.02	25.55	27.09	28.62	30.15
	1.83	2.84	4.54	6.24	7.94	9.64	11.35	13.05	14.75	16.45	18.15	19.86	21.56	23.26	24.96	26.66	28.37	30.07	31.77	33.47
	1.98	3.07	4.91	6.75	8.60	10.44	12.28	14.12	15.96	17.81	19.65	21.49	23.33	25.17	27.02	28.86	30.70	32.54	34.38	36.23
	2.13	3.30	5.29	7.27	9.25	11.23	13.21	15.20	17.18	19.16	21.14	23.12	25.11	27.09	29.07	31.05	33.03	35.02	37.00	38.98
	2.29	3.58	5.74	7.89	10.04	12.19	14.34	16.49	18.64	20.79	22.94	25.09	27.24	29.39	31.55	33.70	35.85	38.00	40.15	42.30
	2.44	3.82	6.11	8.40	10.69	12.98	15.27	17.56	19.85	22.15	24.44	26.73	29.02	31.31	33.60	35.89	38.18	40.47	42.76	45.05
	2.59	4.10	6.56	9.02	11.48	13.94	16.40	18.86	21.32	23.78	26.24	28.70	31.16	33.62	36.08	38.53	40.99	43.45	45.91	48.37
	2.74	4.33	6.93	9.53	12.13	14.73	17.33	19.93	22.53	25.13	27.73	30.33	32.93	35.53	38.13	40.73	43.33	45.93	48.53	51.13
	2.90	4.57	7.31	10.05	12.79	15.53	18.26	21.00	23.74	26.48	29.22	31.96	34.70	37.44	40.18	42.92	45.66	48.40	51.14	53.88
	3.05	4.85	7.76	10.66	13.57	16.48	19.39	22.30	25.21	28.12	31.02	33.93	36.84	39.75	42.66	45.57	48.48	51.38	54.29	57.20

AIRFLOW/ WATER PENETRATION DATA

for 48" x 48" (1219 x 1219) Louver Size

Model	1604D	
Free Area %	52%	
Free Area sq. ft. (sq. m.)	8.26 (0.77)	
INTAKE	Free Area Velocity at Point of Beginning Water Penetration at .01 oz./sq. ft. (3 ml/sq. m) (15 min. test duration)	906 fpm (272 m/min.)
	Air Volume at Free Area Velocity shown	7484 cfm (3532 l/s)
	Pressure Drop at Free Area Velocity shown	.15 in. w.g. (37 Pa)

NOTE: To minimize water penetration when sizing intake louvers, select a Free Area Velocity that is **below** the point of beginning water penetration.

PRESSURE DROP

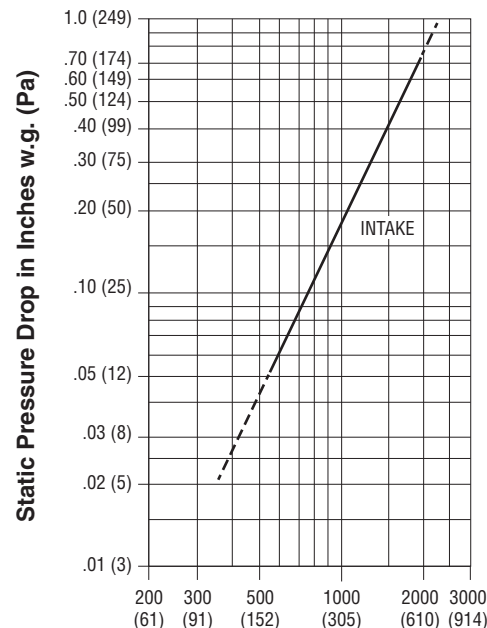

Air Velocity in Feet (Meters) Per Minute through Free Area
 Louver test size: 48" x 48" (1219 x 1219 mm).
 Standard air density @ 0.075 lbs/ft³.
 Tested to AMCA Fig. 5.5 – 6.5.



Nailor Industries Inc. certifies the Model 1604D, shown herein is licensed to bear the AMCA Seal. The ratings shown are based on tests and procedures performed in accordance with AMCA Publication 511 and comply with the requirements of the AMCA Certified Ratings Program. The AMCA Certified Ratings Seal applies to Air Performance and Water Penetration ratings.

PERFORMANCE DATA:

MODEL: 1606D

FREE AREA in Square Feet and Square Meters

		Width in Inches and Meters																		
		12	18	24	30	36	42	48	54	60	66	72	78	84	90	96	102	108	114	120
Height in Inches and Meters	12	0.24	0.39	0.54	0.70	0.85	1.00	1.15	1.30	1.45	1.60	1.75	1.90	2.05	2.20	2.36	2.51	2.66	2.81	2.96
	18	0.41	0.67	0.93	1.19	1.45	1.70	1.96	2.22	2.48	2.74	2.99	3.25	3.51	3.77	4.03	4.28	4.54	4.80	5.06
	24	0.68	1.10	1.53	1.95	2.38	2.80	3.23	3.65	4.07	4.50	4.92	5.35	5.77	6.20	6.62	7.04	7.47	7.89	8.32
	30	0.93	1.51	2.09	2.67	3.25	3.83	4.40	4.98	5.56	6.14	6.72	7.30	7.88	8.46	9.04	9.62	10.20	10.78	11.35
	36	1.09	1.77	2.45	3.13	3.81	4.49	5.17	5.85	6.53	7.21	7.89	8.58	9.26	9.94	10.62	11.30	11.98	12.66	13.34
	42	1.44	2.34	3.23	4.13	5.03	5.92	6.82	7.72	8.61	9.51	10.41	11.30	12.20	13.10	13.99	14.89	15.79	16.68	17.58
	48	1.69	2.74	3.79	4.84	5.89	6.94	7.99	9.05	10.10	11.15	12.20	13.25	14.30	15.35	16.40	17.46	18.51	19.56	20.61
	54	1.94	3.15	4.36	5.57	6.78	7.99	9.20	10.41	11.62	12.83	14.04	15.25	16.46	17.67	18.88	20.09	21.30	22.51	23.72
	60	2.19	3.56	4.93	6.30	7.67	9.04	10.40	11.77	13.14	14.51	15.88	17.24	18.61	19.98	21.35	22.72	24.08	25.45	26.82
	66	2.45	3.98	5.50	7.03	8.55	10.08	11.61	13.13	14.66	16.19	17.71	19.24	20.77	22.29	23.82	25.34	26.87	28.40	29.92
	72	2.70	4.39	6.07	7.76	9.45	11.13	12.82	14.50	16.19	17.87	19.56	21.24	22.93	24.61	26.30	27.98	29.67	31.36	33.04
	78	2.96	4.80	6.65	8.49	10.33	12.18	14.02	15.86	17.71	19.55	21.40	23.24	25.08	26.93	28.77	30.61	32.46	34.30	36.14
	84	3.21	5.22	7.22	9.22	11.22	13.23	15.23	17.23	19.23	21.24	23.24	25.24	27.24	29.25	31.25	33.25	35.25	37.26	39.26
	90	3.47	5.63	7.79	9.95	12.11	14.27	16.44	18.60	20.76	22.96	25.08	27.24	29.40	31.57	33.73	35.89	38.05	40.21	42.37
	96	3.72	6.04	8.36	10.68	13.00	15.32	17.64	19.96	22.29	24.61	26.93	29.25	31.57	33.89	36.21	38.53	40.85	43.17	45.49
	102	3.98	6.46	8.94	11.41	13.89	16.37	18.85	21.33	23.81	26.29	28.77	31.25	33.73	36.20	38.68	41.16	43.64	46.12	48.60
108	4.23	6.87	9.51	12.15	14.78	17.42	20.06	22.70	25.33	27.97	30.61	33.25	35.89	38.52	41.16	43.80	46.44	49.08	51.71	
114	4.51	7.31	10.12	12.93	15.74	18.55	21.36	24.16	26.97	29.78	32.59	35.40	38.21	41.02	43.82	46.63	49.44	52.25	55.06	
120	4.74	7.70	10.66	13.61	16.57	19.52	22.48	25.44	28.39	31.35	34.31	37.26	40.22	43.17	46.13	49.09	52.04	55.00	57.96	

AIRFLOW/WATER PENETRATION DATA

for 48" x 48" (1219 x 1219) Louver Size

Model		1606D
Free Area %		50%
Free Area sq. ft. (sq. m.)		7.99 (0.74)
I N T A K E	Free Area Velocity at Point of Beginning Water Penetration at .01 oz./sq. ft. (3 ml/sq. m) (15 min. test duration)	1195 fpm (364 m/min.)
	Air Volume at Free Area Velocity shown	9452 cfm (4460 l/s)
	Pressure Drop at Free Area Velocity shown	.18 in. w.g. (45 Pa)

NOTE: To minimize water penetration when sizing intake louvers, select a Free Area Velocity that is **below** the point of beginning water penetration.

PRESSURE DROP

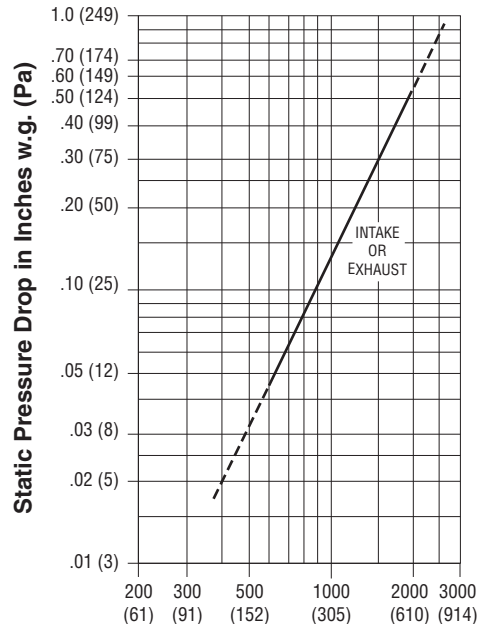

Air Velocity in Feet (Meters) Per Minute Through Free Area

Louver test size: 48" x 48" (1219 x 1219 mm).

Standard air density @ 0.075 lbs/ft³.

Tested to AMCA Fig. 5.5 - 6.5.



Nailor Industries Inc. certifies the Model 1606D, shown herein is licensed to bear the AMCA Seal. The ratings shown are based on tests and procedures performed in accordance with AMCA Publication 511 and comply with the requirements of the AMCA Certified Ratings Program. The AMCA Certified Ratings Seal applies to Air Performance and Water Penetration ratings.

HOW TO SPECIFY

MODEL 1604D

EXTRUDED ALUMINUM DRAINABLE BLADE LOUVERS

SUGGESTED SPECIFICATION:

Provide and install, as shown on plans and/or schedules, extruded aluminum louvers meeting or exceeding the following criteria: Frame shall be 4" (102) deep channel type (**or specifier to select:** flanged type **or** glazing adapter type), 1/4" (6.3) undersize (**or specifier to select:** exact size **or** 3/8" [9.5] undersize **or** 1/2" [12.7] undersize), with integral caulking slots (and **specifier to select, if required:** extended sill), constructed from ASTM B211 Alloy 6063-T5 extruded aluminum of .080" (2.03) nominal wall thickness. Blades shall be stationary drainable style, with drain gutter in each blade and gutter in head frame, constructed from type 6063-T5 extruded aluminum of .080" (2.03) nominal wall thickness with reinforcing bosses, fixed at 37 degrees on approximately 4" (102) centers and shall be supported by angle reinforced concealed brackets as required to withstand a wind force of not less than 25 pounds per square foot (100 miles per hour). Concealed downspouts in jambs to drain water from louver for minimum water cascade from blade to blade. Factory assembled louver components to be mechanically fastened (**or specifier to select:** welded construction). Concealed type mullions for louvers up to 120" (3048) wide allowing continuous line appearance. Large louvers that require multiple sections for shipping shall be constructed with visible frames with downspouts when installed together on site. Louvers shall be equipped with removable 3/4" x .051 (19 x 1.3) expanded, flattened aluminum bird screen (**or specifier to select:** type 304 stainless steel bird screen **and/or** aluminum insect screen **and/or** type 304 stainless steel insect screen **or** no screen).

Finish shall be standard mill (**or specifier to select:** prime coat **or** 204-R1 clear anodized to a min. depth of 0.4 mil, with 1 year warranty **or** 215-R1 clear anodized to a min. depth of 0.7 mil, with 5 year warranty **or** color anodized; color to be selected from standard Nailor anodizing colors **or** AAMA 2603 thermosetting polyester powder coat, with 1 year warranty; color to be (**specifier to select:** selected from Nailor standard color chart **or** custom color) **or** AAMA 2604 high performance polyester powder coat, with 5 year warranty; color to be (**specifier to select:** selected from Nailor standard color chart **or** custom color) **or** AAMA 2605 FEVE fluoropolymer powder coat, with 10 year warranty; color to be (**specifier to select:** selected from Nailor standard color chart **or** custom color) **or** Kynar 500/Hylar 5000 70% PVDF coating, with 5 year warranty; color to be (**specifier to select:** selected from Nailor standard color chart **or** custom color) **or** Kynar 500/Hylar 5000 50% PVDF coating, with 10 year warranty; color to be (**specifier to select:** selected from Nailor standard color chart **or** custom color).

Furnish where indicated on plans and/or schedules, blank-off panels fabricated by the louver manufacturer. Blank-off panels to be 0.040" (1.02) thick aluminum sheet (**or specifier to select:** 0.040" [1.02] thick aluminum sheet with 1" [25] insulation **or** 0.040" [1.02] thick aluminum sheet with 2" [51] insulation **or** 20 ga. [1.0] galvanized steel **or** 20 ga. [1.0] galvanized steel with 1" [25] insulation **or** 20 ga. [1.0] galvanized steel with 2" [51] insulation). Blank-off panels to be finished to match louvers.

Performance data must be licensed by AMCA under the AMCA 511 Certified Ratings Program and shall bear the AMCA Certified Ratings seal for water penetration and air performance. Free area, water penetration and pressure drop data submitted shall be equal to or better than specified model. Standard of acceptance: Nailor Industries, Inc. Model 1604D.

MODEL 1606D

EXTRUDED ALUMINUM DRAINABLE BLADE LOUVERS

SUGGESTED SPECIFICATION:

Provide and install, as shown on plans and/or schedules, extruded aluminum louvers meeting or exceeding the following criteria: Frame shall be 6" (152) deep channel type (**or specifier to select:** flanged type **or** glazing adapter type), 1/4" (6.3) undersize (**or specifier to select:** exact size **or** 3/8" [9.5] undersize **or** 1/2" [12.7] undersize), with integral caulking slots (and **specifier to select, if required:** extended sill), constructed from ASTM B211 Alloy 6063-T5 extruded aluminum of .080" (2.03) nominal wall thickness. Blades shall be stationary drainable style, with drain gutter in each blade and gutter in head frame. Concealed downspouts in jambs to drain water from louver for minimum water cascade from blade to blade. Constructed from type 6063-T5 extruded aluminum of .080" (2.03) nominal wall thickness, fixed at 37/45 degrees on approximately 5 1/2" (140) centers and shall be supported by angle reinforced concealed brackets as required to withstand a wind force of not less than 25 pounds per square foot (100 miles per hour). Factory assembled louver components to be mechanically fastened (**or specifier to select:** welded construction). Concealed type mullions for louvers up to 120" (3048) wide allowing continuous line appearance. Large louvers that require multiple sections for shipping shall be constructed with visible frames with downspouts when installed together on site. Louvers shall be equipped with removable 3/4" x .051 (19 x 1.3) expanded, flattened aluminum bird screen (**or specifier to select:** type 304 stainless steel bird screen **and/or** aluminum insect screen **and/or** type 304 stainless steel insect screen **or** no screen).

Finish shall be standard mill (**or specifier to select:** prime coat **or** 204-R1 clear anodized to a min. depth of 0.4 mil, with 1 year warranty **or** 215-R1 clear anodized to a min. depth of 0.7 mil, with 5 year warranty **or** color anodized; color to be selected from standard Nailor anodizing colors **or** AAMA 2603 thermosetting polyester powder coat, with 1 year warranty; color to be (**specifier to select:** selected from Nailor standard color chart **or** custom color) **or** AAMA 2604 high performance polyester powder coat, with 5 year warranty; color to be (**specifier to select:** selected from Nailor standard color chart **or** custom color) **or** AAMA 2605 FEVE fluoropolymer powder coat, with 10 year warranty; color to be (**specifier to select:** selected from Nailor standard color chart **or** custom color) **or** Kynar 500/Hylar 5000 70% PVDF coating, with 5 year warranty; color to be (**specifier to select:** selected from Nailor standard color chart **or** custom color) **or** Kynar 500/Hylar 5000 50% PVDF coating, with 10 year warranty; color to be (**specifier to select:** selected from Nailor standard color chart **or** custom color).

Furnish where indicated on plans and/or schedules, blank-off panels fabricated by the louver manufacturer. Blank-off panels to be 0.040" (1.02) thick aluminum sheet (**or specifier to select:** 0.040" [1.02] thick aluminum sheet with 1" [25] insulation **or** 0.040" [1.02] thick aluminum sheet with 2" [51] insulation **or** 20 ga. [1.0] galvanized steel **or** 20 ga. [1.0] galvanized steel with 1" [25] insulation **or** 20 ga. [1.0] galvanized steel with 2" [51] insulation). Blank-off panels to be finished to match louvers.

Performance data must be licensed by AMCA under the AMCA 511 Certified Ratings Program and shall bear the AMCA Certified Ratings seal for water penetration and air performance. Free area, water penetration and pressure drop data submitted shall be equal to or better than specified model. Standard of acceptance: Nailor Industries, Inc. Model 1606D.

- AMCA LICENSED
- DUAL DRAINABLE BLADE
- DRAINABLE HEAD
- PROTECTS AGAINST HEAVY RAIN
- SUPERIOR PERFORMANCE

Models:

- 1604DD 4" (102) Deep
- 1606DD 6" (152) Deep



Model 1604DD

Model 1606DD

Model 1604DD

Model's 1604DD combines exceptional weather protection during the most enduring non-wind driven rain conditions, great air performance through a large free area and pleasing aesthetics that enhance any structure's exterior design. Complemented by a drainable head, the dual drainable blade design utilizes double rain gutters that divert collected water down concealed side downspouts and out through the sill, preventing water from infiltrating the space. Blades are reinforced with full length integral bosses for superior strength. Suitable for use in exhaust and medium to high velocity intake applications where water penetration concerns are a top priority. Available in channel, flanged, or glazing adaptor type, the 4" (102) deep frame installs easily in most common wall configurations. Model 1604DD is AMCA Licensed for Water Penetration and Air Performance.

STANDARD CONSTRUCTION:

- Frame:** 4" (102) deep, Type 6063-T5 extruded aluminum, .080" (2.03) nominal wall thickness. Integral downspouts and caulking slot provided.
- Blades:** Type 6063-T5 extruded aluminum, .080" (2.03) nominal wall thickness, with reinforcing bosses.
- Blade Angle:** Fixed at 37 degrees.
- Blade Spacing:** Approximately 4" (102) on centers.
- Blade Support Brackets:** Concealed type, factory installed on rear of louver on maximum 60" (1524) centers. Reinforced with 1 1/2" x 2" (38 x 51) angle (adds approx. 2" [51] to overall louver depth).
- Mullions:** Concealed type allowing continuous line appearance up to 120" (3048) wide. Larger assemblies require separate visible frames with downspouts.
- Screen:** 3/4" x .051 (19 x 1.3) expanded, flattened aluminum bird screen in removable frame, inside (rear) mount (adds approximately 3/8" [10] to louver depth).
- Finish:** Mill.
- Minimum Size:** 12" W x 12" H (305 x 305).
- Maximum Single Section Size:** 120" W x 84" H (3048 x 2134) or 84" W x 120" H (2134 x 3048). 70 sq. ft. (6.5 m²). Larger louvers will require field assembly of smaller sections.

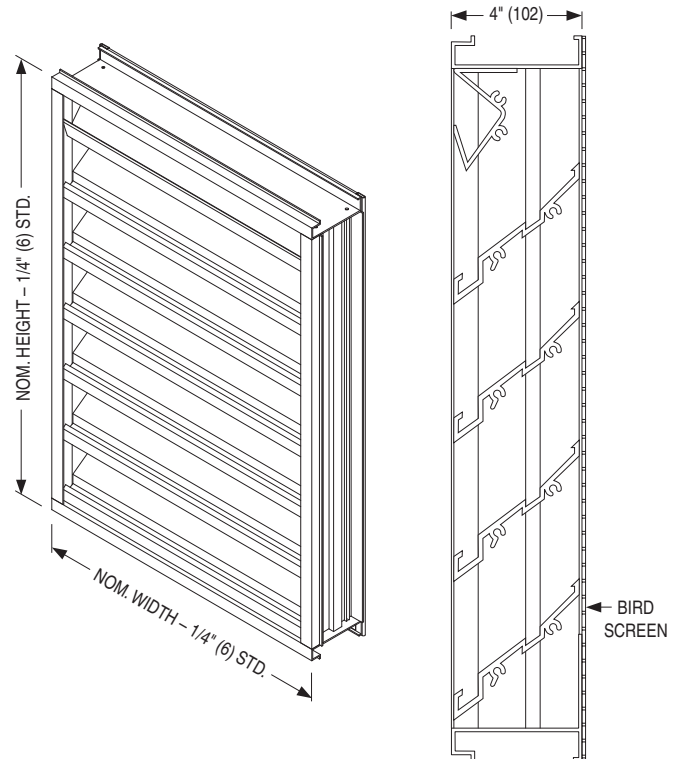

MODEL 1604DD

COMMON OPTIONS:

- Flanged or Glazing Adaptor Frame styles.
- Aluminum or Type 304 Stainless Steel Insect Screens.
- Extended Sills.
- Aluminum Installation Clips or Continuous Angles.
- Variety of Standard and High Performance Powder Coat finishes available in a multitude of colors. Custom color matching available.
- Clear or Color Anodized finishes.



Model 1606DD

Model 1606DD combines exceptional weather protection during the most enduring non-wind driven rain conditions, great air performance through a large free area and a clean look that will enhance the exterior of any structure. Complemented by a drainable head, the dual drainable blade design features double rain gutters that divert cascading water running down the building's face down concealed side downspouts and out through the sill, preventing water from infiltrating the space. Blades are reinforced with full length integral bosses for superior strength. Suitable for use in exhaust and medium to high velocity intake applications where water penetration concerns are a top priority. Available in channel, flanged, or glazing adapter type, the 6" (152) deep frame installs easily in most common wall configurations. Model 1606DD is AMCA Licensed for Water Penetration and Air Performance.

STANDARD CONSTRUCTION:

- Frame:** 6" (152) deep, Type 6063-T5 extruded aluminum, .080" (2.03) nominal wall thickness. Integral downspouts and caulking slot provided.
- Blades:** Type 6063-T5 extruded aluminum, .080" (2.03) nominal wall thickness, with reinforcing bosses.
- Blade Angle:** Fixed at 37 degrees.
- Blade Spacing:** Approximately 6" (152) on centers.
- Blade Support Brackets:** Concealed type, factory installed on rear of louver on maximum 60" (1524) centers. Reinforced with 1 1/2" x 2" (38 x 51) angle (adds approx. 2" [51] to overall louver depth).
- Mullions:** Concealed type allowing continuous line appearance up to 120" (3048) wide. Larger assemblies require separate visible frames with downspouts.
- Screen:** 3/4" x .051 (19 x 1.3) expanded, flattened aluminum bird screen in removable frame, inside (rear) mount (adds approximately 3/8" [10] to louver depth).
- Finish:** Mill.
- Minimum Size:** 12" W x 12" H (305 x 305).
- Maximum Single Section Size:** 120" W x 84" H (3048 x 2134) or 84" W x 120" H (2134 x 3048). 70 sq. ft. (6.5 m²). Larger louvers will require field assembly of smaller sections.

COMMON OPTIONS:

- Flanged or Glazing Adaptor Frame styles.
- Aluminum or Type 304 Stainless Steel Insect Screens.
- Extended Sills.
- Aluminum Installation Clips or Continuous Angles.
- Variety of Standard and High Performance Powder Coat finishes available in a multitude of colors. Custom color matching available.
- Clear or Color Anodized finishes.

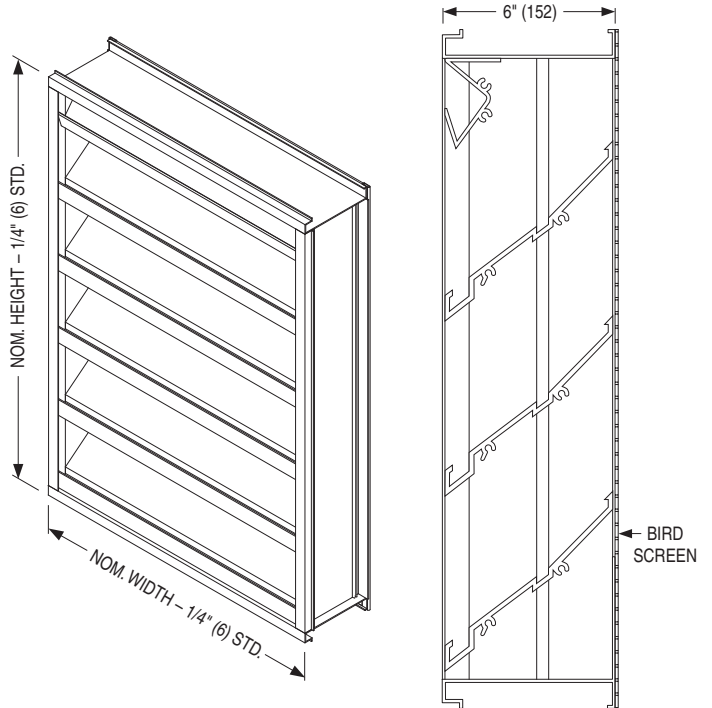

MODEL 1606DD



