

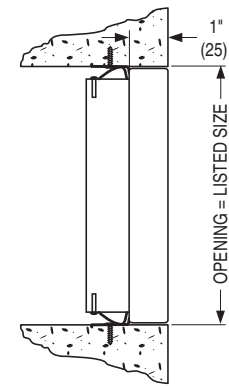

**RECTANGULAR 1-WAY DISPLACEMENT DIFFUSER  
RISER/RECESSED WALL MOUNT • FLAT FACE  
STEEL PERFORATED FACE  
MODEL: DWR1**

**Model DWR1 • 1-Way Discharge Air Pattern**

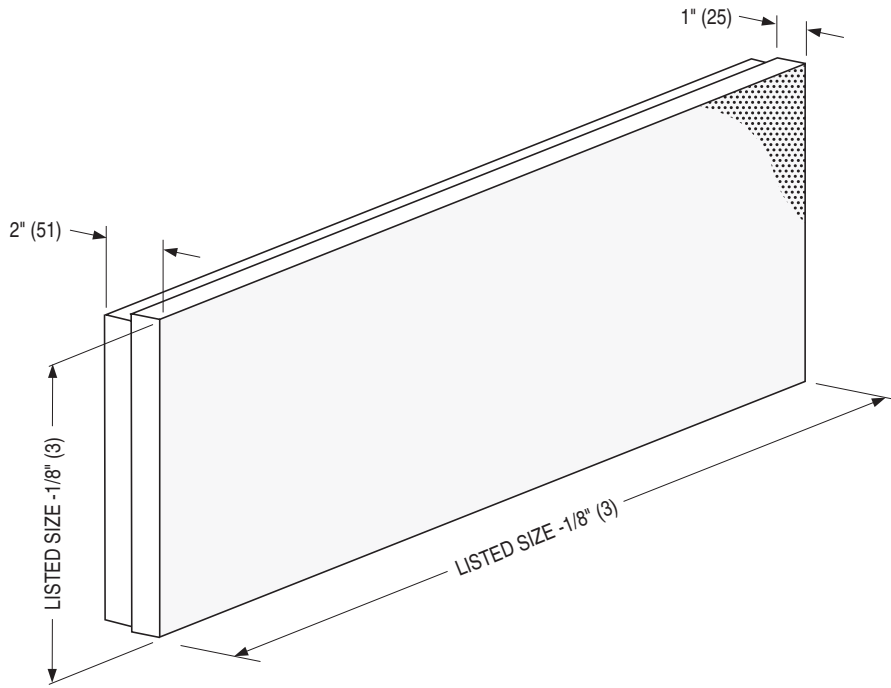

**RECESSED MOUNT DETAIL**

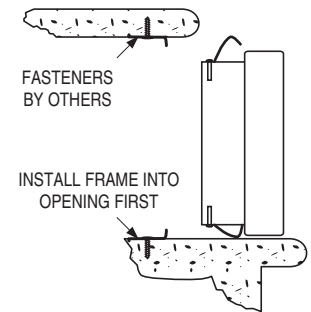

**RISER MOUNT DETAIL**

**DESCRIPTION:**

1. Construction: Heavy gauge corrosion-resistant coated steel. Standard 18 ga. (1.3) perforated face plate has 3/32" (2) dia. holes on 3/16" (5) staggered centers, providing 23% free area.
2. An equalization baffle is provided behind the diffuser face to ensure an even distribution of low velocity supply air.
3. Riser/Recessed in-wall mounted displacement diffusers are especially designed to supply air at a very low velocity to minimize the potential for drafts and enhance occupant comfort.
4. Minimum size is 6" x 4" (152 x 102).  
Maximum size is 60" x 36" (1524 x 914).  
Available in intermediate sizes in 2" (102) increments.
5. Diffuser is supplied with mounting frame for spring clip mounting into wall or riser opening.
6. Standard finish is AW Appliance White.

**OPTIONS:**

1. Construction:
  - 16GP Heavy Duty 16 ga. (1.6) Perforated Face
2. Inlet Type:
  - REC Rectangular
3. Finish:
  - AW Appliance White (default)
  - AL Aluminum
  - BK Black
  - BW British White
  - SP Special \_\_\_\_\_
4. Protective Film:
  - PFC Protective Film Cover on Face and Inlet
5. Plaster Frame:
  - PMF Plaster/Mud Frame

<b>SCHEDULE TYPE:</b>		Dimensions are in inches (mm).			
<b>PROJECT:</b>					
<b>ENGINEER:</b>	<b>DATE</b>	<b>B SERIES</b>	<b>SUPERSEDES</b>	<b>DRAWING NO.</b>	
<b>CONTRACTOR:</b>	2 - 25 - 20	DW	1 - 8 - 20	DWR1	